



## Electric Chainsaw Sharpener

Bench or Wall Mount

Owner's Manual



**⚠ WARNING:** Read carefully and understand all ASSEMBLY AND OPERATION INSTRUCTIONS before operating. Failure to follow the safety rules and other basic safety precautions may result in serious personal injury.

Item #57523

**READ & SAVE THESE INSTRUCTIONS**

Thank you very much for choosing a Strongway™ product!

For future reference, please complete the owner's record below:

Serial Number/Lot Date Code: \_\_\_\_\_

Purchase Date: \_\_\_\_\_

Save the receipt, warranty, and this manual. It is important that you read the entire manual to become familiar with this product before you begin using it.

This sharpener is designed for certain applications only. Northern Tool and Equipment is not responsible for issues arising from modification or improper use of this product such as an application for which it was not designed. We strongly recommend that this product not be modified and/or used for any application other than that for which it was designed.

For technical questions, please call **1-800-222-5381**.

## Table of Contents

Intended Use.....	4
Technical Specifications .....	4
Important Safety Information .....	4
Specific Operation Warnings .....	6
Grounding .....	6
Extension Cords.....	7
Main Parts of Sharpener .....	8
Assembly Instructions.....	8
Before Each Use.....	10
Operating Instructions.....	10
After Each Use.....	12
Maintenance .....	12
Troubleshooting .....	13
Parts Diagram .....	14
Parts List .....	14
Replacement Parts .....	15
Limited Warranty .....	16

## Intended Use

The Strongway Electric Chainsaw Sharpener with Bench or Wall Mount is designed for sharpening most chainsaws.

## Technical Specifications

Property	Specification
Supply voltage	110 Volt / 60Hz
Chain Pitch	¼ Inch to ¾ Inch
Motor input power	2.1 Amps (230 W)
Maximum speed	3400 RPM
Weight	20 lb.

## Important Safety Information

### **⚠WARNING**

- Read and understand all instructions. Failure to follow all instructions may result in serious injury or property damage.
- The warnings, cautions, and instructions in this manual cannot cover all possible conditions or situations that could occur. Exercise common sense and caution when using this tool. Always be aware of the environment and ensure that the tool is used in a safe and responsible manner.
- Do not allow persons to operate or assemble the product until they have read this manual and have developed a thorough understanding of how it works.
- Do not modify this product in any way. Unauthorized modification may impair the function and/or safety and could affect the life of the product. There are specific applications for which the product was designed.
- Use the right tool for the job. DO NOT attempt to force small equipment to do the work of larger industrial equipment. There are certain applications for which this equipment was designed. This product will be safer and do a better job at the capacity for which it was intended. DO NOT use this equipment for a purpose for which it was not intended.
- Industrial or commercial applications must follow OSHA requirements.

### **⚠WARNING**

#### **WORK AREA SAFETY**

- Inspect the work area before each use. Keep work area clean, dry, free of clutter, and well-lit. Cluttered, wet, or dark work areas can result in injury. Using the product in confined work areas may put you dangerously close to cutting tools and rotating parts.
- Do not use the product where there is a risk of causing a fire or an explosion; e.g., in the presence of flammable liquids, gases, or dust. The product can create sparks, which may ignite the flammable liquids, gases, or dust.
- Do not allow the product to come into contact with an electrical source. The tool is not insulated

and contact will cause electrical shock.

- Keep children and bystanders away from the work area while operating the tool. Do not allow children to handle the product.

## **⚠WARNING**

### **PERSONAL SAFETY**

- Stay alert, watch what you are doing, and use common sense when operating the tool. Do not use the tool while you are tired or under the influence of drugs, alcohol, or medication. A moment of inattention while operating the tool may result in serious personal injury.
- Dress properly. Do not wear loose clothing, dangling objects, or jewelry. Keep your hair, clothing and gloves away from moving parts. Loose clothes, jewelry, or long hair can be caught in moving parts. Air vents on the tool often cover moving parts and should be avoided.
- Wear the proper personal protective equipment when necessary. Use ANSI Z87.1 compliant safety goggles (not safety glasses) with side shields, or when needed, a face shield. Use a dust mask in dusty work conditions. Also use non-skid safety shoes, hardhat, gloves, dust collection systems, and hearing protection when appropriate. This applies to all persons in the work area.
- Do not overreach. Keep proper footing and balance at all times.
- Remove keys or wrenches before connecting the tool to an air supply, power supply, or turning on the tool. A wrench or key that is left attached to a rotating part of the tool may cause personal injury.
- Secure the work with clamps or a vise instead of your hand when practical. This safety precaution allows for proper tool operation using both hands.

## **⚠CAUTION**

### **SHARPENER USE AND CARE**

- Do not force the sharpener. Products are safer and do a better job when used in the manner for which they are designed. Plan your work, and use the correct product for the job.
- Check for damaged parts before each use. Carefully check that the product will operate properly and perform its intended function. Replace damaged or worn parts immediately. Never operate the product with a damaged part.
- Do not use a product with a malfunctioning switch. Any power tool that cannot be controlled with the power switch is dangerous and must be repaired by an authorized service representative before using.
- Disconnect the power/air supply from the product and place the switch in the locked or off position before making any adjustments, changing accessories, or storing the tool. Such preventive safety measures reduce the risk of starting the tool accidentally.
- Store the sharpener when it is not in use. Store it in a dry, secure place out of the reach of children. Inspect the tool for good working condition prior to storage and before re-use.
- Use only accessories that are recommended by the manufacturer for use with your product. Accessories that may be suitable for one product may create a risk of injury when used with

another tool. Never use an accessory that has a lower operating speed or operating pressure than the tool itself.

- Keep guards in place and in working order. Never operate the product without the guards in place.
- Do not leave the tool running unattended.

## Specific Operation Warnings

### **⚠WARNING**

- Wear the proper protective equipment including ANSI Z87.1 compliant eye protection, NIOSH compliant breathing protection, and hearing protection.
- Do not use grinding wheels that have a max RPM less than the marked RPM rating on the tool.
- Keep hands clear from grinding wheel during use.
- Electric shock hazard. Do not expose to rain or use in damp locations.
- Do not use for wet grinding.
- Do not use wheel if cracked or chipped.
- Disconnect tools before servicing; when changing accessories, such as blades, bits, cutters, and the like.
- Reduce the risk of unintentional starting. Make sure switch is in off position before plugging in.
- Direction of feed. Feed work into a blade or cutter against the direction of rotation of the blade or cutter only.
- When using the sharpener outdoors, always use an outdoor rated extension cord with a splash-proof plug and socket.
- Do not use a caustic solution to clean plastic parts.
- Do not use the sharpener in the proximity of flammable liquids and vapors.
- Not for use by or around children.

## Grounding

### **⚠WARNING**

- This sharpener must be grounded while in use to protect the operator from electrical shock. This unit is equipped with an electrical cord that has an equipment grounding conductor and a grounding plug. The plug **MUST** be plugged into a matching receptacle that is properly installed and grounded in accordance with ALL local codes and ordinances.
- **DO NOT MODIFY THE PROVIDED PLUG.** If it will not fit the receptacle, have the proper receptacle installed by a qualified electrician.
- **CHECK** with a qualified electrician or service person if you do not completely understand the grounding instructions, or if you are not sure the tool is properly grounded.

### **Grounded Tools: Tools with 3-Prong Plugs**

Tools marked with **Grounding Required** have a 3-wire cord and 3-prong grounding plug. The plug must be connected to a properly grounded outlet. If the tool should electrically malfunction or break down, grounding provides a low resistance path to carry electricity away from the user, reducing the risk of electric shock. (See Figure A.)

The grounding prong in the plug is connected through the green wire inside the cord to the grounding system in the tool. The green wire in the cord must be the only wire connected to the tool's grounding system and must never be attached to an electrically live terminal.

Your tool must be plugged into an appropriate outlet, properly installed and grounded in accordance with all codes and ordinances. The plug and outlet should look like those in the following illustration.

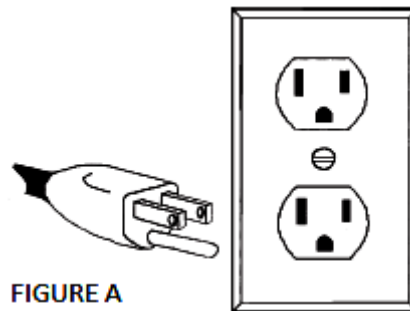

### Double Insulated Tools: Tools with Two-Prong Plugs

Tools marked **Double Insulated** do not require grounding. They have a special double insulation system which satisfies OSHA requirements and complies with the applicable standards of Underwriters Laboratories, Inc., the Canadian Standard Association, and the National Electrical Code. (See Figure B.)

Double insulated tools may be used in either of the 120 volt outlets shown in the following illustration.

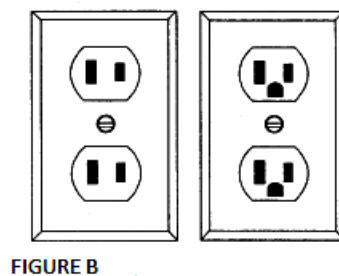

## Extension Cords

### ⚠ WARNING

- **USE A PROPER EXTENSION CORD.** Make sure your extension cord is in good condition. When using an extension cord, be sure to use one heavy enough to carry the current your product will draw. An undersized cord will cause a drop in line voltage, resulting in loss of power and cause overheating.
- Be sure your extension cord is properly wired and in good condition. Always replace a damaged extension cord or have it repaired by a qualified person before using it. Protect your extension cords from sharp objects, excessive heat and damp or wet areas.
- Grounded tools require a 3-wire extension cord. Double Insulated tools can use either a 2- or 3-wire extension cord.

- As the distance from the supply outlet increases, you must use a heavier gauge extension cord. Using extension cords with inadequately sized wire causes a serious drop in voltage, resulting in loss of power and possible tool damage.
- The smaller the wire gauge number, the greater the capacity of the cord. For example, a 14-gauge cord can carry a higher current than a 16-gauge cord. Minimum extension cord wire size is shown in the following table:

<b>Minimum Wire Size Of Extension Cords</b>				
<b>Nameplate AMPS</b>	<b>Cord Length</b>			
	<b>25'</b>	<b>50'</b>	<b>100'</b>	<b>150'</b>
0-6	18 AWG	16 AWG	16 AWG	14 AWG
6-10	18 AWG	16 AWG	14 AWG	12 AWG
10-12	16 AWG	16 AWG	14 AWG	12 AWG
12-16	14 AWG	12 AWG	NOT RECOMMENDED	

- When using more than one extension cord to make up the total length, make sure each cord contains at least the minimum wire size required.
- If you are using one extension cord for more than one tool, add the nameplate amperes and use the sum to determine the required minimum cord size.
- If you are using an extension cord outdoors, make sure it is marked with the suffix **W-A** (**W** in Canada) to indicate it is acceptable for outdoor use.
- Make sure your extension cord is properly wired and in good electrical condition. Always replace a damaged extension cord or have it repaired by a qualified electrician before using it.
- Protect your extension cords from sharp objects, excessive heat, and damp or wet areas.

### Main Parts of Sharpener

<b>Reference</b>	<b>Subassembly</b>
1	Body
2	Base
3	Handle
4	Grinding Disc

### Assembly Instructions

**⚠WARNING**

- Assembly must be performed with the sharpener unplugged!
- Always unplug the sharpener before doing any work on it (cleaning, disc replacement, etc.)
- Install sharpener with some distance from the wall (use spacers) in order to retain access to the rear set screw.
- When mounting on the wall, take care to mount the sharpener at a height of about 50 inches to avoid working at eye level.

The sharpener is delivered partly assembled. One part consists of the base on which the chain guide is located. The other part is a bearing arm with the motor and hand-grip.

The sharpener design provides for either a bench-or wall-mount installation.

1. When installing on a bench, place the sharpener on the edge of the bench to the stop (Fig. 1) and screw it to the desk using the holes in the base.

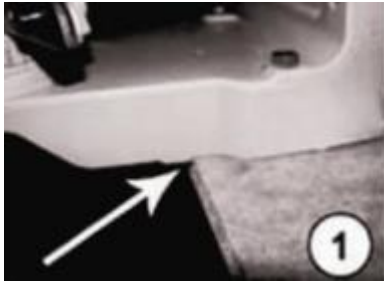

2. When mounting on the wall, use the respective holes in the vertical part of the base.
3. After the bench top installation, fit the arm in the base, inserting the pilot pin and securing it with a hexagonal screw (Fig.2).



4. Now, fit a washer (included) on the rear side screw and screw on the setting wheel (Fig.3).



5. Screw the hand piece onto the bolt in the grinding disc body (Fig.4).



6. Secure the grinding disc guard using the supplied screws and a wrench (Fig.5).



7. To be able to install the disc, it is necessary to unscrew the auxiliary flange (Fig.6).



## Before Each Use

### **⚠WARNING**

- Inspect the whole condition of the sharpener for good working condition.
- Check the disc you are about to use for damages prior to installation.

## Operating Instructions

### **⚠WARNING**

- Wear the proper protective equipment including ANSI Z87.1 compliant eye protection, NIOSH compliant breathing protection, and hearing protection.
- Do not use grinding wheels that have a max RPM less than the marked RPM rating on the tool.
- Keep hands clear from grinding wheel during use.
- Electric shock hazard. Do not expose to rain or use in damp locations.
- Do not use for wet grinding.
- Do not use wheel if cracked or chipped.
- Disconnect tools before servicing; when changing accessories, such as blades, bits, cutters, and the like.
- Reduce the risk of unintentional starting. Make sure switch is in off position before plugging in.
- Direction of feed. Feed work into a blade or cutter against the direction of rotation of the blade or cutter only.

- When using the sharpener outdoors, always use an outdoor rated extension cord with a splash-proof plug and socket.
- Do not use a caustic solution to clean plastic parts.
- Do not use the sharpener in the proximity of flammable liquids and vapors.
- Not for use by or around children.

### Grinding Disk Replacement

1. After you have removed the ancillary flange, you can insert the grinding disc in the body from below. See that the ancillary flange and the disc butt against each other (Fig.7).



2. To avoid damage to the disc, do not over tighten screws. The grinding disc on the hub torque is 7 Nm. Use a torque wrench. Now, the grinding disc guard should be secured (Fig.8).

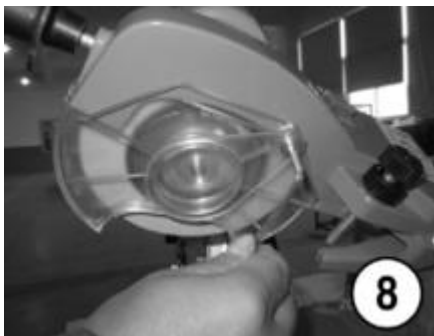

3. After installing the disc, run the machine and make sure the disc is not vibrating or spinning incorrectly. If it is, promptly turn off the sharpener and unplug the power cord before attempting to correct the fault.
4. The sharpener has a zero voltage circuit breaker, which is disabled during an outage and will prevent any unexpected restarting of the machine after the power supply is restored. Using the sharpening stone and clamping plate, sharpen the disc to obtain the required profile. As always, be careful while working.

### Grinding

1. With the clamping screw adjusted, the vise angle set up (Note: RH and LH teeth to be differentiated), and the top plate angle preset, lower the grinding disc to the tooth. The grinding depth may be set by adjusting the set screw (K).



2. Some types of chains require that the clamping screw be tilted by 5°-10°.
3. Now, the sharpener may be switched on and the chain grinding may be started by gently pressing the disc on the chain. Adjust the pressure as necessary. Mark the start of grinding with a piece of chalk and grind all the teeth in one direction, then turn the clamping screw (mind the angle) and grind the teeth in the opposite direction.
4. With worm chains, the lateral guide position (Fig.10, Position M) should be set so the grinding disc doesn't touch the guide.

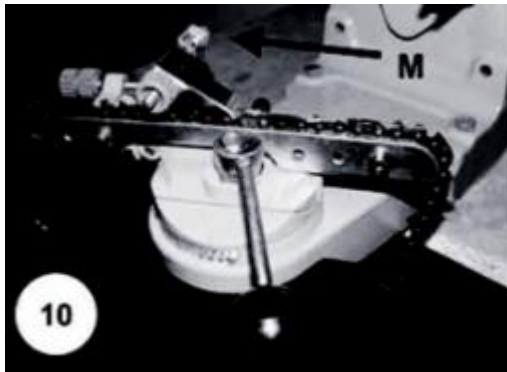

### After Each Use

#### **⚠WARNING**

- Keep the sharpener clean, especially after grinding, and check for any damage.
- Do not use a caustic solution to clean plastic parts.
- Do not use the sharpener in the proximity of flammable liquids and vapors.

### Maintenance

Maintain the product by adopting a program of conscientious repair and maintenance in accordance with the following recommended procedures. It is recommended that the general condition of any tool be examined before it is used. Keep your tool in good repair. Keep all cutting tools sharp and clean. Properly maintained cutting tools with sharp cutting edges are less likely to bind and are easier to control. Keep handles dry, clean, and free from oil and grease. The following chart is based on a normal operation schedule.

Maintenance Interval	Maintenance Point
Before Use	Inspect the sharpener for good working condition.
After Use	Store it in a dry and clean place. Wipe external surfaces of the sharpener with a clean cloth.

## Troubleshooting

Use the table below to troubleshoot problems before contacting service personnel or your local dealer. If the problem continues after troubleshooting, call your local dealer for assistance.

Failure	Possible Cause	Corrective Action
Sharpener will not start.	Cord not connected.	Check that cord is plugged in.
	No power at outlet.	Check power at outlet. If outlet is unpowered, turn off tool and check circuit breaker. If breaker is tripped, make sure circuit is right capacity for sharpener and circuit has no other loads.
	Internal damage or wear. (Carbon brushes or switch, for example.)	Have technician service sharpener.
Sharpener operates slowly.	Extension cord too long or wire size too small.	Eliminate use of extension cord. If an extension cord is needed, use one with the proper diameter for its length and load.
Sharpener is overheating.	Forcing sharpener to work too fast.	Allow sharpener to work at its own rate.
	Accessory dull or damaged.	Keep cutting accessories sharp. Replace as needed.

## Parts Diagram

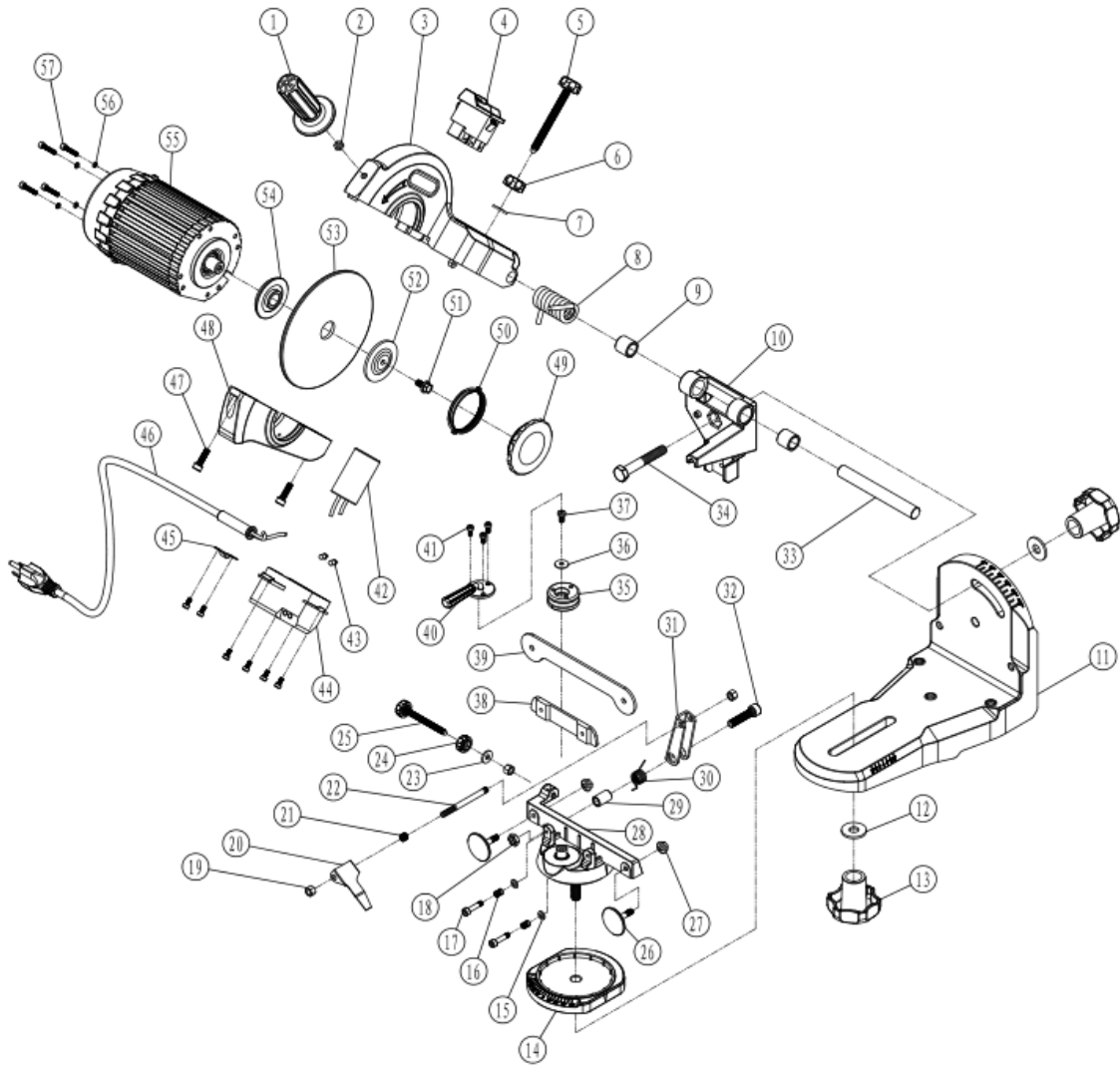

## Parts List

Reference	Part Description	Quantity
1	Handle	1
2	Hex Nut M6	1
3	Motor Holder	1
4	Switch	1
5	Adjusting Bolt 8	1
6	Adjusting Screw 8	1
7	Rubber Mat 8	1
8	Big Tensional Spring	1
9	Shaft Sleeve	2
10	Shaft Stand	1
11	Base	1
12	Flat Washer 11*28*25	2
13	Tightening Knob	2
14	Fixed Disc	1
15	Flat Washer 5*1	2

Reference	Part Description	Quantity
16	Small Pressure Spring A	2
17	Inner Hex Cylindrical Screw M5*22	2
18	Hex Nut M8	1
19	Hex Nut M6	3
20	Positioning Plate	1
21	Small Pressure Spring B	1
22	Stud M6*65	1
23	Rubber Mat 6	1
24	Adjusting Nut 6	1
25	Adjusting Bolt 6	1
26	Guide Wheel B	2
27	Hex Nut M6	2
28	Fixed Stand B	1
29	Guide Cover	1
30	Small Tensional Spring	1
31	Locating Rod	1
32	Inner Hex Cylindrical Screw M8*35	1
33	Connecting Axis	1
34	Bolt M10*65	1
35	Cam	1
36	Flat Washer 5*15*1	1
37	Bolt M5*10	1
38	Out Plate	1
39	Inner Plate	1
40	Dia Bottom	1
41	Inner Cylindrical Screw M4*8	9
42	Start Capacitor	1
43	LED Light	2
44	Down Cover	1
45	Pressing Plate	1
46	Power Cord	1
47	Inner Hex Cylindrical Screw M6*20	2
48	Grinding Wheel Cover	1
49	Cover	1
50	Connecting Ring	1
51	Hex Bolt M6*15	1
52	Pressing Plate	1
53	Grinding Wheel	1
54	Location Plate	1
55	Motor	1
56	Spring Washer 4*1	4
57	Inner Hex Cylindrical Screw M4*20	4

## Replacement Parts

- For replacement parts and technical questions, please call Customer Service at **1-800-222-5381**.
- Not all product components are available for replacement. The illustrations provided are a convenient reference to the location and position of parts in the assembly sequence.
- When ordering parts, the following information will be required: item description, item model number, item serial number/item lot date code, and the replacement part reference number.
- The distributor reserves the rights to make design changes and improvements to product lines and manuals without notice.

## Limited Warranty

Northern Tool and Equipment Company, Inc. ("We" or "Us") warrants to the original purchaser only ("You" or "Your") that the Strongway product purchased will be free from material defects in both materials and workmanship, normal wear and tear excepted, for a period of one year from date of purchase. The foregoing warranty is valid only if the installation and use of the product is strictly in accordance with product instructions. There are no other warranties, express or implied, including the warranty of merchantability or fitness for a particular purpose. If the product does not comply with this limited warranty, Your sole and exclusive remedy is that We will, at our sole option and within a commercially reasonable time, either replace the product or product component without charge to You or refund the purchase price (less shipping). This limited warranty is not transferable.

### Limitations on the Warranty

This limited warranty does not cover: (a) normal wear and tear; (b) damage through abuse, neglect, misuse, or as a result of any accident or in any other manner; (c) damage from misapplication, overloading, or improper installation; (d) improper maintenance and repair; and (e) product alteration in any manner by anyone other than Us, with the sole exception of alterations made pursuant to product instructions and in a workmanlike manner.

### Obligations of Purchaser

You must retain Your product purchase receipt to verify date of purchase and that You are the original purchaser. To make a warranty claim, contact Us at 1-800-222-5381, identify the product by make and model number, and follow the claim instructions that will be provided. The product and the purchase receipt must be provided to Us in order to process Your warranty claim. Any returned product that is replaced or refunded by Us becomes our property. You will be responsible for return shipping costs or costs related to Your return visit to a retail store.

### Remedy Limits

Product replacement or a refund of the purchase price is Your sole remedy under this limited warranty or any other warranty related to the product. We shall not be liable for: service or labor charges or damage to Your property incurred in removing or replacing the product; any damages, including, without limitation, damages to tangible personal property or personal injury, related to Your improper use, installation, or maintenance of the product or product component; or any indirect, incidental or consequential damages of any kind for any reason.

### Assumption of Risk

You acknowledge and agree that any use of the product for any purpose other than the specified use(s) stated in the product instructions is at Your own risk.

### Governing Law

This limited warranty gives You specific legal rights, and You also may have other rights which vary from state to state. Some states do not allow limitations or exclusions on implied warranties or incidental or consequential damages, so the above limitations may not apply to You. This limited warranty is governed by the laws of the State of Minnesota, without regard to rules pertaining to conflicts of law. The state courts located in Dakota County, Minnesota shall have exclusive jurisdiction for any disputes relating to this warranty.



Distributed by:

Northern Tool & Equipment Company, Inc.

Burnsville, Minnesota 55306

[www.northerntool.com](http://www.northerntool.com)

Made in China.