

ULTRA-TOW™

Owner's Manual

Instructions for Installation and Maintenance of Axle Spindle

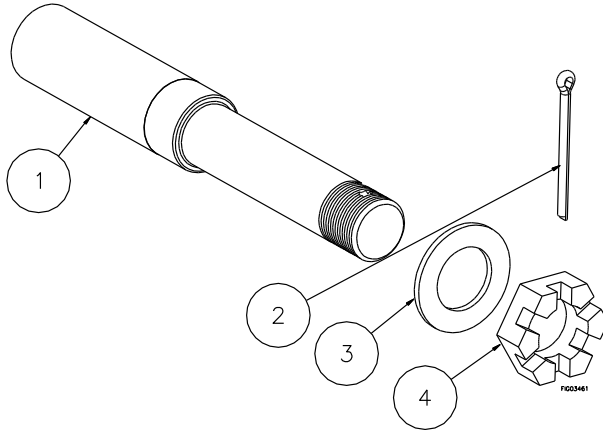

Ref #	Description	#5712451	#5712452	#5712453	#5712454	#5712455
1	Spindle	N/A	N/A	N/A	N/A	N/A
2	Cotter Pin					
3	Washer	Kit# 783931	Kit# 783931	Kit# 783931	Kit# 783931	Kit# 783931
4	Castle Nut					

Spindle Specifications

Item Number	#5712451	#5712452	#5712453	#5712454	#5712455
Rating(lbs.)	1250 lbs.	1350 lbs.	1250 lbs	1750 lbs	1750 lbs
Spindle Type	Straight	Straight	Straight	Tapered	Tapered
Inner Bearing	1in.	1-1/16in.	1in.	1-3/8in.	1-3/8in.
Outer Bearing	1in.	1-1/16in.	1in.	1-1/16in.	1-1/16in.
Oil Seal Diameter	1-1/4in.	1-1/4in.	1-1/4in.	1-32/32in.	1-32/32in.

Maintenance

Item	Function Required	When
Bearings	Inspect for wear, clean and repack	12 Months or 6000 Miles
Seals	Inspect for leakage, Replace if worn	12 Months or 6000 Miles
Castle Nut	Check torque value and tightness	12 Months or 6000 Miles

WARNING

READ and UNDERSTAND this manual completely before installing this spindle.

Welding a spindle requires that you have the proper equipment and have the skill to apply a proper weld. If you are not comfortable with your welding capabilities, have a qualified welder assemble your spindle.

Any Questions, Comments, Problems or Parts Orders

Call Product Support 1-800-222-5381

Safety – During Welding/Installation/Towing

- **Read manual.** Do not allow anyone to install this spindle who has not read this Owner's Manual.
- **Personal protective equipment.** Always wear protective clothing and safety glasses or goggles during installation.
- **Inspection.** It is important to clean and inspect the spindle for damage prior to welding and installing the hub. If the spindle is damaged, replace the spindle before installing the hub.
- **Spindle position.** Always ensure the spindle orientation is correct prior to welding. Improper camber and toe will result in abnormal tire wear and unsafe towing.
- **Torque values.** Always use a torque wrench when installing lug bolts/nuts and the castle nut. Improperly torqued bolts and nuts may cause broken bolts, bearing failure, loose wheels, and wheel separation.
- **Read instructions.** Review towing safety instructions in your towing vehicle manual.
- **Securely attached.** Check trailer hitch for signs of wear.
- **Tires.** Be sure tires are fully inflated and in good repair before towing. When adding air to tires, do not over-inflate -- serious injury could occur if tire explodes; wear safety glasses.
- **Loading the trailer.** Load the trailer so that the tongue weight is approximately 10% of the total load of the trailer.
- **Overloading.** Make sure the trailer load does not exceed the load ratings for the trailer components. This includes tires, axles, hubs, ball coupler, safety chains, and trailer design
- **Periodic maintenance.** Perform periodic maintenance as directed in this manual to keep the trailer hub in safe working condition.

Step 1

- Weld spindle to trailer axle.
- Ensure proper camber and toe.
- Use appropriate welding equipment and materials for welding SAE 1045 steel.

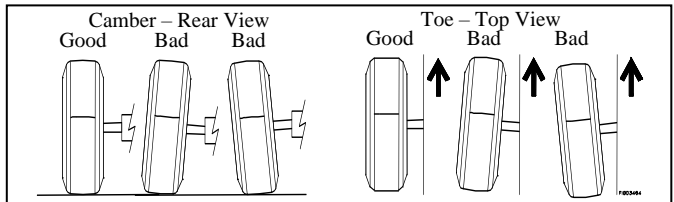

Step 2

- Slide new hub onto spindle.
- Using a torque wrench, tighten the new castle nut to 30-40 foot-lbs. Turn hub to ensure proper bearing seating.
- Loosen the castle nut until loose enough to turn the castle nut with your fingers.
- Re-tighten the castle nut until finger tight.

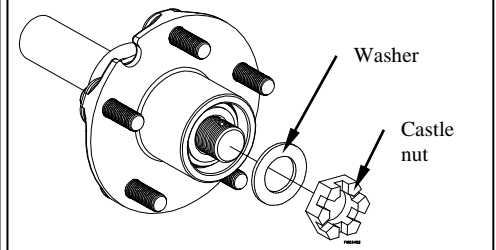

Step 3

- Install cotter pin through the hole in the spindle.
- If the hole is covered by the castle nut, loosen the castle nut to the nearest hole so that the cotter pin can be installed.
- The hub should rotate freely when spun by hand, and there should be no movement when the hub is pulled back and forth.
- Bend the legs of the cotter pin to ensure the cotter pin and castle nut will not loosen.
- Install dust cap.

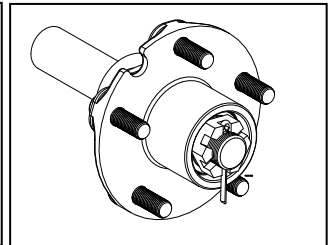

Limited Warranty

Ultra-Tow products are warranted to be free from defects in workmanship and material under normal service and use for two years from the date of purchase. This limited warranty shall not cover any damage resulting from: 1) Abuse, improper installation, repair or modification including improper wheel nut torque. 2) Overloading. 3) Damage resulting from the vehicle being involved in an accident or a natural disaster. 4) Failure to perform proper maintenance. This warranty is limited to replacement of defective parts, if any, and does not cover consequential damage to property or persons.

ULTRA-TOW™

Distributed by
Northern Tool + Equipment Co., Inc.
Burnsville, Minnesota 55306-6936
Assembled in Mexico with foreign components

MSPINDLE Rev. A.4