

FULLY ASSEMBLED SPRAYER: PPV-T7-2SSM

The following information covers both the steel-framed PPV-T7-2SSM-MM and the aluminum-framed PPV-T7-2SSM-MM-AL sprayers.

SPRAYER BREAKDOWN

FRAME

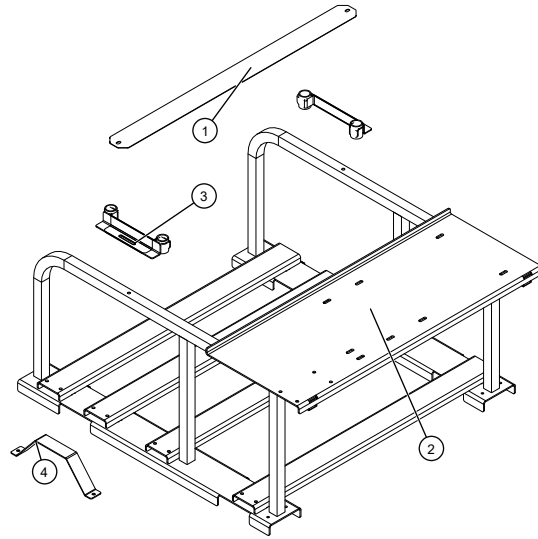

TANK

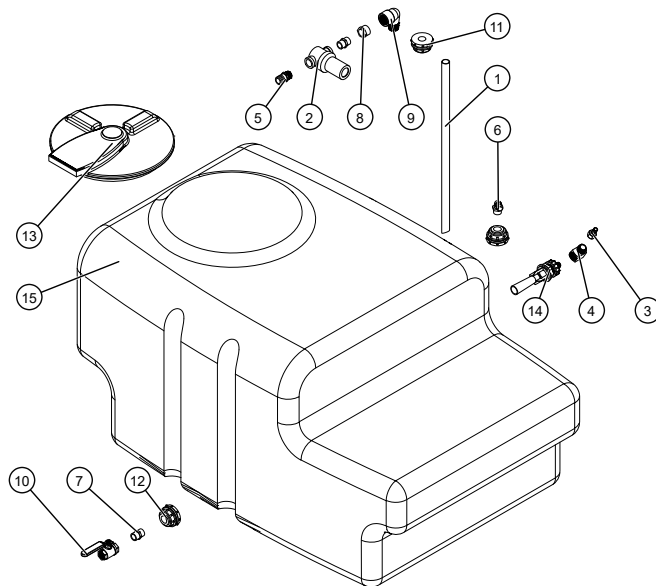

CLOSELY INSPECT ALL CONTENTS IN THE SHIPPING CARTON

- If you have damaged components: Contact the freight company that delivered the unit to file a claim.
- If you have missing components: Contact us at 800.825.5397.

ID	Part Number	Description	Qty
1	31-300011	Tank Strap	1
2	32-300012 or 32-300011	Steel Frame Weldment or Aluminum Frame	1
3	32-300009	Tank Holder	2
4	31-300036	Valve Guard	1

ID	Part Number	Description	Qty
1	100-8-00P	Poly Pipe	1
2	11263	Strainer	1
3	33-103605	1/2" MPT x 1/2" HB Fitting	1
4	33-103634	1/2" Elbow Fitting	1
5	3A34100	3/4" x 1" HB Straight Fitting	1
6	3EL34	3/4" MPT x 3/4" HB Elbow Fitting	1
7	3M34	3/4" MPT x 3/4" MPT Nipple	2
8	3RB10034	1" MPT x 3/4" FPT Reducer Bushing	1
9	3SE100	1" MPT x 1" FPT Elbow Fitting	1
10	BBV-34	3/4" Brass Ball Valve	1
11	BHF-100	Bulk Head Fitting	1
12	BHF34	Bulk Head Fitting	2
13	G-8170015	Hinged Tank Lid	1
14	G-8201002	Hydraulic Agitator	1
15	MXI-200	200 Gallon Tank	1

SPRAYER BREAKDOWN

ENGINE, HOSE REEL & PUMP

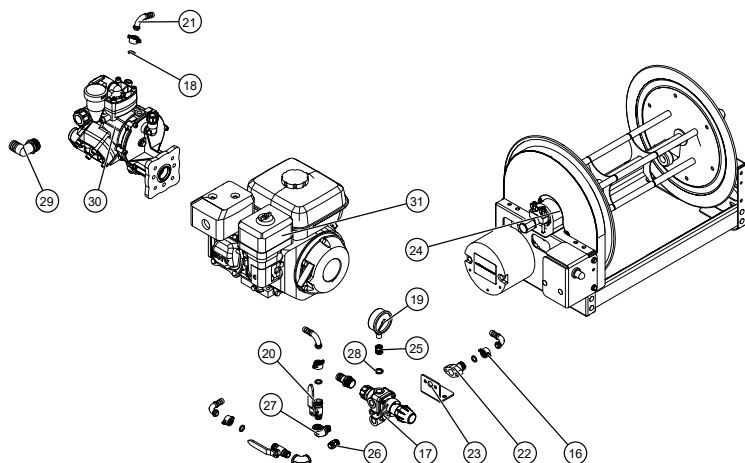

ID	Part Number	Description	Qty
16	1200.0038.00	Wing Nut	4
17	1204-0592-00	Regulator	1
18	1209.0013	Gasket	4
19	2154GXX1000	2.5" SST Gauge, 1000 PSI Max	1
20	2608.0029.00	Ball Valve	2
21	2803.0547.00	1/2" 90 Degree Coupling	4
22	0199.1427.00	Kit for NTM	1
23	31-300009	Regulator Mount	1
24		18" Hannay Electric Hose Reel	1
25	33-300016	3/8" MBSPT x 1/4" FBSPP Reducer Bushing	1
26	33-300017	3/8" BSPT Hex Nipple	2
27	33-300018	3/8" FBSPP x 3/8" FBSPP Elbow Fitting	2
28	33-300090	Compression Seal	1
29	3EL100	1" MPT x 1" HB Elbow Fitting	1
30	6114.0048.00	Comet APS41 Pump	1
31		Engine	1

WARNING

While this sprayer does come equipped with fork lift holes, the sprayer should be loaded into the truck or trailer prior to being filled with liquid to prevent any potential tipping issue due to weight or balance.

ASSEMBLY & OPERATION

This sprayer comes fully assembled from the manufacturer and only needs to be unpacked and prepared for use. Before operation refer to the engine and pump manuals to familiarize yourself with the engine controls, lubrication and maintenance. These manuals have been included with the sprayer.

Startup Inspection: Refer to the engine manual and ensure the correct kind and quantity of oil is added to the engine. Add fuel to the engine. Verify the pump is properly lubricated. Inspect the inside of the tank for any debris or parts. Ensure the inlet filter to the pump is clean of any debris and the screen is not plugged.

Startup: Fill the tank with clean water. Locate the pressure regulator and turn the knob counter clockwise to decrease the pressure. Start the engine per the manual instructions and allow it to warm up. Point the spray gun away from any person and in a safe direction to be sprayed. Press the spray gun trigger until water begins to spray from the wand. Adjust the pressure regulator to the desired pressure by viewing the pressure gauge.

Chemical: Add the proper amounts of chemical and water to the tank and the sprayer should be ready to spray.

CLEANING & STORAGE

Most spray materials are highly corrosive. The most important aspect of long dependable service from the sprayer is a thorough cleaning immediately following each use. In addition, the residue of one type of chemical could cause an undesirable effect when a different chemical is used for a different purpose.

The most effective cleaning method is to pump several rinses of clean water through the tank, pump, hoses, spray gun, etc. A neutralizing agent such as a solution of Nutra-Sol, a detergent or household ammonia as recommended by the chemical manufacturer can assist in removal of persistent chemicals. When the system is thoroughly cleaned, drain the tank, suction ling, pump, hoses, etc.

The following steps should be followed for the maintenance and storage of your sprayer.

1. Wash and flush out sprayer after completion of each phase of your program. Flush out sprayer when changing chemicals if there is a possibility of the chemicals being incompatible. Use of a detergent is advisable if the chemical manufacturer does not make specific cleaning recommendations. Flush system completely, including nozzles. Never use metal objects to open clogged nozzles.
2. Clean sprayer thoroughly before storing at the end of the spraying season. Permanent type anti-freeze added to the final rinse will leave a rust inhibiting film in parts of the sprayer.

SPRAY GUN

The SG-LS-030 spray guns comes with two additional nozzles (#1.5 & #4.0). Be sure to select the correct one for your intended use. Also note that the SG-LS-030 has a maximum operating pressure of 200psi(14 bar). For maintenance please refer to the spray gun manual included with the sprayer.