

# 50 Gallon Low Profile



**PAV-Q7-050M-MM**

Rev 1. May 2016

Note: Do not return product to the distributor/dealer for warranty works. Call Master Manufacturing at 320-340-6464 for any warranty work or replacement parts.

## **WARNING**

**While this sprayer does come equipped with fork lift holes, the sprayer should be loaded into the truck or trailer prior to being filled with liquid to prevent any potential tipping issue due to weight or balance.**

## **Introduction**

The purpose of this manual is to assist you in the assembly, operation and maintenance of your sprayers or accessories.

Please read through this manual completely too fully understand how to operate and maintain your equipment. This product has been manufactured to provide years of dependable service; proper operation and maintenance will ensure its dependability. Keep you manual in a safe, convenient place for future reference. Always mention the model and part number in any correspondence. Refer to the proper engine and pump manuals for your model for proper maintenance and operation.

## **Assembly/Operation**

This sprayer comes fully assembled from the manufacturer and only needs to be unpack and prepared for use. Before operation refer to the engine and pump manuals to familiarize yourself with the engine controls, lubrication and maintenance. These manuals have been included with the sprayer.

**Startup Inspection:** Refer to the engine manual and ensure the correct kind and quantity of oil is added to the engine. Add fuel to the engine. Verify the pump is properly lubricated. Inspect the inside of the tank for any debris or parts. Ensure the inlet filter to the pump is clean of any debris and the screen is not plugged.

**IMPORTANT: Before spraying chemicals, fill the tank half full of plain water to allow familiarization with the sprayer and to prevent waste of expensive chemicals.**

**Startup:** Fill the tank with clean water. Locate the pressure regulator and turn the knob counter clockwise to decrease the pressure. Start the engine per the manual instructions and allow it to warm up. Point the spray gun away from any person and in a safe direction to be sprayed. Press the spray gun trigger until water begins to spray from the wand. Adjust the pressure regulator to the desired pressure by viewing the pressure gauge.

**Chemical:** Add the proper amounts of chemical and water to the tank and the sprayer should be ready to spray.

## **Sprayer Maintenance**

A sprayer is a carefully designed and built machine that should provide many years of reliable service if properly cared for, the main rule in caring for any sprayer is: **KEEP IT CLEAN.** Neglect costs dollars in repairs, waster spray material and premature replacement of the sprayer.

## **Cleaning & Storage**

Most spray materials are highly corrosive. The most important aspect of long dependable service from the sprayer is a thorough cleaning immediately following each use. In addition, the residue of one type of chemical could cause an undesirable effect when a different chemical is used for a different purpose.

The most effective cleaning method is to pump several rinses of clean water through the tank, pump, hoses, spray gun, etc. A neutralizing agent such as a solution of Nutra-Sol, a detergent or household ammonia as recommended by the chemical manufacturer can assist in removal of persistent chemicals. When the system is thoroughly cleaned, drain the tank, suction line, pump, hoses, etc.

The following steps should be followed for the maintenance and storage of your sprayer.

1. Wash and flush out sprayer after completion of each phase of your program. Flush out sprayer when changing chemicals if there is a possibility of the chemicals being incompatible. Use of a detergent is advisable if the chemical manufacturer does not make specific cleaning recommendations. Flush system completely, including nozzles. Never use metal objects to open clogged nozzles.
2. Clean sprayer thoroughly before storing at the end of the spraying season. Permanent type anti-freeze added to the final rinse will leave a rust inhibiting film in parts of the sprayer.

## **Spray Gun**

The SG-LS-030 spray gun comes with a variety of nozzles, be sure to select the correct one for your intended use. Also note that the SG-LS-030 has a maximum operating pressure of 200psi(14 bar). For maintenance please refer to the spray gun manual included with the sprayer.

## **Warrant Parts Service**

Products sold shall be warranted from defects in workmanship and material when used within the service and scope for which they were designed for a period of one year from date of purchase. Warranty covers replacement parts ONLY> Contact Master Manufacturing for warrants parts at (800) 864-1649. Do not return product to your distributor/dealer. Please have your original sales receipt or other proof of purchase date when requesting any warranty parts. To ensure the correct parts are acquired always provide the model number of your sprayer and the part number and description obtained from the illustrated parts breakdown in this manual.

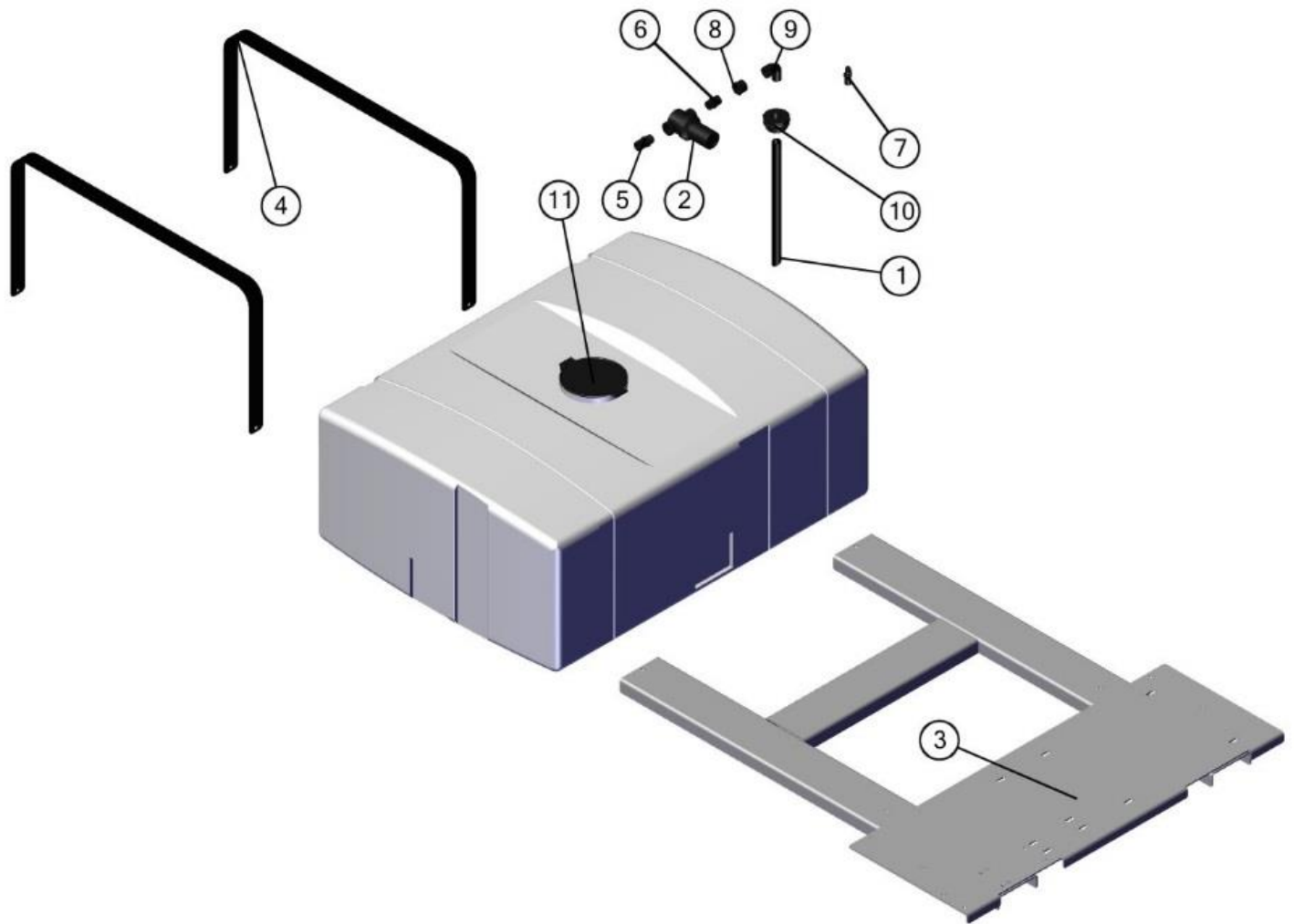

BOM ID	Name	Description	Qty
1	100-8-00P	PIPE, POLY SCHEDULE 80, 1`DIAx20FT , BLACK	1
2	11263	STRNR, 3/4" EPDM, 40M, Poly	1
3	32-300003	FRAME, WELDMENT, 50GAL, LOW PROFILE	1
4	31-300038	STRAP, TANK, 50GAL, LOW PROFILE	2
5	3A34100	STRAIGHT:3/4`MPTx1`HBPOLY	1
6	3M34	Nipple: 3/4" MPT x 3/4" MPT Poly	1
7	3NTL12-C	Elbow: NzThd-11/16MPS x 1/2"HB	1
8	3RB10034	Reducer Bush: 1"MPT x 3/4"FPT	1
9	3SE100	STR. ELB:1`MPTx1`FPT POLY	1
10	BHF100	Bulk Head Fitting	1
11	33-300010	TANK, 50GAL, LOW PROFILE	1

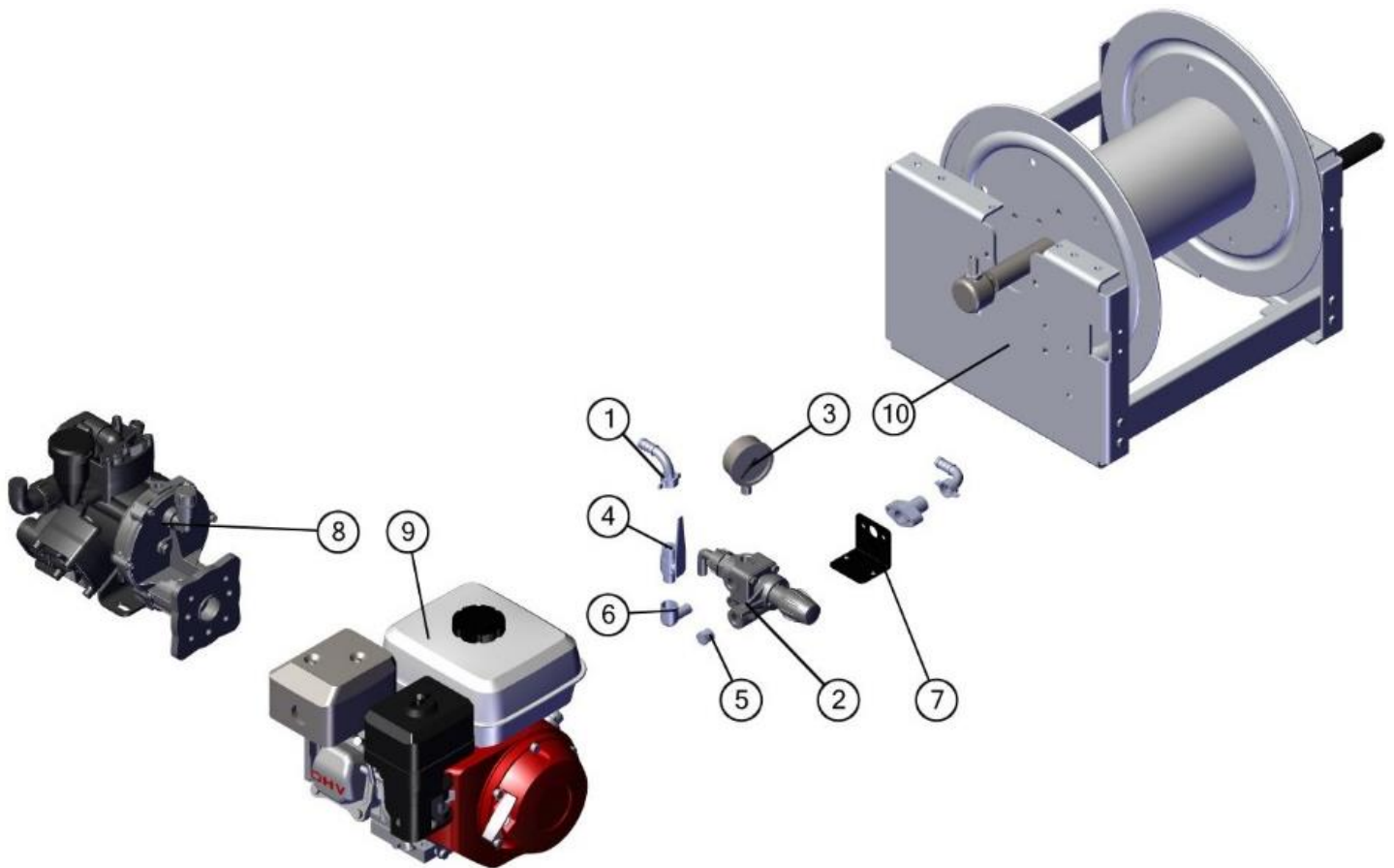

BOM ID	Name	Description	Qty
1	0199.1427.00	KIT FOR NTM(779224)	2
2	1204-0592-00	REGULATOR	1
3	2154GXX1000	GAUGE,2.5"SS 1/4"LM 1000PSI	1
4	2826.0029.00	BALL VALVE	1
5	304-F38	HEX PLUG:3/8"MPT-SS	1
6	304SE38	STR.ELB:3/8"MPTx3/8"FPT	1
7	31-300009	REGULATOR, MOUNT, SPACE SAVER	1
8	6114.0048.00	PUMP, APS41, PLASTIC COATED W/3/4" GEARBOX	1
9	33-103097	ENGINE, 6.5HP, HONDA GX200	1
10	HR-12ALF-M	HOSE REEL, 12" CENTER, ALUMINUM, MANUAL	1

