



Manual Chain Hoist

Owner's Manual



⚠ WARNING: Read carefully and understand all ASSEMBLY AND OPERATION INSTRUCTIONS before operating. Failure to follow the safety rules and other basic safety precautions may result in serious personal injury.

Items #57034, #57035, #57036, #57136, #57137

READ & SAVE THESE INSTRUCTIONS

Thank you very much for choosing an Ironton™ product!

For future reference, please complete the owner's record below:

Serial Number/Lot Date Code: _____

Purchase Date: _____

Save the receipt, warranty, and this manual. It is important that you read the entire manual to become familiar with this product before you begin using it.

This hoist is designed for certain applications only. Northern Tool and Equipment is not responsible for issues arising from modification or improper use of this product such as an application for which it was not designed. We strongly recommend that this product not be modified and/or used for any application other than that for which it was designed.

For technical questions, please call **1-800-222-5381**.

Table of Contents

Intended Use.....4

Technical Specifications4

Important Safety Information4

Specific Operation Warnings6

Operating Instructions.....7

Maintenance9

Parts Diagram9

Parts List10

Replacement Parts11

Limited Warranty12

Intended Use

The Ironton Manual Chain Hoist is a portable lifting device easily operated by a hand chain. It is suitable for use in garages, workshops, and warehouses for loading and unloading goods. It is advantageous for lifting work in open air grounds and places where a power supply is not available.

Technical Specifications

Model	#57034	#57035	#57036	#57137	#57136
Rated Capacity (lb.)	1100	2200	4400	6600	11,000
Lift Height (ft.)	10	10	10	10	10
Head Room (in.)	9-1/2	10-5/8	15	18-1/2	23-5/8
Load Chain Dia. (mm)	6	6	6	8	10

Important Safety Information

⚠WARNING

- Read and understand all instructions. Failure to follow all instructions may result in serious injury or property damage.
- The warnings, cautions, and instructions in this manual cannot cover all possible conditions or situations that could occur. Exercise common sense and caution when using this tool. Always be aware of the environment and ensure that the tool is used in a safe and responsible manner.
- Do not allow persons to operate or assemble the product until they have read this manual and have developed a thorough understanding of how it works.
- Do not modify this product in any way. Unauthorized modification may impair the function and/or safety and could affect the life of the product. There are specific applications for which the product was designed.
- Use the right tool for the job. DO NOT attempt to force small equipment to do the work of larger industrial equipment. There are certain applications for which this equipment was designed. This product will be safer and do a better job at the capacity for which it was intended. DO NOT use this equipment for a purpose for which it was not intended.
- Industrial or commercial applications must follow OSHA requirements.

⚠WARNING

WORK AREA SAFETY

- Inspect the work area before each use. Keep work area clean, dry, free of clutter, and well-lit. Cluttered, wet, or dark work areas can result in injury. Using the product in confined work areas may put you dangerously close to cutting tools and rotating parts.
- Do not use the product where there is a risk of causing a fire or an explosion; e.g., in the presence of flammable liquids, gases, or dust. The product can create sparks, which may ignite the flammable liquids, gases, or dust.
- Do not allow the product to come into contact with an electrical source. The tool is not insulated

and contact will cause electrical shock.

- Keep children and bystanders away from the work area while operating the tool. Do not allow children to handle the product.
- Be aware of all power lines, electrical circuits, water pipes, and other mechanical hazards in your work area. Some of these hazards may be hidden from your view and may cause personal injury and/or property damage if contacted.

⚠WARNING

PERSONAL SAFETY

- Stay alert, watch what you are doing, and use common sense when operating the tool. Do not use the tool while you are tired or under the influence of drugs, alcohol, or medication. A moment of inattention while operating the tool may result in serious personal injury.
- Dress properly. Do not wear loose clothing, dangling objects, or jewelry. Keep your hair, clothing and gloves away from moving parts. Loose clothes, jewelry, or long hair can be caught in moving parts. Air vents on the tool often cover moving parts and should be avoided.
- Wear the proper personal protective equipment when necessary. Use ANSI Z87.1 compliant safety goggles (not safety glasses) with side shields, or when needed, a face shield. Use a dust mask in dusty work conditions. Also use non-skid safety shoes, hardhat, gloves, dust collection systems, and hearing protection when appropriate. This applies to all persons in the work area.
- Do not overreach. Keep proper footing and balance at all times.
- Remove keys or wrenches before connecting the tool to an air supply, power supply, or turning on the tool. A wrench or key that is left attached to a rotating part of the tool may cause personal injury.
- Secure the work with clamps or a vise instead of your hand when practical. This safety precaution allows for proper tool operation using both hands.

⚠CAUTION

HOIST USE AND CARE

- Do not force the hoist. Products are safer and do a better job when used in the manner for which they are designed. Plan your work, and use the correct product for the job.
- Check for damaged parts before each use. Carefully check that the product will operate properly and perform its intended function. Replace damaged or worn parts immediately. Never operate the product with a damaged part.
- Do not use a product with a malfunctioning switch. Any power tool that cannot be controlled with the power switch is dangerous and must be repaired by an authorized service representative before using.
- Disconnect the power/air supply from the product and place the switch in the locked or off position before making any adjustments, changing accessories, or storing the tool. Such preventive safety measures reduce the risk of starting the tool accidentally.
- Store the product when it is not in use. Store it in a dry, secure place out of the reach of children.

Inspect the tool for good working condition prior to storage and before re-use.

- Use only accessories that are recommended by the manufacturer for use with your product. Accessories that may be suitable for one product may create a risk of injury when used with another tool. Never use an accessory that has a lower operating speed or operating pressure than the tool itself.
- Keep guards in place and in working order. Never operate the product without the guards in place.
- Do not leave the tool running unattended.

Specific Operation Warnings

⚠WARNING

- To prevent serious injury or property damage, read and understand this manual before operating.
- To reduce the risk of injury, operate hoist using manual power only.
- Do not exceed the rated load capacity.
- Do not use hoist with extension on lever handle.
- Do not use in a way that causes either hook to be side loaded.
- Do not use chain hoist as a sling.
- Do not support load on hook unless hook is designed for tip loading.
- Do not operate if restricted from forming a straight line from hook to hook in the direction of loading.
- Inspect for damaged parts before use. Do not use if damaged.
- Examine each chain link for damage or weak links before use. Do not operate a hoist with twisted, kinked or damaged chain.
- Do not lift people, animals, or loads above either.
- Do not pull chain at an angle.
- Keep bystanders away while hoist is loaded.
- Not for use by or around children.

Before Each Use

⚠WARNING

- Before operating, make sure that the hoist is not in the free chain mode and always check that the selector is placed in the proper position.
- DO NOT touch or operate the hoist's free knob while a load is applied to the hoist.
- Inspect for damaged parts before use. Do not use if damaged.
- Examine each chain link for damage or weak links before use. Do not operate a hoist with twisted, kinked or damaged chain.

Operating Instructions

⚠WARNING

- To reduce the risk of injury, operate hoist using manual power only.
 - Do not exceed the rated load capacity.
 - Do not use hoist with extension on lever handle.
 - Do not use in a way that causes either hook to be side loaded.
 - Do not use chain hoist as a sling.
 - Do not support load on hook unless hook is designed for tip loading.
 - Do not operate if restricted from forming a straight line from hook to hook in the direction of loading.
-
- Properly seat the suspension hook on the supporting structure at its intended load bearing point (Figure 1). Do not allow the hook hitch to support any part of the load. Do not apply the load to the point of the hook (Figure 1).

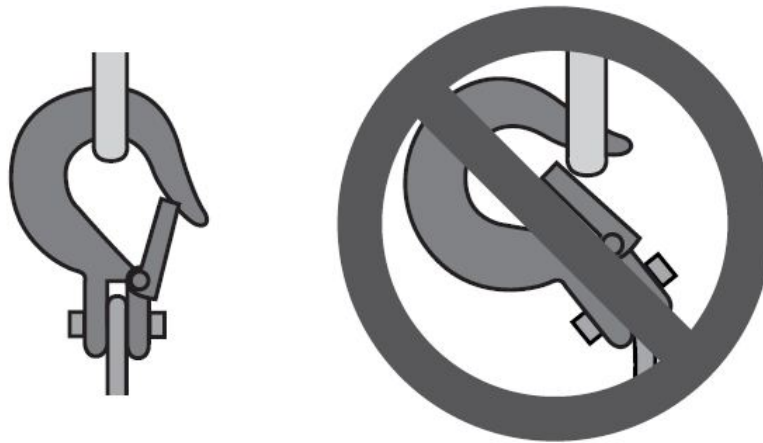

Figure 1

Correct and incorrect suspension hook attachment

- Properly seat the sling or other device in the base (bowl or saddle) of the hook (Figure 2). Do not allow the hook hitch to support any part of the load.
- Do not apply the load to the point of the hook (Figure 2).

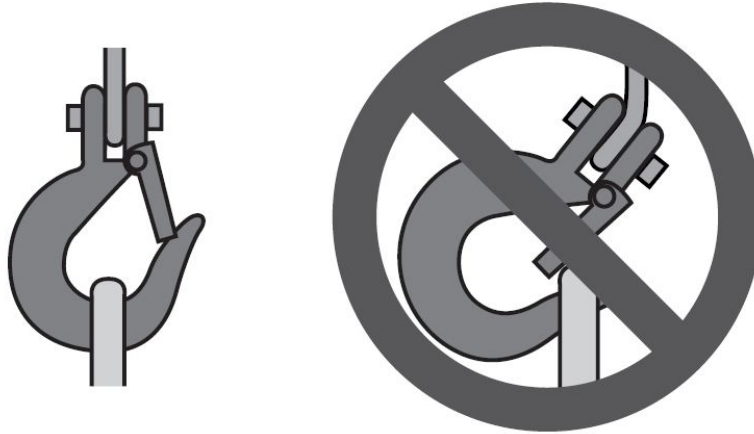
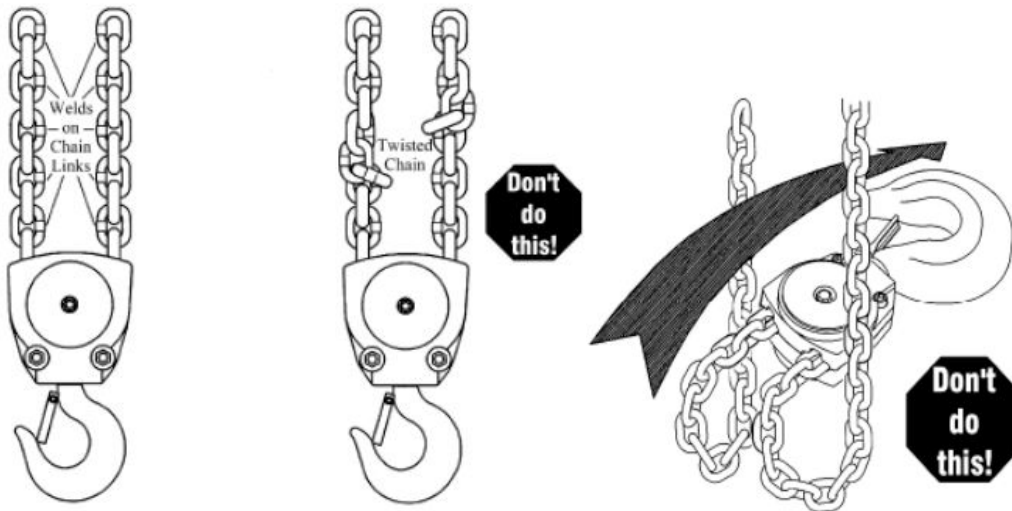

Figure 2

Correct and incorrect hook attachment



1. Judge the weight of the load to be lifted and make sure the weight is not over the rated capacity of the hoist. Never overload the hoist.
2. Careful inspection should be made to the parts, such as hooks, load chain, braking device, etc., and the lubrication of the hoist. The chain hoist can only be put into operation when it is in good condition.
3. Before lifting, inspect the hooks to see whether they are securely attached. Obliquity of the hooks and load suspension at the hook tip are not permissible. For perfect performance of the hoist, the load chain should be kept vertically straight without twisting to prevent it from tangling.

Maintenance

Maintain the product by adopting a program of conscientious repair and maintenance in accordance with the following recommended procedures. It is recommended that the general condition of any tool be examined before it is used. Keep your tool in good repair. Keep handles dry, clean, and free from oil and grease. The following chart is based on a normal operation schedule.

Maintenance Interval	Maintenance Point
Daily after operating	Clean the chain block from dirt and keep it in a dry place away from dust and corrosion.
Quarterly (every 3 months)	Clean off load chain, and then lubricate load chain links with lithium grease. Apply grease to inner surfaces of load chain, where the links rub against each other.

Parts Diagram

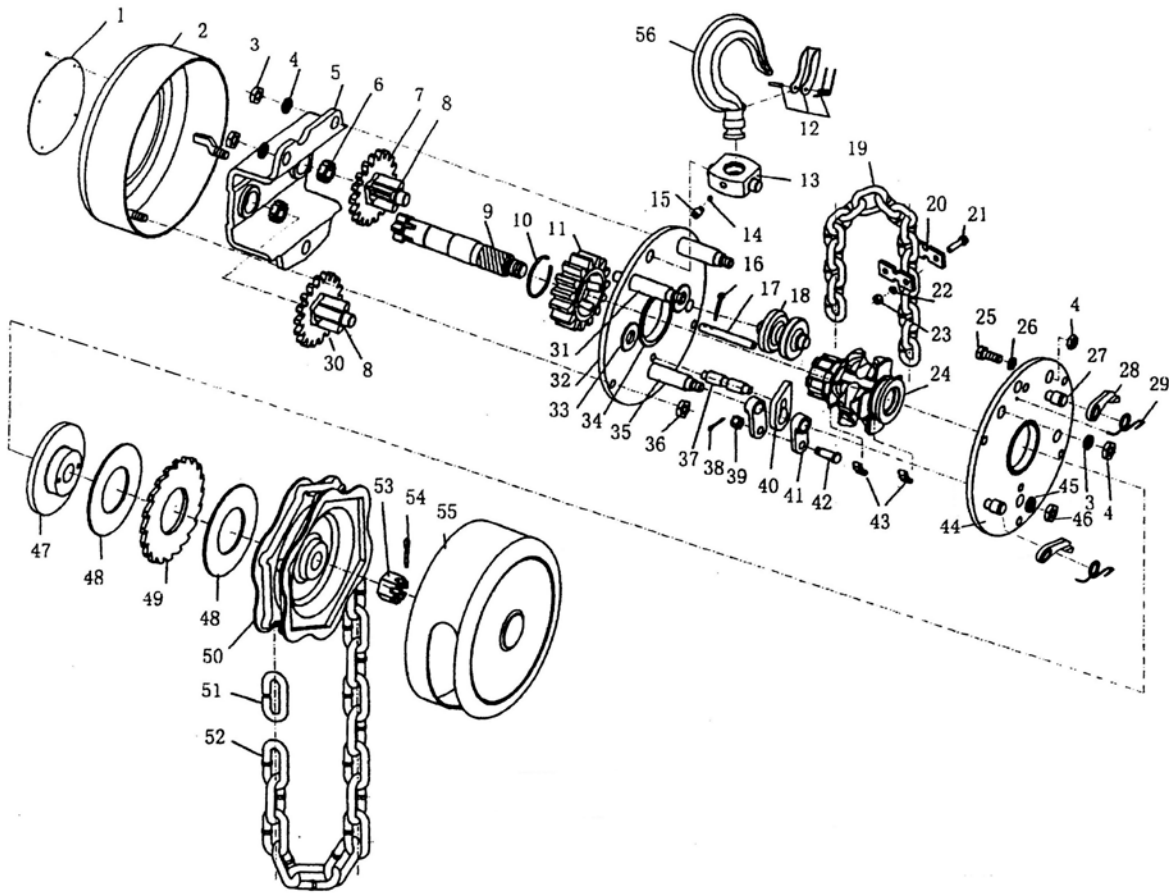

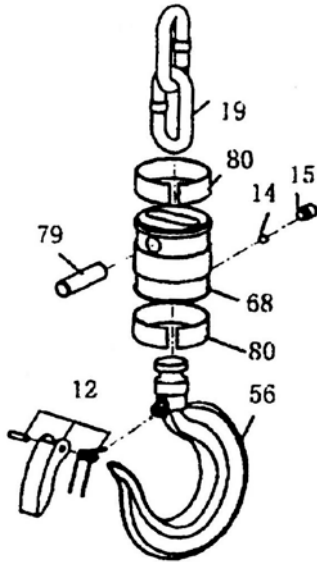

For 1100, 2200lb hoist

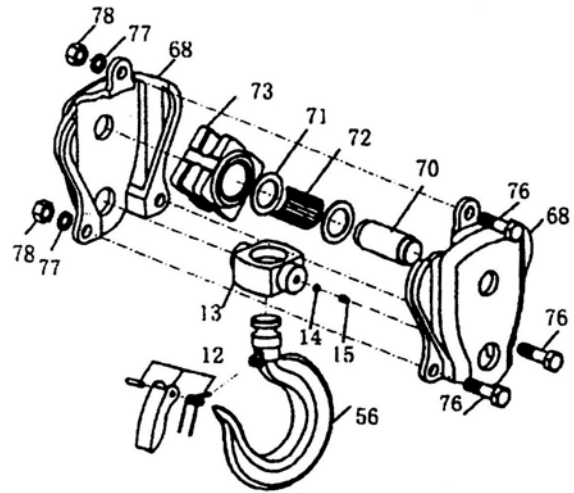

For 4400, 6600, 11000lb hoist

Parts List

Reference	Part Number	Part Description	Quantity
1	1	Name Plate	1
2	2	Sheet Cover	1
3	3	Nut	2
4	4	Washer	2
5	5	Gear Cover	1
6	6	Roller	1
7	7	Disc Gear A	1
8	8	Pinion Shaft	1
9	9	Driving Shaft	1
10	10	Circle	1
11	11	Splined Gear	1
12	12	Safety Latch	2
13	13	Hook Holder	1
14	14	Steel Ball	1
15	15	Screw	1
16	16	Cotter Pin	2
17	17	Pin	1
18	18	Chain Guide	1
19	19	Load Chain	1
20	20	Chain Stop	1
21	21	Bolt	1
22	22	Washer	1
23	23	Nut	1
24	24	Load Sheave	1
25	25	Bolt	1
26	26	Washer	1
27	27	Pawl Pin	2
28	28	Pawl	2
29	29	Pawl Spring	2
30	30	Disc Gear B	1
31	31	Stay Bolt B	1
32	32	Gear Side Plate	1

Reference	Part Number	Part Description	Quantity
33	33	Bearing Race	1
34	34	Bearing Race	1
35	35	Stay Bolt A	1
36	36	Nut	1
37	37	Stripper Pin	1
38	38	Split Pin	1
39	39	Slotted Nut	1
40	40	Stripper	1
41	41	Chain Anchor Plate	1
42	42	Chain Pin	1
43	43	Roller	2
44	44	Wheel Side Plate	1
45	45	Washer	1
46	46	Nut	1
47	47	Brake Seat	1
48	48	Friction Disc	2
49	49	Ratchet	1
50	50	Hand wheel	1
51	51	Connecting Link	1
52	52	Hand Chain	1
53	53	Slotted Nut	1
54	54	Cotter Pin	1
55	55	Wheel Cover	1
56	56	Hook	2
68	68	Bottom Hook Block	1
70	70	Sheave Shaft	1
71	71	Retaining Ring	1
72	72	Needle	1
73	73	Idle Sheave	1
76	76	Bolt	3
77	77	Washer	2
78	78	Nut	2
79	79	Chain Pin	1
80	80	Anchor Ring	1

Replacement Parts

- For replacement parts and technical questions, please call Customer Service at **1-800-222-5381**.
- Not all product components are available for replacement. The illustrations provided are a convenient reference to the location and position of parts in the assembly sequence.
- When ordering parts, the following information will be required: item description, item model number, item serial number/item lot date code, and the replacement part reference number.
- The distributor reserves the rights to make design changes and improvements to product lines and manuals without notice.

Limited Warranty

Northern Tool and Equipment Company, Inc. ("We" or "Us") warrants to the original purchaser only ("You" or "Your") that the Ironton product purchased will be free from material defects in both materials and workmanship, normal wear and tear excepted, for a period of **90 days** from date of purchase. The foregoing warranty is valid only if the installation and use of the product is strictly in accordance with product instructions. There are no other warranties, express or implied, including the warranty of merchantability or fitness for a particular purpose. If the product does not comply with this limited warranty, Your sole and exclusive remedy is that We will, at our sole option and within a commercially reasonable time, either replace the product or product component without charge to You or refund the purchase price (less shipping). This limited warranty is not transferable.

Limitations on the Warranty

This limited warranty does not cover: (a) normal wear and tear; (b) damage through abuse, neglect, misuse, or as a result of any accident or in any other manner; (c) damage from misapplication, overloading, or improper installation; (d) improper maintenance and repair; and (e) product alteration in any manner by anyone other than Us, with the sole exception of alterations made pursuant to product instructions and in a workmanlike manner.

Obligations of Purchaser

You must retain Your product purchase receipt to verify date of purchase and that You are the original purchaser. To make a warranty claim, contact Us at 1-800-222-5381, identify the product by make and model number, and follow the claim instructions that will be provided. The product and the purchase receipt must be provided to Us in order to process Your warranty claim. Any returned product that is replaced or refunded by Us becomes our property. You will be responsible for return shipping costs or costs related to Your return visit to a retail store.

Remedy Limits

Product replacement or a refund of the purchase price is Your sole remedy under this limited warranty or any other warranty related to the product. We shall not be liable for: service or labor charges or damage to Your property incurred in removing or replacing the product; any damages, including, without limitation, damages to tangible personal property or personal injury, related to Your improper use, installation, or maintenance of the product or product component; or any indirect, incidental or consequential damages of any kind for any reason.

Assumption of Risk

You acknowledge and agree that any use of the product for any purpose other than the specified use(s) stated in the product instructions is at Your own risk.

Governing Law

This limited warranty gives You specific legal rights, and You also may have other rights which vary from state to state. Some states do not allow limitations or exclusions on implied warranties or incidental or consequential damages, so the above limitations may not apply to You. This limited warranty is governed by the laws of the State of Minnesota, without regard to rules pertaining to conflicts of law. The state courts located in Dakota County, Minnesota shall have exclusive jurisdiction for any disputes relating to this warranty.



Distributed by:

Northern Tool & Equipment Company, Inc.

Burnsville, Minnesota 55306

www.northerntool.com

Made in China