

FORK MOUNTED TRASH BIN COMPACTOR - FWBC-4242-4-BC

APPROX WEIGHT: 4000 lbs.
 DOES NOT INCLUDE WEIGHT OF POWER OR PACKAGING!!!

*** ANY ADDITIONS, DELETIONS, OR OMISSIONS MUST BE CORRECTED ON THIS DRAWING AS THIS DRAWING WILL BE CONSIDERED ALL INCLUSIVE ***

ALL GRAPHICS PROVIDED ARE FOR REFERENCE ONLY. IF CERTAIN DIMENSIONS ARE CRITICAL PLEASE VERIFY THOSE DIMENSIONS WITH YOUR SALESPERSON

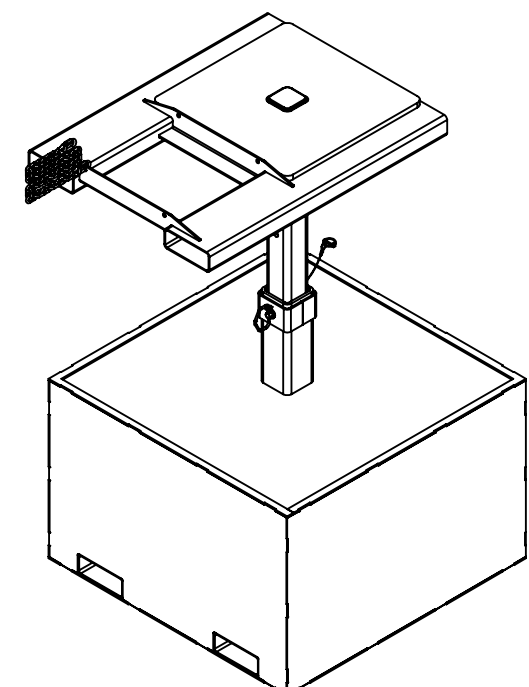
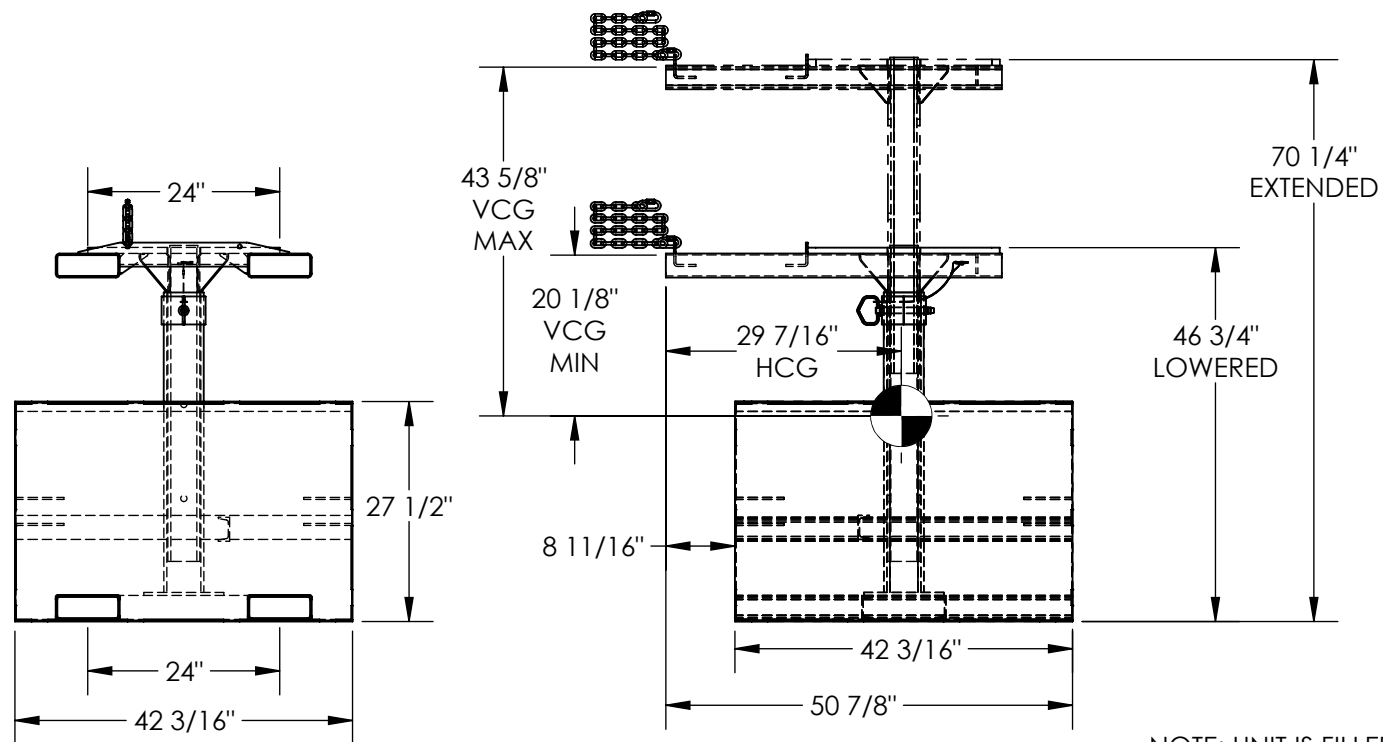

NOTE: UNIT IS FILLED WITH GRAVEL OR LIMESTONE AGGREGATE CONCRETE.

DIMENSION TOLERANCE ± 1/4"

STANDARD FEATURES

- MODEL NUMBER IS FWBC-4242-4-BC
- OVERALL WIDTH IS 42 3/16"
- OVERALL LENGTH IS 50 7/8"
- EXTENDED HEIGHT IS 70 1/4"
- LOWERED HEIGHT IS 46 3/4"
- FORK POCKETS ARE 7 1/2" x 2 1/2"
- USABLE ON 24" CENTERS
- DURABLE LIQUID PAINT BLUE FINISH
- BASE FILLED WITH CONCRETE
- UNIT WEIGHT 4,000 LBS APPROX.
- CENTER OF GRAVITY CALCULATED W/ WEIGHT
- VERTICAL CENTER OF GRAVITY IS 43 5/8" MAX AND 20 1/8" MIN
- HORIZONTAL CENTER OF GRAVITY IS 29 7/16"

APPROX. WEIGHT / LOAD = 4000 LBS.
 MINIMUM EFFECTIVE THICKNESS = LESS THAN 1"
 NEVER EXCEED LOAD CENTER RATING PER FORKTRUCK MANUFACTURERS GUIDELINES.
 DO NOT USE THIS FORK TRUCK ATTACHMENT IF LOAD WILL EXCEED FORK TRUCK MANUFACTURER'S LOAD CENTER RATING

SPECIAL FEATURES

NONE

APPROVAL	I, THE UNDERSIGNED, AGREE THAT THE PRODUCT AS REPRESENTED SATISFIES DESIGN AND DIMENSION REQUIREMENTS. I ALSO ACKNOWLEDGE MY DUTY TO CONFIRM PRODUCT AND INSTALLATION COMPLIANCE WITH ALL APPLICABLE FEDERAL, STATE AND LOCAL REGULATIONS AND STANDARDS.	
	UNITS REQUIRING APPROVAL DRAWINGS OR MODIFIED ARE NON-RETURNABLE	
	[] As drawn	[] As marked
	Signed: _____	Date: _____
	Printed Name: _____	
LEAD TIME WILL START UPON RECEIPT OF SIGNED APPROVAL DRAWING		

DISTRIBUTOR'S NAME:		P.O.#
VESTIL MANUFACTURING		X
DRAWN BY: CJC		W.O.#
DATE: 5/31/2022		X
REFERENCE: X	SCALE: 1:24	SALES: X
QUOTED LEAD TIME: X	QUOTE # X	FILE NAME: 47-007-065