

ULTRA-TOW

WATERCRAFT TRAILER W/4.8-12in. OWNER'S MANUAL



WARNING: Read carefully and understand all INSTRUCTIONS before operating. Failure to follow the safety rules and other basic safety precautions may result in serious personal injury.

Item#s 5569360

ULTRA-TOW

WATERCRAFT TRAILER W/4.8-12in.
OWNER'S MANUAL

Thank you very much for choosing an Ironton Product! For future reference, please complete the owner's record below:

Model: _____ Purchase Date: _____

Save the receipt, warranty and these instructions. It is important that you read the entire manual to become familiar with this product before you begin using it.

This trailer is designed for certain applications only. The distributor cannot be responsible for issues arising from modification. We strongly recommend this trailer is not modified and/or used for any application other than that for which it was designed. If you have any questions relative to a particular application, DO NOT use the trailer until you have first contacted distributor to determine if it can or should be performed on the product.

For technical questions, please call 1-800-222-5381.

WARNING: Read carefully and understand all INSTRUCTIONS before operating. Failure to follow the safety rules and other basic safety precautions may result in serious personal injury. Save these instructions in a safe place and on hand so that they can be read when required. Keep these instructions to assist in future servicing.

TECHNICAL SPECIFICATIONS

ITEM	DESCRIPTION
Tires	4.80-12 Tubeless
Over Length:	77 1/4"L x 40 1/4"W
Ball/Coupler Size	1-7/8 Inch
Load Capacity	610 max
GVWR	800 Lbs.

GENERAL SAFETY REGULATIONS

WARNING: Read and understand all instructions. Failure to follow all instructions listed below may result in electric shock, fire and/or serious injury.

WARNING: The warnings, cautions, and instructions discussed in this instruction manual cannot cover all possible conditions or situations that could occur. It must be understood by the operator that common sense and caution are factors that cannot be built into this product, but must be supplied by the operator.

- Keep the work area clean and dry. Damp or wet work areas can result in injury.
- Keep children away from work area. Do not allow children to handle this product.
- Always wear ANSI-approved safety glasses and heavy-duty work gloves during assembly and use. Do not wear loose clothing or jewelry which can get caught in moving parts.
- Check for damaged parts. Before using this product, carefully check that it will operate properly and perform its intended function. Check for damaged parts and any other conditions that may affect the operation of this product. Replace damaged or worn parts immediately.
- Do not overreach. Keep proper footing and balance at all times to prevent tripping, falling, back injury, etc.
- DO NOT use this trailer when tired or distracted.
- Industrial applications must follow OSHA requirements.

SPECIFIC OPERATION WARNINGS

- Before each use, always examine the trailer for proper tire condition and air pressure, damaged Tail Lights, damaged Side Running Lights, loose bolts and nuts, structural cracks, bends and any other condition that may affect its safe operation. Do not use the Trailer even if minor damage appears.
- Before each use, always attach the Safety Chains of the trailer to the towing vehicle. Make sure the Safety Chains are attached to the towing vehicle with the equal length at each side. Do not allow the Safety Chains to drag on the ground.
- Always check to make sure the payload being transported properly and safely secured in the trailer. Load the Trailer evenly from side to side with 60% of the load forward of the Axle.
- Make sure the towing vehicle is capable of towing this trailer and its payload. Make sure the hitch on the towing vehicle is capable of towing the Trailer and its payload. The towing capacity of the hitch is typically stamped on the hitch drawbar.
- Make sure the hitch coupler and the vehicle's Ball Hitch (not included) are of equal mating size (1-7/8in.) and are rated equal to or greater than the weight of the trailer and its payload.
- Do not exceed 45 miles per hour when towing the trailer. Excess speed is a major cause of vehicle-trailer accidents.
- The Tail Light Bulbs supplied with this trailer are for a 12 Volt DC electrical system only. Do not attempt to power the Light Bulbs with any other type or voltage electrical current.
- Whenever possible, park the trailers on a flat, level, paved surface and chock both tires to keep the trailer from accidentally moving.
- Before attempting to fold up the trailer, make sure it is on a flat, level, solid surface and chock both tires.
- Never attempt to fold up the trailer without assistance.
- DO NOT exceed the 610 pound weight capacity.
- DO NOT allow anyone to ride in the towed vehicle or on the trailer.
- The coupler must be properly secured to the hitch ball. After assembly and attachment, pull up and down on the hitch coupler to make sure the hitch ball is snug in the hitch coupler. If the coupler is not secured properly, it could come loose while the trailer is in motion, causing property damage, serious personal injury or even death.
- Make wide turns when towing a loaded trailer, avoiding both sharp turns and U-turns. Turning too sharply can cause damage to the trailer and/or the tow vehicle.

UNPACKING

When unpacking, check to make sure all the parts shown on the Parts List are included. If any parts are missing or broken, please call the distributor at 1-800-222-5381.

TRAILER ASSEMBLY INSTRUCTIONS

STEP 1:

Lay out two side rail (#2R,2L), towbar (#1), front cross member (#4, shorter), rear cross member (#6, longer) and two connecting plate (#11) by using M10*95 bolt, \varnothing 10 flat washer and M10 nylon lock nut (#W,O,H) as shown; Do not tighten nylon nut until all bolts are positioned in place.

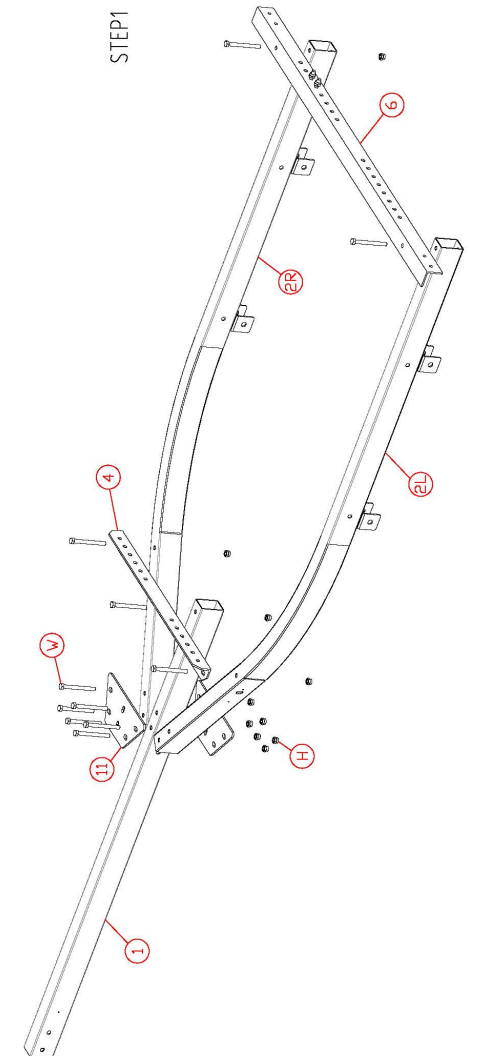

STEP 2:

2.1 Turn the trailer assembly upside down. With spring (#20) eyes toward the front, slide spring into front and rear spring hanger, secure with M14*80 bolt and M14 nylon lock nut (#G, K). Place axle (#5) on spring (#20) with hex "button" on center of each spring in the corresponding hole near the right and left ends of the axle. Place M10*55*85 "U" bolt (#30C) on left and right of each spring, passing through spring plate(#14). Secure each spring plate with \varnothing 10 spring washer (#N) and M10 nylon lock nut (#H) .

2.2 Locate both tire/hub (#18,25) assemblies to axle (#5) by sliding hub (wheel studs pointed outward) over spindle. Slide outer bearing (#26) on to spindle and into bearing cap in hub (#25) . Secure hub with spindle washer (#P) and castle nut (#M), tighten them snugly. Note: Back off castle nut (#M) slightly a little bit, so that hub can spin freely.

Insert cotter pin (#Q) through the hole at the end of axle and bend pin over to lock .

G

STEP2

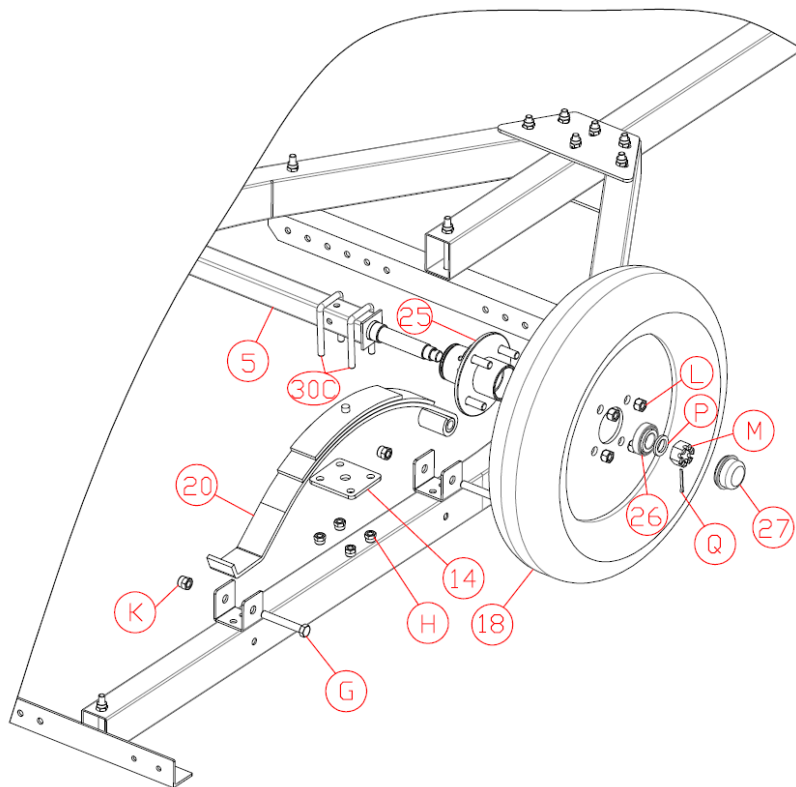

STEP 3:

Turn over the trailer assembly to make two tire touch ground. Install coupler (#24) to tow bar (#1) with M10 x 75 bolts, \varnothing 10 flat washer and M10 nylon lock nuts (#V, O, H). The rear M10 x 75 bolt (#V) goes through center link of safety chain (#23).

Note: Make sure safety chain is the same length for each side .

Insert coupler safety pin (#Y) to coupler and lock with 2mm R pin (#U) when lock your trailer .

STEP3

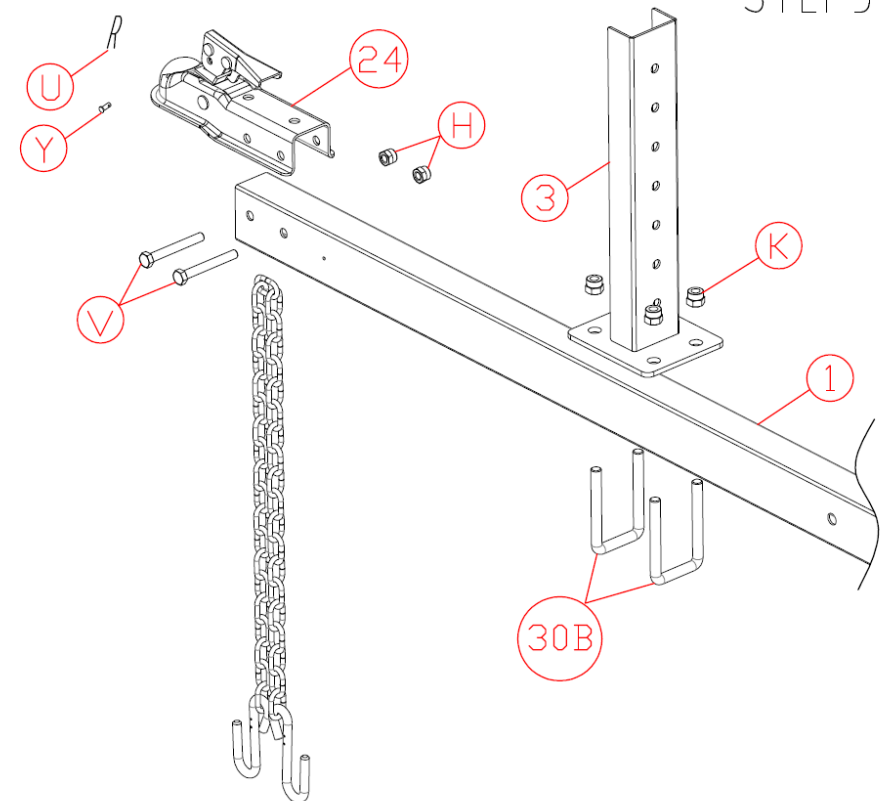

STEP 4:

Install lower orientation bar (#3) passing M10*65*95 U bolt (#30B) through under of tow bar with \varnothing 10 spring washer (#N) and M10 nut (#I). (The positing of orientation bar depends on the length of your watercraft).

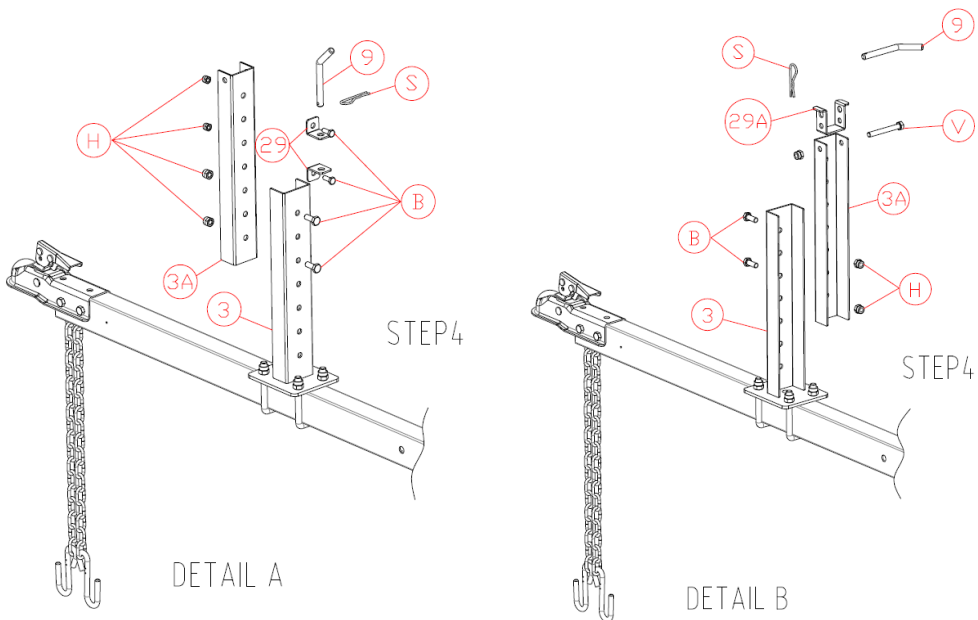

STEP 5:

Connect the upper orientation bar(#3A) using M8*30bolt with M8 spring washer and M8nut(#D,E,X) through the lower orientation bar(#3). Attach bow stop(#29) to the upper orientation bar(#3A) with M8*30 bolt, M8 spring washer and M8 nut(#D,E,X) (The position of bow stop depends on the height of your watercraft). Insert L latch (#9) to the upper bow stop with 3mm R pin(#S) to lock your watercraft. SEE DETAIL A.

If there are no hole in front bow of watercraft to hold it , it will be a holder under the bow of watercraft: Install lower orientation bar(#3) passing M10*65*95Ubolt(#30B) through under of towbar with \varnothing 10spring washer(#N) and M10nut(#I) (The position orientation bar depends on the length of your watercraft). Connect the upper orientation bar(#3A) using M8*30bolt with M8spring washer and M8nut(#D,E,X) through the lower orientation bar(#3). (The position of upper orientation bar depends on the holder height of watercraft.) Attach bowstop(#29A) into the upper orientation bar(#3A), with M10x75bolts, \varnothing 10 spring washer and M10 nylon locknuts(#V,O,H). Then connect bowstop(#29A) with holder of watercraft using "L" latch(#9) through upper hole of bowstop then lock your watercraft with 3mm R cotterpin(#S). SEE DETAIL B.

STEP 6:

Attach rear bunk support (#7 longer) to rear cross member (#6) using M10*25 bolt, \varnothing 10 flat washer and M10 nylon lock nut (#B, O, H). The position of rear bunk support depends on the bottom width of your watercraft. Do the same way with front bunk support (#7A shorter) to front cross member (#4) as shown.

Attach bunk (#15) to the rear and front bunk support (#7 & 7A) using M10*30 bolt with \varnothing 10 flat washer and M10 nylon lock nut (#A, O, H).

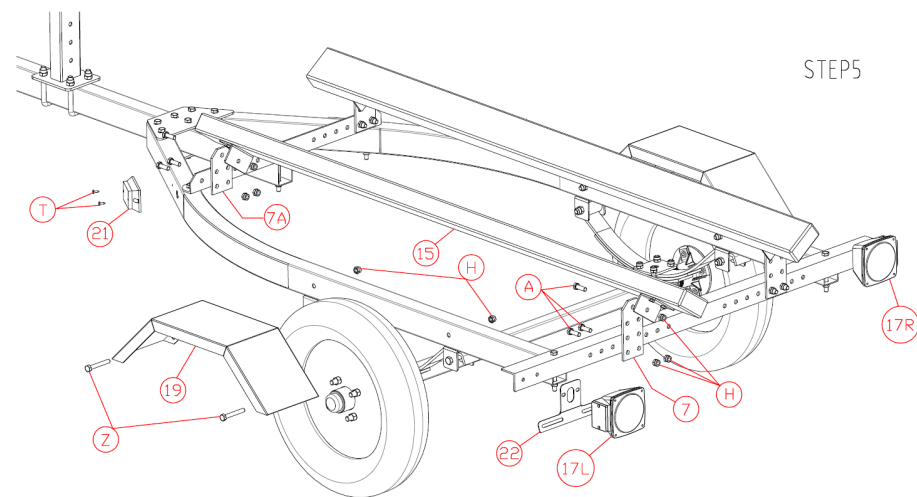

STEP 7:

Attach two fender (#19) to side rails (#2R, 2L) with M10*70 bolt, \varnothing 10 flat washer and M10 nylon lock nut (#Z, O, H).

STEP 9:

Open the lens of side running light (#21). Secure each side running light (#21) to side rail (#2R, 2L) with Self tapping screw (#T). Attached left tail light (#17L) (which has a clear window for the license plate light) with license bracket (#22) to left of cross member (#6) with provided washer and nut. Next install right tail light (#17R) using provided washer and nut.

Tighten the M12 HUB LUG NUT (M) with socket or lug wrench to 90 ft/lbs (**Very tight**) . Caution: Periodically grease the seal on the backside of each Wheel Hub .

TRAILER LIGHT AND WIRE ASSEMBLY INSTRUCTIONS

WIRING DIAGRAM AND INSTRUCTION

1. Check alignment of all parts and install the 4-wire vehicle connector in the trunk area of your car.
2. Locate the connector plug near the hitch ball and lay out wires.
3. Connect the white wire to the frame or body of the car;
4. Connect the brown wire to the tail light by stripping, wrapping, and taping connector; similarly connect the yellow wire to the left signal and stop light wire and the green wire to the right signal and stop light wire.

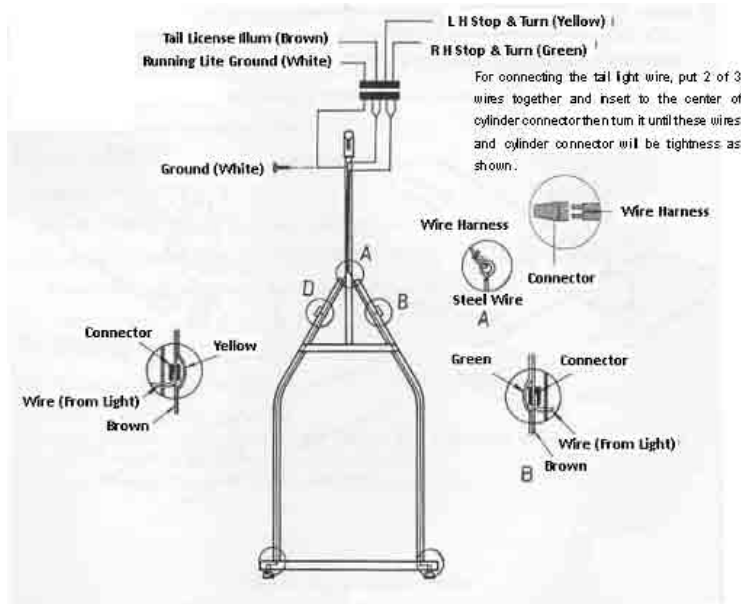

NOTE: Some foreign vehicles may require an adapter to convert their 5-wire system to the wire vehicle connector.

1. Attach white ground wire at plug end of wiring harness to the small hole in front bottom of towbar with 4mm tapping screw.
2. Leave about 18" of wire beyond the coupler and insert steel wire to front of side rail in towbar hole to the front of towbar, tie with wire harness as shown figure A and pull it out, then from this joint, split the yellow/brown wire and green/brown wire. Make yellow/brown go through side rail to left running light, make green/brown wire go to the right running light.
3. Connect the wire lead from the side running light to the brown wire on each side with the wire connector as shown figure B, D. Use pliers to squeeze the connector closed.
4. Lay out wire along with each side rail to tail light. Cut yellow / brown and green / brown wires to appropriate length and strip ends of wire 3/4".
5. Make tail light connections as per color code as shown:

Left Side	Right Side
Yellow – Yellow wire	Green – Green wire
Brown – Brown wire	Brown – Brown wire

SAFE USE AND OPERATION RULES

1. TOWING VEHICLE

- Make sure vehicle is capable of towing the load.
- Excess speed is the second highest cause of car-trailer accidents. Recommended maximum speed for all passenger cars towing trailers is 45 MPH.

2. HITCH, BALL, COUPLER

- Check that the hitch on the towing vehicle is capable of towing the trailer. The towing capability of the hitch is normally stamped on the hitch drawbar.
- Make sure the coupler and the ball are the same sizes and are rated equal to or greater than the load.
- Never attach anything other than the proper size coupler to the ball for towing.
- **CAUTION: Care must be taken when backing up the Trailer; only back up the trailer on a straight path.** If the Trailer is allowed to turn off the straight path while backing up, the Trailer could jackknife, causing severe damage to the trailer and to the towing vehicle.

3. SAFETY CHAINS:

- Be sure to use safety chains.
- Check that the safety chains are attached to towing vehicle with the safety chains the same length for each side.
- Do not allow chains to drag on the ground.

4. LOADING:

- Never overload the trailer. Maximum load is 610LBS.
- Load trailer evenly from side to side with 60% of the load forward to the axle. It is important that the tongue be pressing down on the hitch, but not exceeding a downward force of 610 lbs.
- Reduce weight in car trunk and rear seat areas by amount of tongue weight of your trailer.
- It is against the law to carry passengers in any trailer.

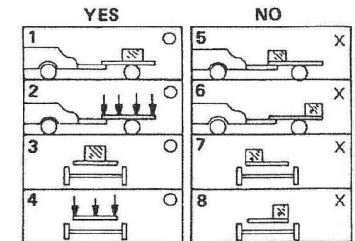

5. LIGHTING:

- Check lighting before each use and every 100 miles to be sure the stop, tail, and turn signals are working properly. REPLACE ANY BROKEN LENSES, REFLECTORS, OR BULBS.
- Check wires for good connections and possible fraying or wearing of insulation.
- Bulbs supplied with this trailer are for 12-volt systems.
- Bulbs used in tail light are: Number – 1157 – Stop and Tail.
- Bulb for clearance is: Number – 194.

6. TIRES:

- Check tires for wear and proper inflation before each use and every 100 miles.
- Tire pressure should be kept at 60 PSI.
- Check and tighten lug nuts. Torque to 85-90 FT-LBS.
- Re-torque after first 50 miles.

7. OPERATION:

- Know how to properly control your towing vehicle – trailer combination on the highway under all conditions. Remember the loaded weight of the trailer will increase your braking and stopping distances appreciably.

- When towing a trailer over long distances, stop and check the tightness of all connections, lights, and running gear every 100 miles.
- Carry emergency flares, and fire extinguisher if required for operation in your state.
- It is recommended to carry extra bulbs and fuses if you are towing the trailer at night over any great distance.

8. MAINTENANCE

- Check and maintain the trailer, coupler, ball and hitch before each use and every 200 miles.
- Inspect coupler, hitch and ball for damage before each use.
- Ball or hitch can be damaged in parking, hitting curbs, dragging when crossing ditches or railroad tracks.
- Check safety chains and hooks for wear and do not allow safety chains to drag on ground.
- To prevent bearing damage, disassemble and repack wheel bearing with a good grade of wheel bearing grease every 2000-3000 miles or yearly.
- If you do not know how to repack wheel bearing, take your trailer to a qualified technician.

SPECIAL NOTICE FOR COUPLER

1. Only use a 1 7/8" ball hitch (not included) on the towing vehicle.
2. Temporarily remove the "R" Pin and Safety Pin. Then, pull up on the Trigger and lift up on the Handle.
3. **NOTE:** To reduce friction between the hitch ball and Coupler, apply a layer of heavy weight grease over the hitch ball.
4. With assistance, place the Coupler over the vehicle's hitch ball and pull back on the Trigger and push down on the Handle until the Trigger locks in the slot. Pull up and down on the Coupler to make sure the hitch ball is fitting snugly in the Coupler. There should be no play between the hitch ball and Coupler.

IMPORTANT: If there is play, tighten the Adjustment Nut until no play is present – after unlocking the handle, the Nut retaining plate (holding the adjusting nut in place) needs to be pressed back while the nut is tightened. After Nut is tightened, the retaining plate needs to be fit in place against the flats of the Nut to prevent it from moving. This adjustment should be done by two people. If the Adjustment nut is too tight, the Handle will not lock.

After the Adjustment Nut is properly adjusted, pull back on the Trigger and push down on the Handle until the Trigger locks in the slot. Pull up on the Handle firmly to make sure the Trigger is locked in place and the Handle cannot move. Replace the Safety Pin and the "R" Pin.

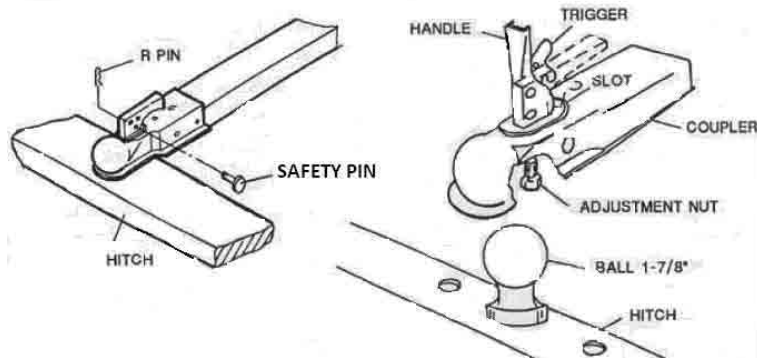

IMPORTANT

The purpose of the following notices is to give you tips on safe use and operation of your utility trailer.

1. Please read the instructions carefully and follow them step-by-step for easy assembly. Please keep this instruction.
2. Please double check the assembling step-by-step to be sure each is followed.
3. Before using, please inspect your trailer.
4. Do not remove the VIN sticker from the tow bar.

NOTICE:

- Re-fill grease on bearing after every 3,000 miles of use.
- Keep tire pressure at 60 PSI, cold.
- Please insure that you comply with the following before using your trailer:
 1. Tighten U-bolt.
 2. Tighten lug nuts.
 3. Tighten trigger lock on coupler.
 4. Hook up safety chain.
 5. Trailer load should not exceed its 610 LB capacity and should be properly secured.
 6. Trailer load size should not exceed trailer's bed board size.

TRAILER LICENSING NOTICE:

Some states may consider that this trailer kit is and specially constructed or a homemade vehicle for registration, licensing and/or titling purposes.

The M.C.O. (Manufacturer's Certificate of Origin) supplied with your trailer must be filled out and signed by the dealer transferring ownership to you.

When licensing your trailer, you will need the signed M.C.O., a purchase invoice, cash register receipt, or bill of sale showing the purchase and retail sales tax or use tax collection by the retailer. Take these to your local Department of Motor Vehicles and upon payment of the appropriate State fees, you will be issued a title, registration and license plate (if required). Some states will require inspection of the assembled and finished trailer kit before issuing a title registration/license.

If you require additional information or guidance on licensing or titling, please consult your State Department of Motor Vehicles.

DIAGRAMS AND PARTS LIST

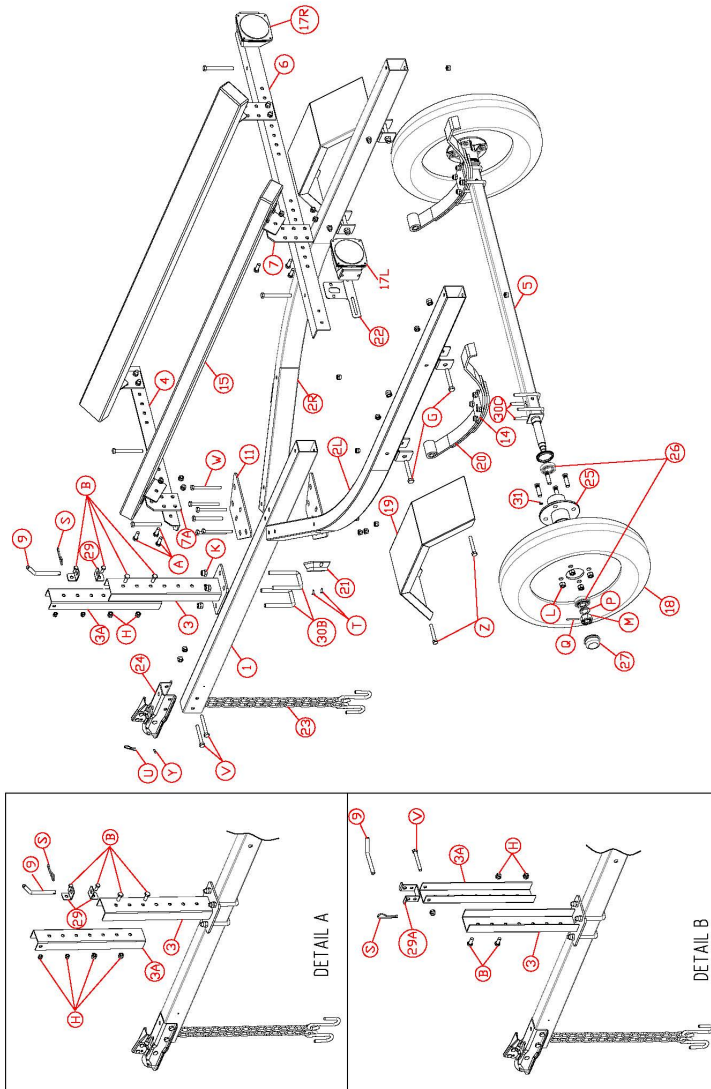

PARTS LIST

Part No.	Description	Qty.	Part No.	Description	Qty.
1	TOW BAR	1	A	M10×30 BOLT	12
2R	RIGHT SIDE RALL	1	B	M10×25 BOLT	4
2L	LEFT SIDE RALL	1	C	M12×80 BOLT	4
3	LOWER ORIENTATION BAR	1	H	M10 NYLON LOCK NUT	42
3A	UPPER ORIENTATION BAR	1	K	M12 NYLON LOCK NUT	8
4	FRONT CROSS MEMBER	1	L	M12 HUB LUG NUT	8
5	AXLE	1	M	CASTLE NUT	2
6	REAR CROSS MEMBER	1	P	SPINDLE WASHER	2
7	REAR BUNK SUPPORT (LONGER)	2	Q	COTTER PIN	2
7A	FRON BUNK SUPPORT (SHORTER)	2	S	3MM R PIN	1
9	∅ 12 L LATCH	1	T	SELF TAPPING SCREW	5
11	CONNECTING PLATE	2	U	2MM R PIN	1
14	SPRING PLATE	2	V	M10×75 BOLT	3
15	BUNK	2	W	M10×100 BOLT	11
17L	LEFT REAR LIHGT	1	Y	COUPLER SAFETY PIN	1
17R	RIGHT REAR LIHGT	1	Z	M10×70 BOLT	4
18	TIRE/WHEEL ASSY	2			
19	FENDER	2			
20	SPRING	2			
21	SIDE RUNNING LIGHT	2			
22	LICENSE PLATE HOLDER	1			
23	SAFETY CHAIN	1			
24	COUPLER	1			
25	HUB SET	2			
26	BEARING	4			
27	DUST CAP	2			
29	BOW STOP	2			
29A	BOW STOP	1			
30B	U BOLT (M12×65×100)	2			
30C	U BOLT (M10×52×85)	4			
31	GREASE FITTING	2			

Note: Some parts and hardware are listed for illustration purposes only, and are not available individually as replacement parts.

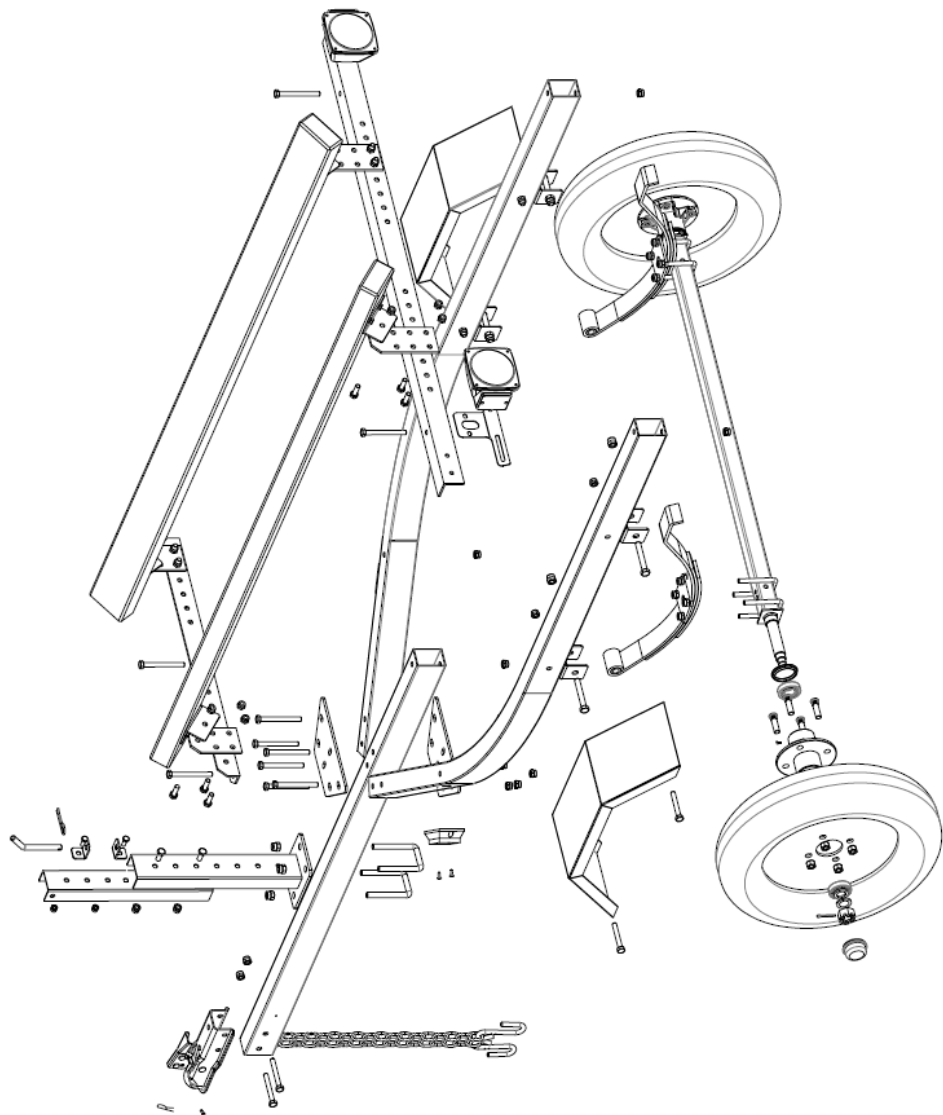

Reporting Safety Defects

If you believe that your vehicle has a defect which could cause a crash or could cause injury or death, you should immediately inform the National Highway Traffic Safety Administration (NHTSA) in addition to notifying the distributor.

If NHTSA receives similar complaints, it may open an investigation, and if it finds that a safety defect exists in a group of vehicles, it may order a recall and remedy campaign. However, NHTSA cannot become involved in individual problems between you, your dealer, or Northern Tool & Equipment Company, Inc.

To contact NHTSA, you may call the Vehicle Safety Hotline toll-free at 1-888-327-4236 (TTY: 1-800-424-9153); go to <http://www.safercar.gov>; or write to:

Administrator, NHTSA
1200 New Jersey Avenue SE.
Washington, DC 20590.

You can also obtain other information about motor vehicle safety from <http://www.safercar.gov>

WARRANTY

One-Year Limited Warranty

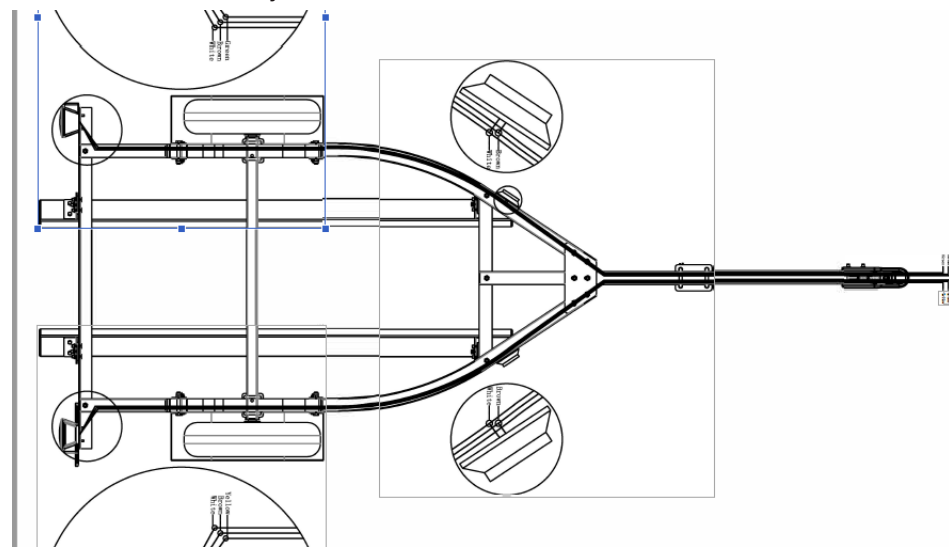

ULTRA-TOW

Distributed by
Northern Tool + Equipment Co., Inc.
Burnsville, MN 55306
NorthernTool.com
Made in China