

OWNER'S MANUAL

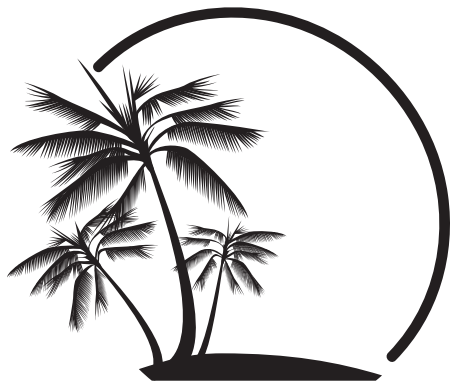

BEST OF TIMES™



SAFETY INFORMATION

In our continuing effort to ensure that your experience with Best of Times™ furniture is positive with regard to comfort, quality and design, and also with regard to safety, please note the following important safety information, in addition to other safety information noted in this booklet.

SAFETY WARNING! Use of furniture needing care and maintenance, or use of damaged furniture, can result in injury. Also, minor repair issues can become major repair and service issues, and create potential safety issues.

Contact your local Best of Times™ Dealer or Sales Representative for support.

Product Inspection

Periodically and carefully inspect all Best of Times™ products for breakage and /or indications of wear. Inspections must include, but not be limited to, the weld areas of product frame, seats and legs. If any cracks should appear on the product or at welds, the item must immediately be removed from service until repaired.

Inspections must include all bolts (on seating pieces, bar, tables, umbrellas, etc.). Should any loose or missing hardware be detected, the item must be removed from service immediately until the hardware can be properly tightened and/or replaced.

To obtain replacement parts, please contact your local Best of Times™ Dealer or Sales Representative.

Umbrellas

Windy Conditions

SAFETY WARNING! All Best of Times™ umbrellas must always be closed and taken down in windy conditions.

When Not In Use

All Best of Times™ umbrellas should always be closed when not in use.

Stools and Chairs

Best of Times™ stools and chairs are rated for a maximum weight of 200 lbs. Exceeding this weight limit can cause bodily injury.

Please save your receipt so you have a record of Best of Times™ model numbers purchased, as you may wish to add accessories, update your fabric, or expand your collection during your ownership of the Best of Times™ Bar!

Regular periodic care of your Best of Times™ Bar will maintain its appearance and functionality better than occasional, heavy duty maintenance. Consider the specific conditions and usage to which your product is exposed so appropriate maintenance is provided.

Mildew can form on dirt or other substances deposited upon the fabric. Regular cleaning of outdoor furniture will help to prevent its forming.

Please read this booklet carefully and in its entirety. Contact your Retail Dealer or Commercial Representative if you have additional questions.

Safety Information	2
Product Inspection	2
Umbrellas	2
Stools and Chairs	2
Package Contents	4
Assembly Instructions.	6
Assembling the Bar	6
Assembling the Grill Table	12
Cleaning and Care	13
Frames	13
Painted Finishes	13
Table Tops	13
Faux Leather	13
Fabric	13
Umbrellas.	14
Helpful Hints	15
More Information	15

PACKAGE CONTENTS

Owner's Manual



Bar Frame

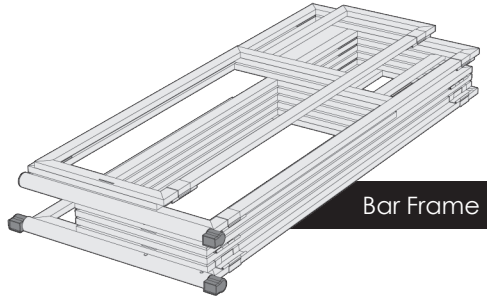

Top Right Shelf

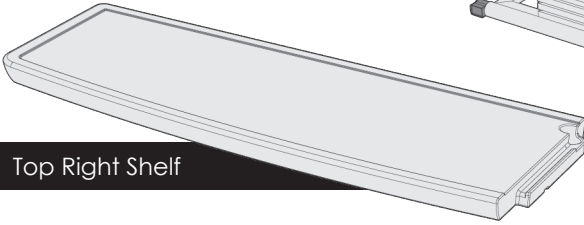

Top Left Shelf

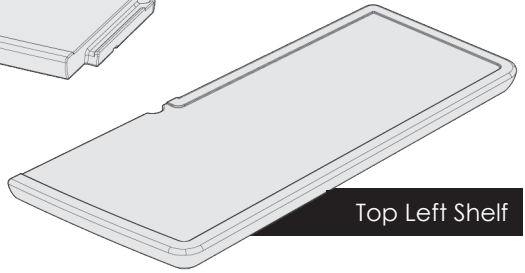

Middle Right Shelf

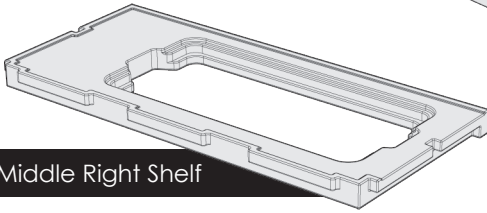

Middle Left Shelf

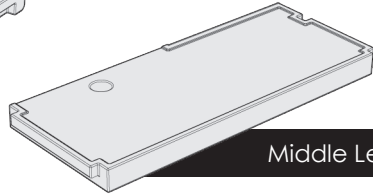

Bottom Right Shelf

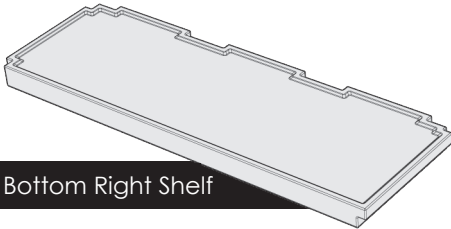

Bottom Left Shelf

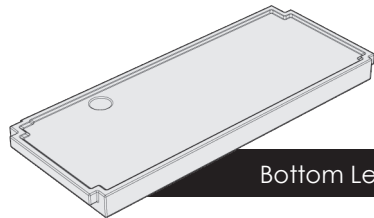

Ice Chest

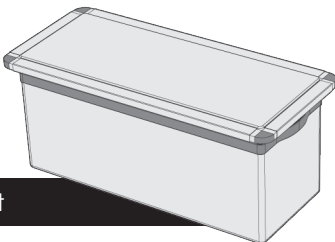

Bar Wrap

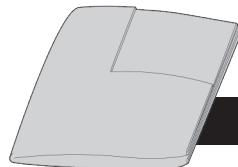

PACKAGE CONTENTS

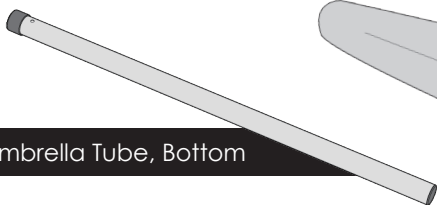

Umbrella Tube, Bottom

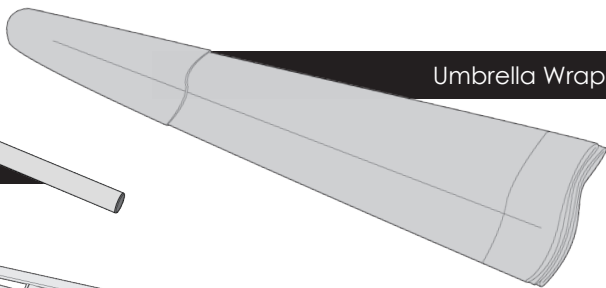

Umbrella Wrap

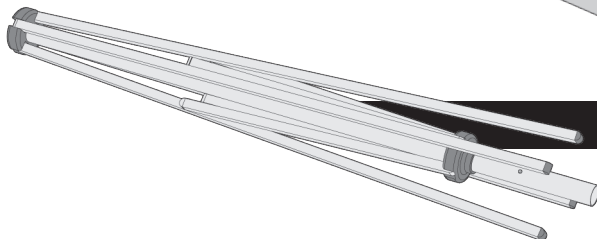

Umbrella, Top

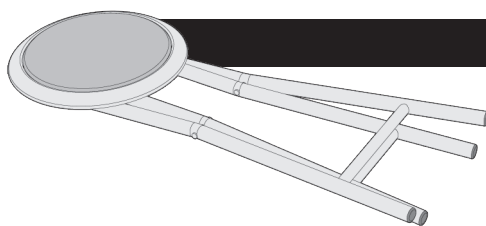

Stool (x4)

Grill Table *(available as an accessory)*

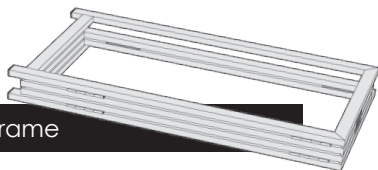

Grill Table Frame

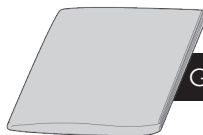

Grill Table Wrap

Grill Table Bottom Shelf

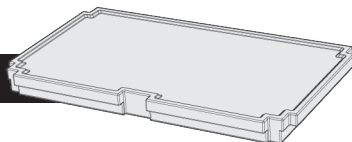

Grill Table Top Shelf

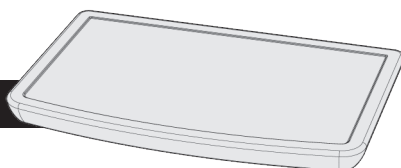

ASSEMBLY INSTRUCTIONS

Assembling the Bar

The following illustrations show step by step instructions for assembling the Bar and Grill Table. Contact your Retail Dealer or Commercial Representative if you have any questions.

1. Line up Bar Frame as shown

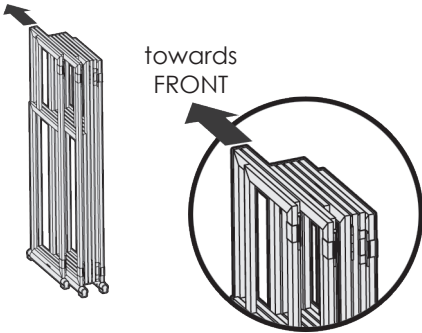

2. Extend the frame to the left.

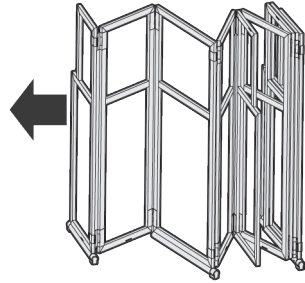

3. Rotate the end panel around 180°.

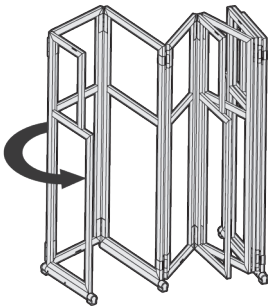

4. Rotate the 3rd panel 90° as shown.

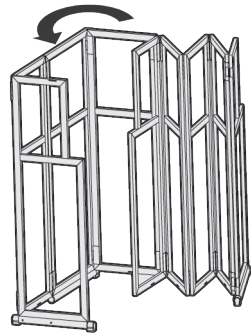

5. Extend and unfold the remaining panels to the right.

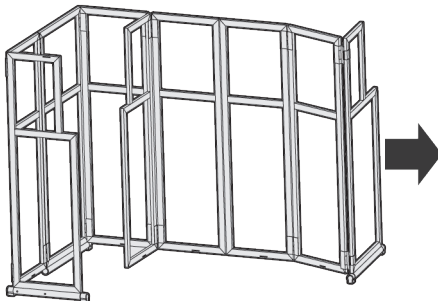

ASSEMBLY INSTRUCTIONS

6. Rotate the end panel around 180°.

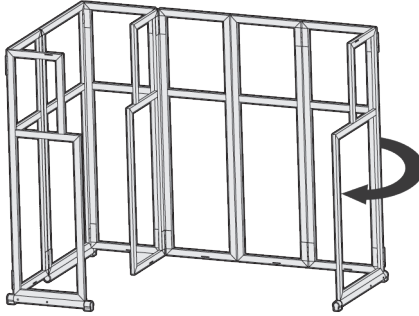

7. Install the Bottom Shelf, Left.

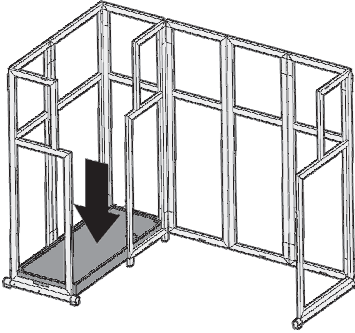

8. Install the Bottom Shelf, Right.

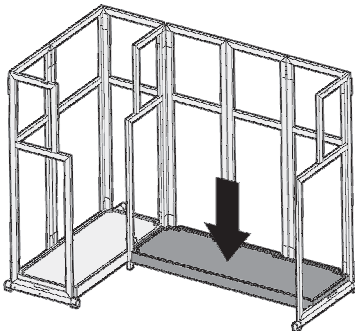

ASSEMBLY INSTRUCTIONS

9. Install the Middle Shelf, Left.

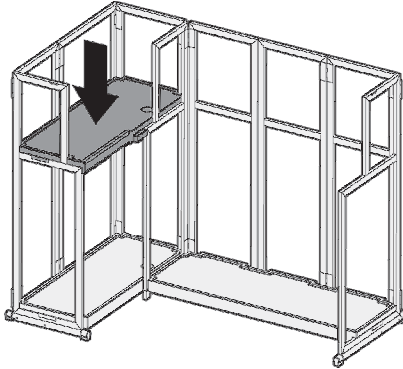

10. Install the Middle shelf, Right.

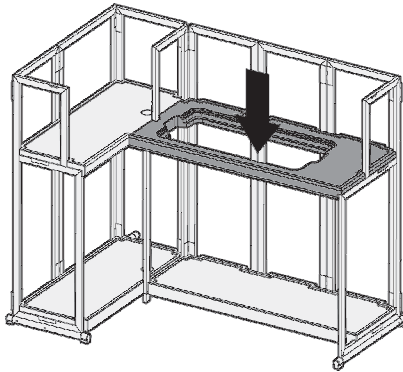

11. Install the Top Shelf, Right.

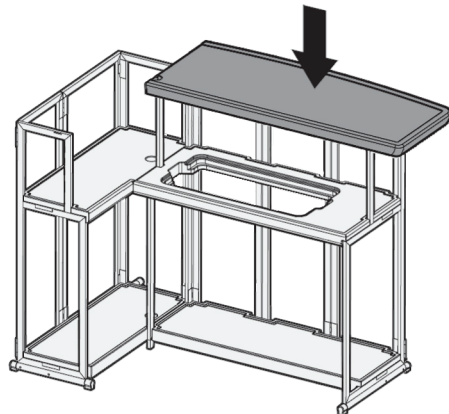

ASSEMBLY INSTRUCTIONS

12. Install the Top Shelf, Left.

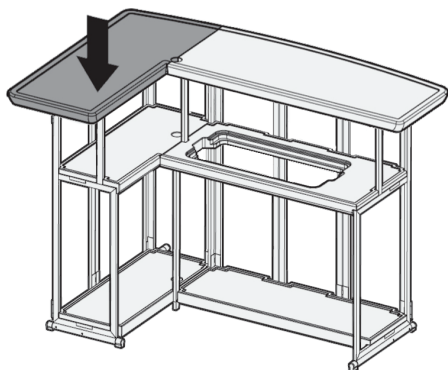

13. Rotate the locking levers (x3) on the underside of the Top Shelves.

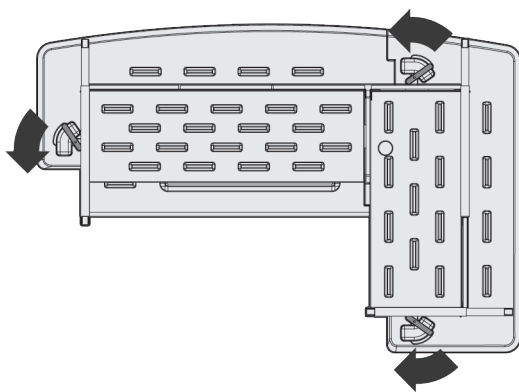

14. Apply the Bar Wrap using the Velcro attachments.

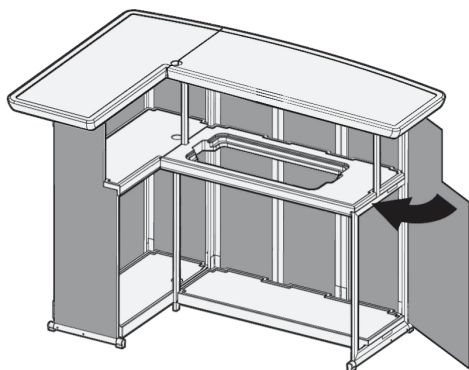

ASSEMBLY INSTRUCTIONS

15. Install the Ice Chest into the hole in the Middle Shelf, Right.

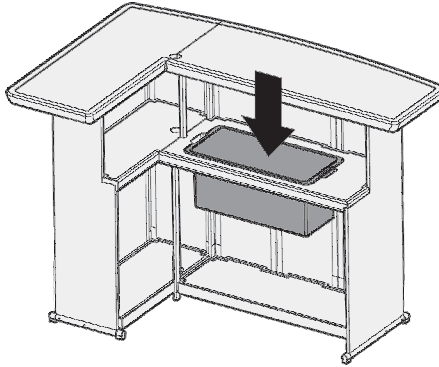

16. Install the Umbrella through the holes in the Top, Middle, and Bottom Shelves.

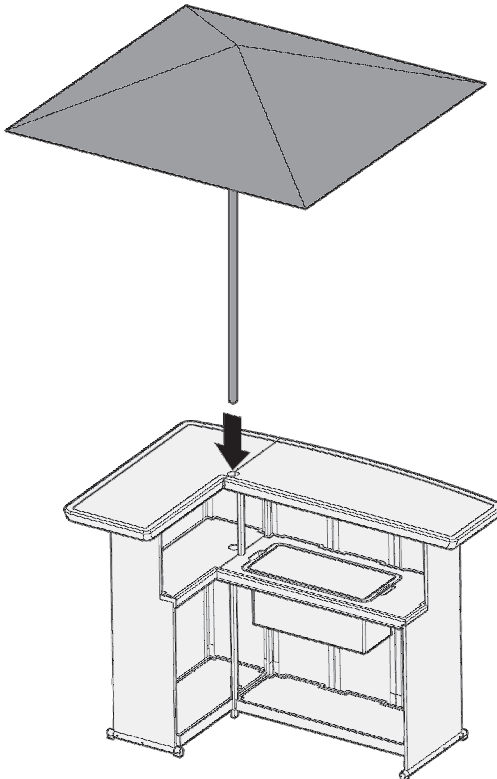

ASSEMBLY INSTRUCTIONS

Assembling the Grill Table *(available as an accessory)*

The following illustrations show step by step instructions for assembling the Grill Table. Contact your Retail Dealer or Commercial Representative if you have any questions.

1. Unfold the Grill Table Frame.

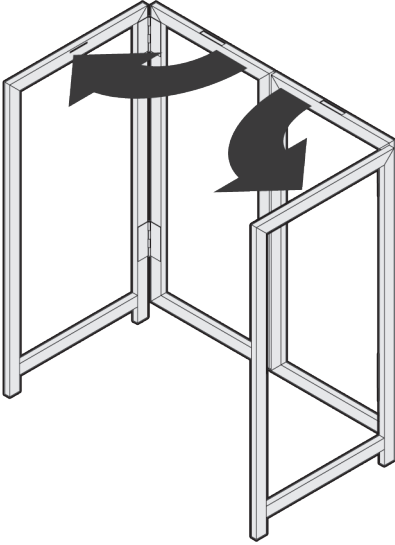

2. Install the Grill Table Bottom Shelf.

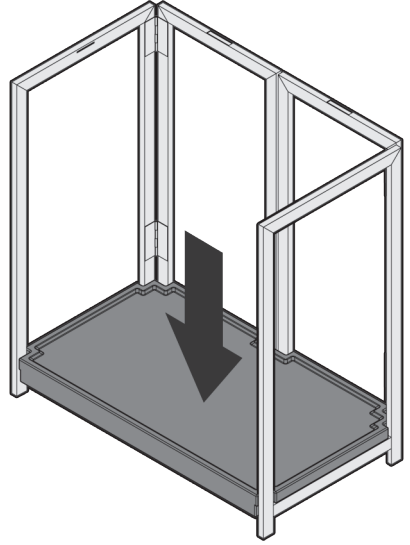

3. Install the Grill Table Top Shelf.

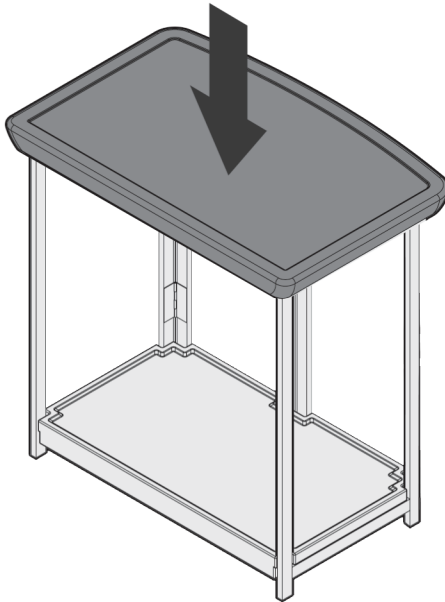

ASSEMBLY INSTRUCTIONS

4. Rotate the locking levers (x2) on the underside of the Grill Table Top Shelf.

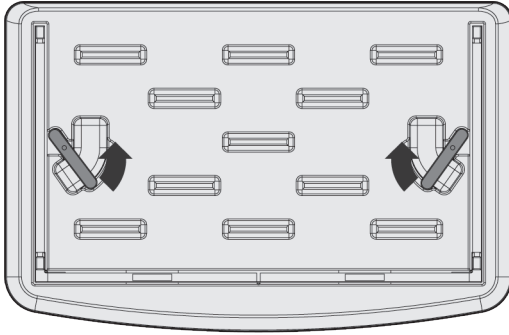

5. Apply the Grill Table Wrap using the Velcro attachments.

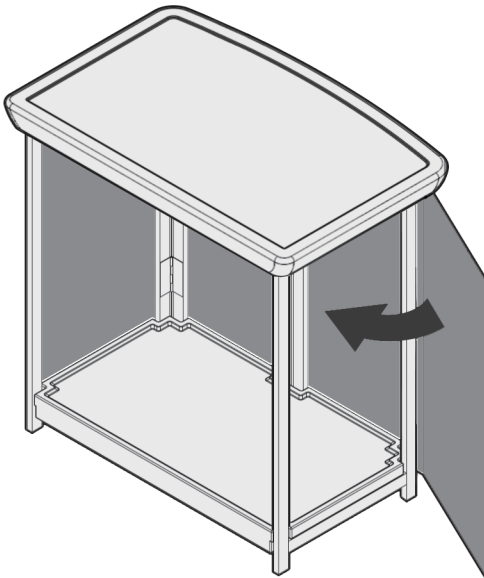

CLEANING AND CARE

Regular periodic care of your Best of Times™ furniture will maintain its appearance and functionality better than occasional, heavy duty maintenance. Consider the specific conditions and usage to which your product is exposed so appropriate maintenance is provided.

Frames

Regularly tighten all hardware to avoid loosening which can lead to bolt failure and product breakage. Replace missing hardware (remove product from service until repaired).

Painted Finishes

Painted finishes are used on aluminum and steel seating, frames and umbrellas. Periodically clean the finish with a sponge or soft bristle brush using a cleaning solution with 1/4 cup (2 oz.) mild liquid soap in a gallon of lukewarm water (100° F / 38° C). Rinse thoroughly. Avoid using abrasive cleaners. For gloss finishes, we recommend periodic waxing of the frame with a high grade automotive paste wax or the use of a commercially available protectant to help maintain and/or restore the luster of the finish. Protectants can be purchased at most casual furniture retailers.

Caution: In seaside use, salt can accumulate on the finish, leading to finish failure. In indoor pool areas, chlorides can accumulate on the finish, leading to finish failure. In both of these environments, repeated cycles of condensation followed by evaporation cause build-up of these aggressive corrosives. Regular cleaning with mild soap and water, per the above instructions, will remove the concentrated deposits and protect the furniture finish.

Table Tops

Avoid build-up of grease and stains by washing regularly with a nonabrasive sponge or soft bristle brush with a cleaning solution with 1/4 cup (2 oz.) mild liquid soap in a gallon of lukewarm water (100° F / 38°C). To release embedded dirt, use a vinegar and water solution (equal parts each). Rinse thoroughly with clean water.

Faux Leather

Clean all spills promptly. For a quick, easy clean up - use baby wipes. For general cleaning, see the instructions in the FABRIC section.

Fabric

The life of your patio furniture fabric largely depends on its care. Clean all spills promptly. Fabric life can be extended by simply rinsing down the patio furniture regularly with water. Certain suntan and sun block products may permanently discolor any fabric. This possibility can be minimized by immediately cleaning after contact. In addition, storing the wraps and umbrella when not in use will extend fabric life.

CLEANING AND CARE

Prepare a cleaning solution with 1/4 cup (2 oz.) mild liquid soap in a gallon of lukewarm water (no warmer than 100° F / 38° C). Clean fabric with the solution using a sponge or soft bristle brush. Rinse thoroughly with clean water. Allow to air dry.

Caution: Certain suntan and sun block products contain "PABA". PABA is harmful to fabric and can permanently discolor it; therefore, contact with fabric should be avoided. If contact is made, cleaning the fabric immediately with a non-abrasive, mild soap and water solution followed by a fresh water rinse may minimize the possibility of discoloration.

- *Do not use a bleach solution unless specifically listed as a cleaning agent for the specific fabric, such as for solution dyed acrylics.*
- *Do not submerge or allow fabric to lie in standing water.*
- *Do not put fabric into the dryer.*
- *Do not use harsh detergents or stiff bristle brushes.*
- *Do not use Pine Oil cleaners or abrasive household cleaners.*
- *Do not use heat or hot water.*

Mildew may form on dirt or other substances deposited upon the fabric. Regular cleaning of the furniture will help to prevent its forming. If mildew does develop, add 1 cup bleach to the cleaning solution. Apply to the affected area and allow to soak in. Scrub with a soft bristle brush, then rinse thoroughly. Repeat if necessary. For stubborn mildew stains, use a household mildew remover - test in an inconspicuous location first.

FOLLOW THE MANUFACTURER'S INSTRUCTIONS.

Umbrellas

Always close umbrellas when not in use. All Best of Times™ umbrellas must always be closed and removed from service in windy conditions to protect umbrellas against damage from inclement weather, and to protect persons from potential injury due to umbrellas toppling or moving in such conditions. If umbrellas become wet, open for a complete airing and make certain they are thoroughly dry before closing.

Occasional lubrication of the moving parts of the umbrella with a silicon lubricant spray is recommended.

Caution: Do NOT get lubricant on fabric or finish.

Fabric

Follow the instructions in the FABRIC CLEANING AND CARE section.

Painted Finish

Care for the finish as noted in the PAINTED FINISHES CLEANING AND CARE section.

HELPFUL HINTS

Please save your receipt so you have a record of Best of Times™ model numbers purchased, as you may wish to add accessories, update your fabric, or expand your collection during your ownership of Best of Times™ furniture! Your sales receipt will be required to review any warranty claim.

Regular periodic care of your Best of Times™ Bar will maintain its appearance and functionality better than occasional, heavy duty maintenance. Consider the specific conditions and usage to which your product is exposed so appropriate maintenance is provided.

Mildew can form on dirt or other substances deposited upon the fabric. Regular cleaning of outdoor furniture will help to prevent its forming.

Please read this booklet carefully and in its entirety. Contact your Retail Dealer or Commercial Representative if you have additional questions.

Best Of Times LLC
34145 Pacific Coast Hwy #632
Dana Point, CA 92629

For Customer service call toll free:
800-997-6762