



## 9000-Lb. 12 Volt DC Electric Truck Winch

Owner's Manual



**⚠ WARNING:** Read carefully and understand all ASSEMBLY AND OPERATION INSTRUCTIONS before operating. Failure to follow the safety rules and other basic safety precautions may result in serious personal injury.

Item #54125

**SAVE THESE INSTRUCTIONS**

Thank you very much for choosing an Ironton™ product!

For future reference, please complete the owner's record below:

Serial Number/Lot Date Code: \_\_\_\_\_

Purchase Date: \_\_\_\_\_

Save the receipt, warranty, and this manual. It is important that you read the entire manual to become familiar with this product before you begin using it.

This electric winch is designed for certain applications only. Northern Tool & Equipment is not responsible for issues arising from modification or improper use of this product such as an application for which it was not designed. We strongly recommend that this product not be modified and/or used for any application other than that for which it was designed.

For technical questions, please call **1-800-222-5381**.

## Table of Contents



Intended Use.....	4
Technical Specifications .....	4
Important Safety Information .....	5
Specific Operation Warnings .....	6
Assembly Instructions.....	8
Before Each Use.....	10
Operating Instructions.....	10
After Each Use.....	14
Maintenance .....	14
Troubleshooting.....	15
Parts Diagram.....	16
Parts List.....	16
Replacement Parts .....	17
Limited Warranty.....	18

## Intended Use

The Ironton Electric Winch has a cable tensioner to prevent cable tangling. The series-wound motor stays cooler during long pulls while the three-stage planetary gear system provides fast line speed. The automatic load-holding brake provides maximum safety and freespooling for fast line-out with the 12 feet ergonomic handheld remote control.

## Technical Specifications

Property	Specification
Rated Single Line Pull	9,000 lb.
Application	Vehicle Recovery/For Trucks and SUVs
Motor	12V DC 5.5 HP Series Wound
Power In & Power Out	Yes
Duty Cycle Rating	5% (45 sec at Max Rated Load;14 min, 15 sec Rest)
Pendant Controller	Wired, 12ft (3.7m) Long
Gear Train	3-Stage Planetary
Gear Ratio	218:1
Freespool	Sliding Ring Gear
Brake	Auto. Load Holding
Drum (Dia. X L)	2.5" X 8.8" (64mm X 224mm)
Clevis Hook	3/8", Replaceable with Spring-loaded Safety Latch
Fairlead	Roller with Nylon Bushings
Wire Rope Size /Type	3/8" x 65' (6.3mmX19.8m) Nominal Strength=14,000 lb. 7X19 Galvanized Steel Aircraft Wire Rope
Battery	12V DC Minimum 650 CCA
Battery Cables	3.5 Gauge, 6' (1.83m) Long
Mounting Bolt Pattern	10"x 4.5" (254mm x 114.3mm)
Mounting Hardware	Winch: 4xG8, M10-1.50X30mm Fairlead: 2x G8. M12-1.75 X 25mm Solenoid Box: 2x G8. ST-M5 X 14mm
Overload Protection	In Line Circuit Breaker
Sound Rating	85 dB
Overall Dimensions (L X D X H)	20.9" x 6.4" x 8.3"
Weight	81.2 lb. (37 kg)
IP Rating	IP 66 - Winch and Controls (resistant to powerful water jets, except remote control switch)

Layer	Rated Line Pull	Wire Rope Capacity
	9000 lb. (2268kg.)	18.2' (5.5m)
	7350 lb. (1851kg.)	40.6' (12.4m)
	6170 lb. (1566kg.)	65' (19.8m)

First Layer of Wire Rope Performance			
	Line Pull lb. (kg.)	Line Speed fpm (mpm)	Amp Draw (@ 12V)
	0 (0)	19.2 (5.9)	97
	2000 (907)	11.5 (3.5)	146
	4000 (1814)	9 (2.7)	190
	6000 (2722)	7.6 (2.3)	245
	9000 (4802)	5.7 (1.7)	322

## Important Safety Information

### **⚠WARNING**

- Read and understand all instructions. Failure to follow all instructions may result in fire, serious injury and /or DEATH.
- The warnings, cautions, and instructions in this manual cannot cover all possible conditions or situations that could occur. Exercise common sense and caution when using this winch. Always be aware of the environment and ensure that the winch is used in a safe and responsible manner.
- Do not allow persons to operate or assemble the winch until they have read this manual and have developed a thorough understanding of how it works.
- Do not modify this winch in any way. Unauthorized modification may impair the function and/or safety and could affect the life of the winch. There are specific applications for which the winch was designed.
- Use the right tool for the job. DO NOT attempt to force small equipment to do the work of larger industrial equipment. There are certain applications for which this equipment was designed. The tool will be a safer and do the job better at the capacity for which it was intended. DO NOT use this equipment for a purpose for which it was not intended.
- Industrial or commercial applications must follow OSHA requirements.

### **⚠WARNING**

This product may contain chemicals known to the State of California to cause cancer, birth defects or other reproductive harm. Wash hands after handling.

### **⚠WARNING**

#### **WORK AREA SAFETY**

- Inspect the work area before each use. Keep work area clean, dry, free of clutter, and well-lit. Cluttered, wet, or dark work areas can result in injury. Using the winch in confined work areas may put you dangerously close to other cutting tools and rotating parts.
- Keep children and bystanders away from the work area while operating the winch. Do not allow children to handle the winch.

## **⚠WARNING**

### **PERSONAL SAFETY**

- Stay alert, watch what you are doing, and use common sense when operating the winch. Do not use the tool while you are tired or under the influence of drugs, alcohol, or medication. A moment of inattention while operating the tool may result in serious personal injury.
- Dress properly. Do not wear loose clothing, dangling objects, or jewelry. Keep your hair, clothing and gloves away from moving parts. Loose clothes, jewelry, or long hair can be caught in moving parts. Air vents on the tool often cover moving parts and should be avoided.
- Wear the proper personal protective equipment when necessary. Use ANSI Z87.1 compliant safety goggles (not safety glasses) with side shields, or when needed, a face shield. Use a dust mask in dusty work conditions. Also use non-skid safety shoes, hardhat, gloves, dust collection systems, and hearing protection when appropriate. This applies to all persons in the work area.
- Do not overreach. Keep proper footing and balance at all times.

## **⚠CAUTION**

### **WINCH USE AND CARE**

- Inspect before every use, do not use if damaged or parts loose. Examine the winch for structural cracks, bends, damage, frayed or kinked wire rope, and any other conditions that may affect the safe operate of the winch. Do not use the winch even if minor damage appears. A kink permanently weakens the wire rope, even after it is straightened out, kinked wire rope can fail suddenly and must not be used.
- Do not force the product. Products are safer and do a better job when used in the manner for which they are designed. Plan your work, and use the correct product for the job.
- Store the product when it is not in use. Store it in a dry, secure place out of the reach of children. Inspect the tool for good working condition prior to storage and before re-use.
- Use only accessories that are recommended by the manufacturer for use with your product. Accessories that may be suitable for one product may create a risk of injury when used with another tool. Never use an accessory that has a lower operating speed or operating pressure than the tool itself.

## **Specific Operation Warnings**

## **⚠WARNING**

### **GENERAL SAFETY**

- To prevent injury or property damage, read and understand all instructions before operating winch.
- Wear ANSI Z87.1 compliant safety goggles and heavy duty leather work gloves during operation.
- Do not exceed the rated load capacity. Be aware of dynamic loading! Sudden load movement may briefly create excess load causing product failure.

### **INSTALLATION SAFETY**

- Choose a mounting location that can support the winch and rated load capacity.
- Do not weld mounting bolts
- Use supplied power cords and wire rope listed in manual only. Do not use thinner/longer cables or link multiple cables together.
- Keep hands clear of winch rope, hook loop, hook and fairlead opening during installation, operation, and when spooling in or out.
- Wrap the wire rope under 500 lbs. of tension before use. Otherwise, the wire rope may bind during operation.
- Do not route electrical cables near sharp edges or parts that will move or become hot.
- Ventilate area well before and while working on battery. Explosive hydrogen gas can accumulate and explode when ignited by a spark or open flame.
- Only connect to a clean, corrosion free battery.
- Remove all jewelry and metallic objects before working near battery.

### **WINCHING SAFETY**

- Inspect winch rope, hook, and slings before operating winch. Frayed, kinked or damaged winch rope must be replaced immediately. Damaged components must be replaced before operation.
- Do not maintain power to the winch if the motor stalls. Verify the load is within the rated capacity for the wire rope layer. Make sure the battery is fully charged. Use double line rigging whenever possible.
- Do not engage or disengage clutch while under load.
- Always ensure hook latch is closed and not supporting load.
- Never apply load to hook tip or latch. Apply load only to the center of hook.
- Never use a hook whose throat opening has increased, or whose top is bent or twisted.
- Keep clear of fairlead when operating. Do not try to guide wire rope.
- Do not place any fingers through the hook. Fingers may be caught and get pulled into the fairlead or drum. Use the included strap to hold the hook instead.
- Stay out of the direct line that the wire rope is pulling. If it slips or breaks, it will create a whiplash effect. Utilize a winch dampener to help absorb the force released if the wire rope breaks.
- Do not use for overhead hoisting. This winch is intended to be used for pulling only.
- Use a spotter to assist you in ensuring that it is safe to operate the winch. Make sure the spotter is out of the way of the vehicle and the wire rope before activating the winch.
- Do not use the hand crank, if equipped, to assist the winch.
- Do not use vehicle to pull on the wire rope and “assist” the winch.
- Do not use to transport people or animals.
- Disconnect battery cables before working near the wire rope, drum, fairlead or load, to prevent accidental starting.
- Keep wire rope straight to avoid kinking the wire rope.
- Keep children and bystanders away while operating.
- Hook onto the object using a pulling point, tow strap or chain. Do not wrap the wire rope around the object and hook onto the wire rope itself.
- Do not use a recovery strap while winching.

- Secure the load after moving. Do not lock the mechanism.
- Keep at least 5 full turns of wire rope on the drum.
- Keep clear of the wire rope, hook, and load while winching. Do not step over the wire rope. Do not push sideways against the wire rope under tension; wire rope might break under this load and recoil back, striking the person pushing against it or a bystander.
- If the wire rope begins to get entangled, stop the winch immediately and release the wire rope using the switch.
- Only winch with the winching vehicle's transmission placed in neutral. Winching with a vehicle's transmission in gear or park may damage the transmission. A vehicle's transmission is not designed to handle this type of load.
- Do not operate the winch on extreme slopes. Do not exceed the angles for a roller fairlead. For a hawse fairlead, the angle should be as close to 180 degrees as possible.
- People with pacemakers should consult their physicians before use. Electromagnetic fields in close proximity to heart pacemaker could cause pacemaker interference or pacemaker failure.
- Remove any element or obstacle that may interfere with safe operation of the winch.
- Always use supplied hook strap whenever spooling winch rope in or out, during installation and during operation.
- Always take time to use appropriate rigging techniques for winch pull.

## Assembly Instructions

### ⚠ WARNING

Read the entire Important Safety Information section at the beginning of this manual including all text under subheadings therein before set up or use of this project..

#### **Mounting the Winch:**

1. The mounting plate must be rated to at least the winch's capacity.
2. Align the winch perpendicular to center line of the vehicle at the desired location, and mark the locations of the winch base holes. Compare the dimensions of the marked holes.
3. Before drilling, verify that the installation surface has no hidden components or structural pieces that will be damaged.

NOTE: This winch can generate extreme forces. Select a location that can withstand the rated capacity without damage or weakening. Steel reinforcement plates may be needed or a certified welder may need to weld on additional bracing depending on the mounting location

4. Drill holes appropriate for the hardware at the marked locations.
5. Install the winch using hardware described under Specifications.



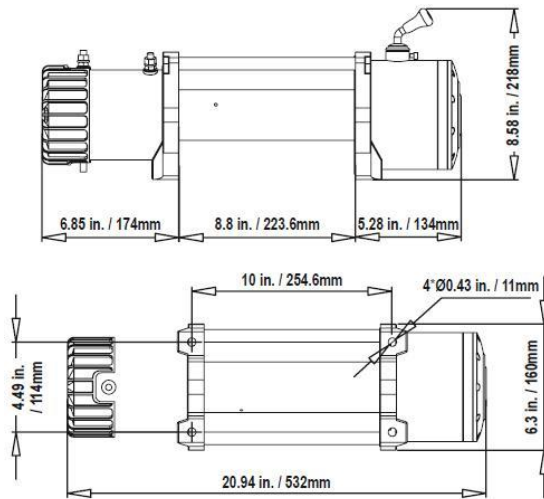

**Mounting the Solenoid Assembly:**

1. Place the solenoid box in a suitable place close enough to the winch to allow the cable to be routed properly.
2. Mark the where the screw holes will be.
3. Verify that the installation surface has no hidden components or structural pieces that will be damaged before drilling.
4. Drill pilot holes for the mounting screws.
5. Secure in place with mounting screws.

**Wiring:**

To prevent serious injury from explosion, due to sparking at the battery connection, disconnect the Battery Cables before making other wiring connections.

To prevent serious injury from leaking battery acid, do not use a dirty, corroded or leaking battery. Only use a 12V automotive (or equivalent) battery, in good condition.

1. Plan a route for the wiring from the point of the vehicle where the winch will be mounted, or used, to the battery. This route must be secure out of the way of moving parts, road debris, or any possibility of being damaged by operation or maintenance of the vehicle. For example, you may wish to route the wires under the vehicle, attaching it to the frame using suitable fasteners Do not attach the wires to the exhaust system, drive shaft, emergency brake cable, fuel line, or any other components which may create damage the wiring through heat or motion, or create a fire hazard.
2. If you drill through the bumper or any part of the body to route the wires, be sure to install a rubber grommet in the hole to prevent fraying of the wires at that point.
3. Route the Cables from the Solenoid to the battery and from the Solenoid to the winch, following the precautions discussed. See the following picture.

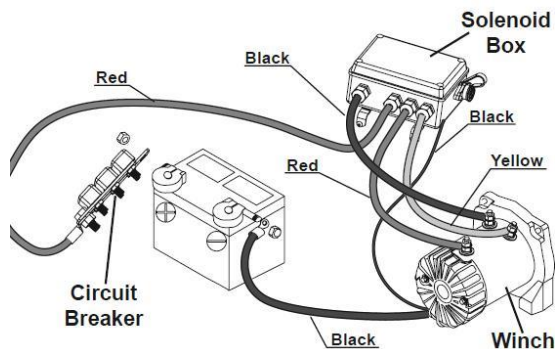

1. Attach the red, black and yellow cables to the terminals on the winch. The winch terminals are color coded.
2. Attach the circuit breaker to the positive terminal on the battery.
3. Attach the red battery cable to the circuit breaker.
4. Attach the black battery cable directly to the negative terminal of the battery.
5. Lift the socket cover exposing the electrical switch connector. Insert the pendant connector into the socket.

**NOTE:** The attachment of the Motor Cables determines the operation of the Remote's button. After the unit is mounted and powered, check the direction of the Power In and Power Out on the Remote button. If you wish to change the direction on the Remote, disconnect the Battery Cables from the battery, switch the Motor Cable connections on the Motor Assembly, then reconnect the Battery Cables.

6. Disconnect the pendant controller when not in use.

### **Preparing the Wire Rope**

1. The wire rope must be properly coiled under tension to be able to support a load without damage.
2. Uncoil the wire rope, expect for 5 full warps.
3. Recoil the rope back into the winch under at least 500 lb. of tension.

## **Before Each Use**

### **⚠WARNING**

- Inspect winch rope, hook, and slings before operating winch. Frayed, kinked or damaged winch rope must be replaced immediately. Damaged components must be replaced before operation.
- Wrap the wire rope under 500 lbs. of tension before use. Otherwise, the wire rope may bind during operation.
- Ventilate area well before and while working on battery. Explosive hydrogen gas can accumulate and explode when ignited by a spark or open flame.
- Remove all jewelry and metallic objects before working near battery.

## **Operating Instructions**

### **⚠WARNING**

- Read the entire Important Safety Information section at the beginning of this manual, including all text under subheadings before set up or use of this electric winch.
- The instructions that follow are basic guidelines only and cannot cover all situations encountered during use. The operator and assistants must carefully plan usage to prevent accidents.

1. Examine the wire rope. Do not use the winch if the wire rope is frayed, kinked or damaged.
2. Fully charge the vehicle's battery.
3. Check the Winch's electrical connections. All connections must be tight and clean.
4. Put the vehicle's transmission in Neutral.
5. If the vehicle where the winch is mounted is not supposed to be moved, engaged the emergency brake and block the wheels using wheel chocks (sold separately).

- To pull out the wire rope, move the clutch control to the released position, shown in below picture, slide the loop of the hook strap over the hook, then pull on the hook strap to pull out the wire rope.

**⚠WARNING**

Leave at least five full turns of wire rope on the drum..

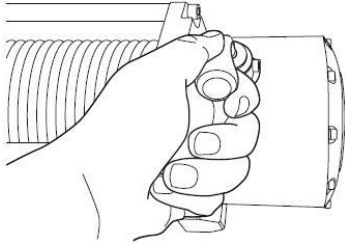

- Hook onto the object using a pulling point, tow strap, tree strap, or chain. See the following picture.

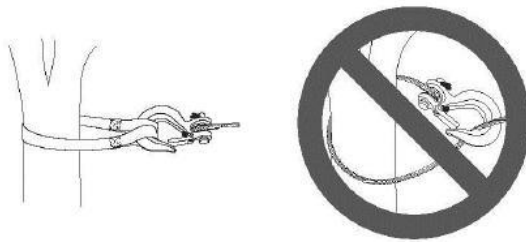

Do not wrap the wire rope around the object and hook onto the wire rope itself. This can damage the object being pulled, and kink or fray the wire rope.

- Attachment point must be centered in loop of hook and the hook's safety clasp must be fully closed. See the following picture.

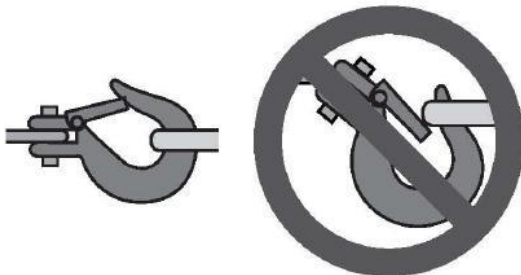

- Do not use a recovery strap while winching. They are designed to stretch and can suddenly whip back towards the operator during a winching operation.
- Place a heavy rag or carpet (sold separately) over the wire rope span, 6 feet from the hook to help absorb the force released if the wire rope breaks.

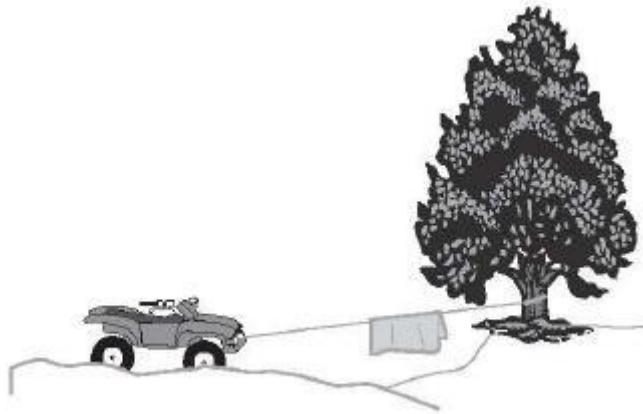

11. Re-engage the clutch by moving the clutch handle to the engaged position, see the following picture.

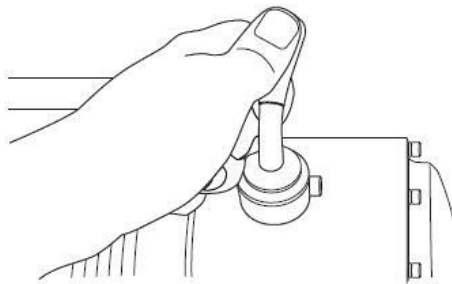

**⚠WARNING**

Do not allow anyone to stand near the wire rope, or in line with the wire rope behind the winch while it is under power. If the wire rope should slip or break, it can suddenly whip back towards the winch, causing a hazard for anyone in the area. Stand far to the side while winching.

12. Attach the pendant controller to the socket on the solenoid assembly. See below picture.

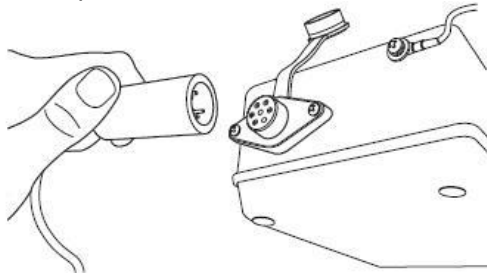

13. Operate the pendant controls briefly to ensure they work properly. See the following picture. If operation is reversed, the power cables may be connected backwards. Correct any such issue before use.

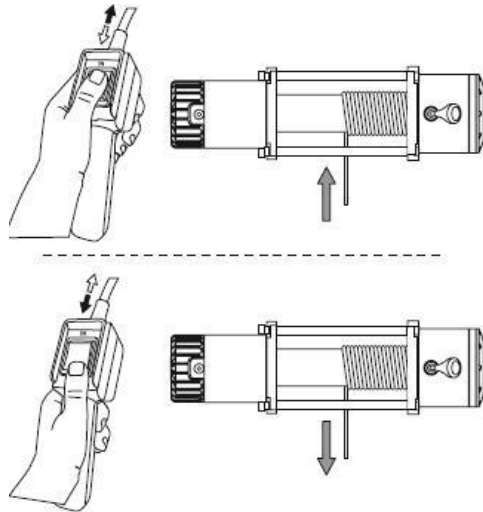

14. When it is safe to do so, use the power switch on the pendant controller to retract the wire rope, and winch the item as desired. Do not power the hook all the way into the fairlead to prevent damage.
15. Do not operate the winch at extreme angles. Do not exceed the angles shown in below picture for a roller fairlead. For a hawse fairlead, the angle should be as close to straight as possible.

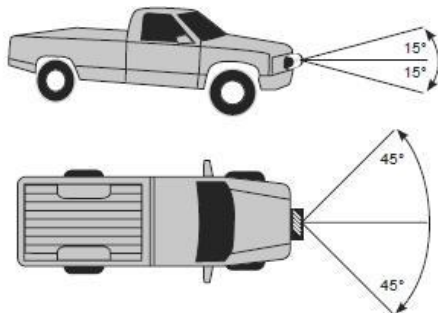

16. If the object to be pulled must be pulled at an angle in relation to the winch, use a pulley (sold separately) and an anchor point directly in front of the winch, as shown in below picture, to keep the wire rope pull straight.

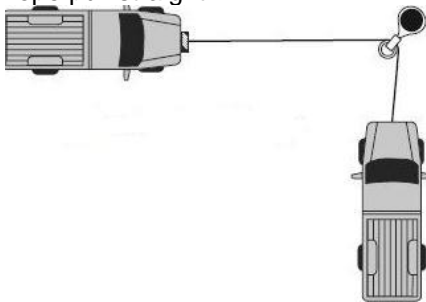

## ⚠ WARNING

Stop the winch and release tension on the wire rope before moving the rag or carpet placed on it..

17. Do not continue use of the winch until the battery is completely run down.
18. You may wish to keep the engine running while using this winch, to continually recharge the battery. However, exercise extreme caution when working around a running vehicle and **ONLY** operate a vehicle in an outdoor area

## ⚠CAUTION

Do not use the winch in a constant duty application; it is designed for INTERMITTENT USE ONLY. Keep the duration of the pulling job as short as possible. If the motor becomes very hot to touch, stop and let it cool down for several minutes. Do not pull for more than one minute at or near the rated load. Do not maintain power to the winch if the motor stalls. Double line rigging will help prevent overloading and should be used whenever practical.

19. When finished pulling the load, reverse the direction of the winch just enough to release tension on the wire rope so that you can unfasten the hook from the load and reel in the wire rope.

### **Duty Cycle (Duration of Use)**

Avoid damage to the winch by not winching for more than the prescribed duty cycle time.

The Duty Cycle defines the amount of time, within a 15 minute period, during which a winch can operate at its maximum capacity without overheating.

For example, this winch with a 5% duty cycle at its maximum load must be allowed to rest for at least 14 minutes, 15 seconds after every 45 seconds of continuous operation. Failure to carefully observe duty cycle limitations can easily over-stress a winch contribution to premature winch failure.

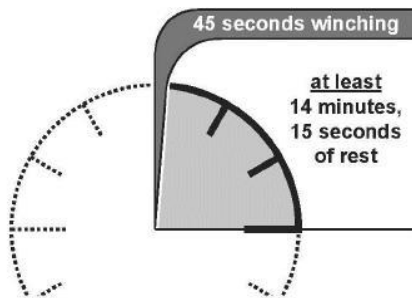

## After Each Use

### ⚠WARNING

Wipe external surfaces of the winch with a clean cloth.

## Maintenance

### ⚠WARNING

- To prevent serious injury from accidental operation: disconnect the battery cables before performing any inspection, maintenance, or cleaning procedures.
- To prevent serious injury from winch failure: do not use damaged equipment. If abnormal noise or vibration occurs, have the problem corrected before further use.
- Lubricate the wire rope occasionally with a light oil
- The winch's internal mechanism is permanently lubricated. Do not open the housing. However, if the winch is submerged, it should be opened, dried, and re-lubricated by a qualified technician as soon as possible to prevent corrosion.

## Troubleshooting

### ⚠WARNING

- Follow all safety precautions whenever diagnosing or servicing the tool.
- Disconnect power supply before service.

Use the table below to troubleshoot problems before contacting service personnel or your local dealer. If the problem continues after troubleshooting, call your local dealer for assistance.

Failure	Possible Cause	Corrective Action
Motor overheats	<ol style="list-style-type: none"> <li>1. Incorrect power cords</li> <li>2. Winch running time too long</li> </ol>	<ol style="list-style-type: none"> <li>1. Use only supplied power cords</li> <li>2. Allow winch to cool down periodically</li> </ol>
Motor does not turn on	<ol style="list-style-type: none"> <li>1. Switch assembly not connected properly.</li> <li>2. Loose battery cable connections</li> <li>3. Vehicle battery needs charging</li> <li>4. Solenoid malfunctioning</li> <li>5. Defective switch assembly</li> <li>6. Defective motor</li> <li>7. Water has entered motor</li> <li>8. Internal damage or wear</li> </ol>	<ol style="list-style-type: none"> <li>1. Insert switch assembly all the way into connector.</li> <li>2. Tighten nuts on all cable connections</li> <li>3. Fully charge battery</li> <li>4. Tap solenoid to loosen contacts. Apply 12 volts to coil terminals directly. A clicking indicates proper activation</li> <li>5. Replace switch assembly</li> <li>6. Check for voltage at armature port with switch pressed. If voltage is present, replace motor</li> <li>7. Allow to drain and dry. Run in short bursts without load until completely dry</li> <li>8. Have technician service winch</li> </ol>
Motor runs but Wire Rope drum does not turn	Clutch not engaged	Move the clutch handle to the engaged position If problem persists, a qualified technician needs to check and repair.
Motor runs slowly or without normal power	<ol style="list-style-type: none"> <li>1. Insufficient current or voltage</li> <li>2. Loose or corroded battery cable connections</li> <li>3. Incorrect power cords</li> </ol>	<ol style="list-style-type: none"> <li>1. Battery weak, recharge. Run winch with vehicle motor running</li> <li>2. Clean, tighten, or replace</li> <li>3. Use only supplied power cords</li> </ol>
Motor runs in one direction only	<ol style="list-style-type: none"> <li>1. Defective or stuck solenoid</li> <li>2. Defective switch assembly.</li> </ol>	<ol style="list-style-type: none"> <li>1. Tap solenoid to loosen contacts. Repair or replace solenoid</li> <li>2. Replace switch assembly.</li> </ol>

## Parts Diagram

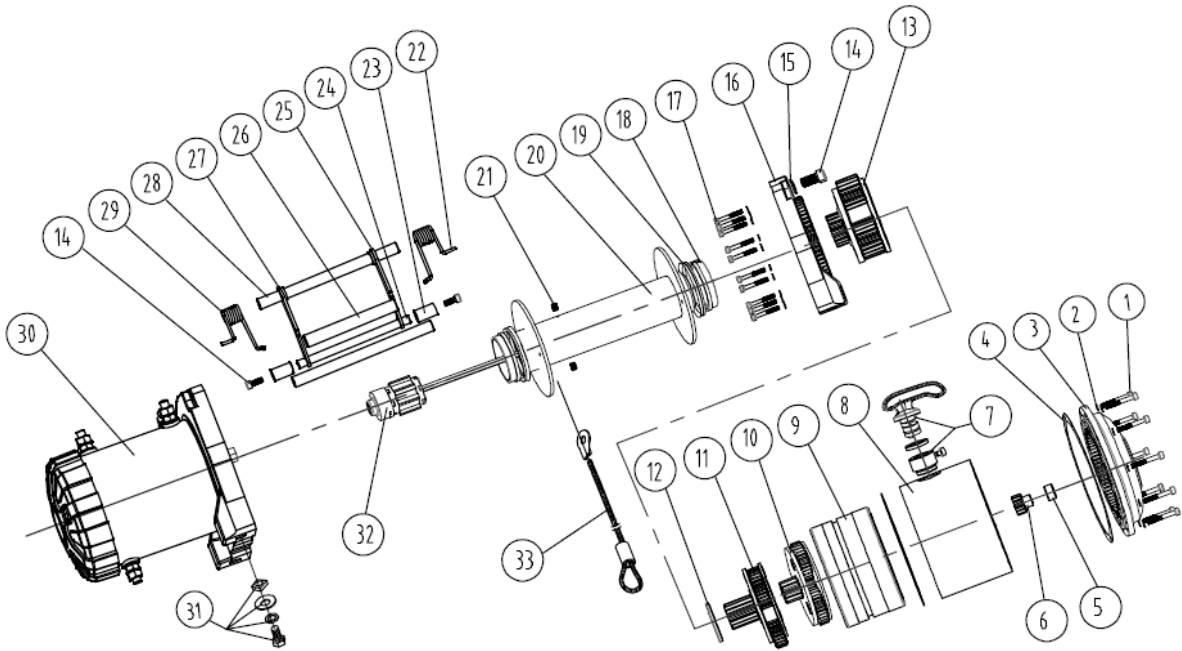

## Parts List

Part Number	Description	Quantity
1	Hex Socket FH Screw M4x20	10
2	Lock Washer 04	22
3	Gearbox End Cover	1
4	Washer	2
5	Bearing	1
6	Sun Gear (Input)	1
7	Clutch Handle Assembly	1
8	Gear Box Tube	1
9	Clutch Gear	1
10	Gear Carrier Assembly Input)	1
11	Gear Carrier Assembly (Intermediate)	1
12	Washer	1
13	Gear Carrier Assembly (Output)	1
14	Tie Bar Screw M8x25	4
15	Tie Bar Washer 8x0.5	4
16	Gear Box Base	1
17	Hex Socket FH Screw M4x18	10
18	Nylon Bearing	2
19	Seal Kit	2
20	Drum Assembly	1
21	Screw M8x10	2
22	Torsional Spring (Left)	1
23	Short Roller	2
24	Roller Shaft	1
25	Pressing Plate (Left)	1
26	Long Roller	1



<b>Part Number</b>	<b>Description</b>	<b>Quantity</b>
27	Pressing Plate (Right)	1
28	Tie Bar	1
29	Torsional Spring (Right)	1
30	Motor Assembly	1
31	Winch Mounting Hardware	4
32	Brake Assembly	1
33	Wire Rope	1
34	Clevis Hook	1
35	Red Strap	1
36	Roller Fairlead	1
37	Fairlead Mounting Hardware	2
38	Control Box	1
39	Pendant Controller	1
40	Power Wire “-“	1
41	Circuit Breaker	1

## Replacement Parts

- For replacement parts and technical questions, please call Customer Service at **1-800-222-5381**.
- Not all product components are available for replacement. The illustrations provided are a convenient reference to the location and position of parts in the assembly sequence.
- When ordering parts, the following information will be required: item description, item model number, item serial number/item lot date code, and the replacement part number.
- The distributor reserves the rights to make design changes and improvements to product lines and manuals without notice.

## Limited Warranty

Northern Tool and Equipment Company, Inc. ("We" or "Us") warrants to the original purchaser only ("You" or "Your") that the Ironton product purchased will be free from material defects in both materials and workmanship, normal wear and tear excepted, for a period of one year from date of purchase. The foregoing warranty is valid only if the installation and use of the product is strictly in accordance with product instructions. There are no other warranties, express or implied, including the warranty of merchantability or fitness for a particular purpose. If the product does not comply with this limited warranty, Your sole and exclusive remedy is that We will, at our sole option and within a commercially reasonable time, either replace the product or product component without charge to You or refund the purchase price (less shipping). This limited warranty is not transferable.

### Limitations on the Warranty

This limited warranty does not cover: (a) normal wear and tear; (b) damage through abuse, neglect, misuse, or as a result of any accident or in any other manner; (c) damage from misapplication, overloading, or improper installation; (d) improper maintenance and repair; and (e) product alteration in any manner by anyone other than Us, with the sole exception of alterations made pursuant to product instructions and in a workmanlike manner.

### Obligations of Purchaser

You must retain Your product purchase receipt to verify date of purchase and that You are the original purchaser. To make a warranty claim, contact Us at 1-800-222-5381, identify the product by make and model number, and follow the claim instructions that will be provided. The product and the purchase receipt must be provided to Us in order to process Your warranty claim. Any returned product that is replaced or refunded by Us becomes our property. You will be responsible for return shipping costs or costs related to Your return visit to a retail store.

### Remedy Limits

Product replacement or a refund of the purchase price is Your sole remedy under this limited warranty or any other warranty related to the product. We shall not be liable for: service or labor charges or damage to Your property incurred in removing or replacing the product; any damages, including, without limitation, damages to tangible personal property or personal injury, related to Your improper use, installation, or maintenance of the product or product component; or any indirect, incidental or consequential damages of any kind for any reason.

### Assumption of Risk

You acknowledge and agree that any use of the product for any purpose other than the specified use(s) stated in the product instructions is at Your own risk.

### Governing Law

This limited warranty gives You specific legal rights, and You also may have other rights which vary from state to state. Some states do not allow limitations or exclusions on implied warranties or incidental or consequential damages, so the above limitations may not apply to You. This limited warranty is governed by the laws of the State of Minnesota, without regard to rules pertaining to conflicts of law. The state courts located in Dakota County, Minnesota shall have exclusive jurisdiction for any disputes relating to this warranty.



Distributed by:

Northern Tool & Equipment Company, Inc.

Burnsville, Minnesota 55306

[www.northerntool.com](http://www.northerntool.com)

Made in China