

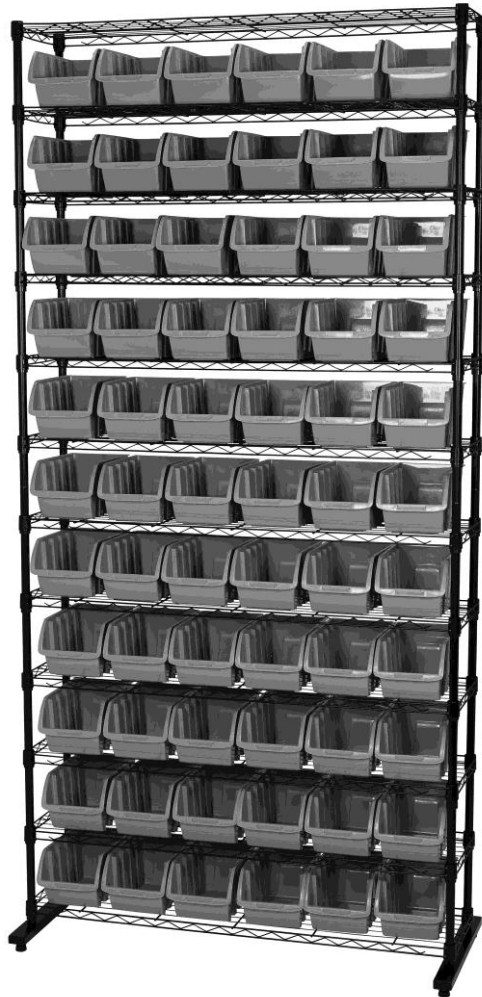

66-Bin Wire Shelf Storage Rack

Owner's Manual



! **WARNING:** Read carefully and understand all ASSEMBLY AND OPERATION INSTRUCTIONS before operating. Failure to follow the safety rules and other basic safety precautions may result in serious personal injury.

Item #53917

SAVE THESE INSTRUCTIONS

Thank you very much for choosing a Strongway™ product!

For future reference, please complete the owner's record below:

Serial Number/Lot Date Code: _____

Purchase Date: _____

Save the receipt, warranty, and this manual. It is important that you read the entire manual to become familiar with this product before you begin using it.

This 66-Bin Wire Shelf Storage Rack is designed for certain applications only. Northern Tool & Equipment is not responsible for issues arising from modification or improper use of this product such as an application for which it was not designed. We strongly recommend that this product not be modified and/or used for any application other than that for which it was designed.

For technical questions, please call **1-800-222-5381**.

Table of Contents

Intended Use.....4

Technical Specifications4

Important Safety Information4

Specific Operation Warnings5

Assembly Instructions.....5

Before Each Use.....8

After Each Use.....8

Parts Diagram.....9

Parts List.....9

Replacement Parts9

Limited Warranty10

Intended Use

This 66-Bin Wire Shelf Storage Rack with versatile storage bins can be used in the shop, garage, home, and virtually anywhere. The storage rack has a strong powder coating finish and can assemble easily. The bins are made of durable Polypropylene material.

Technical Specifications

Property	Specification
Capacity Per Medium Bin	4 lbs.
Capacity Per Shelf	100 lbs. (evenly distributed)
Medium Bin Dimensions, L x W x H	6" x 9" x 5"
Shelf Dimensions, L x W	39" x 10"
Rack Dimensions, L x W x H	39" x 16" x 80.5"

Important Safety Information

⚠WARNING

- Read and understand all instructions. Failure to follow all instructions may result in serious injury or property damage.
- The warnings, cautions, and instructions in this manual cannot cover all possible conditions or situations that could occur. Exercise common sense and caution when using this storage rack. Always be aware of the environment and ensure that the storage rack is used in a safe and responsible manner.
- Do not allow persons to operate or assemble the storage rack until they have read this manual and have developed a thorough understanding of how it works.
- Do not modify this storage rack in any way. Unauthorized modification may impair the function and/or safety and could affect the life of the product. There are specific applications for which the product was designed.
- Use the right tool for the job. DO NOT attempt to force small equipment to do the work of larger industrial equipment. There are certain applications for which this equipment was designed. It will be a safer experience and do the job better at the capacity for which it was intended. DO NOT use this equipment for a purpose for which it was not intended.
- Industrial or commercial applications must follow OSHA requirements.

⚠WARNING

WORK AREA SAFETY

- Inspect the work area before each use. Keep work area clean, dry, free of clutter, and well-lit. Cluttered, wet, or dark work areas can result in injury. Using the storage rack in confined work areas may put you dangerously close to other cutting tools and rotating parts.

⚠ CAUTION

STORAGE RACK USE AND CARE

- Do not force the storage rack. Products are safer and do a better job when used in the manner for which they are designed. Plan your work, and use the correct product for the job.
- Check for damaged parts before each use. Carefully check that the product will operate properly and perform its intended function. Replace damaged or worn parts immediately. Never operate the product with a damaged part.
- Store the storage rack when it is not in use. Store it in a dry, secure place out of the reach of children. Inspect the tool for good working condition prior to storage and before re-use.
- Use only accessories that are recommended by the manufacturer for use with your product. Accessories that may be suitable for one product may create a risk of injury when used with another tool. Never use an accessory that has a lower operating speed or operating pressure than the tool itself.

Specific Operation Warnings

⚠ WARNING

- Do not lean, pull, or hang items on the storage rack. Tipping may occur resulting in personal injury.
- Do not exceed the rated load capacity of each bin, shelf, or the storage rack as whole.
- Be sure to evenly distribute loads. Concentrating loads may cause the rack to fail, causing property damage or personal injury.
- Do not climb on the storage rack. It may tip over causing personal injury.
- Be sure storage rack is secured to wall at all times.
- When using the back stop feature to pull out the bin and hang on the rack, do not pull out more than one row of bins at a time. Tipping may occur, resulting in personal injury or property damage.
- Do not allow children to play on or near the storage rack.

Assembly Instructions

For easiest assembly, do not attach the TOP (B), MIDDLE (C) and BOTTOM (D) POLES until Step 5. Once connected, these will be the posts for the storage rack. Each POLE (B+C+D) has slight horizontal line indentations at each shelf position. Each SLIP SLEEVE (F) has raised horizontal lines inside designed to lock them in place on the POLE (B+C+D).

STEP 1

On each BOTTOM POLE (D), place 1 pair of SLIP SLEEVES (F) at the lowest position. BASE (E) end should be pointed down. Make sure the arrows on SLIP SLEEVES (F) faces up and that the word 'TOP' is right side up.

Slide the pair of SLIP SLEEVES (F) until you hear a click to confirm the pair is locked onto the BOTTOM POLE (D). DO NOT place more than one pair on each POLE at a time.

Note: There will be a very small gap in-between the SLIP SLEEVES (F)—this is normal.

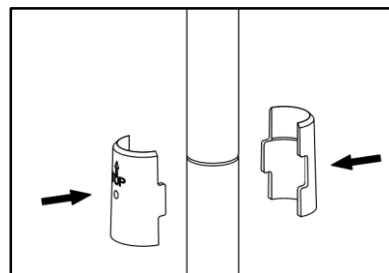

STEP 2

Place a SHELF (A) on its side and slide the (4) BOTTOM POLES (D) through the holes in the SHELF (A). Make sure that the SHELF (A) corner cylinders are positioned over the SLIP SLEEVES (F).

Take 2 SCREWS (G) and put them through the bottom of the BASE (E), the side with the feet levelers, and fasten them to BOTTOM POLES (D). Tighten the SCREWS (G) with the ALLEN KEY (H).

Repeat with the other BASE (E).

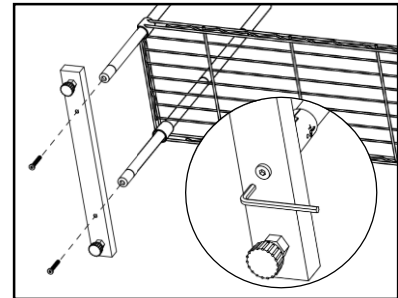
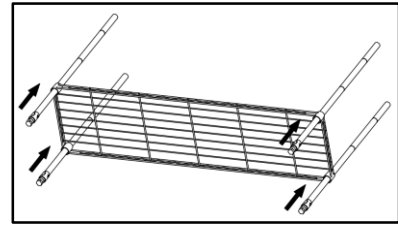

STEP 3

Stand the unit upright and push each corner of the shelf until the top of the SLIP SLEEVES (F) are flush with top of the corner cylinders on the shelf.

Note: The level side of the SHELF (A) is the TOP side (Strongway logo on the corner cylinders should be right-side up). Use a rubber mallet, if needed, to secure the SHELVES (A).

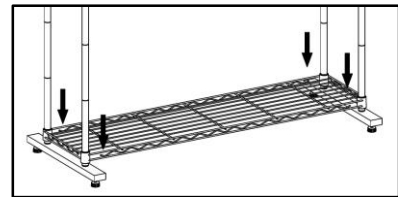

STEP 4

Install the next set of SLIP SLEEVES (F) on the (4) BOTTOM POLES (D) in the next position up from the bottom. Place another SHELF (A) over the BOTTOM POLES (D) and secure the SHELF (A) so the top of the SLIP SLEEVES (F) are flush with top of the corner cylinders on the SHELF (A).

Repeat until all shelf positions on the BOTTOM POLES (D) have a SHELF (A).

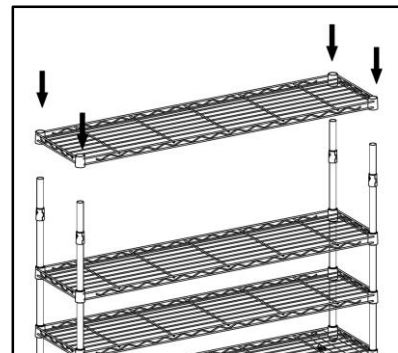

STEP 5

Screw the MIDDLE POLE (C) into the BOTTOM POLE (D). The bottoms of the MIDDLE POLE (C) are indicated by pre-installed pole connectors. Make sure all (4) MIDDLE POLES (C) are screwed on tightly.

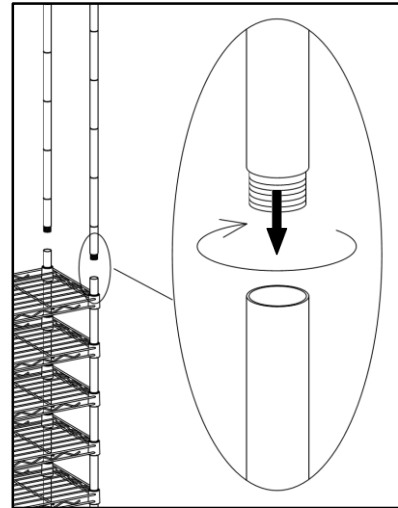

STEP 6

Starting with lowest position install the next set of SLIP SLEEVES (F) on (4) MIDDLE POLES (C). Place another SHELF (A) over the poles and secure the SHELF (A) so top of the SLIP SLEEVES (F) are flush with top of the corner cylinders on the SHELF (A).

Repeat until all shelf positions on the MIDDLE POLES (C) have a SHELF (A).

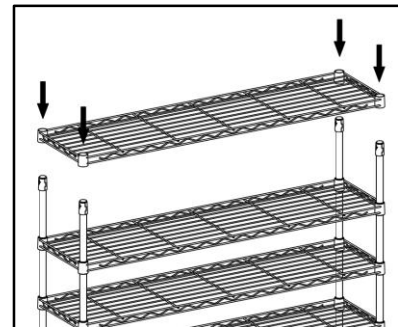

STEP 7

Screw the TOP POLE (B) into the MIDDLE POLE (C). The tops of these poles are indicated by the BLACK END CAP. Make sure all (4) TOP POLES (B) are screwed on tightly.

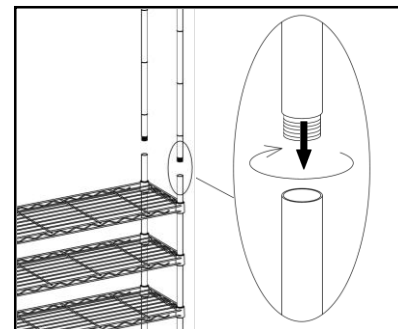

STEP 8

Starting with lowest position install the next set of SLIP SLEEVES (E) on (4) TOP POLES (B). Place another SHELF (A) over the poles and secure the SHELF (A) so top of the SLIP SLEEVES (E) are flush with top of the corner cylinders on the SHELF (A).

Repeat until all shelf positions on the TOP POLES (B) have a SHELF (A).

The Feet Levelers are already screwed into your BASE (E) and you can adjust as needed to ensure your storage rack is level.

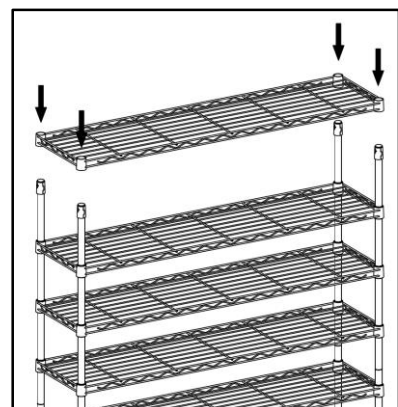

STEP 9

Place (6) BINS (I) onto each shelf.

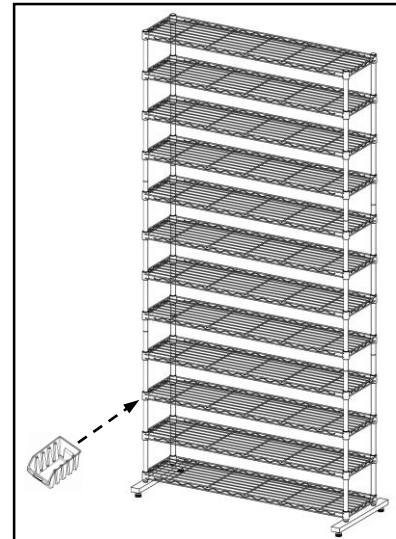

Before Each Use

- Before using a new bin or reloading an existing bin, check for any damage. Carefully check that the bins will safely hold the intended parts.
- Replace damaged or worn parts immediately. Never load the storage rack when it has a damaged part.

After Each Use

- Store the storage rack when not in use. Store it in a secure place out of the reach of children.
- Inspect the rack for good working condition before storage and again before the next use.

Parts Diagram

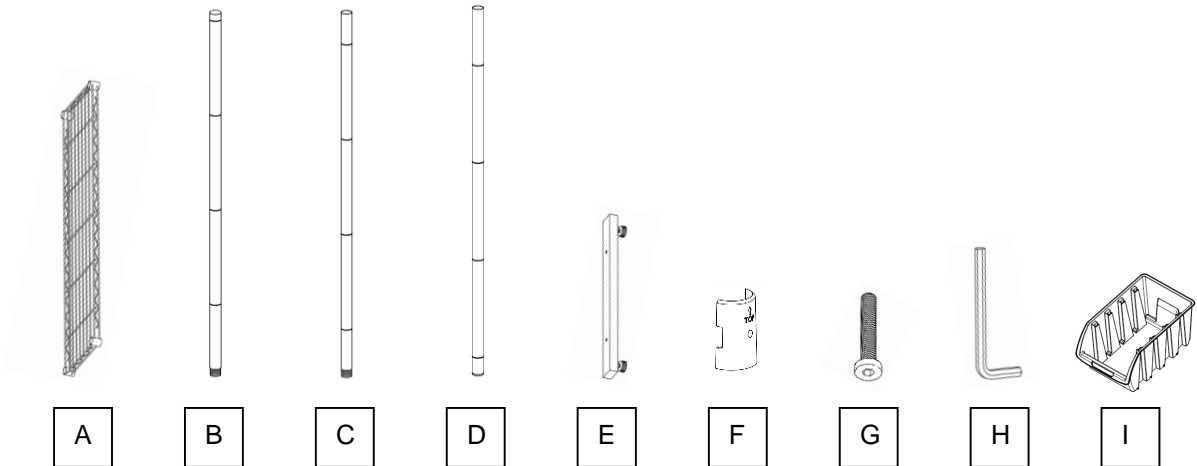

Parts List

Reference	Part Number	Part Description	Quantity	Remark
A	PBK-03-014-3910	SHELF	12	
B	PBK-04-013-2625	TOP POLE	4	End Cap (4) and Pole Connector (4) are pre-installed
C	PBK-04-014-2625	MIDDLE POLE	4	Pole Connector (4) are pre-installed
D	PBK-04-015-2625	BOTTOM POLE	4	
E	PBK-13-004-1600	BASE	2	Feet Leveler (4) are pre-installed
F	XBK-01-012-1936	SLIP SLEEVE	96	
G	ZBK-01-002-0635	SCREW	4	
H	XXX-97-001-0001	HEX KEY	1	
I	XGR-21-006-0605	BIN	66	Light gray

Replacement Parts

- For replacement parts and technical questions, please call Customer Service at **1-800-222-5381**.
- Not all product components are available for replacement. The illustrations provided are a convenient reference to the location and position of parts in the assembly sequence.
- When ordering parts, the following information will be required: item description, item model number, item serial number/item lot date code, and the replacement part reference number.
- The distributor reserves the rights to make design changes and or improvements to product lines and manuals without notice.

Limited Warranty

Northern Tool and Equipment Company, Inc. ("We" or "Us") warrants to the original purchaser only ("You" or "Your") that the Strongway product purchased will be free from material defects in both materials and workmanship, normal wear and tear excepted, for a period of one year from date of purchase. The foregoing warranty is valid only if the installation and use of the product is strictly in accordance with product instructions. There are no other warranties, express or implied, including the warranty of merchantability or fitness for a particular purpose. If the product does not comply with this limited warranty, Your sole and exclusive remedy is that We will, at our sole option and within a commercially reasonable time, either replace the product or product component without charge to You or refund the purchase price (less shipping). This limited warranty is not transferable.

Limitations on the Warranty

This limited warranty does not cover: (a) normal wear and tear; (b) damage through abuse, neglect, misuse, or as a result of any accident or in any other manner; (c) damage from misapplication, overloading, or improper installation; (d) improper maintenance and repair; and (e) product alteration in any manner by anyone other than Us, with the sole exception of alterations made pursuant to product instructions and in a workmanlike manner.

Obligations of Purchaser

You must retain Your product purchase receipt to verify date of purchase and that You are the original purchaser. To make a warranty claim, contact Us at 1-800-222-5381, identify the product by make and model number, and follow the claim instructions that will be provided. The product and the purchase receipt must be provided to Us in order to process Your warranty claim. Any returned product that is replaced or refunded by Us becomes our property. You will be responsible for return shipping costs or costs related to Your return visit to a retail store.

Remedy Limits

Product replacement or a refund of the purchase price is Your sole remedy under this limited warranty or any other warranty related to the product. We shall not be liable for: service or labor charges or damage to Your property incurred in removing or replacing the product; any damages, including, without limitation, damages to tangible personal property or personal injury, related to Your improper use, installation, or maintenance of the product or product component; or any indirect, incidental or consequential damages of any kind for any reason.

Assumption of Risk

You acknowledge and agree that any use of the product for any purpose other than the specified use(s) stated in the product instructions is at Your own risk.

Governing Law

This limited warranty gives You specific legal rights, and You also may have other rights which vary from state to state. Some states do not allow limitations or exclusions on implied warranties or incidental or consequential damages, so the above limitations may not apply to You. This limited warranty is governed by the laws of the State of Minnesota, without regard to rules pertaining to conflicts of law. The state courts located in Dakota County, Minnesota shall have exclusive jurisdiction for any disputes relating to this warranty.



Distributed by:

Northern Tool & Equipment Company, Inc.

Burnsville, Minnesota 55306

www.northerntool.com

Made in China