

Magnum Vertical Mast Light Tower – MLT4060MV Specifications

ENGINE

- Mitsubishi® L3E-W461ML - liquid cooled, diesel engine
 - Standby - 12.2 hp @ 1800 rpm
 - Prime - 10.5 hp @ 1800 rpm
 - 3 cylinder
 - 0.95 L displacement
- Fuel consumption (prime) – 0.47 gph (1.78 Lph)
- 60 Hz engine/generator
- Industrial engine exhaust system
- Rubber vibration dampers isolate engine/generator from frame
- Cooling system capable of operating at 120°F ambient
- Full flow oil filter, spin on type
- Fuel filter with replaceable element
- Dry type cartridge air filter
- Polyethylene fuel tank with large diameter opening
 - 56 gal. capacity
 - 119 hr. run capacity
 - 3 ½" fill port

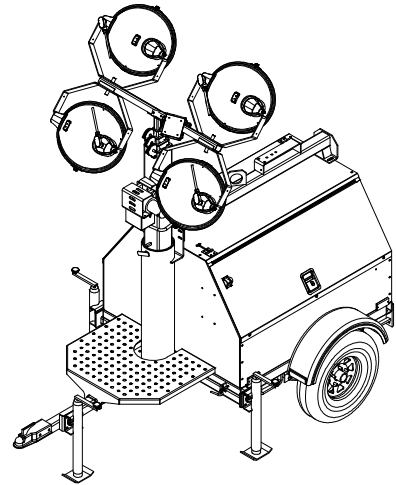

ENGINE CONTROLS

- Engraved, aluminum punched and anodized control panel
- Four position keyed switch – glow plugs (preheat, off, run, start)
- Hour meter
- Automatic low oil/high temperature shutdown system

GENERATOR

- Marathon Electric®
 - Brushless
- 6 kW standby output
- 120/240 VAC – 50/25A
- +/-6% capacitor voltage regulation

ELECTRICAL SYSTEM AND CONTROLS

- Single toggle switch for raising /lowering vertical mast
- Individual floodlight circuits with 15A breakers
- Ballast indicator lights
- 30A start limit breaker (assures no load condition exists before starting)
- Standard individually breakered convenience outlets:
 - (1) 120 VAC 20 Amp GFCI duplex outlets (Nema 5-20R type)
 - (1) 240 VAC 30 Amp twistlock outlets (Nema L6-30R type)
- 440 CCA wet cell battery

FLOODLIGHTS

- Four light fixtures – 1000 watts each - metal halide
- Oval aluminum reflector
- Tempered glass lens
- Silicone gaskets for moisture and dust protection
- Individual floodlight On/Off switches

WIRING

- All wiring is sized to the amperage draw required
- AC & DC wiring diagrams are provided

MAST

- LightTracking System - distinctive angle fixture design for common light distribution
- Mast stowed height: 9.25 ft.
- 25ft. maximum extension, 5-section, tubular steel
- Urethane guides on all sides of mast tubes
- Industrial black powder coat finish
- 950 lb. automatic self-breaking electric winch – easily raises mast vertically
- 360° ground-level rotation with locking system
- Coiled mast cord
- Equipped with single lifting eye and fork pockets

ENCLOSURE

- Steel enclosure – 14-gauge
 - UV& fade resistant, high temperature cured, white polyester powder paint
 - 68 dB(A) at 23 feet – prime power
- Stainless steel hinges on doors
- Multi-lingual operating/safety decals
- License plate holder with light
- Manual holder with operating manual

TRAILER

- Front step platform for easy adjustment of light fixtures
- Removable tongue - 48” long
- Tubular steel frame - 3/16” wall
- Four, 2000 lb. adjustable leveling jacks – 4 point stance
- All jacks transport and lock in horizontal position for storage
- Side outriggers - 11’ 8” span
- Safety chains with spring loaded safety hooks
- 2” ball hitch
- Single wall polyethylene fenders
- DOT approved tail, side, brake, and directional lights
 - Recessed rear lights
- 2200 lb. leaf spring axle
- ST175/80D13 – 6 ply
- 56 in. axle span

WEIGHTS & DIMENSIONS

- Dry weight: 1759lbs (798 kg)
- Operating weight: 2162 lbs (981 kg)
- Mast stowed: 115 x 63 x 111 in (2.92 x 1.73 x 2.82)

WARRANTY

- Engine and generator covered under OEM warranty – consult factory for details.

CERTIFICATIONS

- CSA certified

MLT4060MV Options

COOLANT OPTIONS

- ◆ 60/40 Coolant, 60% Ethylene glycol

ENGINE OPTIONS

- ◆ Heated fuel filter
- ◆ Oil drain valve kit
- ◆ Lower radiator hose – engine heater
- ◆ Cold weather belt

ELECTRICAL CONTROLS OPTIONS

- ◆ 720 CCA wet cell battery
- ◆ 720 CCA AGM sealed battery (Optima)
- ◆ 775 AGM sealed battery
- ◆ Battery disconnect
- ◆ Battery charger – 2A trickle
- ◆ Autolight controller
- ◆ Alternative generator – electronically regulated

CABINET OPTIONS

- ◆ Interior cabinet light
- ◆ Level indicator

HITCH OPTIONS

- ◆ 2.5” lunette ring
- ◆ 3” lunette ring
- ◆ 3” HD lunette ring
- ◆ 2 5/16” ball
- ◆ Combination hitch – 2.5” lunette ring / 2” ball

TRAILER OPTIONS

- ◆ Tube and sleeve jack
- ◆ 6 pin or 7 spade connectors
- ◆ Spare tire and carrier
- ◆ Parking brake
- ◆ Electric brakes
- ◆ Surge brakes

LIGHT OPTIONS

- ◆ High pressure sodium, quick disconnect lights