



Utility Cart

Owner's Manual



⚠ WARNING: Read carefully and understand all ASSEMBLY AND OPERATION INSTRUCTIONS before operating. Failure to follow the safety rules and other basic safety precautions may result in serious personal injury.

Item #53172

SAVE THESE INSTRUCTIONS

Thank you very much for choosing a Strongway™ product!

For future reference, please complete the owner's record below:

Serial Number/Lot Date Code: _____

Purchase Date: _____

Save the receipt, warranty, and this manual. It is important that you read the entire manual to become familiar with this product before you begin using it.

This utility cart is designed for certain applications only. Northern Tool & Equipment is not responsible for issues arising from modification or improper use of this product such as an application for which it was not designed. We strongly recommend that this product not be modified and/or used for any application other than that for which it was designed.

For technical questions, please call **1-800-222-5381**.

Table of Contents

Intended Use.....4

Technical Specifications4

Important Safety Information4

Specific Operation Warnings5

Assembly Instructions.....6

Before Each Use.....7

After Each Use.....7

Parts Diagram.....8

Parts List.....8

Replacement Parts9

Limited Warranty10

Intended Use

Strongway's heavy-duty structural foam construction makes this utility cart tough enough for long, rugged use. It's easy to assemble and handles a wide variety of industrial and commercial handling needs.

Technical Specifications

Property	Specification
Capacity	500 lbs.
Shelves (qty)	2
Product Size	41-1/2" x 16-15/16" x 34-13/16"
Wheel Size	5" (4 pieces)

Important Safety Information

⚠️WARNING

- Read and understand all instructions. Failure to follow all instructions may result in serious injury or property damage.
- The warnings, cautions, and instructions in this manual cannot cover all possible conditions or situations that could occur. Exercise common sense and caution when using this cart. Always be aware of the environment and ensure that the cart is used in a safe and responsible manner.
- Do not allow persons to operate or assemble the cart until they have read this manual and have developed a thorough understanding of how it works.
- Do not modify this cart in any way. Unauthorized modification may impair the function and/or safety and could affect the life of the cart. There are specific applications for which the product was designed.
- Use the right tool for the job. DO NOT attempt to force small equipment to do the work of larger industrial equipment. There are certain applications for which this equipment was designed. It will be a safer experience and do the job better at the capacity for which it was intended. DO NOT use this equipment for a purpose for which it was not intended.
- Industrial or commercial applications must follow OSHA requirements.

⚠️WARNING

WORK AREA SAFETY

- Inspect the work area before each use. Keep work area clean, dry, free of clutter, and well-lit. Cluttered, wet, or dark work areas can result in injury. Using the cart in confined work areas may put you dangerously close to other cutting tools and rotating parts.
- Keep children and bystanders away from the work area while operating the cart. Do not allow children to handle the cart.

⚠️WARNING

PERSONAL SAFETY

- Stay alert, watch what you are doing, and use common sense when operating the tool. Do not use the cart while you are tired or under the influence of drugs, alcohol, or medication. A moment of inattention while operating the cart may result in serious personal injury.
- Dress properly. Do not wear loose clothing, dangling objects, or jewelry. Keep your hair, clothing and gloves away from moving parts. Loose clothes, jewelry, or long hair can be caught in moving parts. Air vents on the tool often cover moving parts and should be avoided.
- Wear the proper personal protective equipment when necessary. Use ANSI Z87.1 compliant safety goggles (not safety glasses) with side shields, or when needed, a face shield. Use a dust mask in dusty work conditions. Also use non-skid safety shoes, hardhat, gloves, dust collection systems, and hearing protection when appropriate. This applies to all persons in the work area.
- Do not overreach. Keep proper footing and balance at all times.

⚠CAUTION

CART USE AND CARE

- Do not force the cart. Products are safer and do a better job when used in the manner for which they are designed. Plan your work, and use the correct product for the job.
- Check for damaged parts before each use. Carefully check that the cart will operate properly and perform its intended function. Replace damaged or worn parts immediately. Never operate the cart with a damaged part.
- Do not use a product with a malfunctioning switch. Any power tool that cannot be controlled with the power switch is dangerous and must be repaired by an authorized service representative before using.
- Disconnect the power/air supply from the product and place the switch in the locked or off position before making any adjustments, changing accessories, or storing the tool. Such preventive safety measures reduce the risk of starting the tool accidentally.
- Store the cart when it is not in use. Store it in a dry, secure place out of the reach of children. Inspect the tool for good working condition prior to storage and before re-use.
- Use only accessories that are recommended by the manufacturer for use with your cart. Accessories that may be suitable for one product may create a risk of injury when used with another tool. Never use an accessory that has a lower operating speed or operating pressure than the tool itself.
- Keep guards in place and in working order. Never operate the cart without the guards in place.
- Do not leave the tool running unattended.

Specific Operation Warnings

⚠WARNING

- Do not exceed the rated load capacity.
- Be aware of dynamic loading. A sudden loading movement may briefly create an excess load causing product failure.
- Do not allow riders.
- Use only on a hard level surface.
- Inspect before each use. Do not use if parts are damaged.

Assembly Instructions

Refer to the Parts Diagram for the following assembly instructions.

1. Locate the second Base Plate (7) and turn it upside down. Set the second Base Plate (7) onto the Beams (6). See Figure A.
2. Turn the cart upside down. Attach two Casters (13) with the Swivel Caster Brackets (11) using a Nut (12) and Axle (14), if necessary. Thread a Carriage Bolt (8) through the Base Plate (7) and into the Casters (13). Attach one Washer (9) and one Nut (10) for each hole. See Figure B.
3. Attach another two Casters (13) to with the Fixed Caster Brackets (15) using a Nut (12) and Axle (14), if necessary. Thread a Carriage Bolt (8) through the Base Plate (7) and into the Casters (13). Attach one Washer (9) and one Nut (10) for each hole. See Figure B.
4. Locate the two Beams (6). Place one on the Platform (4) corner nearest the Handle (1), and place one on the diagonal corner located on the outside of the Platform (4), as in the assembly diagram. Make certain that the end with the screw holes is facing upward. Using a rubber mallet, tap the Beams (6) down into the Platform (4). Note: Position the Beams so that the flange in each matches the space in the Platform (4). Insert Screws (5) down through each Beam (6) and into the Platform (4). See Figure C.
5. Locate another two Beams (6). Place one on the Platform (4) corner nearest the Handle (1), and place one on the diagonal corner located on the outside of the Platform (4), as in the assembly diagram. Make certain that the end with the screw holes is facing upward. Using a rubber mallet, tap the Beams (6) down into the Platform (4). See Figure C.
6. Place the two Swivel Caster Brackets on the same side of the Platform (4) as the Handle (#1). Place the two Fixed Caster Brackets on the other side of the Platform (4).
7. Place one Platform (4) upside down on the work surface. Locate the Handle (1). Attach the Handle (1) with Platform (4) using Screw (2 & 3). Making certain that both Trays are facing the same way. See Figure D.
8. Turn the cart upright. Make certain that all hardware is tight. Make certain that the Fixed Casters and Swivel Casters roll properly.

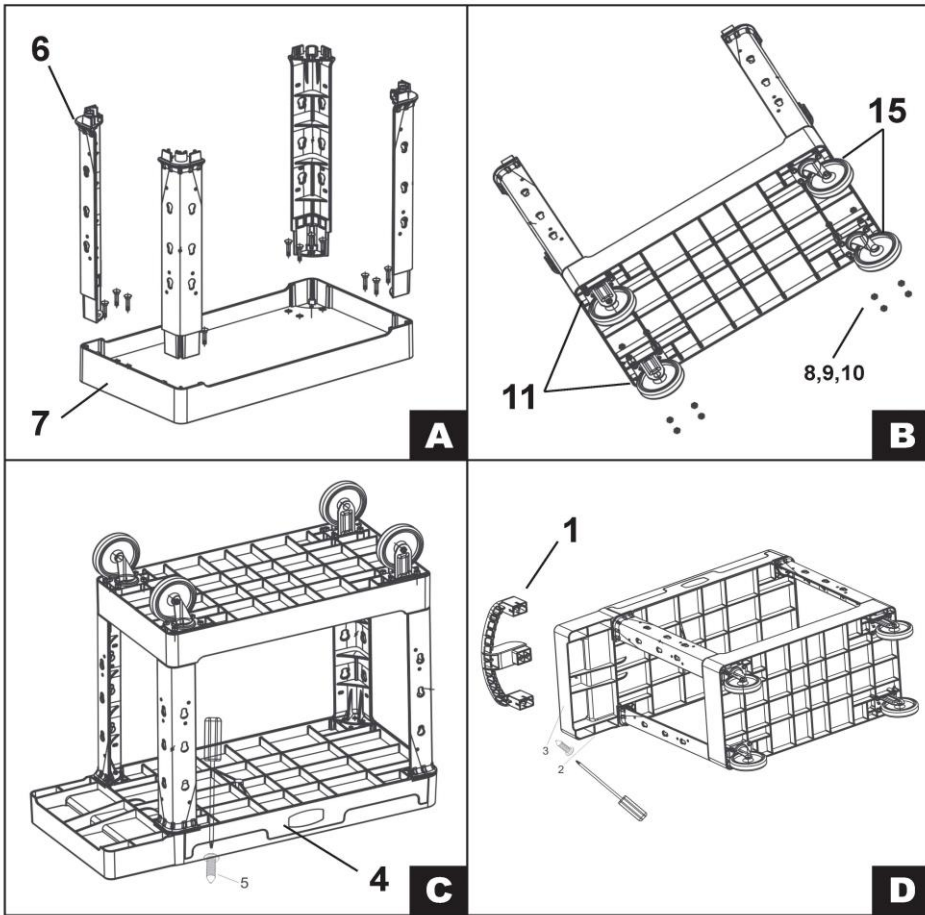

Before Each Use

⚠WARNING

Inspect the unit before every use; do not use if parts are loose or damaged.

After Each Use

⚠WARNING

Inspect the unit before every use; do not use if parts are loose or damaged.

Parts Diagram

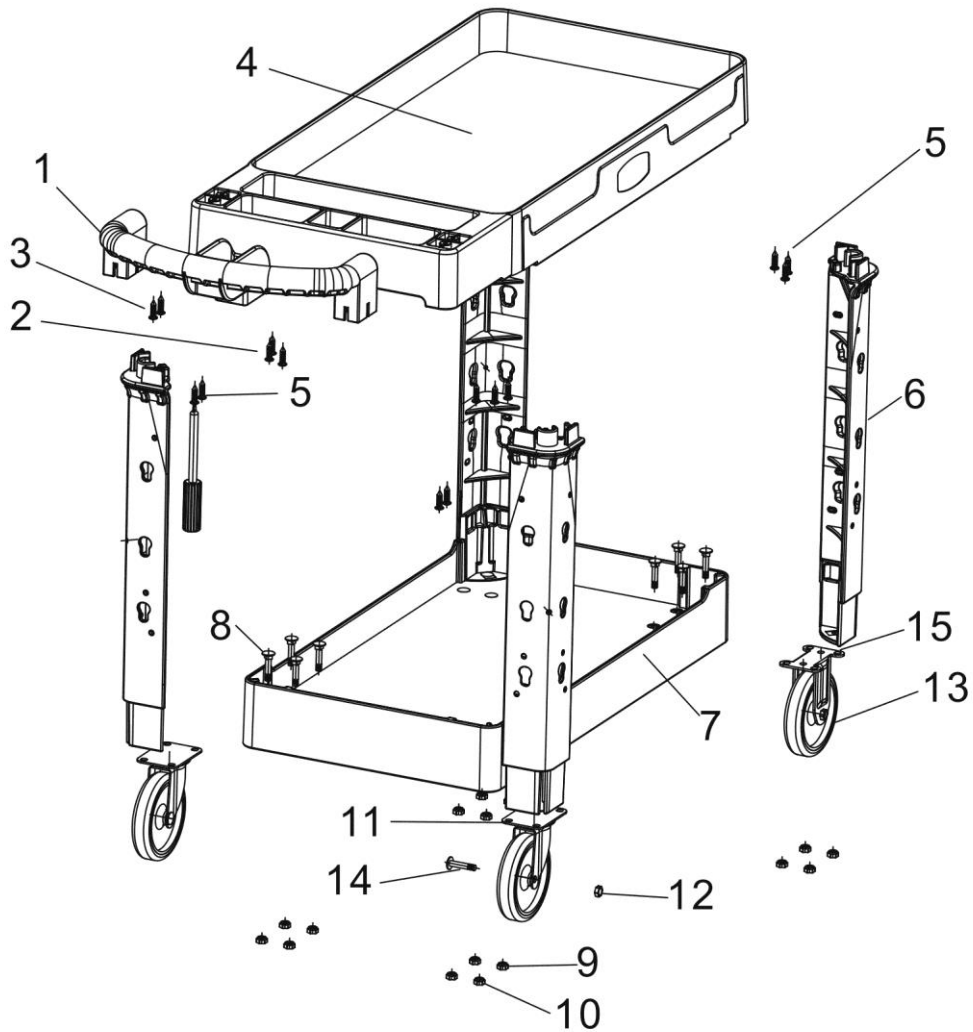

Parts List

Reference	Part Number	Part Description	Quantity
1	1	HANDLE	1
2	2	SCREW	2
3	3	SCREW	4
4	4	PLATFORM	1
5	5	SCREW	12
6	6	BEAM	4
7	7	BASE PLATE	1

Reference	Part Number	Part Description	Quantity
8	8	CARRIAGE BOLT	16
9	9	WASHER	16
10	10	NUT	16
11	11	BRACKET OF SWIVEL CASTER	2
12	12	NUT	4
13	13	CASTER	4
14	14	AXLE	4
15	15	BRACKET OF FIXED CASTER	2

Replacement Parts

- For replacement parts and technical questions, please call Customer Service at **1-800-222-5381**.
- Not all product components are available for replacement. The illustrations provided are a convenient reference to the location and position of parts in the assembly sequence.
- When ordering parts, the following information will be required: item description, item model number, item serial number/item lot date code, and the replacement part reference number.
- The distributor reserves the rights to make design changes and or improvements to product lines and manuals without notice.

Limited Warranty

Northern Tool and Equipment Company, Inc. ("We" or "Us") warrants to the original purchaser only ("You" or "Your") that the Strongway product purchased will be free from material defects in both materials and workmanship, normal wear and tear excepted, for a period of **one year** from date of purchase. The foregoing warranty is valid only if the installation and use of the product is strictly in accordance with product instructions. There are no other warranties, express or implied, including the warranty of merchantability or fitness for a particular purpose. If the product does not comply with this limited warranty, Your sole and exclusive remedy is that We will, at our sole option and within a commercially reasonable time, either replace the product or product component without charge to You or refund the purchase price (less shipping). This limited warranty is not transferable.

Limitations on the Warranty

This limited warranty does not cover: (a) normal wear and tear; (b) damage through abuse, neglect, misuse, or as a result of any accident or in any other manner; (c) damage from misapplication, overloading, or improper installation; (d) improper maintenance and repair; and (e) product alteration in any manner by anyone other than Us, with the sole exception of alterations made pursuant to product instructions and in a workmanlike manner.

Obligations of Purchaser

You must retain Your product purchase receipt to verify date of purchase and that You are the original purchaser. To make a warranty claim, contact Us at 1-800-222-5381, identify the product by make and model number, and follow the claim instructions that will be provided. The product and the purchase receipt must be provided to Us in order to process Your warranty claim. Any returned product that is replaced or refunded by Us becomes our property. You will be responsible for return shipping costs or costs related to Your return visit to a retail store.

Remedy Limits

Product replacement or a refund of the purchase price is Your sole remedy under this limited warranty or any other warranty related to the product. We shall not be liable for: service or labor charges or damage to Your property incurred in removing or replacing the product; any damages, including, without limitation, damages to tangible personal property or personal injury, related to Your improper use, installation, or maintenance of the product or product component; or any indirect, incidental or consequential damages of any kind for any reason.

Assumption of Risk

You acknowledge and agree that any use of the product for any purpose other than the specified use(s) stated in the product instructions is at Your own risk.

Governing Law

This limited warranty gives You specific legal rights, and You also may have other rights which vary from state to state. Some states do not allow limitations or exclusions on implied warranties or incidental or consequential damages, so the above limitations may not apply to You. This limited warranty is governed by the laws of the State of Minnesota, without regard to rules pertaining to conflicts of law. The state courts located in Dakota County, Minnesota shall have exclusive jurisdiction for any disputes relating to this warranty.



Distributed by:

Northern Tool & Equipment Company, Inc.

Burnsville, Minnesota 55306

www.northerntool.com

Made in China