



420cc OHV Horizontal Gas Engine

Owner's Manual



⚠ WARNING: Read carefully and understand all ASSEMBLY AND OPERATION INSTRUCTIONS before operating. Failure to follow the safety rules and other basic safety precautions may result in serious personal injury.

Item #750122

SAVE THESE INSTRUCTIONS

Thank you very much for choosing a Powerhorse® product!

For future reference, please complete the owner's record below:

Serial Number/Lot Date Code: _____

Purchase Date: _____

Save the receipt, warranty, and this manual. It is important that you read the entire manual to become familiar with this product before you begin using it.

This engine is designed for certain applications only. Northern Tool & Equipment is not responsible for issues arising from modification or improper use of this product such as an application for which it was not designed. We strongly recommend that this product not be modified and/or used for any application other than that for which it was designed.

For technical questions, please call **1-866-443-2576**.

Table of Contents

Technical Specifications	4
Important Safety Information	4
Specific Operation Warnings	6
Safety Labels	8
Main Engine Parts	9
Before Each Use.....	10
Operating Instructions.....	11
Maintenance	16
Troubleshooting.....	25
Storage	25
Parts Diagram	27
Parts List.....	28
Replacement Parts	29
Limited Warranty.....	30

Technical Specifications

Property	Specification
Model	DH420
Displacement	420cc
Bore	3.54 inches
Stroke	2.60 inches
Oil Capacity	0.29 gal.(1.1L)
Net Weight	68.89 lbs.

Important Safety Information

SAFETY REFERENCES

The safety alert symbol  is used to identify safety information about hazards that can result in personal injury. A signal word (DANGER, WARNING, or CAUTION) is used with the alert symbol to indicate the likelihood and the potential severity of injury. In addition, a hazard symbol maybe used to represent the type of hazard.



DANGER: indicates a hazard which, if not avoided, will result in death or serious injury.



WARNING: indicates a hazard which, if not avoided, could result in death or serious injury.



CAUTION: indicates a hazard which, if not avoided, might result in minor or moderate injury.



CAUTION: when used without the alert symbol, indicates a situation that could result in damage to the engine.



This manual contains safety information to make you aware of the hazards and risks associated with engines, and how to avoid them. Because we do not necessarily know what equipment this engine will power, it is important that you read and understand these instructions and the instructions for the equipment this engine powers.

WARNING

We do not approve or authorize the use of these engines on 3-wheel All Terrain Vehicles (ATVs), motor bikes, fun/recreational go-karts, aircraft products or vehicles intended for use in competitive events. Use of these engines in such applications could result in property damage, serious injury (including paralysis), or even death.

WARNING

The engine exhaust from this product contains chemicals known to the State of California to cause cancer, birth defects, or other reproductive harm.

WARNING

WORK AREA SAFETY

- Inspect the work area before each use. Keep work area clean, dry, free of clutter, and well-lit. Cluttered, wet, or dark work areas can result in injury. Using the engine in confined work areas may put you dangerously close to other cutting tools and rotating parts.
- Do not allow the engine to come into contact with an electrical source. The engine is not insulated and contact will cause electrical shock.
- Keep children and bystanders away from the work area while operating the tool. Do not allow children to handle the engine.
- Be aware of all power lines, electrical circuits, water pipes, and other mechanical hazards in your work area. Some of these hazards may be hidden from your view and may cause personal injury and/or property damage if contacted.

WARNING

PERSONAL SAFETY

- Stay alert, watch what you are doing, and use common sense when operating the engine. Do not use the engine while you are tired or under the influence of drugs, alcohol, or medication. A moment of inattention while operating the tool may result in serious personal injury.
- Dress properly. Do not wear loose clothing, dangling objects, or jewelry. Keep your hair, clothing and gloves away from moving parts. Loose clothes, jewelry, or long hair can be caught in moving parts. Air vents on the tool often cover moving parts and should be avoided.
- Wear the proper personal protective equipment when necessary. Use ANSI Z87.1 compliant safety goggles (not safety glasses) with side shields, or when needed, a face shield. Use a dust mask in dusty work conditions. Also use non-skid safety shoes, hardhat, gloves, dust collection systems, and hearing protection when appropriate. This applies to all persons in the work area.
- Do not overreach. Keep proper footing and balance at all times.
- Remove keys or wrenches before connecting the tool to an air supply, power supply, or turning on the tool. A wrench or key that is left attached to a rotating part of the tool may cause personal injury.
- Secure the work with clamps or a vise instead of your hand when practical. This safety precaution allows for proper tool operation using both hands.

CAUTION

ENGINE USE AND CARE

- This engine is shipped from us without oil. If you start the engine without oil, the engine will be damaged beyond repair and will not be covered under warranty.
- Do not force the engine. Products are safer and do a better job when used in the manner for which they are designed. Plan your work and use the correct product for the job.
- Check for damaged parts before each use. Carefully check that the engine will operate properly

and perform its intended function. Replace damaged or worn parts immediately. Never operate the engine with a damaged part.

Specific Operation Warnings

WARNING



Gasoline and its vapors are extremely flammable and explosive.



Fire or an explosion can cause severe burns or death.

When Adding Fuel

- Turn engine 'off' and let it cool at least 2 minutes before removing the fuel filler cap.
- Fill the fuel tank outdoors or in a well-ventilated area.
- Do not overfill the fuel tank.
- Keep gasoline away from sparks, open flames, pilot lights, heat, and other ignition sources.
- Check the fuel lines, the tank, the cap, and the fittings frequently for cracks or leaks. Replace if necessary.

When Starting the Engine

- Make sure the spark plug, muffler, fuel filler cap, and air cleaner are in place.
- Do not crank the engine with the spark plug removed.
- If fuel spills, wait until it evaporates before starting the engine.
- If the engine floods, set the choke to the 'open/run' position, place throttle in 'fast', and crank until the engine starts.

When Operating Equipment

- Do not choke the carburetor to stop the engine.

When Transporting Equipment

- Transport with the fuel tank EMPTY.

When Storing Gasoline or Equipment with Fuel in the Tank

- Store away from furnaces, stoves, water heaters, or other appliances that have a pilot light or other ignition source because they can ignite gasoline vapors.

WARNING



Starting the engine creates sparking.



Sparking can ignite nearby flammable gases.

Explosion and fire could result.

- If there is a natural or LP gas leakage in the area, do not start the engine.
- Do not use pressurized starting fluids because vapors are flammable.

WARNING

- Rapid retraction of starter cord (kickback) will pull hand and arm toward engine faster than you can let go. Broken bones, fractures, bruises or sprains could result.
- When starting engine, pull cord slowly until resistance is felt, then pull rapidly.
- Direct coupled equipment components such as, but not limited to, blades, impellers, pulleys, sprockets, etc., must be securely attached.

WARNING

- Rotating parts can contact or entangle hands, feet, hair, clothing, or accessories.
- Traumatic amputation or severe laceration can result.
- Operate the equipment with guards in place. Keep hands and feet away from rotating parts.
- Tie up long hair and remove jewelry.
- Do not wear loose-fitting clothing, dangling drawstrings, or items that could become caught.

WARNING

- Engines give off carbon monoxide, an odorless, colorless, poison gas.
- Breathing carbon monoxide can cause nausea, fainting or death.
- Start and run the engine outdoors.
- Do not start or run engine in an enclosed area, even if doors or windows are open.

WARNING

- Running engines produce heat. Engine parts, especially mufflers, become extremely hot.
- Severe thermal burns can occur on contact.
- Combustible debris, such as leaves, grass, brush, etc., can catch fire.
- Allow muffler, engine cylinder and fins to cool before touching.
- Remove accumulated debris from muffler area and cylinder area.
- Install and maintain in working order a spark arrester before using equipment on forest-covered, grass-covered, brush-covered unimproved land. The state of California requires this. Other states may have similar laws. Federal laws apply on federal land.

Safety Labels



Main Engine Parts

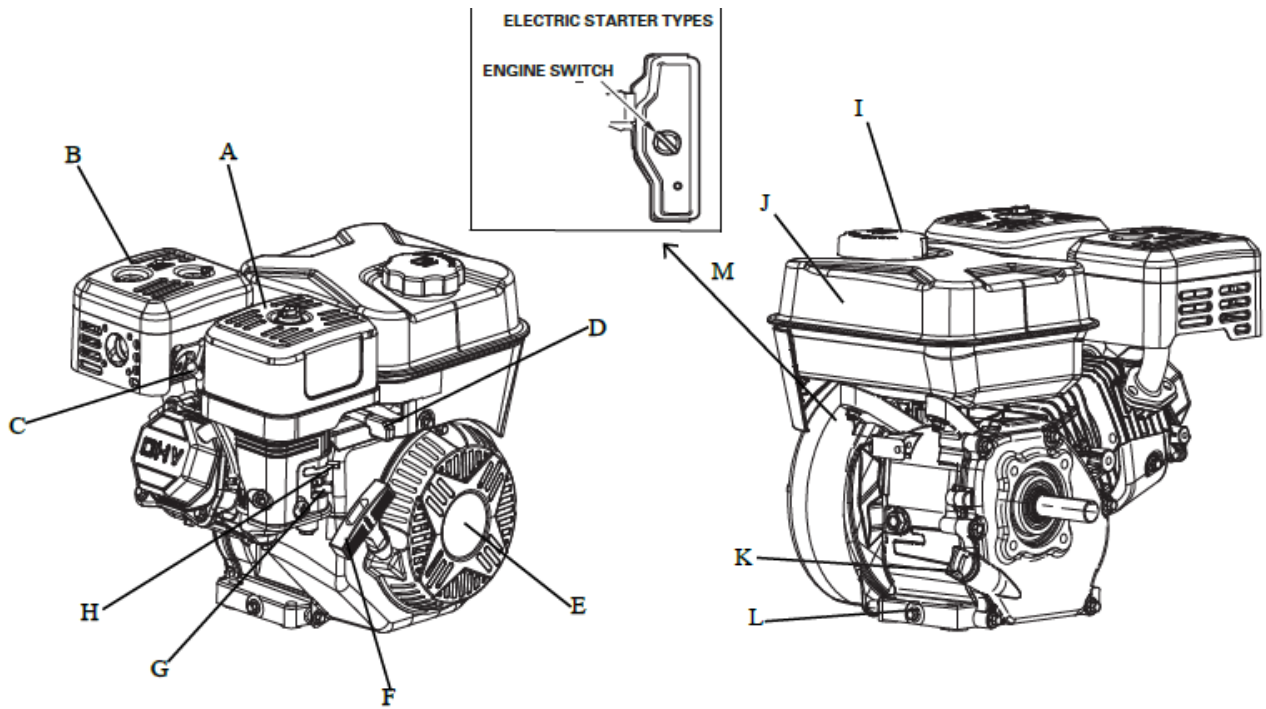

Reference	Subassembly
A	Air Cleaner
B	Muffler
C	Spark Plug
D	Throttle Lever
E	Recoil Starter
F	Starting Handle
G	Fuel Shut-off
H	Choke Lever
I	Fuel Filler Cap
J	Fuel Tank
K	Oil Dipstick
L	Drain Plug
M	Control Box

Before Each Use

⚠WARNING

Improperly maintaining this engine, or failure to correct a problem before operation, can cause a malfunction in which you can be seriously hurt or killed. Always perform a pre-operation inspection before each operation, and correct any problem.

Pre-Operation Checks

For your safety, and to maximize the service life of your equipment, it is very important to take a few moments before you operate the engine to check its condition. Be sure to take care of any problem you find, or have your servicing dealer correct it, before you operate the engine.

Before beginning your pre-operation checks, be sure the engine is level and the engine switch is in the OFF position. Always check the following items before you start the engine:

Check the General Condition of the Engine

1. Look around and underneath the engine for signs of oil or gasoline leaks.
2. Remove any excessive dirt or debris, especially around the muffler and recoil starter.
3. Look for signs of damage.
4. Check that all shields and covers are in place, and all nuts, bolts, and screws are tightened.

Check the Engine

1. Check the fuel level. Starting with a full tank will help to eliminate or reduce operating interruptions for refueling.
2. Check the engine oil level. Running the engine with a low oil level can cause engine damage.
3. The Oil Alert system will automatically stop the engine before the oil level falls below safe limits. However, to avoid the inconvenience of an unexpected shutdown, always check the engine oil level before startup.
4. Check the air filter element. A dirty air filter element will restrict air flow to the carburetor, reducing engine performance.
5. Check the equipment powered by this engine.

Review the instructions provided with the equipment powered by this engine for any precautions and procedures that should be followed before engine start-up.

Operating Instructions

⚠WARNING

- Gasoline and its vapors are extremely flammable and explosive.
- Fire or explosion can cause severe burns or death.
- Engines give off carbon monoxide, an odorless colorless, poison gas. Breathing carbon monoxide can cause nausea, fainting or death.
- Unintentional sparking can result in fire or electric shock.
- Unintentional start-up can result in entanglement, traumatic amputation, or laceration.

⚠CAUTION

HIGH ALTITUDE OPERATION

Operating at an altitude of greater than 2000 feet (610 meters) may affect your engines performance, fuel consumption, and emissions. To remain emissions compliant and improve engine performance at higher altitudes, a high-altitude kit is required. A high altitude kit includes a carburetor jet resized to help correct air / fuel mixture at altitude. To order a high altitude kit or if you have additional questions, go to www.northerntool.com or contact us at 1-866-443-2576. Please note, engines with the high-altitude kit installed operated at lower altitudes could cause severe engine damage and affect emissions compliance. When modified, a tag or decal should be added to the product stating that a high-altitude kit was installed and to remind you to re-service the carburetor (re-jet) when operating in lower altitude environments.

Starting the Engine

1. Move the fuel shut-off to the ON position.

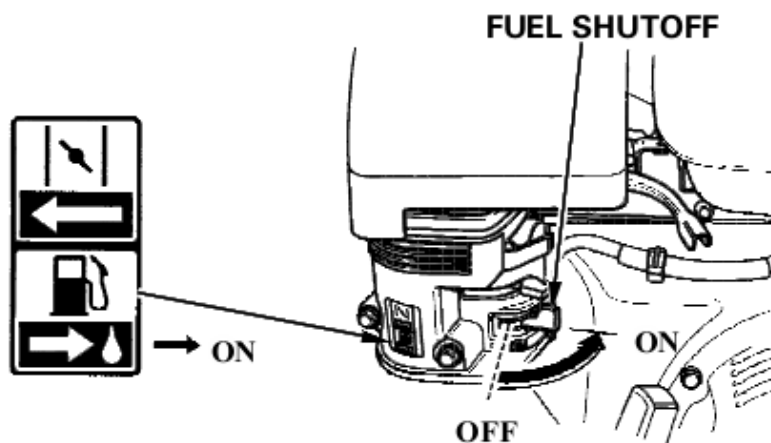

- To start a cold engine, move the choke lever to the CHOKE position.
To restart a warm engine, leave the choke lever in the RUN position.

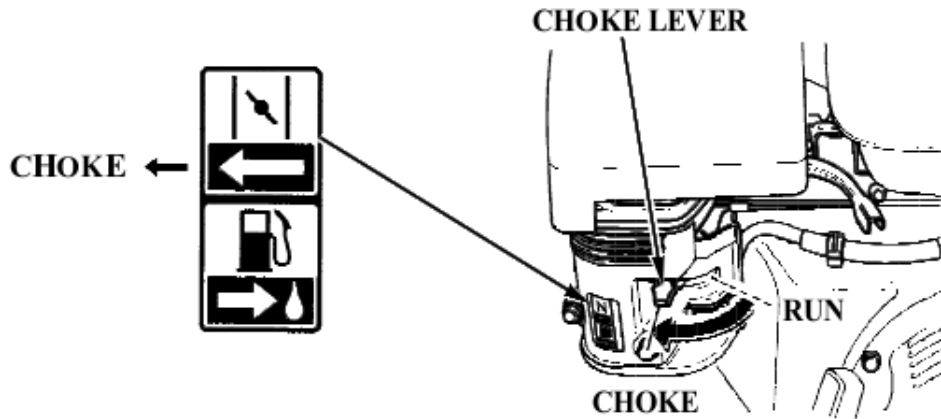

- Move the throttle lever away from the MIN. position, about 1/3 of the way toward the MAX. position.

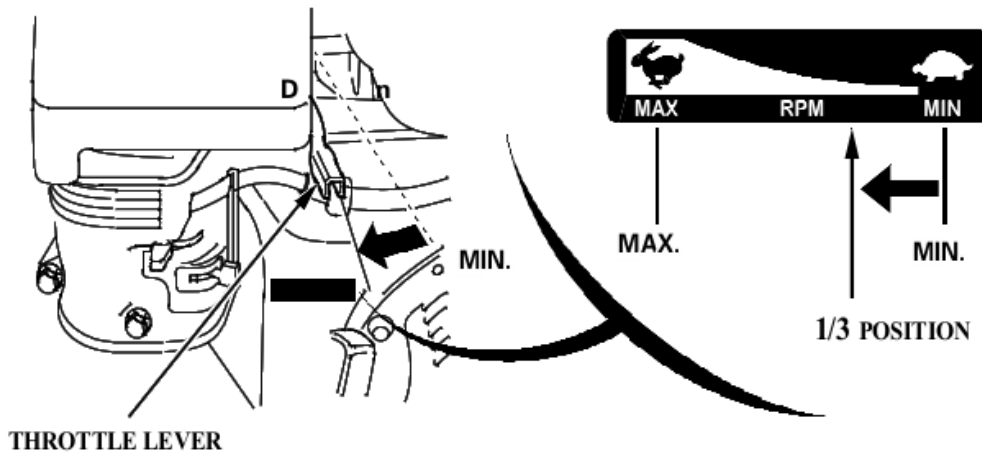

- Turn the engine switch to the ON position.

ELECTRIC STARTER TYPES

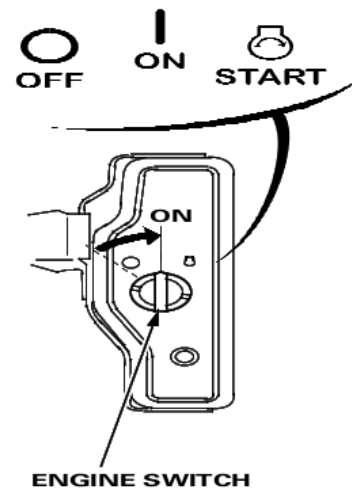

**EXCEPT ELECTRIC
STARTER TYPES**

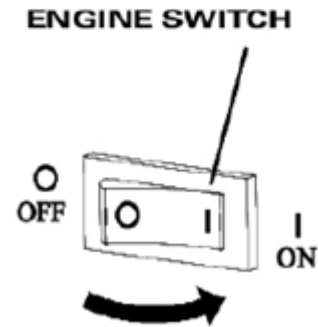

5. Operate the starter.

Recoil Start

Pull the starter grip lightly until you feel resistance, then pull briskly in the direction of the arrow as shown below. Return the starter grip gently.

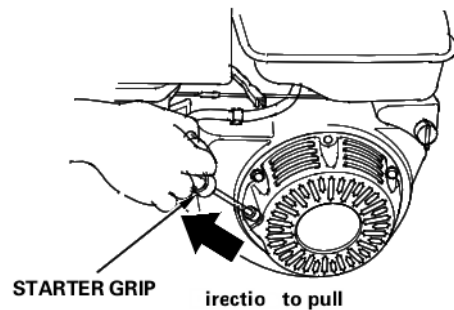

⚠WARNING

Do not allow the starter grip to snap back against the engine. Return it gently to prevent damage to the starter.

Electric Starter

Turn the key to the START position, and hold it there until the engine starts. If the engine fails to start within 5 seconds, release the key, and wait at least 10 seconds before operating the starter again.

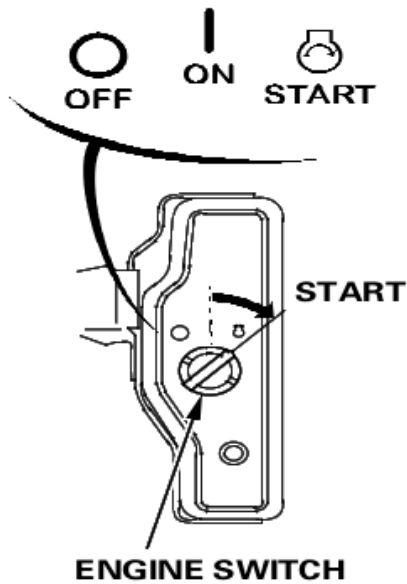

When the engine starts, release the key, allowing it to return to the ON position.

⚠WARNING

Using the electric starter for more than 5 seconds at a time will overheat the starter motor and can damage it.

- If the choke lever has been moved to the CHOKE position to start the engine, gradually move it to the RUN position as the engine warms up.

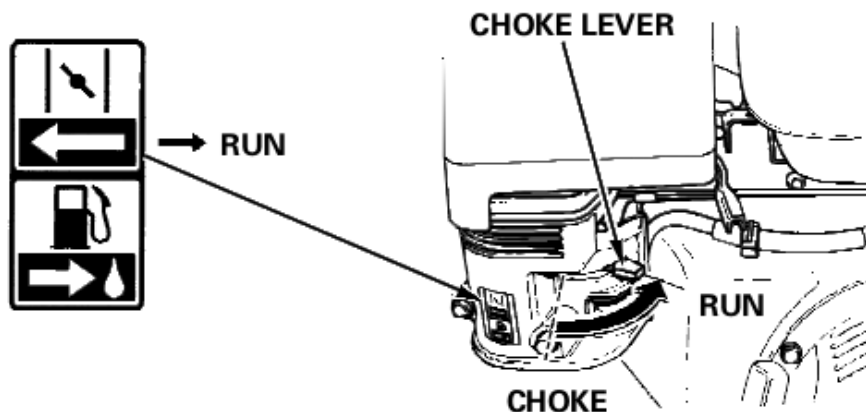

Stopping the Engine

To stop the engine in an emergency, simply turn the engine switch to the OFF position. Under normal conditions, use the following procedure. Refer to the instructions provided by the equipment manufacturer.

1. Move the throttle lever to the MIN. position.

Some engine applications use a remote-mounted throttle control rather than the engine-mounted throttle lever shown here.

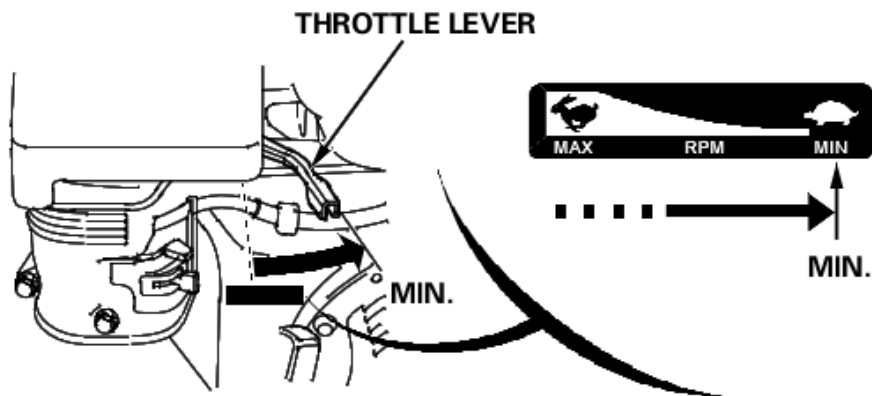

2. Turn the engine switch to the OFF position.

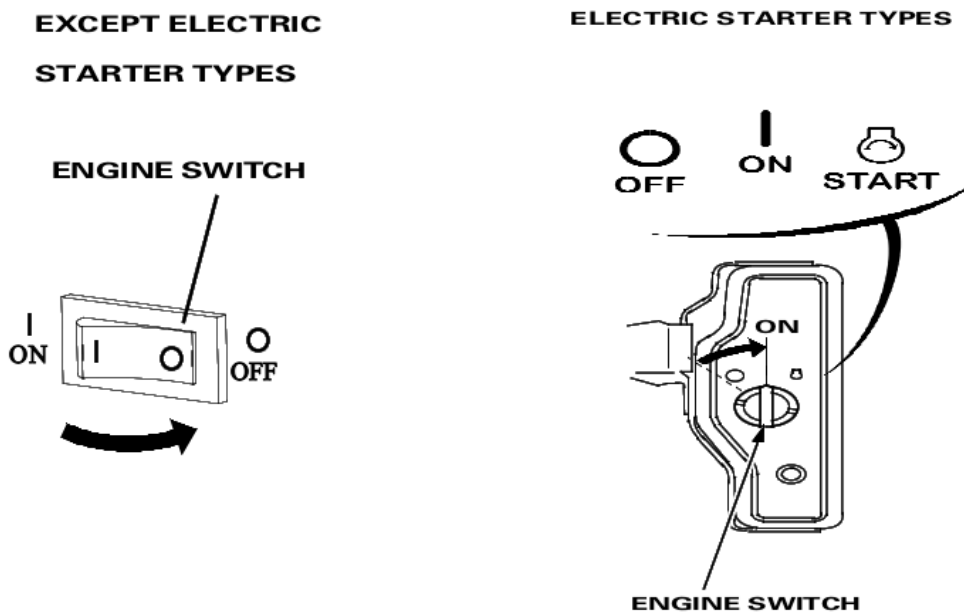

3. Turn the fuel shutoff to the OFF position.

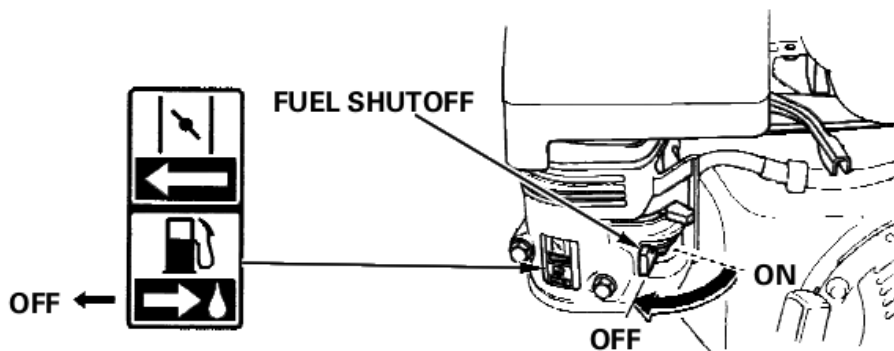

Setting Engine Speed

Position the throttle lever for the desired engine speed.

Some engine applications use a remote-mounted throttle control rather than the engine-mounted throttle lever shown here. Refer to the instructions provided by the equipment manufacturer.

For engine speed recommendations, refer to the instructions provided with the equipment powered by this engine.

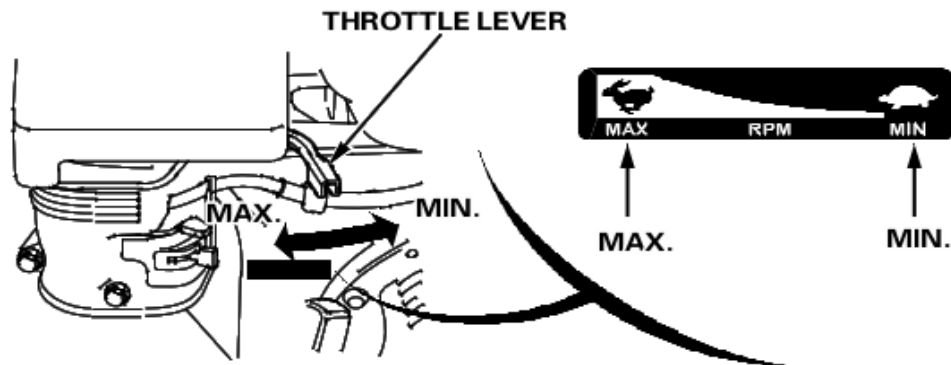

Maintenance

⚠WARNING

All the components used to build this engine must remain in place for proper operation.

Use only original equipment replacement parts. Other parts may not perform as well, may damage the unit, and may result in injury.

In addition, use of other parts may void your warranty. We recommend that you use an authorized service center for all maintenance and service of the engine and engine parts.

Before performing adjustments or repairs

Disconnect the spark plug wire and keep it away from the spark plug.

- Use only correct tools.
- Do not tamper with governor spring, links or other parts to increase engine speed.
- Replacement parts must be the same and installed in the same position as the original parts.
- Do not strike the flywheel with a hammer or hard object because the flywheel may later shatter during operation.

When Testing for Spark

Use an approved spark plug tester.

Maintenance Schedule

REGULAR SERVICE PERIOD (3) Perform at every indicated month or operating hour interval, whichever comes first.		Each Use	First Month or 20 Hrs	Every 3 Months or 50 Hrs	Every 6 Months or 100 Hrs	Every Year or 300 Hrs
Item						
Engine Oil	Check level	<input type="radio"/>				
	Change		<input type="radio"/>		<input type="radio"/>	
Air Cleaner	Check	<input type="radio"/>				
	Clean			<input type="radio"/> (1)	<input type="radio"/> (1)	
	Replace					<input type="radio"/>
Sediment Cup	Clean				<input type="radio"/>	
Spark Plug	Check-adjust				<input type="radio"/>	
	Replace					<input type="radio"/>
Spark Arrester	Clean				<input type="radio"/>	
Idle Speed	Check-adjust					<input type="radio"/> (2)
Valve Clearance	Check-adjust					<input type="radio"/> (2)
Combustion Chamber	Clean	After every 500 Hrs.(2)				
Fuel Tank & Filter	Clean				<input type="radio"/> (2)	
Fuel Tube	Check	Every 2 years (Replace if necessary) (2)				

Note:

- (1) Service more frequently when used in dusty areas.
- (2) We recommend that you see an authorized service center for all maintenance and service of the engine and engine parts. Use only our genuine parts.
- (3) For commercial use, log hours of operation to determine proper maintenance intervals.

Engine Oil

Oil is a major factor affecting performance and service life. Use 4-stroke automotive detergent oil.

Recommended Oil

Use 4-stroke motor oil that meets or exceeds the requirements for API service category SJ or later (or equivalent). Always check the API service label on the oil container to be sure it includes the letters SJ or later (or equivalent).

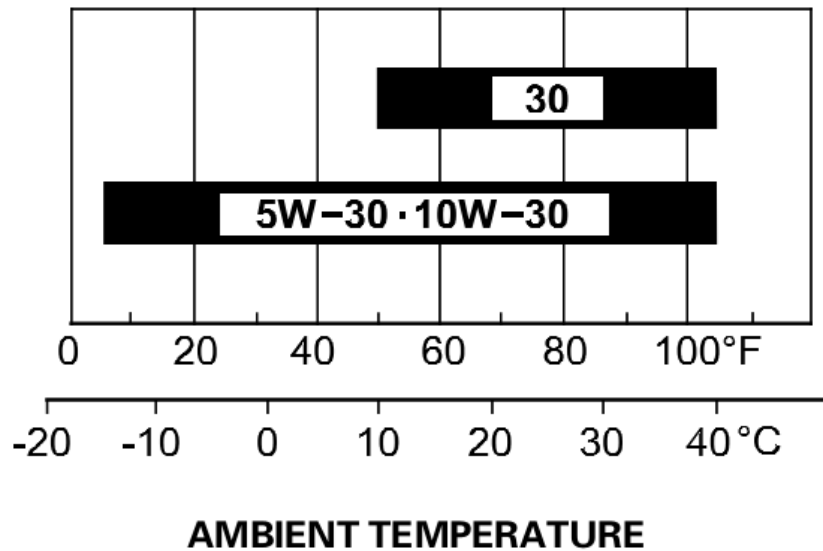

SAE 10W-30 is recommended for general use. Other viscosities shown in the chart may be used when the average temperature in your area is within the indicated range.

Before Adding or Checking the Oil

- Place engine on a level surface.
- Clean the oil fill area of any debris.

How to Check/Add Oil

⚠WARNING

Gasoline is highly flammable and explosive, and you can be burned or seriously injured when refueling.

- Stop engine and keep heat, sparks, and flame away.
- Refuel only outdoors.
- Wipe up spills immediately.

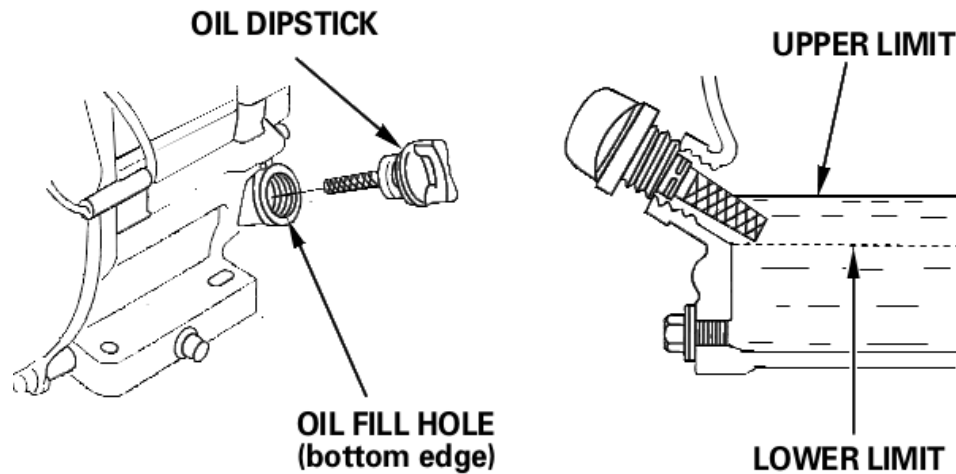

1. Remove the oil dipstick and wipe with a clean cloth.
2. Insert the oil dipstick into the filler neck without screwing it in.
3. Remove the oil dipstick and check the oil level. Make sure the oil is at the FULL mark on the dipstick.
4. If the oil level is near or below the lower limit mark on the dipstick, fill with the recommended oil. Do not overfill. After adding oil, wait one minute and then recheck the oil level.
5. Replace and tighten the oil dipstick.

Fuel Recommendations

Unleaded gasoline: U.S. Pump octane rating 86 or higher. Except U.S. Research octane rating 91 or higher. Pump octane rating 86 or higher.

This engine is certified to operate on unleaded gasoline with a pump octane rating of 86 or higher (a research octane rating of 91 or higher).

Refuel in a well-ventilated area with the engine stopped. If the engine has been running, allow it to cool first. Never refuel the engine inside a building where gasoline fumes may reach flames or sparks.

You may use unleaded gasoline containing no more than 10% ethanol (E10) or 5% methanol by volume. In addition, methanol must contain co solvents and corrosion inhibitors. Use of fuels with content of ethanol or methanol greater than shown above may cause starting and/or performance problems. It may also damage metal, rubber, and plastic parts of the fuel system. Engine damage or performance problems that result from using a fuel with percentages of ethanol or methanol greater than shown above are not covered under warranty.

How to Add Fuel

⚠WARNING

Gasoline and its vapors are extremely flammable and explosive.
Fire or explosion can cause severe burns or death.

For refueling, refer to the manufacturer's instructions provided with the equipment. See the following for a Powerhorse supplied standard fuel tank refueling instruction

1. With the engine stopped and on a level surface, remove the fuel filler cap and check the fuel level. Refill the tank if the fuel level is low.

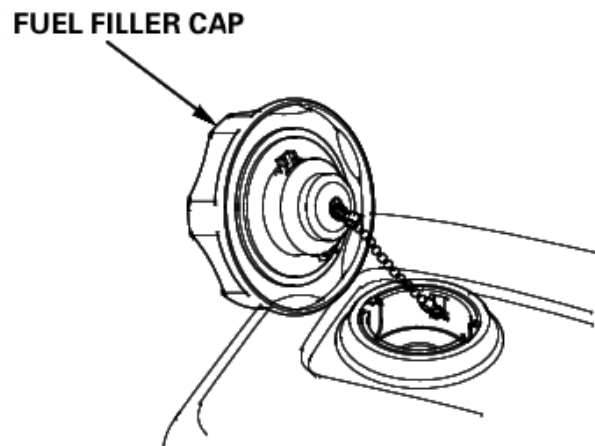

2. Add fuel to the bottom of the maximum fuel level limit of the fuel tank. Do not overfill. Wipe up spilled fuel before starting the engine.

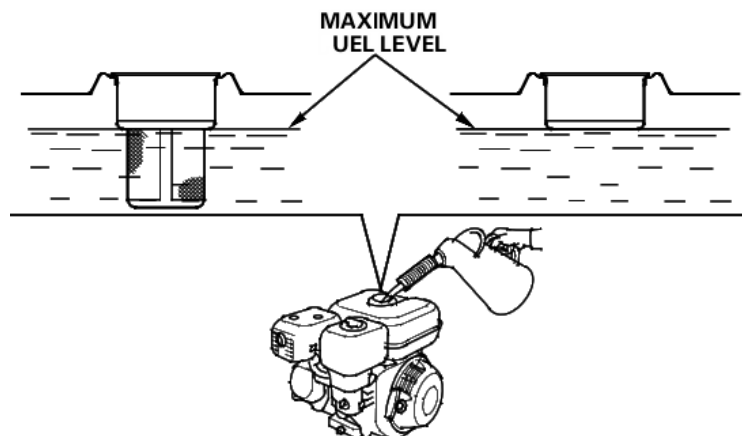

Carburetor Adjustment

Never make adjustments to the carburetor. The carburetor was set at the factory to operate efficiently under most conditions. However, if adjustments are required, see any our Authorized Dealer for service.

⚠ CAUTION

The manufacturer of the equipment on which this engine is installed specifies the top speed at which the engine will be operated. Do not exceed this speed.

How to Replace the Spark Plug

If the engine has been running, let it cool before servicing the spark plug.

For good performance, the spark plug must be properly gapped and free of deposits.

1. Disconnect the spark plug cap, and remove any dirt from around the spark plug area.
2. Remove the spark plug with a 13/16-inch spark plug wrench.
3. Visually inspect the spark plug. Replace it if damaged or badly fouled, if the sealing washer is in poor condition, or if the electrode is worn.
4. Measure the spark plug electrode gap with a wire-type feeler gauge. Correct the gap, if necessary, by carefully bending the side electrode.
The gap should be: 0.7-0.8 mm (0.028-0.031 in)
5. Install the spark plug carefully, by hand, to avoid cross-threading.
6. After the spark plug is seated, tighten with a 13/16-inch spark plug wrench to compress the sealing washer.

When installing a new spark plug, tighten 1/2 turn after the spark plug seats to compress the washer.

When reinstalling the original spark plug, tighten 1/8 1/4 turn after the spark plug seats to compress the washer.

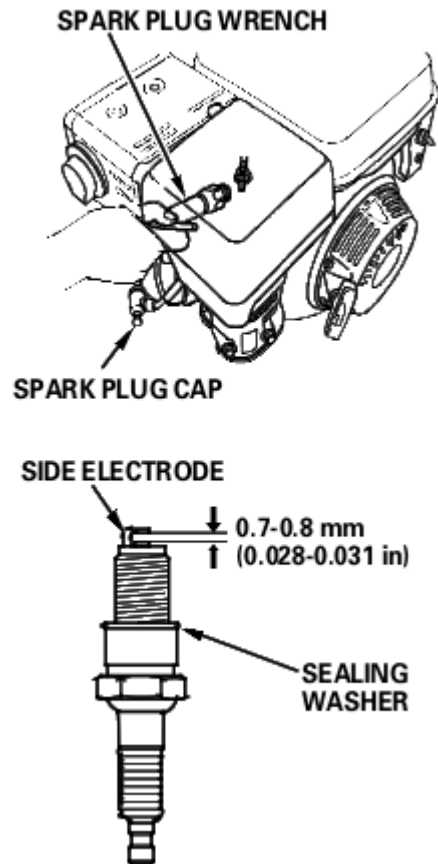

⚠ CAUTION

A loose spark plug can overheat and damage the engine. Over tightening the spark plug can damage the threads in the cylinder head.

7. Attach the spark plug cap to the spark plug.

Inspect Muffler and Spark Arrester

⚠ WARNING

Running engines produce heat. Engine parts, especially muffler, become extremely hot.

Severe thermal burns can occur on contact.

Combustible debris, such as leaves, grass, brush, etc. can catch fire.

1. Allow muffler, engine cylinder, and fins to cool before touching.
2. Remove accumulated debris from muffler area and cylinder area.
3. Replacement parts must be the same and installed in the same position as the original parts or fire could result.

Sediment Cup

Cleaning

⚠WARNING

Gasoline is highly flammable and explosive, and you can be burned or seriously injured when handling fuel

- Stop engine and keep heat, sparks, and flame away.
- Handle fuel only outdoors.
- Wipe up spills immediately.

1. Move the fuel shut-off to the OFF position, then remove the sediment cup and O-ring.
2. Wash the sediment cup in non-flammable solvent, and dry it thoroughly.
3. Place the O-ring in the fuel shut-off, and install the sediment cup. Tighten it securely.

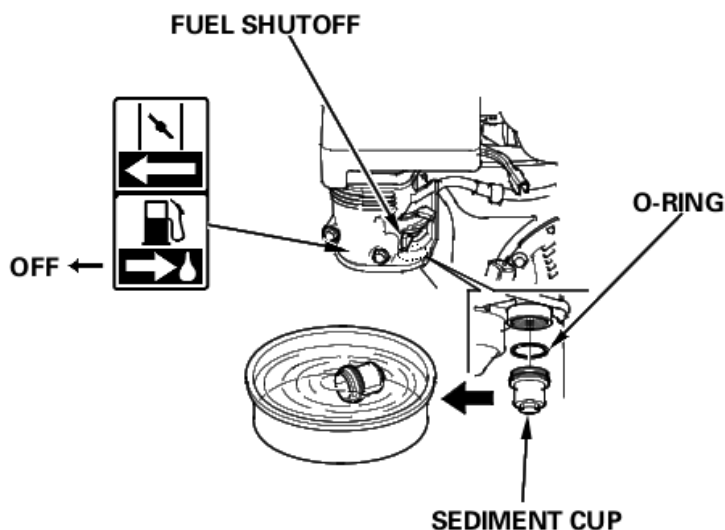

4. Move the fuel shut-off to the ON position, and check for leaks. Replace the O-ring if there is any leakage.

How to Service the Air Filter (figure 1)

1. Remove the air cleaner outside cover (A). Be careful to prevent dirt and debris from falling into the air cleaner assembly.
2. Separate the Air Filter (A) from the Air Filter Housing (B).

3. Inspect the air filter. Clean dirty air filter with warm water and mild soap. Allow air filter to dry thoroughly before re-installation

4. Install the air filter assembly onto the carburetor and secure with screw.

Note: Do not use pressurized air or solvents to clean the filter. Pressurized air can damage the filter and solvents will dissolve the filter.

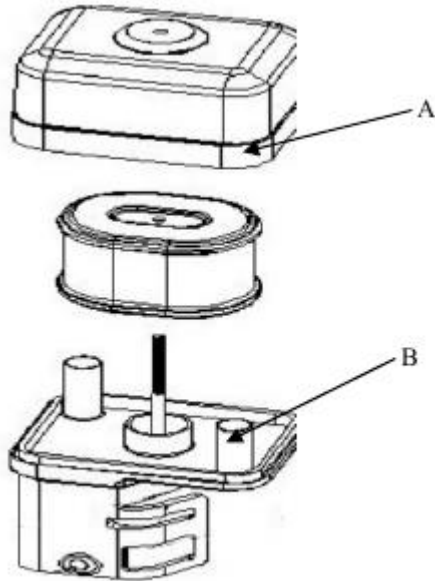

figure 1

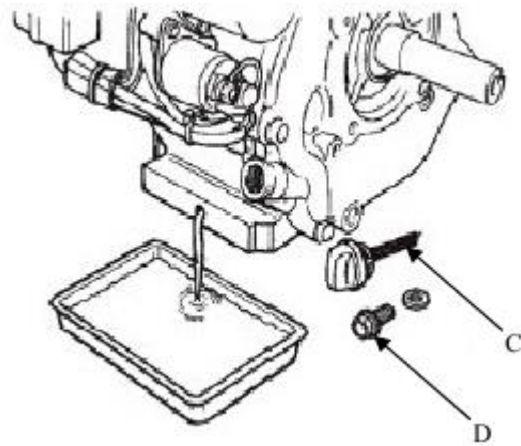

figure 2

How to Remove Oil

⚠WARNING

When you drain the oil from the oil drain plug, the fuel tank must be empty or fuel can leak out and result in fire or explosion. To empty the fuel tank, run engine until it stops from lack of fuel.

⚠CAUTION

Used oil is a hazardous waste product and must be disposed of properly. Do not discard with household waste. Check with your local authorities, service center, or dealer for safe disposal/recycling facilities.

Removing Oil

The oil must be drained from the Oil Drain Plug. (See figure 2.)

1. Remove the dipstick (C)
2. Place an approved container below the oil drain plug.
3. Remove the Oil drain plug (D) and allow oil to drain into the approved container.
4. Install Oil drain plug (D) and wrench tighten.

How to Service the Fuse-see figure 3 (if applicable)

⚠WARNING

Never use a fuse with a rating greater than the one originally equipped with the engine. Serious damage to the electrical system or a fire could result.

1. Remove the 6x12mm screw from the rear cover of the engine switch box.
2. Remove the fuse cover, then pull out and inspect the fuse.
3. Reinstall the rear cover. Install the 6x12mm screw and tighten.

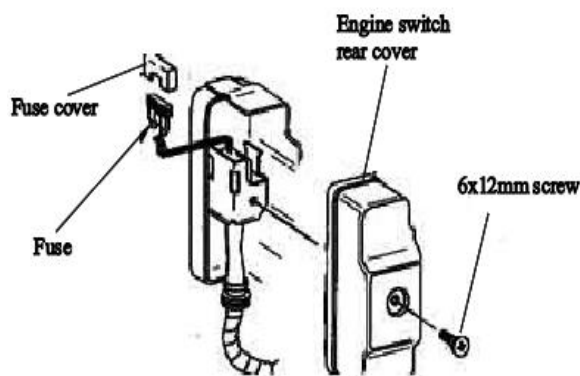

figure3

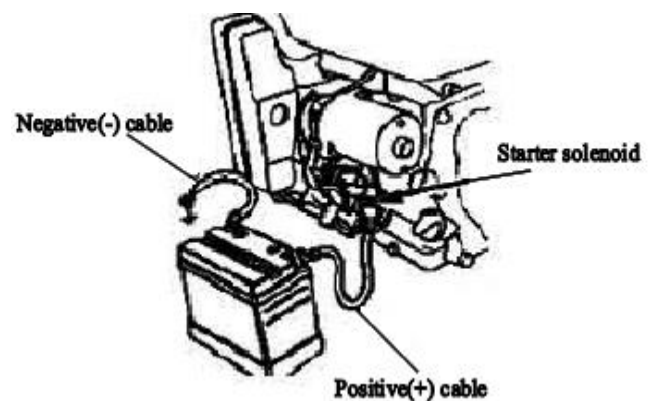

figure4

How to Service the Battery -see figure 4 (if applicable)

⚠WARNING

Be careful not to connect the battery in reverse polarity, as this will short circuit the battery charging system.

Note: Use a 12-volt battery with an ampere-hour rating of at least 18 Ah.

1. Connect the positive (+) cable to the starter solenoid terminal.
2. Connect the negative (-) cable to an engine mounting bolt or other good engine ground connection.
3. Connect the positive (+) cable to the positive (+) terminal.
4. Connect the negative (-) cable to the negative (-) terminal.

Troubleshooting

⚠WARNING

Do not crank engine with spark plug removed.

Failure	Possible Cause	Corrective Action
If engine will not start	Out of fuel	If engine is cold, ensure choke lever is set correctly. Add fuel.
	Engine flooded	Set choke lever to open/run position.
	Dirty or faulty spark plug/engine fails to produce spark	Remove spark plug and clean it. Check the spacing on the electrode and set the gap to the correct dimension. See Maintenance Section. If plug is damaged, replace with a new spark plug. Ensure the spark plug is installed and wire is connected.

Storage

⚠WARNING

When storing fuel or equipment with fuel in tank

Store away from furnaces, stoves, water heaters, or other appliances that have a pilot light or other ignition source because they can ignite vapors.

When transporting equipment

Transport with fuel tank EMPTY or with fuel shut-off valve OFF.

The following precautions should be taken if storing your engine for a period exceeding 30 days, or for seasonal storage.

- While engine is still warm, change oil.
- Clean engine of surface debris, chaff or grass.
- Drain all fuel from fuel tank into proper receptacle for storage.
- Remove spark plug. Place 1 teaspoon or 5 ml. of oil into spark plug hole.
- Pull starter rope slowly 8-10 times to properly coat the cylinder bore and piston for storage.
- Replace spark plug and tighten. Any residual oil may burn off in subsequent starts. This may result in white smoke emission from muffler.

Note: Storing or transporting with the spark plug down will result in hard starting and/or engine smoking.

- Store in a clean dry area.
- When removing unit from storage, only use fresh gasoline. Perform operation checks (see maintenance schedule) before starting engine.

** Engine power will decrease 3.5% for each 1,000 feet (300 meters) above sea level and 1% for each 10°F (5.6°C) above 77°F (25°C). The engine will operate satisfactorily at an angle up to 15°. Refer to the equipment operator's manual for safe allowable operating limits on slopes.

We recommend that you see an authorized service center for all maintenance and service of the engine and engine parts. Use only our genuine parts.

Parts Diagram

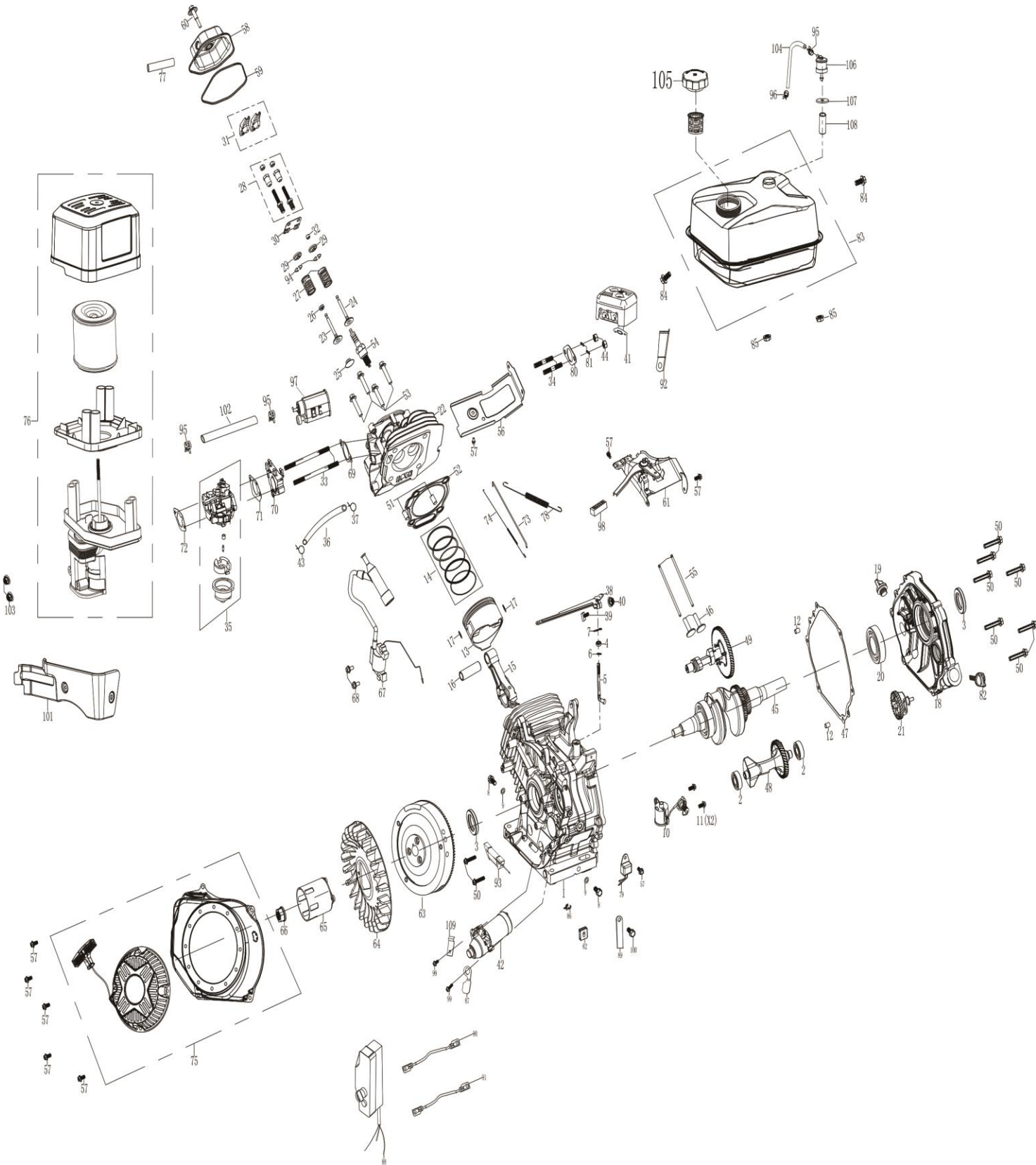

Parts List

Ref	Code	Part Description	Qty
1	260213	CRANKCASE	1
2	93029	BALL BEARING	2
3	93511	OIL SEAL	2
4	93516	SEAL, GOVERNOR ARM SHAFT	1
5	263901	SHAFT, GOVERNOR ARM	1
6	96806	WASHER, GOVERNOR ARM SHAFT	1
7	263902	PIN, LOCK	1
8	91817	BOLT, DRAIN PLUG	2
9	94004	WASHER, DRAIN PLUG	2
10	265102	SWITCH ASSEMBLY, OIL LEVEL	1
11	91329	BOLT M6X16	2
12	240901	DOWEL PIN, CASECOVER	2
13	261205	PISTON	1
14	261604	SCRAPER RING SET, PISTON	1
15	261503	ROD ASSEMBLY, CONNECTING	1
16	265501	PIN, PISTON	1
17	261301	CLIP, PISTON	2
18	260102	COVER ASSEMBLY, CRANKCASE	1
19	261401	OIL PLUG	1
20	93030	BALL BEARING	1
21	264301	GOVERNOR ASSEMBLY	1
22	261008	CYLINDER HEAD	1
23	261702	VALVE, IN	1
24	265903	VALVE EXHAUST	1
25	261807	RETURNER, INTAKE VALVE	1
26	93513	OIL SEAL, VALVE	1
27	266002	SPRING, VALVE	2
28	91818	ADJUSTER ROCKER ARM	2
29	261805	SEAT, VALVE SPRING,EX	2
30	262202	PLATE, PUSH ROD GUIDE	1
31	262101	ROCKER ASSY	2
32	261806	ROTATOR	1
33	91013	BOLT, STUD	2
34	91015	BOLT, STUD	2
35	262844	CARBURETOR ASSEMBLY	1
36	95413	FUEL LINE	1

Ref	Code	Part Description	Qty
56	260502	SHROUD	1
57	91325	BOLT M6X12	11
58	261104	COVER COMP, CYLINDER HEAD	1
59	96075	PACKING, HEADCOVER	1
60	91819	LOCK BOLT	1
61	264407	SHROUD ASSY, UPPER	1
62	269901	RUBBER, STARTER ASSY	1
63	260402	FLYWHEEL ASSEMBLY	1
64	264601	FAN, RECOIL STARTER	1
65	264501	PULLEY, STARTER	1
66	90004	NUT	1
67	97518	IGNITION COIL ASSY	1
68	91331	BOLT M6X25	2
69	96079	PACKING, INTAKE	1
70	262301	INSULATOR, CARBURETOR	1
71	96082	PACKING, CARBURETOR	1
72	94227	SPACER, CARBURETOR	1
73	262701	ROD, GOVERNOR	1
74	264201	SPRING, THROTTLE RETURN	1
75	264724-048	RECOIL STARTER ASSEMBLY	1
76	262921	AIR CLEANER ASSEMBLY	1
77	95605	TUBE, BREATHER	1
78	264103	SPRING, GOVERNOR	1
79	245104	AMPLIFIER	1
80	96083	PACKING, EXHAUST	1
81	94206	SPRING WASHER	2
82	265601	DIPSTICK	1
83	263120-048	FUEL TANK ASSEMBLY	1
84	91346	BOLT M8X25	2
85	90018	NUT M8	2
86	260801	CLIP	1
87	269902	CLAMPER CORD A	1
88	265028-048	CONTROL BOX ASSEMBLY	1
89	599601	CLIP, WIRE HARNESS	1
90	512017	NEGATIVE LEAD	1
91	512007	POSITIVE LEAD	1

Ref	Code	Part Description	Qty
37	94403	CLIP, FUEL LINE 7.5	1
38	264001	GOVERNOR ARM	1
39	91822	BOLT, GOVERNOR ARM	1
40	90016	NUT M6	1
41	263718	MUFFLER COMP	1
42	97406	STARTING MOTOR ASSEMBLY	1
43	94404	CLIP, FUEL LINE 8	1
44	90011	NUT M8	2
45	260339	CRANKSHAFT ASSEMBLY	1
46	266101	LIFTER, VALVE	2
47	96073	PACKING, CASECOVER	1
48	260301	BALANCING SHAFT	1
49	262003	CAMSHAFT ASSEMBLY	1
50	91348	BOLT M8X35	9
51	260901	PIN, DOWEL	2
52	96090	GASKET, CYLINDER HEAD	1
53	91321	BOLT M10X80	4
54	97108	SPARK PULG	1
55	261901	ROD, PUSH	2

Ref	Code	Part Description	Qty
92	262603	BRACKET	1
93	97210	CHARGE COIL	1
94	260802	LOCKING FLAPS	4
95	94409	CLIP, FUEL LINE 9.5	3
96	94408	CLIP, FUEL LINE 10	1
97	263801	CARBON TANK COMP SPEED REGULATING HANDLE	1
98	244412	SPEED REGULATING HANDLE	1
99	91333	BOLT M6X28	2
100	91340	BOLT M6X8	1
101	263004	CARTON	1
102	95008	CONNECTING PIPE	1
103	90030	NUT M6	2
104	95103	CONNECTING PIPE	1
105	243609	FUEL TANK CAP COMP	1
106	546606	ONE-WAY VALVE ASSEMBLY	1
107	550605	PACKING WASHER, ONE-WAY VALVE	1
108	95903	VENTILATION TUBE PROTECTOR	1
109	249901	CLAMPER CORD A	1

Replacement Parts

- For replacement parts and technical questions, please call Customer Service at **1-866-443-2576**.
- Not all product components are available for replacement. The illustrations provided are a convenient reference to the location and position of parts in the assembly sequence.
- When ordering parts, the following information will be required: item description, item model number, item serial number/item lot date code, and the replacement part reference number.
- The distributor reserves the rights to make design changes and improvements to product lines and manuals without notice.

Limited Warranty

Northern Tool and Equipment Company, Inc. ("We" or "Us") warrants to the original purchaser only ("You" or "Your") that the Powerhorse product purchased will be free from material defects in both materials and workmanship, normal wear and tear excepted, for a period of **two years** from date of purchase. The foregoing warranty is valid only if the installation and use of the product is strictly in accordance with product instructions. There are no other warranties, express or implied, including the warranty of merchantability or fitness for a particular purpose. If the product does not comply with this limited warranty, Your sole and exclusive remedy is that We will, at our sole option and within a commercially reasonable time, either replace or repair the product or product component without charge to You or refund the purchase price (less shipping). This limited warranty is not transferable.

Limitations on the Warranty

This limited warranty does not cover: (a) normal wear and tear; (b) damage through abuse, neglect, misuse, or as a result of any accident or in any other manner; (c) damage from misapplication, overloading, or improper installation; (d) improper maintenance and repair; and (e) product alteration in any manner by anyone other than Us, with the sole exception of alterations made pursuant to product instructions and in a workmanlike manner.

Obligations of Purchaser

You must retain Your product purchase receipt to verify date of purchase and that You are the original purchaser. To make a warranty claim, contact Us at 1-866-443-2576, identify the product by make and model number, and follow the claim instructions that will be provided. The product and the purchase receipt must be provided to Us in order to process Your warranty claim. Any returned product that is replaced or refunded by Us becomes our property. You will be responsible for return shipping costs or costs related to Your return visit to a retail store.

Remedy Limits

Product replacement, repair or a refund of the purchase price is Your sole remedy under this limited warranty or any other warranty related to the product. We shall not be liable for: service or labor charges or damage to Your property incurred in removing or replacing the product; any damages, including, without limitation, damages to tangible personal property or personal injury, related to Your improper use, installation, or maintenance of the product or product component; or any indirect, incidental or consequential damages of any kind for any reason.

Assumption of Risk

You acknowledge and agree that any use of the product for any purpose other than the specified use(s) stated in the product instructions is at Your own risk.

Governing Law

This limited warranty gives You specific legal rights, and You also may have other rights which vary from state to state. Some states do not allow limitations or exclusions on implied warranties or incidental or consequential damages, so the above limitations may not apply to You. This limited warranty is governed by the laws of the State of Minnesota, without regard to rules pertaining to conflicts of law. The state courts located in Dakota County, Minnesota shall have exclusive jurisdiction for any disputes relating to this warranty.

U.S EPA AND CALIFORNIA EMISSION CONTROL

WARRANTY STATEMENT

YOUR WARRANTY RIGHTS AND OBLIGATIONS

The California Air Resources Board, The United States Environmental Protection Agency (US EPA) and Northern Tool & Equipment Company, Inc. are pleased to explain the emission control system warranty on your 2016 and later model year small off-road engine. In the United States and California new small off-road engines must be designed built and equipped to meet the State's stringent anti-smog standards. Northern Tool & Equipment Company, Inc. must warrant the emissions control system on your small off-road engine for the periods of time listed below provided there has been no abuse, neglect or improper maintenance of your small off-road engine.

Your emission control system may include parts such as the carburetor, fuel tanks, cans and lines, fuel injection system, the ignition system and catalytic converter. Also included may be hoses, belts, connectors and other emission related assemblies.

Where a warrantable condition exists, Northern Tool & Equipment Company, Inc. will repair your small off-road engine at no cost to you including diagnosis, parts and labor.

MANUFACTURER'S WARRANTY COVERAGE

The emissions control system is warranted for two years. If any emissions-related part on your engine is defective, the part will be repaired or replaced by Northern Tool & Equipment Company, Inc.

OWNER'S WARRANTY RESPONSIBILITIES

As the small off-road engine owner, you are responsible for the performance of the required maintenance listed in your owner's manual. Northern Tool & Equipment Company, Inc. recommends that you retain all receipts covering maintenance on your small off-road engine, but Northern Tool & Equipment Company, Inc. cannot deny warranty solely for the lack of receipts or for your failure to ensure the performance of all scheduled maintenance.

As the small off-road engine owner, you should however be aware that Northern Tool & Equipment Company, Inc. may deny you warranty coverage if your small off-road engine or a part has failed due to abuse, neglect, improper maintenance or unapproved modifications.

You are responsible for presenting your small off-road engine to a Northern Tool & Equipment Company, Inc. distribution center or service center as soon as a problem exists. The warranty repairs should be completed in a reasonable amount of time, not to exceed 30 days.

If you have any questions regarding your warranty rights and responsibilities, contact Northern Tool & Equipment Company, Inc.:

TEL: 1-866-443-2576 or visit: www.northerntool.com

This telephone number is only for the engines which the company name "Northern Tool & Equipment Company, Inc." on the emission label.

E795771A_2016

DEFECTS WARRANTY COVERAGE

Adopted by the Air Resources Board, Northern Tool & Equipment Company, Inc. warrants to the ultimate purchaser and each subsequent purchaser that the small off-road engine (1) has been designed, built and equipped so as to conform with all applicable regulations; and (2) is free from defects in materials and workmanship that cause the failure of a warranted part to conform with those regulations as may be applicable to the terms and conditions stated below:

(a) The warranty period begins on the date the engine is delivered to an ultimate purchaser or first placed into service. The warranty period is two years.

(b) Subject to certain conditions and exclusions as stated below, the warranty on emissions related parts is as follows:

(1) Any warranted part that is not scheduled for replacement as required maintenance in your Owner's Manual is warranted for the warranty period stated above. If the part fails during the period of warranty coverage, the part will be repaired or replaced by Northern Tool & Equipment Company, Inc. according to Subsection (4) below. Any such part repaired or replaced under warranty will be warranted for the remainder of the period.

(2) Any warranted part that is scheduled only for regular inspection in your Owner's Manual is warranted for the warranty period stated above. Any such part repaired or replaced under warranty will be warranted for the remaining warranty period.

(3) Any warranted part that is scheduled for replacement as required maintenance in your Owner's Manual is warranted for the period of time before the first scheduled replacement date for that part. If the part fails before the first scheduled replacement, the part will be repaired or replaced by Northern Tool & Equipment Company, Inc. according to Subsection (4) below. Any such part repaired or replaced under warranty will be warranted for the remainder of the period prior to the first scheduled replacement point for the part.

(4) Repair or replacement of any warranted part under the warranty provisions herein must be performed at a warranty station at no charge to the owner.

(5) Notwithstanding the provisions herein, warranty services or repair will be provided at all of our distribution centers that are franchised to service the subject engines.

(6) The engine owner must not be charged for diagnostic labor that leads to the determination that a warranted part is in fact defective, provided that such diagnostic work is performed at a warranty station.

(7) Northern Tool & Equipment Company, Inc. is liable for damages to other engine components proximately caused by a failure under warranty of any warranted part.

(8) Throughout the engine warranty period stated above, Northern Tool & Equipment Company, Inc. will maintain a supply of warranted parts sufficient to meet the expected demand for such parts.

(9) Any replacement part may be used in the performance of any warranty maintenance or repairs and must be provided without charge to the owner. Such use will not reduce the warranty obligations of Northern Tool & Equipment Company, Inc.

(10) Add-on or modified parts that are not exempted by the Air Resources Board may not be used. The use of any non-exempted add-on or modified parts by the ultimate purchaser will be grounds for disallowing a warranty claims. Northern Tool & Equipment Company, Inc. will not be liable

E795771A_2016

to warrant failures of warranted parts caused by the use of a non-exempted add-on or modified part.

(11) The manufacturer issuing the warranty shall provide any documents that describe that manufacturer's warranty procedures or policies within five working days of request by the Air Resources Board.

ENGINE INFORMATION

Brand: Powerhorse

Engine Family: GCDPS.2121DJ, GCDPS.4572DJ

EMISSION WARRANTY PARTS LIST

The repair or replacement of any warranted part otherwise eligible for warranty coverage may be excluded from such warranty coverage if Northern Tool & Equipment Company, Inc. demonstrates that the engine has been abused, neglected, or improperly maintained, and that such abuse, neglect, or improper maintenance was the direct cause of the need for repair or replacement of the part. That notwithstanding, any adjustment of a component that has a factory installed, and properly operating, adjustment limiting device is still eligible for warranty coverage. The following emissions warranty parts for each engine family list is covered.

(a) Fuel Metering System:

- (1) Carburetor and internal parts (and/or pressure regulator or fuel injection system).
- (2) Air/fuel ratio feedback and control system.
- (3) Cold start enrichment system.

(4) Fuel tank.

(b) Air induction system:

- (1) Controlled hot air intake system.
- (2) Intake manifolds.
- (3) Air filter.

(c) Ignition System:

- (1) Spark Plugs.
- (2) Magneto or electronic ignition system.
- (3) Spark advance/retard system.

(d) Exhaust Gas Recirculation (EGR) System:

- (1) EGR valve body, and carburetor spacer if applicable.
- (2) EGR rate feedback and control system.

E795771A_2016

(e) Air Injection System:

- (1) Air pump or pulse valve.
- (2) Valves affecting distribution of flow.
- (3) Distribution manifold.

(f) Catalyst or Thermal Reactor System:

(1) Catalytic converter.

(2) Thermal reactor.

(3) Exhaust manifold.

(g) Particulate Controls:

(1) Traps, filters, precipitators, and any other device used to capture particulate emissions.

(h) Miscellaneous Items Used in Above Systems:

(1) Electronic controls.

(2) Vacuum, temperature, and time sensitive valves and switches.

(3) Hoses, belts, connectors, and assemblies.

Northern Tool & Equipment Company, Inc. will furnish with each new engine written instructions for the maintenance and use of the engine by the owner.

E795771A_2016



Distributed by:

Northern Tool & Equipment Company, Inc.

Burnsville, Minnesota 55306

www.northerntool.com

Made in China