

**READ THIS MANUAL BEFORE USING THIS PRODUCT. FAILURE TO FOLLOW THE INSTRUCTIONS AND SAFETY PRECAUTIONS IN THE MANUAL CAN RESULT IN SERIOUS INJURY OR DEATH. KEEP THIS MANUAL FOR FUTURE REFERENCE.**



The Submersible Utility Pump is designed for non-automatic use in water. The unit is equipped with a 10 foot, 3-prong grounding type power cord. The motor is oil-filled and sealed for cooler operation. Both discharge fittings are designed for convenient attachment to a garden hose.

### Safety Signal Words

**⚠ DANGER** indicates an imminently hazardous situation which, if NOT avoided, WILL result in death or serious injury.

**⚠ WARNING** indicates a potentially hazardous situation which, if NOT avoided, COULD result in death or serious injury.

**⚠ CAUTION** indicates a potentially hazardous situation which, if NOT avoided, MAY result in minor or moderate injury.

**NOTICE** indicates important information, that if NOT followed, MAY cause damage to equipment.

This is a safety alert symbol. It is used to alert you to potential personal injury hazards. The meaning of this safety alert symbol is as follows: **Attention! Become alert! Your Safety may be at risk.** The message that appears next to the warning which can be either written or pictorially presented. NEVER remove or tamper with the warning labels or safety devices of the pump.



Most electric product-related incidents are caused by failure to observe basic safety rules or precautions. WAYNE Water Systems is NOT responsible for any bodily injury or property damage that may result from operation outside of the normal operating conditions.

**⚠ DANGER** If using pump to drain a vessel of water make sure the pump is not used while people are in, or in-contact with the water.

### ⚠ DANGER

- DO NOT pump flammable or explosive fluids such as gasoline, fuel oil, kerosene, solvents, thinners, etc. DO NOT use in a flammable and/or explosive atmosphere. ONLY pump clear water. Improper use could result in death or serious injury.
- Keep children and others away. Children must NEVER be allowed in the work area.



### ⚠ DANGER

- Electric shock hazard! GFCI receptacles will provide protection against line to ground faults only. The ground fault receptacle does NOT limit the magnitude of fault current and will NOT prevent an electrical shock. Replace damaged cord immediately.

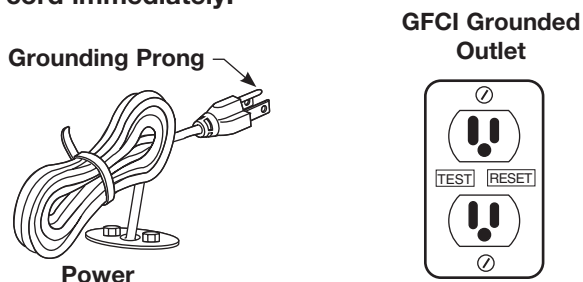

Figure 1

- This pump must be plugged into a properly installed, and grounded GFCI outlet in accordance with all applicable codes and ordinances. (Figure 1) Never remove the grounding prong or modify the plug in any way. Do not use any adapter plugs. Check with a qualified electrician if you are not sure the outlet is grounded. If the pump should electrically malfunction or break down, grounding provides a low resistance path to carry electricity away from the user.
- Before each use inspect pump, power cord and plug for damage. If damage is present DO NOT USE pump.
- Electrical wiring must be performed by a qualified electrician. Improper wiring could result in fatal electrical shock.
- Do not abuse cord. Never use the cord to carry the pump or pull the plug from an outlet. Keep cord away from heat, oil, sharp edges, or moving parts. Replace damaged cords immediately. Damaged cords increase the risk of electrical shock.
- Do not use an extension cord. This increases the risk of electrical shock. If necessary, install a properly grounded GFCI outlet closer to the pump.

**▲ WARNING**

- Stay alert, watch what you are doing, and use common sense when using this pump. Do not attempt to use this pump while tired or under the influence of drugs, alcohol or medications. A moment of inattention may result in serious personal injury.
- Dress properly. Do not wear loose clothing or jewelry. Contain long hair. Keep your hair, clothing, and gloves away from moving parts. Loose clothes, jewelry, or long hair can be caught in moving parts.
- Do not overreach. Keep proper footing and balance at all times. Proper footing and balance enables better control in unexpected situations.
- Use safety equipment. Always wear eye protection. Dust mask, non-skid safety shoes and hard hat must be used for appropriate conditions.

**▲ WARNING**

If using pump to drain a vessel containing heated water, allow water time to cool to ambient temperature before pumping the water. Failure to do so may cause pump failure or property damage.

**Service**

**▲ WARNING**

- This product is not approved for permanent pool applications or as a pool or spa-cover drain pump.
- Pump service must be performed only by qualified repair personnel. Service or maintenance performed by unqualified repair personnel could result in injury and may void the warranty.
- When servicing a pump, use only identical replacement parts. Follow instructions in the Maintenance Section of this manual. Use of unauthorized parts or failure to follow maintenance instructions may create a risk of electrical shock or injury and may void the warranty.



**Specific Safety Information**

**▲ WARNING**

Risk of electric shock. This pump is supplied with a grounding-type plug. To reduce risk of electric shock be certain that it is connected only to a properly grounded, GFCI receptacle.



For your own safety, before operating this unit, read this operators manual carefully and completely. Learn the operation, application, and potential hazards peculiar to this unit.

Call the WAYNE Pumps, Technical Service Department at 800.237.0987 if you have any questions.

**Utility Pump Safety**

**▲ DANGER**

- DO NOT pump flammable or explosive liquids such as gasoline, fuel oil, kerosene, solvents, thinners, etc. DO NOT use in a flammable and/or explosive atmosphere. ONLY pump clear water. Improper use could result in death or serious injury.
- If there is water or moisture on the floor, do not walk on wet area until all power is turned off. If the shut-off box is in the basement, call an electrician. Failure to follow this warning could result in fatal electrical shock.
- Disconnect power before servicing. Improper use could result in death or serious injury.
- DO NOT handle a pump or pump motor with wet hands or when standing on wet or damp surface or in water when pump is connected to power source.



**Specifications**

**NOTICE**

- This pump is not designed to handle salt water, brine, laundry discharge, or any other application which may contain caustic chemicals, highly chlorinated water, and/or foreign materials. This pump is not suitable for use with aquatic life. Pump damage or failure could occur if used in these applications and will void the warranty.

**Pump Application**

**⚠ DANGER**

- Pump should only be used to pump clear water. Do not use to pump fluids such as gasoline, fuel oil, or kerosene. Do not use in a flammable or explosive atmosphere. Improper use could result in personal injury and/or death.

**⚠ WARNING**

- Disconnect power before servicing. Improper use could result in death or serious injury.
- DO NOT handle a pump or pump motor with wet hands or when standing on wet or damp surface or in water when pump is connected to power source.



1. This pump has been designed to attach to a standard garden hose. Thread the female end of the garden hose to either discharge on the pump. Make sure the discharge not being used is securely sealed using the attached screw-on cap. (if unused discharge is not capped, water will not be pumped through the garden hose).
2. To reduce leakage between the pump and the hose, place a hose washer (not included) on the garden hose before attaching to the pump.
3. For best pump performance, unwind the hose before starting the pump. This will help remove any kinks or binds in the hose and allow the unit to pump with less restriction.
4. Place pump on a hard surface in the water. Do not set the pump directly on mud or sand surfaces. This will cause the inlet screen to clog. For best results clean an area on the hard surface for the pump to sit while working. The filter features of this pump work best if the debris is filtered from the outside in. Sitting the pump directly on a loose/dirty surface will not allow the filter features to work to their full extent.

A flat object such as a piece of hardwood or rigid plastic (e.g. 5 gallon bucket lid) can be placed under the pump if no clean hard surface can be found. However, this will increase the priming and pump down levels.

**NOTICE**

Do not place pump directly on clay, gravel, leaves or any loose or sandy surfaces. These surfaces contain small stones, sand, or debris that may clog or damage the pump. This could result in pump failure causing flooding and property damage.

for the pump to operate. Water levels less than 3/16 inch will not allow the impeller to contact water and no water will be pumped.

6. Inspect the pump housing, power cord, and plug for damage or leaks. If the plug is missing the grounding prong or the cord is damaged, do not use the pump until the cord has been replaced. If the pump housing is damaged or leaking discard of pump, DO NOT USE.

**⚠ WARNING**

Never cut off grounding prong or use an adapter.

7. Always know where your discharge hose is placed. An unsecured discharge hose may move or whip when the pump is turned on.
8. Plug the power cord into a grounded 120 VAC GFCI protected power outlet. Make sure the electrical outlet is grounded and is rated for at least 15 amps. The pump will start operating as soon as the power cord is plugged into the power outlet.
9. The pump will remove water down to approximately 1/16 inch of the surface the pump was placed on. Removing water down to 1/16 inch is based on many factors. For pump to remove water as low as possible the pump must be on a level surface.
10. The pump should be unplugged once the water is no longer being moved, or pump will run dry.

**NOTICE**

Do not allow pump to run dry. The shaft seal depends on water for lubrication. Operating the pump without water will damage the shaft seal and cause pump failure.

**NOTICE**

When the water level is approaching the minimum pumping limit (1/16 inch), the water removal rate may slow, and the pump may become more noisy. This is due to air being drawn into the pump in addition to water. During this time the pump may still remove water. Once water has stopped coming out of the hose unplug pump to avoid running dry.

**⚠ WARNING**

When routing the electrical cord protect cord from sharp objects, hot surfaces, oils, and chemicals. Do not kink cord; replace any damaged cord immediately.

**Maintenance Instructions**

5. The water level must be at least 3/16 inch deep

**⚠ WARNING** Disconnect power before servicing. Improper use could result in death or serious injury.

1. Keep pump inlet clean and free of all foreign objects. Inspect inlet at beginning of each use.
2. The motor housing is completely sealed and requires no service. Disassembly of the motor housing or alteration of the power cord could result in fatal electrical shock.



### SERVICE AND REPAIR

**NOTICE** Service work on this pump must be performed by qualified repair personnel. ONLY use identical WAYNE replacement parts.

**⚠ WARNING** When servicing this pump, only identical WAYNE replacement parts should be used. Failure to follow these steps may create a risk of flooding, property damage, fatal electrical shock, or other serious injury.

If you have any questions regarding the service or repair of this machine, call or write to:

WAYNE Pumps  
Attn. Technical Services Department  
101 Production Drive  
Harrison, Ohio 45030  
Tel: 1.800.237.0987

**NOTE:** Debris filter will not protect pump from all debris. If reduced performance is noticed it may be necessary to clean the volute and impeller.

### VOLUTE AND IMPELLER CLEANING

- a. Unplug pump
- b. Remove 6 black screws shown in (Figure 2)
- c. Remove volute and clean impeller and volute of all debris.
- d. Reposition cork gasket using alignment features taking care not to obstruct pump discharge openings.
- e. Reinstall volute using caution not to overtighten or strip screws or screw bosses.

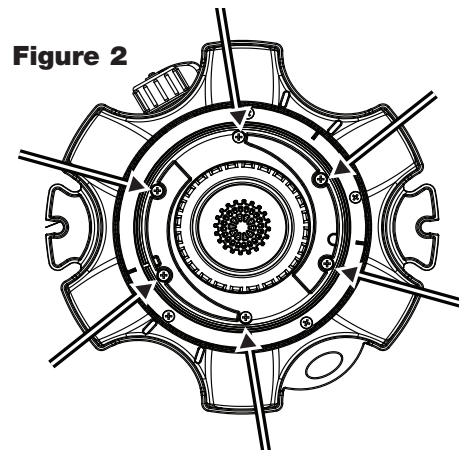

### CALIFORNIA PROPOSITION 65

**⚠ WARNING** This product or its power cord may contain chemicals, including lead, known to the State of California to cause cancer and birth defects or other reproductive harm. Wash hands after handling.

## TROUBLESHOOTING CHART

Symptom	Possible Cause(s)	Corrective Action
Pump will not start or run	<ol style="list-style-type: none"> <li>1. Blown fuse or breaker</li> <li>2. Low line voltage</li> <li>3. Worn motor</li> <li>4. Impeller not rotating (Jammed)</li> <li>5. Thermal Protector open</li> </ol>	<ol style="list-style-type: none"> <li>1. Check pump housing or power cord for damage, before replacing fuse or resetting breaker. If in doubt call an electrician.</li> <li>2. Contact an electrician.</li> <li>3. Replace pump.</li> <li>4. If impeller will not turn, disconnect pump from power source and remove blockage. (see Volute and Impeller cleaning instructions)</li> <li>5               <ol style="list-style-type: none"> <li>a. Water temperature is too high, allow water to cool before pumping.</li> <li>b. Inlet clogged, remove debris.</li> <li>c. Motor seized, replace pump.</li> <li>d. Discharge clogged or hose kinked/clogged. Clear blockage</li> </ol> </li> </ol>
Pump starts but delivers little or no flow	<ol style="list-style-type: none"> <li>1. Inlet clogged</li> <li>2. Low line voltage</li> <li>3. Restriction in discharge hose</li> <li>4. Discharge lift too high</li> <li>5. Impeller Clogged</li> </ol>	<ol style="list-style-type: none"> <li>1. Clean debris from exterior of volute and all debris filtering features.</li> <li>2. Contact an electrician</li> <li>3. Unwind garden hose, remove any kinks or restrictions in hose.</li> <li>4. Water level to end of garden hose is 25 ft. or greater, reduce vertical lift.</li> <li>5. Disconnect pump from power source and remove blockage. (see Volute and Impeller cleaning instructions)</li> </ol>





## LIMITED WARRANTY

For one (1) year on model WWB, from date of purchase, WAYNE Water Systems ("WAYNE") will repair or replace, at its option, for the original purchaser any part or parts of its Sump Pumps or Water Pumps ("Product") found upon examination by WAYNE to be defective in materials or workmanship. Please call WAYNE (800-237-0987) for instructions or see your dealer. Be prepared to provide the model number when exercising this warranty. All transportation charges on Products or parts submitted for repair or replacement must be paid by purchaser.

This Limited Warranty does not cover Products which have been damaged as a result of accident, abuse, misuse, neglect, improper installation, improper maintenance, or failure to operate in accordance with WAYNE's written instructions.

**THERE IS NO OTHER EXPRESS WARRANTY. IMPLIED WARRANTIES, INCLUDING THOSE OF MERCHANTABILITY AND FITNESS FOR A PARTICULAR PURPOSE, FOR ONE (1) YEAR (WWB) FROM DATE OF PURCHASE. THIS IS THE EXCLUSIVE REMEDY AND ANY LIABILITY FOR ANY AND ALL INDIRECT OR CONSEQUENTIAL DAMAGES OR EXPENSES WHATSOEVER IS EXCLUDED.**

Some states do not allow limitations on how long an implied warranty lasts, or do not allow the exclusions or limitations of incidental or consequential damages, so the above limitations might not apply to you. This limited warranty gives you specific legal rights, and you may also have other legal rights which vary from state to state.

In no event, whether as a result of breach of contract warranty, tort (including negligence) or otherwise, shall WAYNE or its suppliers be liable for any special, consequential, incidental or penal damages including, but not limited to loss of profit or revenues, loss of use of the products or any associated equipment, damage to associated equipment, cost of capital, cost of substitute products, facilities, services or replacement power, downtime costs, or claims of buyer's customers for such damages.

You **MUST** retain your purchase receipt along with this form. In the event you need to exercise a warranty claim, you **MUST** send a **copy** of the purchase receipt along with the material or correspondence. Please call WAYNE (800-237-0987) for return authorization and instructions.

**DO NOT MAIL THIS FORM TO WAYNE.** Use this form only to maintain your records.

MODEL NO. \_\_\_\_\_ SERIAL NO. \_\_\_\_\_ INSTALLATION DATE \_\_\_\_\_

**ATTACH YOUR RECEIPT HERE**

## GARANTIE LIMITÉE

Pour uno an sur Modèle WWB, à compter de la date d'achat pour l'acheteur originel, WAYNE Water Systems ("WAYNE") va réparer ou remplacer, à son option, pour l'acheteur originel n'importe quelle pièce ou pièces de ces Pompes De Puisard ou Pompes À Eau ("Produit") déterminées défectueuses, par WAYNE, en matière ou en fabrication. S'il vous plaît appeler WAYNE (800-237-0987) pour des instructions ou contacter votre marchand. S'assurer d'avoir, à votre disposition, le numéro du modèle afin d'effectuer cette garantie. Les frais de transportation des Produits ou pièces soumis pour la réparation ou le remplacement sont la responsabilité de l'acheteur.

Cette Garantie Limitée ne couvre pas les Produits qui se sont fait endommagés en résultat d'un accident, utilisation abusive, mauvais usage, négligence, l'installation incorrecte, entretien incorrect, ou manque d'utilisation conformément aux instructions écrit de WAYNE.

**IL N'EXISTE AUCUNE AUTRE GARANTIE OU AFFIRMATION. LES GARANTIES IMPLICITES, INCLUANT CELLES DE QUALITÉ MARCHANDE ET CONVENABLE À UN USAGE PARTICULIER, OU POUR UN (1) AN (WWB) DE LA DATE D'ACHAT. CECI EST LA REMÈDE EXCLUSIVE ET N'IMPORTE QUELLE RESPONSABILITÉ POUR N'IMPORTE QUEL ET TOUT DOMMAGES INDIRECTS OU DÉPENSES QUOI QUE SE SOIT EST EXCLUS.**

Certaines Provinces n'autorisent pas de limitations de durée pour les garanties implicites, ni l'exclusion ni la limitation des dommages fortuits ou indirects. Les limitations précédentes peuvent donc ne pas s'appliquer. Cette garantie limitée donne, à l'acheteur, des droits légaux précis, et vous pouvez avoir autres droits légaux qui sont variable d'une Province ou d'un État à l'autre.

En aucun cas, soit par suite d'un rupture de contrat de garantie, acte dommageable (y compris la négligence) ou autrement, ni WAYNE ou ses fournisseurs seront responsables pour aucune dommage spéciale, incidentel ou pénal, y compris, mais pas limité à la perte de profits ou recettes, la perte d'usage des produits ou n'importe quel équipement associé, dommage à l'équipement associé, coût de capital, coût de produits remplaçants, aménagements, services ou abilité de remplacement, coût de temps que le produit n'est pas en service, ou la réclamation des clients de l'acheteur pour ces dommages.

Vous **DEVEZ** garder votre recette d'achat avec ce bulletin. Il est **NÉCESSAIRE** d'envoyer une **copie** de la recette d'achat avec le matériel ou correspondance afin d'effectuer une réclamation de la garantie. S'il vous plaît appeler WAYNE (800-237-0987) pour l'autorisation et instructions concernant le renvoi.

**NE PAS ENVOYER, PAR LA POSTE, CE BULLETIN À WAYNE.** Utiliser ce bulletin seulement pour vos archives.

N° DU MODÈLE \_\_\_\_\_ N° DE SÉRIE \_\_\_\_\_ DATE D'INSTALLATION \_\_\_\_\_

**FIXER VOTRE FACTURE ICI**

## GARANTIA LIMITADA

Para uno (1) año para los Modelo WWB, a partir de la fecha de compra al comprador original. Durante estos periodos la compañía Wayne Water Systems (Wayne) le reparará o reemplazará, según se decida, al comprador original cualquier pieza o piezas de las bombas para sumideros o bombas de agua (Producto) que después de haber sido examinadas por Wayne se encuentren dañados debido al material o proceso de fabricación utilizados. Sirvase llamar a WAYNE (800-237-0987) para recibir instrucciones o comuníquese con la tienda donde compró el producto. Deberá suministrar el número del modelo y serie en el momento de presentar un reclamo bajo esta garantía. El comprador será responsable por los gastos de flete de los productos o piezas enviados para ser reparados o reemplazados.

Esta garantía limitada no cubre los daños debido a accidentes, abusos, uso inadecuado, negligencia, instalación inadecuada, mantenimiento inadecuado, o funcionamiento sin seguir las instrucciones suministradas por escrito por la compañía WAYNE.

**NO HAY NINGUNA OTRA GARANTIA EXPRESA O IMPLISITA. LAS GARANTÍAS IMPLÍCITAS, INCLUYENDO AQUELLAS DE COMERCIALIZACIÓN E IDONEIDAD PARA UN PROPÓSITO ESPECÍFICO, O PARA UNO (1) AÑO (WWB) DESDE LA FECHA DE COMPRA. ESTA ES LA UNICA GARANTIA Y CUALQUIER PERDIDA O RESPONSABILIDAD CIVIL, SEA DIRECTA O INDIRECTA COMO CONSECUENCIA DE DAÑOS SON EXCLUIDAS.**

Algunos estados no permiten límites en la duración de las garantías, o no permiten que se limiten o excluyan casos por daños por accidentes o consecuentes, en dichos casos los límites arriba enumerados tal vez no apliquen para Ud. Esta garantía limitada le otorga a Ud. ciertos derechos que pueden variar de un estado a otro.

Bajo ninguna circunstancia, aunque sea debido al incumplimiento del contrato de garantía, culpabilidad (incluyendo negligencia) u otras causas, la compañía WAYNE o ninguno de sus surtidores serán responsables legalmente por ningún fallo legal en su contra, incluyendo, pero no limitado a pérdida de ganancias, pérdidas del uso del producto o piezas asociadas con el equipo, pérdidas de capital, gastos para reemplazar los productos dañados, pérdidas por cierre de fábrica, servicios o pérdida de electricidad, o demandas presentadas por los clientes del comprador por dichos daños.

Ud. **DEBE** conservar el recibo como prueba de compra junto con esta garantía. En caso de que necesite presentar un reclamo de sus derechos bajo esta garantía, Ud. **DEBERA** enviar una **copía** del recibo de la tienda junto con el producto o correspondencia. Comuníquese con la compañía WAYNE (800-237-0987, sólo desde EE.UU) para recibir autorización e instrucciones de como enviar la mercancía.

**NO ENVIE ESTOS DATOS A WAYNE.** Conserve esto sólo como datos.

MODEL NO. \_\_\_\_\_ NO. DE SERIE \_\_\_\_\_ FECHA DE INSTALACION \_\_\_\_\_

**GRAPE SU RECIBO DE COMPRA AQUI**