

Instruction Manual EN

QGS Rotary Compressors

UNITS

Hp 20-25-30

Kw 15-18.5-22

9828 0730 03 ed 00

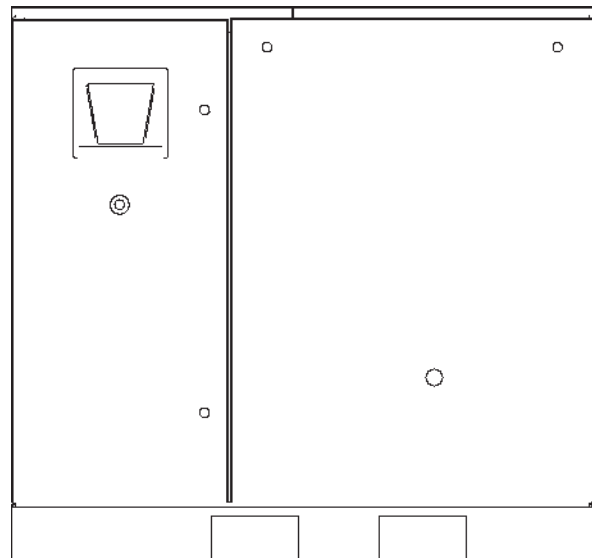

Before carrying out any maintenance, ensure that the compressor has been locked out and tagged out from all power sources

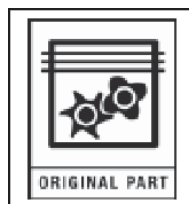

The compressor should never be operated beyond its capabilities or in any way which does not comply with the instructions contained in this operating and maintenance guide.

The manufacturer will decline any responsibility if these instructions are not respected.

This equipment has been factory tested and satisfies normal operating conditions: they must not be exceeded as this would place the machine under abnormal stress and effort.

INSTALLATION INSTRUCTIONS

For the guarantee to be valid, the unit must be assembled in covered premises with temperatures not exceeding :

Mini: + 39,2 °F (frost free)

Maxi: + 104 °F*

You must also have:

3,3 feet space around the compressor

Low ventilation (fresh air) proportionate to the ventilation flow necessary for the machine and protected from any infiltration of humidity (splashes of water during bad weather) and all pollution

Top insulation or extraction to ensure reversal of the flow of warm air and evacuation of the heat to outside the equipment room

A link from the condensation water evacuation pipe to the drain discharger

In dusty environment, pre-filtering the room's air intake and a special filter on the machine's ventilation inlets

TECHNICAL CHARACTERISTICS STANDARD MACHINES

QGS 60 Hz		20			25			30		
Nominal pressure at full capacity	PSI	100	125	150	100	125	150	100	125	150
FAD	cfm	90	84	74	111	99	94	130	122	109
Motor power	kW/hp	15/20			18.5/25			22/30		
Ø Pressure outlet (F)	inch	1"			1"			1"		
Fluid receiver capacity	gal	3			3			3		
Residual quantity of fluid	ppm	3			3			3		
Noise level at 1m	dB (A)	63			66			68		
Dimensions (inch) without dryer	L x l x h	53 x 30 x 48								
Dimensions (inch) with dryer	L x l x h	73 x 30 x 48								
Weight without dryer	lb	893			913			948		
Weight with dryer	lb	1021			1041			1076		

QGS 60 Hz	20	25	30
Motor power kW/hp	15/20	18.5/25	22/30
Voltage 208 / 3 / 60			
Nominal current (A)	58	70	88
Power supply cable AWG	4x4	4x4	4x2
Section mm ² (L= 7m = 23ft maximum)	4x25	4x25	4x2
Upstream fuses (Type J or RK)	80	80	110
Voltage 230 / 3 / 60			
Nominal current (A)	52	62	80
Power supply cable AWG	4x4	4x4	4x2
Section mm ² (L= 7m = 23ft maximum)	4x25	4x25	4x35
Upstream fuses (Type J or RK)	80	80	110
Voltage 460 / 3 / 60			
Nominal current (A)	26	31	40
Power supply cable AWG	4x8	4x8	4x6
Section mm ² (L= 7m = 23ft maximum)	4x10	4x10	4x16
Upstream fuses (Type J or RK)	40	50	60
Voltage 575 / 3 / 60			
Nominal current (A)	21	26	33
Power supply cable AWG	4x10	4x8	4x8
Section mm ² (L= 7m = 23ft maximum)	4x6	4x10	4x10
Upstream fuses (Type J or RK)	30	40	50

MACHINE WITH DRYER MUST BE CONNECTED TO TWO DIFFERENT POWER SUPPLIES: THREE-PHASE OR SINGLE-PHASE SUPPLY FOR THE COMPRESSOR SINGLE-PHASE SUPPLY FOR THE DRYER

DRYER 60 Hz	A7
Motor power kW/hp	0.5 /0.75
Voltage 230 / 1 / 60	
Nominal current (A)	6.5
Power supply cable AWG	3x14
Section mm ² (L= 7m = 23ft maximum)	3x2.5
Upstream fuses (Type J or RK)	8

IMPORTANT: A COPY OF THE WIRING DIAGRAMS CAN BE FOUND INSIDE THE ELECTRIC BOARD OF THE COMPRESSOR. AND A COPY CAN BE FOUND INSIDE THE ENVELOPE DELIVERED WITH THE MACHINE

MACHINE AND MANUFACTURER IDENTIFICATION DATA

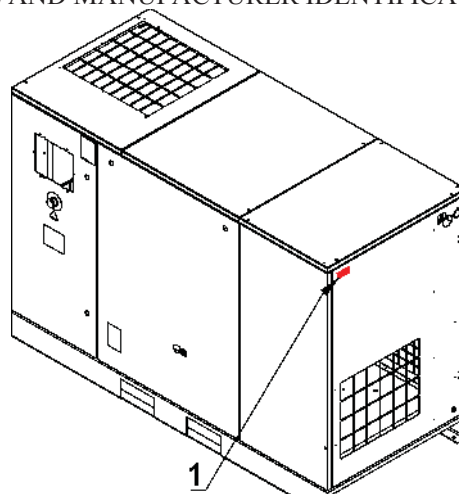

Position of the identification plate Fig. 1

CONTENTS

SECTION I – COMPRESSOR -

Space requirement and installation diagram: compressors 20-25-30	5
--	---

Chapter 1 – Description

A - General	7
B - Respect of the environment and prevention of pollution	7
C - Standard equipment	7
D - Definition of the pictograms	8
E - Position of warning label	8
F - Electronic board	9

Chapter 2 – Installation

A - Handling	10
B - Room	10
C - Assembly	10
D - Air discharge piping	10
E - Electric cabling	10

Chapter 3 - Initial setup

A - Preparation for start-up	11
B - First start-up	11
C - Delivery pressure adjustment	11
D - Adjustment for in parallel operation with other compressors	11
E - Safety	11

Chapter 4 – Operation

A - Air and fluid circuits	12
B - Control principles	13
C - Rotation direction indicator - Phase controller	14

Chapter 5 – Maintenance

A - Introduction	15
B - Air filter	16
C - Turbine	16
D - Fluid and air cooler	16
E - Fluid separator cartridge	16
F - Fluid return pipe	17
G - Draining condensation water	17
H - Temperature safety tests	17
I - Refastening electric connections	17
L - Decommissioning the compressor at the end of its useful life	17
M - Belt tensioning	18
N - Belt removal	19

Chapter 6 - Operating incidents

A - Main incidents	20
--------------------------	----

SECTION II – INFOLOGIC CONTROLLER -

SECTION III – DRYER -

Space requirement and installation diagram: Compressors 20-25-30

(see **chapter 2** - installation instructions)

Fig.1

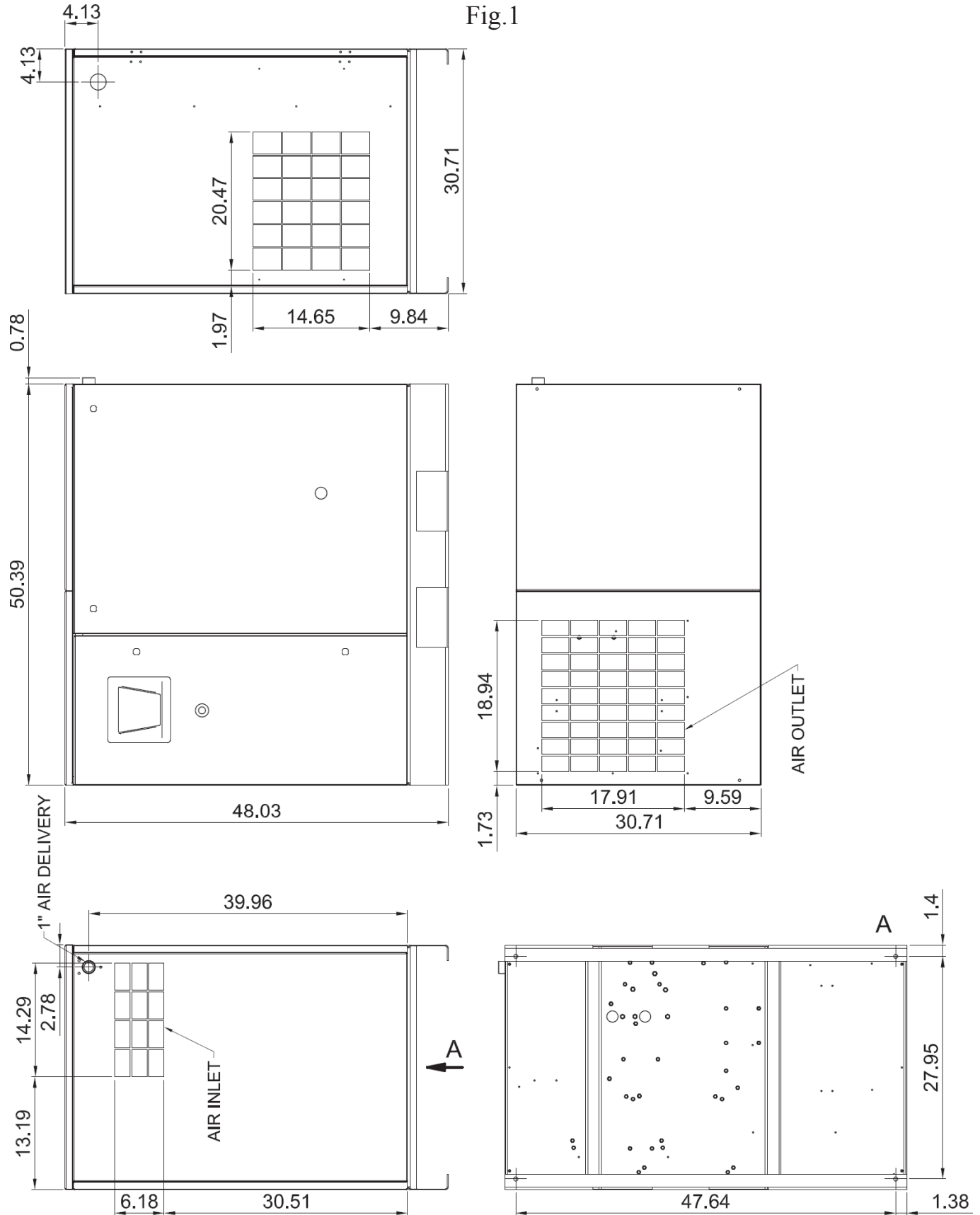

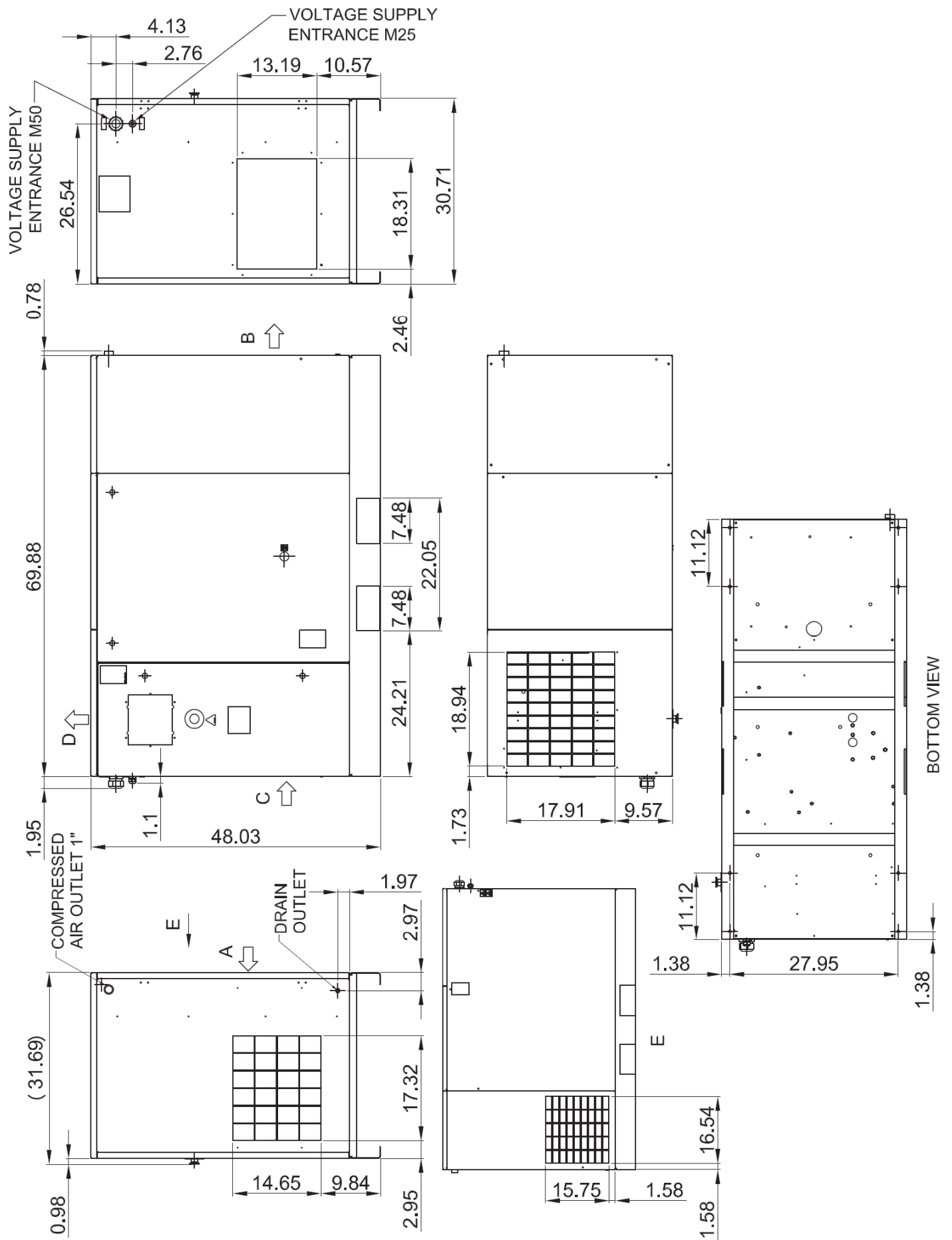

Chapter 1 -Description

A - General

The compressor contains a compressed air unit in the form of a self contained, complete and fully tested assembly, driven by an electric motor and enclosed in an acoustic canopy, necessary for proper cooling of the assembly.

It is an fluid-cooled, single stage, helical screw-type compressor. There is a vertical mounted receiver for pre-separating and storing fluid and air. The air- fluid mixture is then separated by means of a separator cartridge.

Both the compressor and the motor are directly fixed on the frame by anti-vibration pads.

B - Respect of the environment and Prevention of pollution

1 - Maintenance of the machine

Make sure that the used components of the machine (waste fluid, fluid and air filters, fluid separators, etc...) are disposed according to national and local regulations.

2 - Condensate drain pipe

Make sure that the condensates (water, fluid) are drained and treated according to national and local regulations.

3 - End of life of the machine

Make sure that the machine as a whole is disposed according to national and local regulations.

C - Standard equipment

In its standard version, the covered unit

includes: **-Operating components:**

1. A twin-screw compressor lubricated with fluid.
2. An electric motor : 3000 rpm (50Hz) or 3600 rpm (60Hz), short-circuit rotor, voltage 380, 415 V (50Hz) or 208, 230, 460, 575V (60Hz) according to type.
3. Star-delta starting.
4. A V-Belt and pulley system.
5. An air / fluid receiver complying to current regulation.
6. "Start - stop" flow rate control by suction closing.
7. A lubrication system using the differential pressure of the circuit, which avoids the need for an fluid pump.
8. An fluid separation system by means of a separator cartridge.
9. A heat exchanging system : fluid and compressed air cooler with forced ventilation.
10. A dry-type air filter.
11. An fluid filter.
12. A command and control electronic board.
13. INFOLOGIC controller as standard.

- Safety devices:

1. A safety valve mounted on the fluid receiver.
2. An thermal protection device for the motor, located in the starting cubicle, to protect the motor from excessive over-load.
3. A air temperature sensor that stops the compressor when the temperature rises abnormally or during an fluid cooling defect.
4. A pressure sensor that stops the compressor in order to prevent any excessive rise in pressure.

- Control devices:

1. A minimum pressure valve located at the fluid tank outlet, just beyond the fluid separator, which guarantees minimum pressure in the lubrication circuit.
2. Automatic draining allowing the unit to be exposed to the atmosphere when stopping to thus ensure empty start up which relieves the motor,
3. An fluid level gauge on the front panel (see **Fig. 10**),
4. An electronic controller including:
 - a control keyboard,
 - the main safety and control indications.
5. The compressed air output is regulated by a pressure sensor .

D - Definition of the pictograms

Typical examples of pictograms valid for the compressor:

1. Water outlet
2. Manual condensation water draining
3. Water inlet
4. Automatic condensation water draining
5. Unplug and unload the compressor before maintenance

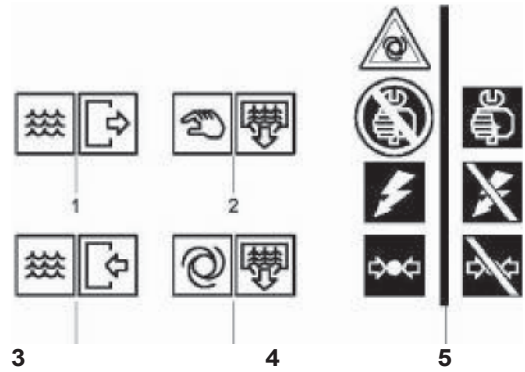

	1) FLUID EJECTION		6) HIGH PRESSURE
	2) DANGEROUS ELECTRIC VOLTAGE		7) HOT PARTS
	3) AIR NOT FIT FOR BREATHING		8) MOVING PARTS
	4) NOISE		9) FAN ROTATING
	5) MACHINE WITH AUTOMATIC START		

E – Position of the warning labels

The plates fitted on the compressor unit are part of the machine; they have been applied for safety purposes and must not be removed or spoiled for any reason.

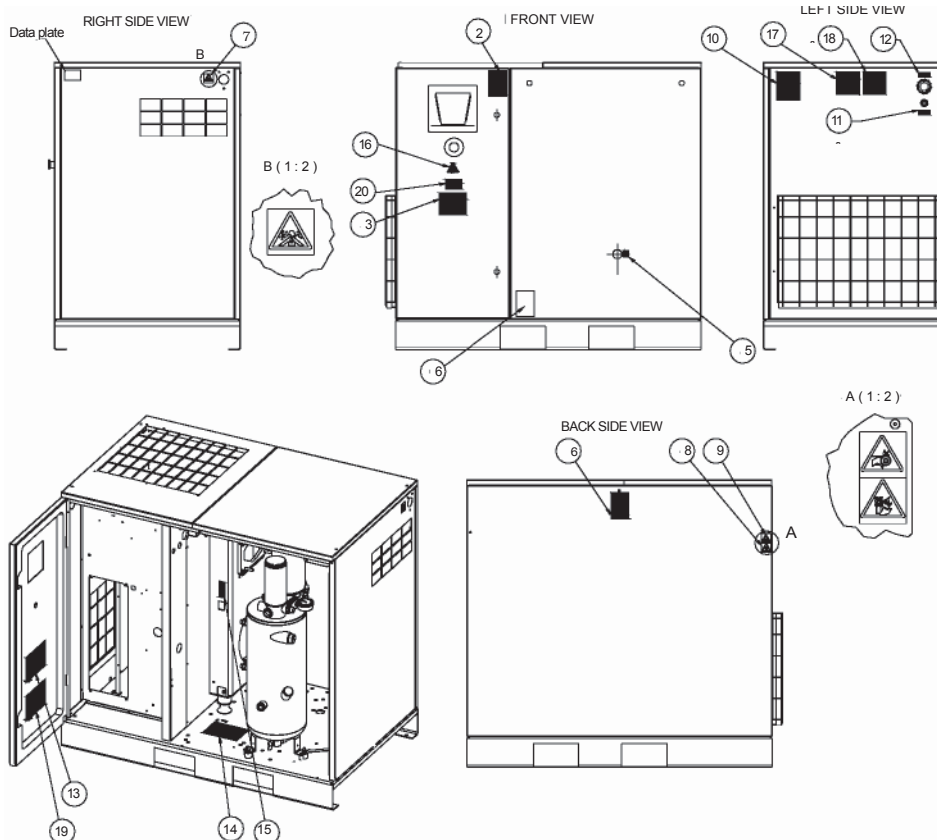

Parts List			
Pos	Qty	Partnumber	Comments
2	1	1079 9903 48	On Cubicle Door
3	1	2202260791	On Cubicle Door
5	1	2202251293	FLUID LEVEL
6	2	2202260791	On Front & Back Door
7	1	2202260791	At Air Outlet
8	1	2202260791	See picture
9	1	2202260791	See picture
10	1		Service Label
		2202965800	20-25 Hp
		2202965900	30 Hp
11	1	2202261000	* ONLY FOR DRYER VERSION
12	1	See BOM	Label voltage
13	1	1079990609	Inside Cubicle Door
14	1	6220561900	On base frame
15	1	2202260791	Direction Arrow
16	1	1088100102	
17			
	1	2202967301	QGS-20 TRIV
	1	2202967302	QGS-25 TRIV
	1	2202967303	QGS-30 TRIV
	1	2202967307	QGS-20 575V
	1	2202967308	QGS-25 575V
	1	2202967309	QGS-30 575V
18	1	2202967306	* ONLY FOR DRYER VERSION
19			
	1	2202967304	Fuses TRI-V UL
	1	2202967310	Fuses 575V UL
20	1	2202261192	

F- Electronic board

The unit is equipped with an **INFOLOGIC**² electronic controller.

See, the specific instructions (SECTION II) for a description of the electronic controller together with operating instructions at the end of this manual.

Chapter 2 -Installation

A - Handling

The compressor must always be handled with care. It may be lifted either with a forklift truck or by means of a travelling crane. In the latter case, precautions must be taken so as not to damage the unit's canopy.

B - Room

The compressor is designed to operate in a frost-free environment, supplied with air at a temperature lower than 104° F. The premises must be well-ventilated and as close as possible to the place where the compressed air is used. A space must be left around the unit for cleaning and maintenance purposes in accordance with NEC or local regulations, whichever has precedence. It is very important for the compressor to have an abundant supply of fresh air.

If operating the compressor causes the ambient temperature to rise above 104 °F, the warm air leaving the cooler must be discharge outside.

COMMENT

When the atmosphere is contaminated by organic or mineral dust or by corrosive chemical emanations the following precautions must be taken:

1. Provide another air intake as close as possible to the suction source of the compressor (this recommendation applies if the only room available is excessively humid).
2. Use an additional filter for the unit's air supply

C - Assembly

Put the unit on a stable surface. The compressor does not need foundations. Any flat surface that can support its weight will be sufficient (industrial floor).

D - Air discharge piping

The diameter of the piping for the air network must at least be equal to 1"/DN30 of the gas piping. Current legislation requires the installation of a valve which can be locked in a closed position at the outlet of the compressor and connected to the compressor by a pipe union or flexible hose so as to isolate it during servicing.

E - Electric cabling

The standard voltage configuration for the compressor is mentioned on the **data plate** of the machine.

NEVER OPERATE THE COMPRESSOR ON A VOLTAGE OTHER DIFFERENT THAN SHOWN ON THE ELECTRIC CABINET.

For tri-voltage machine follow the instructions in the electrical diagram (inside cubicle) to convert the operating voltage of the compressor for either 208V or 230V or 460V

SAFETY REGULATIONS

It should be remembered that safety regulations require :

- A ground to be used.
- A manual isolating switch, cutting all three phases. This switch must be clearly visible near the compressors unit.
- The electric current must be cut whenever maintenance work is carried out on the machine.

Chapter 3 -Initial setup

A - Preparation for start-up

Before starting up the unit for the first time, the operator must be familiar with the different parts of the machine. The main parts which should be examined are indicated in the diagrams.

IMPORTANT

Before start up, make sure that transport red pads have been effectively removed.

WARNING

Please make sure the electrical mains are disconnected before any maintenance or adjustment on the unit in order to avoid any automatic restart.

Before start-up, check the following points :

- 1 -Make sure that the unit is properly grounded.
- 2 -Check the fluid level in the tank. **NOTE** : the tank has been filled with suitable fluid in the factory.
- 3 -Make sure the fluid change valve is properly closed.
- 4 -Check/re-tighten all power connections.

ATTENTION

The fluid filler cap, the fluid change valve and plugs must always remain closed during operation and never be opened before the system has been completely blown off to atmospheric pressure.

B - First start-up

Check the voltage between the three phases before using the unit for the first time. Check the direction of rotation (following the arrow on the pulley-belt support (**item. 1 - Fig. 3**)) by pressing the "Start" button, followed immediately by the emergency stop. If it does not spin in the right direction reverse two mains cables. When it rotates in the correct direction, the fluid level (**Fig.10**) should drop after 4 or 5 seconds of operation.

Fig. 3



- 1 - Press the ON button, the motor starts up.
- 2 - Leave it running for a few minutes with the discharge valve slightly open to observe the compressor under load. Ensure that there are no leaks. Reblock the connectors if necessary.
3. Press the STOP button. The motor stops and the unit is automatically blown off at atmospheric pressure.

C - Delivery pressure adjustment

The unit is adjusted in the factory for a MAXIMUM pressure (for the maximum output from the outlet of the central unit) of 107, 132 or 157 psi depending on the model. To adjust the load pressure setting to a lower value, refer to the manual of the electronic controller.

D - Adjustment for in parallel operation with other compressor

If the compressor has to operate in parallel with other equal, or similar compressors, the discharge pipes can be connected together.

If the compressor has to operate in parallel with one or several alternative compressors, an air tank common to the reciprocating compressors is essential. The impulses emitted by the reciprocating compressors would seriously damage the non-return valve, the separator element and disturb system control. When the rotary compressor operates in parallel with an alternative compressor, the adjustments on the latter will have to be adjusted so that the rotary compressor carries the basic load. This will result in more economic operation.

E - Safety

The fluid used for cooling the machine is an inflammable liquid under the effect of strong heat. In case of fire in the machine, it is essential to respect the regulatory measures on the compressor. The type of fire in a compressor is defined as "class B" and in presence of a live electrical conductor, it is recommended to use a CO₂ extinguisher functioning by "smothering" (starvation of oxygen) while observing the user instructions applicable to the model.

Chapter 4 -Operation

A - Air and fluid circuits

1 - Air circuit (see Fig. 4)

The air is sucked into the compressor through a filter (item. 23). This air passes through the compression element where it is mixed with fluid injected during compression. Inside the tank, the compressed air is separated by shocks and then flows through the fluid separator (item. 49). It then passes through the Minimum pressure valve (item. 34) including a check valve, the final cooler (item. 51A), condensate separator and finally the outlet valve (not supplied) to which the distribution pipes are connected.

2 - Fluid circuit (see Fig. 4)

The fluid, under discharge pressure, flows from the bottom of the tank through the cooler (item. 51H), the fluid filter (item. 26) which retains solid particles, and then into the compressor (item. 20). At each cold start, the thermostatic valve (item. 47) short circuits the fluid cooler, thus enabling the optimum operating temperature to be reached quickly. When it leaves the compressor element, the fluid returns to the tank. Part of the fluid remains suspended in the air as mist. This mist passes through the fluid separator. (item. 49). A fraction of this fluid agglomerates in large droplets which return to the tank through the force of gravity. The remaining fluid, which is separated by the last stage of the fluid separator, is drawn up by a dip tube and dispatched to the compressor.

Key Fig. 4	
20.	Compressor
21.	Inlet valve
23.	Air filter
26.	Fluid filter
28/29/30.	Flexible fluid hose
31/32.	Flexible air hose
34.	Built in minimum pressure valve / Filter support
43.	Drain valve
47.	Thermostatic valve (built in filter support)
49.	Fluid separator
51 A	Air cooler
51 H	Fluid cooler
56.	Motor
57.	Fluid tank

Fig. 4 - Air / fluid circuit

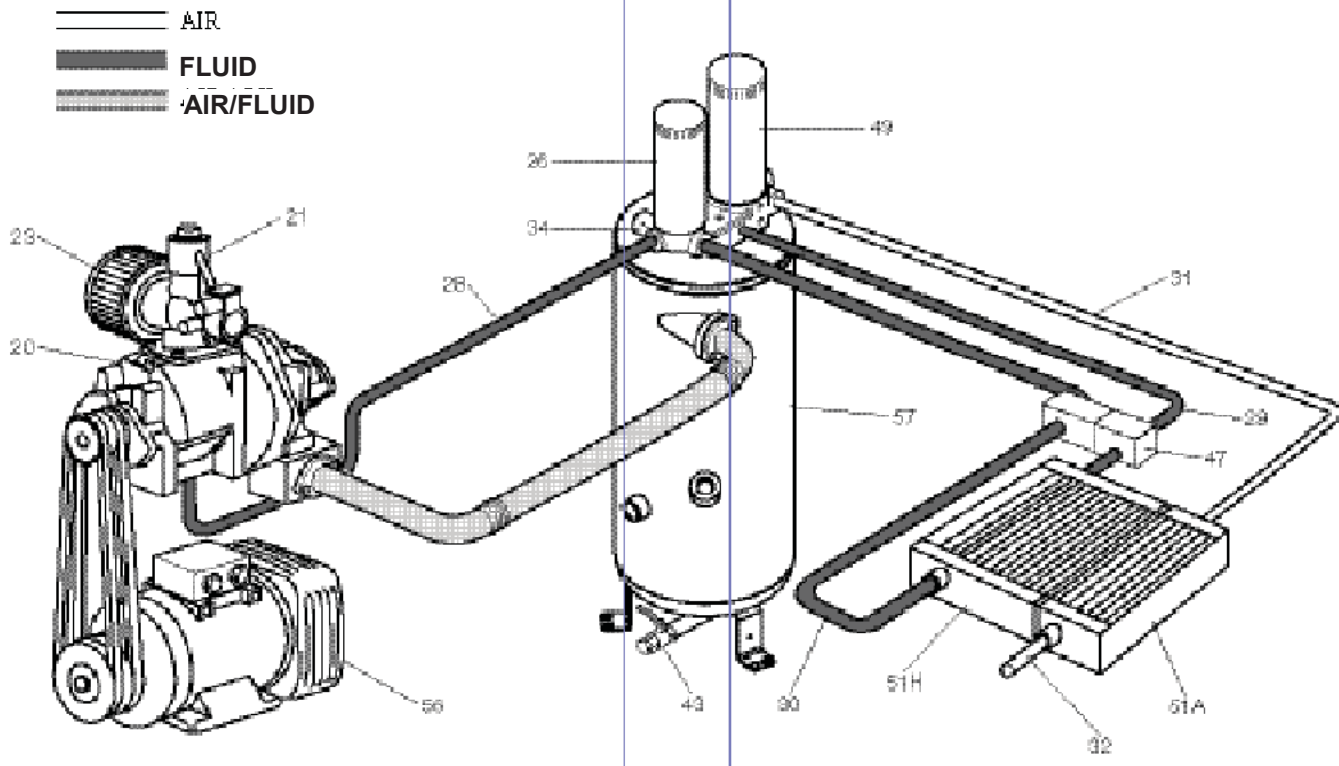

B - Control principles

1 - On/Off Control (see Fig. 5)

Models, all versions

The compressor 20-25-30 units are fitted with an automatic control system, enabling the machine to be stopped after it has run unloaded for a given (adjustable) period of time. This unloaded period is necessary to avoid excessively close start-ups in periods of unstable compressed air consumption.

When the compressor reaches the maximum pressure (measured by the pressure sensor -**item. 36**), the solenoid valve (**item. 35**) releases to the atmosphere the compressed air. The internal pressure closes on one hand the suction box and on the other hand the blow off piston. This results in the release of the internal pressure of the receiver via the by pass check valve."

The compressor draws in air via a by-pass valve (**item. 25**).

The low pressure obtained in the fluid tank enables the compressor to be lubricated and cooled during the whole unloaded period.

If the compressed air pressure in the user network reaches the minimum cutting-in value before the end of the no load operation time out the solenoid valve (**item. 35**) is actuated causing the suction valve to open and the vent to close. The compressor then operates at full output rate.

When the compressor stops, the solenoid valve (**item. 35**) is no longer powered and closes; the suction housing closes and the oil tank is evacuated. The receiver is thus brought back to atmospheric pressure for the next start-up.

Key Fig. 5	
20.	Compressor
21.	Inlet valve
23.	Air filter
25.	By-pass check valve
26.	Fluid filter cartridge
27.	Safety valve
34.	Built in minimum pressure valve / Filter support
35.	Solenoid valve
36.	Pressure sensor
38.	Pneumatic vacuum piston
41.	Ventilation
47.	Thermostatic valve (built in filter support)
49.	Fluid separator
51 A	Air cooler
51 H	Fluid cooler
57.	Fluid receiver
60.	Temperature sensor
63.	Manometer

Fig. 5 - On/Off Control

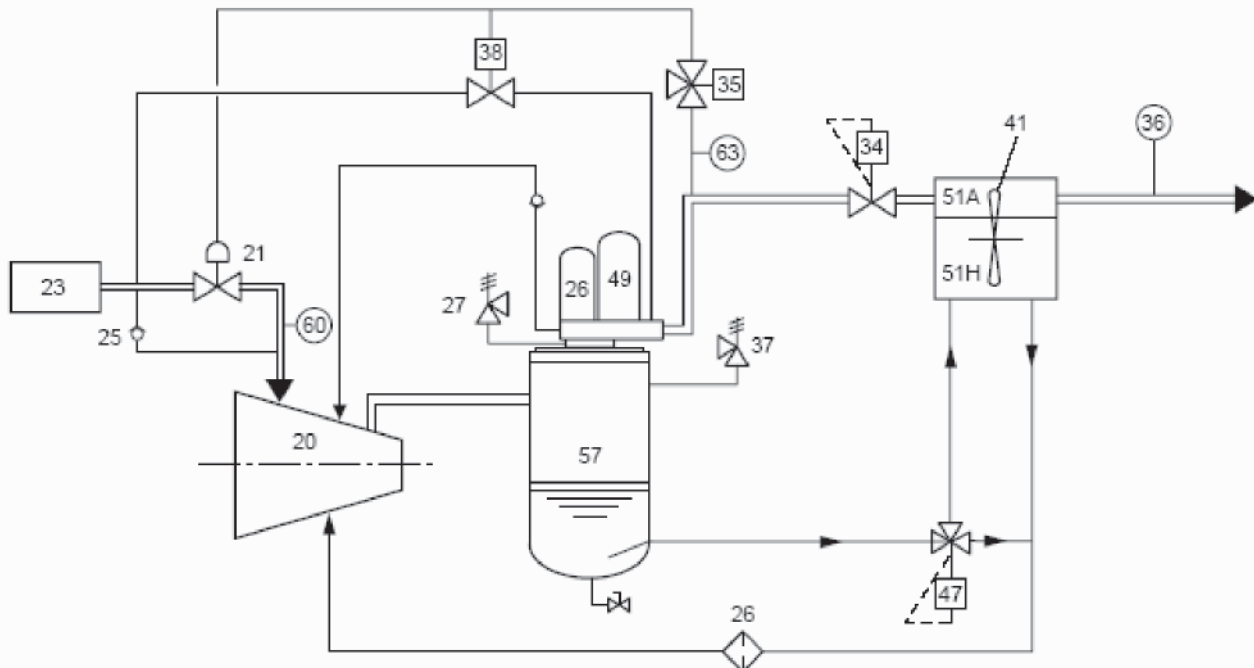

C - Rotation direction indicator Phase controller

1 – Description

The right rotation direction of the main motor of the machine is constantly monitored by the relay CP1 Installed inside electric cabinet (see service diagram).

This option prevents any risk of physical damage by disabling the compressor start up in case of phase reversal or if a phase is disconnected and indicates a machine fault.

CP 1:	Green led ON + Red ON	→	Phase missing
	Green led ON + Red Flashing	→	Reverse phase
	Green led ON + Red OFF	→	OK

Chapter 5 –Maintenance

A – Introduction



Before carrying out any maintenance, ensure that the compressor has been locked out and tagged out from all power sources

The below maintenance table is relating to standard working conditions. Parameters like particular temperature, humidity, dust, chemical environment might significantly impact the component lifetime.

So in such particular conditions, the maintenance table has to be adapted in the field.

The **Original Parts** are designed to ensure, maintain and safeguard the efficiency of the compressor and protect the machine, guaranteeing its long life. Regular replacement of fluid, air and separator filters with **Original Parts** is the only way to ensure better quality air and minimal operating costs.

The first equipment fluid offers maximum performance and protection with its strong resistance to oxidation, top protection from rust and wear, and optimal internal cleaning.

The maintenance period is limited to several essential operations. It is strongly recommended that the power supply be cut off during any adjustment or repair.

The summary on the **Compressor** instrument panel shows at a glance the type and periodicity of operations to be carried out for the compressor to function correctly.

Every Day (after use)	<ul style="list-style-type: none"> ■ Check automatic condensation drain (dryer)
Every 50 working hours	<ul style="list-style-type: none"> ■ Drain condensate from the oil tank ■ Check the oil level ■ Clean the filter of the automatic condensate drain (dryer)
Every 500 hours	<ul style="list-style-type: none"> ■ Replace oil filter (at first 500 hrs) ■ Tighten the screws fixing the electric cables (at first 500 hrs) ■ Clean the air inlet filter ■ Clean the condenser heat exchanger (unit with dryer) ■ Clean the inlet filtration panels (if applicable) ■ Check Belt Tension
Every 2000 hours	<ul style="list-style-type: none"> ■ Replace the inlet air filter ■ ■ Replace the oil filter ■ ■ Retighten all power cable connections ■ ■ Safety temperature test ■ ■ Maintenance kit of the automatic condensate drain (dryer) ■ ■ Oil Fluid sample
Every 4000 hours	<ul style="list-style-type: none"> ■ ■ Clean the finned surface of the air-oil cooler ■ ■ Replace the oil separator filter
Every 8000 hours	<ul style="list-style-type: none"> ■ ■ Check status of oil return valve and oil pipes ■ ■ Replace the oil *

* The compressor must be maintained with QuinSyn-Plus (8,000 hour maximum), QuinSyn-XP (12,000 hour maximum) or QuinSyn-F food grade (6,000 hour maximum). Maximum fluid change intervals are noted per fluid. Actual fluid change interval is to be determined by fluid sampling report, not to exceed maximum fluid change interval. **Fluid samples must be taken every 2,000 hours or as directed by the analysis report.** For light usage units, a fluid sample must be taken a minimum, of every six (6) months, beginning at start-up.

Drain the compressor when warm. In order to do this, stop it and make sure you disconnect the electric supply and close the compressor outlet valve. Loosen the filling plug by one turn to depressurize the receiver in case of component failure. Open the bleeding valve and drain it. Do not forget to close the valve after it has been drained.

After maintenance, a reset has to be done on the counter which indicates the number of remaining hours before the next fluid change see the specific notice on the electronic controller.

FLUID LEVEL (Fig. 10)

When stopped, the MAX level of fluid is 3/4 of the way up from the bottom of the indicator; the MINI level is at the lowest visible part of the indicator.

Fig. 10 - Fluid level

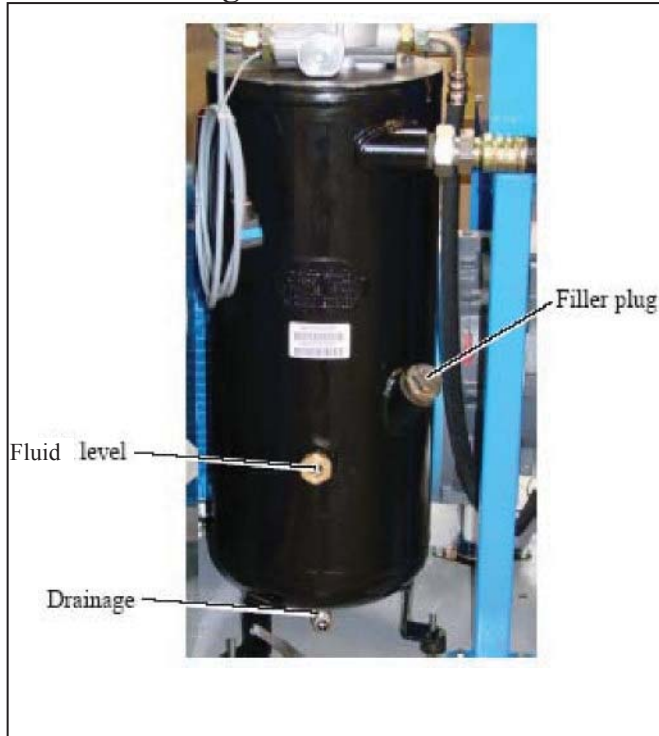

THE FLUID LEVEL HAS TO BE CHECKED AFTER STOP AND WHILE THE COMPRESSOR IS STILL WARM (THERMOSTATIC VALVE OPEN).

NOTE

If the fluid is in poor condition: i.e. it gives off an acrid smell or contains particles of varnish or other solids, the system will have to be rinsed out: pour in around 50% of the normal clean fluid contents, run the set for 3 hours and carefully drain. During rinsing, leave the former fluid filter cartridge in place.

B- Air filter (see Fig. 11, see B Chapter 1)

The air filter is a dry, encapsulated type. In standard conditions of use, change the cartridge every 2 000hrs. This can be done through an easy access from the front panel. Check the cleanliness of the filter every week and change it if necessary.

IMPORTANT

If you do not replace the filtering element when needed, permanent dirt build-up will result. This reduces the air inflow to the compressor and could damage the fluid separator and the compressor.

Fig. 11 - Air filter



C- Turbine

Replacement of the complete fan is recommended if one or more blades are deformed or broken. If replaced, check the fan rotation direction reversal of the rotation direction will reduce machine cooling.

D- Fluid and air cooler

The aluminium fluid and air cooler is a vital part in the compressor system. Please take care of this element. To prevent the nest of tubes from being deformed or damaged, when assembling or disassembling the cooler unions and hoses, the cooler sleeves' must be kept rotating by means of a wrench. The outer surface of the nest of tubes must always be kept clean in order to enable proper heat transfer. In the event of a leak, the source of the leak must be detected. In order to do this:

- Stop the **Compressor**
- Clean the greasy areas.
- Look for leaks using conventional means (soap solution, ...).

E- Fluid separator cartridge (Fig. 12) (see B Chapter 1)

The life time of the fluid separator cartridge will depend on the purity of the intake air, the regular fluid filter replacements, the quality of the fluid used, the care taken when draining the condensation from the fluid tank and on the room temperature.

The fluid separator cartridge (**item. 1 Fig. 12**) should be replaced when the corresponding warning message is displayed on the controller.

After replacing the fluid separator cartridge, reset the counter, which will let you know how much time is left before it needs to be replaced.

Excessive fluid consumption

Excessive fluid in the discharged air and a sudden drop in the level are signs that the fluid separator cartridge has probably deteriorated and must be changed. In the first place, the compressor must be checked to make sure that there are no fluid leaks and that the fluid scavenge line is working properly. The replacement of the fluid separator cartridge requires the removal of the right top panel.

Fig. 12



1. Fluid separator cartridge

F- Fluid return pipe (see Fig. 13)

Placed under the compressor

- Dismantle the complete fluid return check valve.
- Lift the fluid stop valve pipe.
- Check the state of the o-ring (**item. 1 Fig. 13**).
- Reassemble.
- A dedicated kit allows to replace the complete check valve.

G- Draining condensation water (see B Chapter 1)

Condensation water prevents proper lubrication. The resulting substantial wear leads to a reduction in the lifespan of the compressor. It is therefore essential to drain condensation water.

Draining of condensates in the fluid circuit:

Draining will only take place at least 12 hours after the compressor has been shut down. It can be carried out for example at start-up.

Fig. 13 - Fluid return

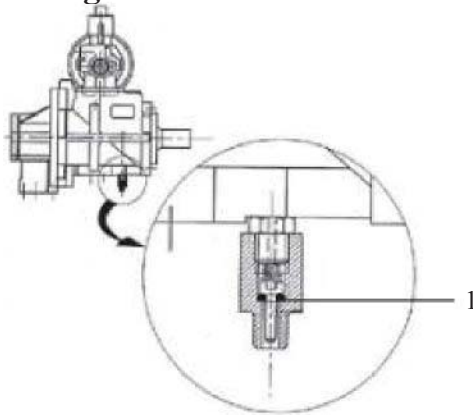

To do this :

- Slowly open the fluid change tap and let the water escape.
- When the fluid appears, close the valve immediately to avoid any Loss.
- Refill with fluid if necessary.

H- Temperature safety tests

IF THE SENSOR DOES NOT DISPLAY THE RIGHT TEMPERATURE OR GIVES AN ERROR MESSAGE ON THE CONTROLLER DISPLAY, FIRST CHECK THE CONNECTIONS AND CABLES. IT CAN ONLY BE REPLACED IF IT HAS BEEN DETECTED FAULTY WITH CERTAINTY.

I- Refastening electric connections

A loosening of the electric power cables leads to the contactors overheating which can lead to their destruction.

PERIODIC REFASTENING IS THEREFORE NECESSARY AT THE STAR/DELTA AND LINE CONTACTOR INPUTS AND OUTPUTS. (SEE MAINTENANCE TABLE).

All electric power supply to the machine must be cut off before opening the electric cabinet.

L-Decommissioning the compressor at the end of its useful life

1. Stop the compressor and close the air outlet valve.
2. Disconnect the compressor from the electric supply.
3. Unload the compressor: unplug the 4/6 piping on the fluid separator cover.
4. Close and unload the section of the air network which is linked to the exit valve. Disconnect from the compressed air exit pipe from the air network.
5. Empty the circuits of fluid and condensates.
6. Disconnect the compressor condensate piping from the condensate draining system.

M- Belt tensioning

Before doing any maintenance, make sure that the compressor is stopped, the power supply and compressed air network are isolated and that the machine is totally blown off.

- Take off the rear panel (1) **Fig. 14**
- Using an Allen Wrench, unscrew the four tightening screws (3) **Fig. 15** of the plunger from the support
- Using an hexagonal wrench, unscrew the lockup nut as shown in the figure
- Tight the belts using a hexagonal wrench, according the **Table 1**. If no tension measuring device is available, use the method shown on **Fig 16**.
- Fix the nut and the locknut using an hexagonal wrench
- Lockup the tightening nut using an Allen Wrench
- Place the rear panel back

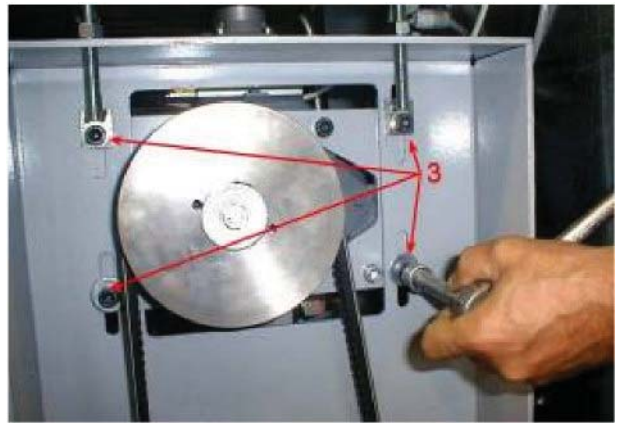

Fig. 15



Fig. 14



Fig. 16

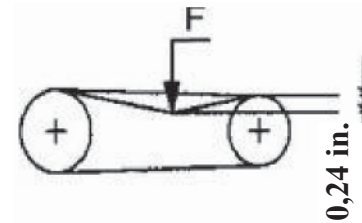

New Belt : $F = 8,8 \text{ lb}$
After 100h : $F = 5,5 \text{ lb}$

N- Belt removal

- Take off the rear panel (1)
- Using an Allen Wrench, unscrew the four tightening screws (3) of the plunger from the support
- Using an hexagonal wrench, unscrew the lockup nut as shown in the **Fig. 18**
- Remove the inlet nozzle **Fig. 19**
- Replace the worn out belts **Fig. 20**
- Tight the belts using a hexagonal wrench, according the **Table 1**. If no tension measuring device is available, use the method shown on **Fig 16**.
- Fix the nut and the locknut using an hexagonal wrench
- Lockup the tightening nut using an Allen Wrench
- Place the rear panel back



Fig. 18



Fig. 19



Fig. 20

Chapter 6-Operating incidents

The staff in charge of maintenance of the compressor must become fully acquainted with this machine, in order to be able to easily diagnose any anomaly. Under normal operating conditions, the compressor must provide full satisfaction.

A - Main incidents

The main incidents likely to occur are listed below, along with the remedies to be applied. The markers of the indicator lights relate to the control panel.

Observed defects	Possible causes	Solutions
1. THE COMPRESSOR DOES NOT START	<ul style="list-style-type: none"> a) Main switch open. b) Phase missing. c) Fuse. d) Insufficient voltage at motor terminals. e) Compressor under pressure. f) Low temperature. 	<ul style="list-style-type: none"> a) Close the switch. b) Check the circuits. c) Replace. d) Check the voltage and the connections. e) Check the vacuum device and change if necessary. Check the water-tightness of the minimum pressure valve. f) Maintain temperature $\geq 35,6$ °F
2. THE COMPRESSOR OVERHEATS	<ul style="list-style-type: none"> a) Ambient temperature too high. b) Obstruction of the passage of cooling through the fluid cooler. c) Fluid level too low. d) Fluid circuit blocked. 	<ul style="list-style-type: none"> a) Make openings or install ducts to evacuate the hot air. b) Clean the cooler. c) Check and top-up fluid level. d) Check that the fluid filter is clean. Drain. Replace the cartridge.
3. THE COMPRESSOR STOPS WHEN THE MOTOR PROTECTION UNIT TRIPS	<ul style="list-style-type: none"> a) Compressor motor overload. b) Phase unbalance. 	<ul style="list-style-type: none"> a) Check the electric connections are tight. Check the pressure of the compressed air and the pressure settings. b) Check the phases currents.
4. OPENING OF SAFETY VALVE	<ul style="list-style-type: none"> a) Dirty separator cartridge. b) Valve of suction box out of use or not closed. c) Faulty pressure switch, sensor or solenoid valve. d) Working pressure too high. 	<ul style="list-style-type: none"> a) Change the separator cartridge. b) Check valve, piston and joints of suction box. c) Check that the pressure switch and solenoid valve and pressure sensor are in good working order.
5. EXCESSIVE FLUID CONSUMPTION	<ul style="list-style-type: none"> a) Blocked fluid retainer. b) Fluid leaks in the compressor. c) Faulty fluid separator element. 	<ul style="list-style-type: none"> a) Check the fluid return pipes. b) Look for fluid leaks and rectify. c) Replace the separator cartridge.
6. DELIVERY PRESSURE TOO LOW	<ul style="list-style-type: none"> a) Incorrect pressure settings. b) The desired output is higher than the one of the compressor. c) Closed suction valve. d) Pressure regulator incorrectly adjusted 	<ul style="list-style-type: none"> a) Adjust the pressure. b) Check consumption and possible leaks. c) Check solenoid valve, pressure setting valve. d) Check setting.
7. COMPRESSED AIR OUTPUT TOO LOW	<ul style="list-style-type: none"> a) Blocked air filter. b) Adjusting solenoid valve not working. 	<ul style="list-style-type: none"> a) Clean filter. b) Check setting.
8. EXCESSIVE NOISE OF UNIT	<ul style="list-style-type: none"> a) Fixing bolts of compressor or motor have come loose. b) Soundproof panels incorrectly closed. c) Transport retainer blocks (red parts) not removed. 	<ul style="list-style-type: none"> a) Tighten. b) Check that they are closed. c) Remove retainer blocks.
9. THE COMPRESSOR STOPS UNTIMELY OR CREATES NON-EXISTING FAULTS	<ul style="list-style-type: none"> a) Electromagnetic disturbance on the Infologic² electronic controller. 	<ul style="list-style-type: none"> a) Add an interference suppression kit (contact the after sales department)

User Manual
Electronic controller

EN

INFOLOGIC²[®]

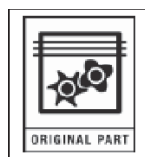
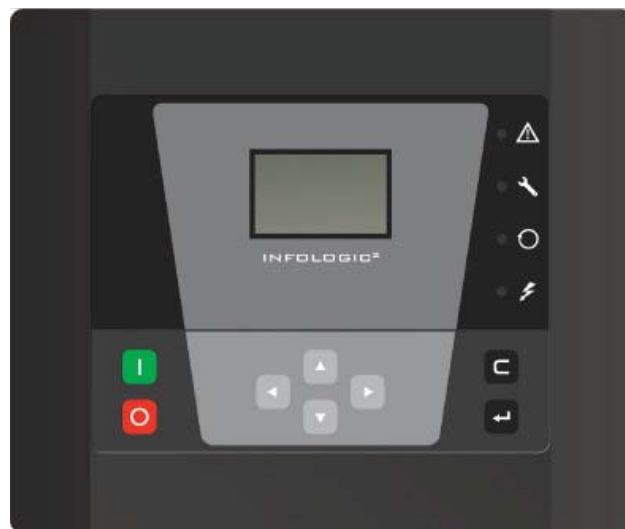

1.0 COMMAND AND CONTROL PANEL



BEFORE CARRYING OUT THE OPERATION TEST, READ CAREFULLY AND ACQUIRE A GOOD KNOWLEDGE OF THE COMMAND FUNCTIONS.

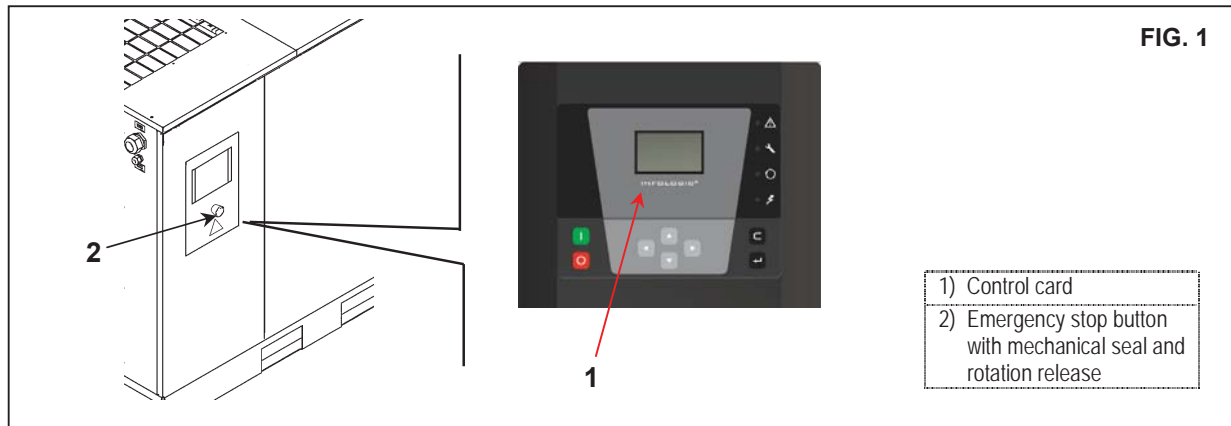

INFOLOGIC² CONTROLLER (Standard controller for fixed speed compressors)

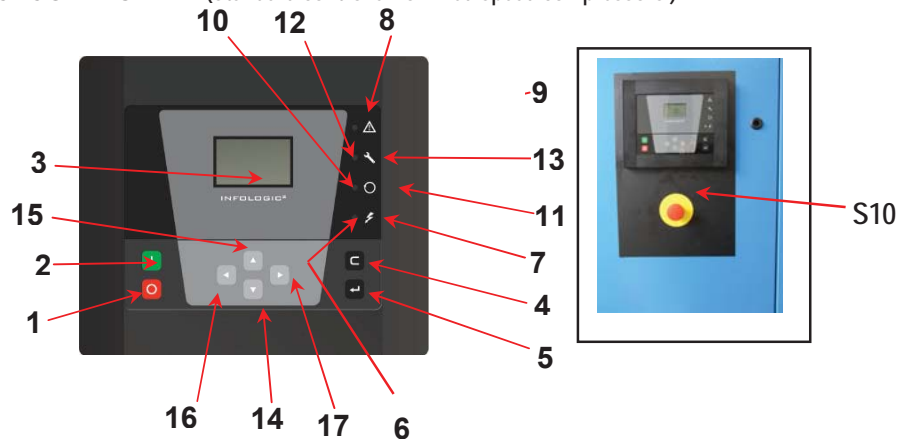

There is an electronic controller on the electric panel ; this controller includes the display of the functions as shown in figure 2.

1	Stop button (0)	10	Automatic operation led
2	Start button (I)	11	Automatic operation symbol
3	Display	12	Service warning led
4	Reset button	13	Service warning symbol
5	Enter key	14	Downward scroll key
6	Voltage on led	15	Upward scroll key
7	Voltage on symbol	16	Left scroll key
8	General alarm led	17	Right scroll key
9	General alarm symbol		



CAUTION: WAIT AT LEAST 45 SECONDS BEFORE STARTING THE MACHINE AFTER SWITCH OFF.

2.0 Introduction:

The Infologic² controller performs the following functions:

- Compressor control
- Compressor protection
- Maintenance monitoring
- Automatic restart after supply interruption (optional).

Automatic control of the compressor

The controller maintains the outlet pressure within defined limits, commanding the load and unload operations of the compressor. Various parameters are considered, among them are: the unload pressure, the load pressure, the minimum stop time and the maximum number of motor starts.

Compressor protection

Shutdown

If element outlet temperature of the element exceeds the programmed shut down level, the compressor will be stopped. This will be indicated on the display (3). The compressor will be stopped also in case of motor overload.

Before remedying, consult the safety precautions.

Shut down warning:













A shut-down warning level is a programmable level below the shut-down level.

If one of the measured quantities exceeds the programmed shut-down warning level, an alarm message will be indicated to warn the operator before the shut-down level is reached.

Service warning:

If the service timer exceeds the programmed value, this will be indicated on the display (3) to warn the operator to perform the required service operations.

Tab. A

Ref.	Name	Description
S3	Emergency stop push button	Push the button to stop the compressor immediately in case of an emergency. After remedying the trouble, unlock the button by pulling it out and press the reset key (4).
1	 Stop button	Push the button to stop the compressor. The led (10) switches off. The compressor will stop after running in unloaded conditions.
2	 Start button	Push the button in order to start the compressor. The led (10) lights up, indicating that the controller is operating automatically the compressor.
3	Display	It shows the operating conditions of the compressor, the actual measured values and the programmed parameters.
4	 Reset button	Button to reset the service timer, a shut-down condition, or in order to return to a previous visualization on the display.
5	 Enter key	Key to select or to confirm a parameter, or to open a sub display.
6	Voltage on led	It indicates that the voltage is switched on
7	 Voltage on symbol	
8	General alarm led	It is lit in case of warning condition. It blinks in case of shut-down or emergency stop condition.
9	 General alarm symbol	
10	Automatic operation led	It indicates that the controller is operating the compressor automatically. The compressor is loaded, unloaded, stopped and restarted depending on the air demand and on the limitations programmed in the controller. The led is lit in during the automatic operations. It blinks when the unit is remotely controlled.
11	 Automatic operation symbol	
12	Service warning led	It is lit in case of service is needed
13	 Service warning symbol	
14	 Downward scroll key	Key to scroll downward through the screens or to decrease a parameter value.
15	 Upward scroll key	Key to scroll upwards through the screens or to increase a parameter value.
16	 Left scroll key	Key to scroll left through the screens.
17	 Right scroll key	Key to scroll right through the screens.













3.0 Display

The display (3) shows :

- The compressor status by means of pictographs.
- The air outlet pressure.
- The actual temperature of the compressor element outlet.
- The actual dew-point temperature in case of compressor equipped with dryer..

The display also shows all measured and programmed parameters.

Pictographs used on the screen (Tab. B)

Ref.	Pictograph	Description
1)		Compressor on status load.
2)		Compressor status unload.
3)		Motor stopped.
4)		When the compressor is stopped, the icon stands still. When the compressor is running, the icon is rotating.
5)		Element outlet temperature.
6)		Dew-point (dryer equipped version).
7)		Motor overload or phase sequence incorrect or outlet element overtemperature detected by temperature switch
8)		Emergency stop activated.
9)		Pictograph: service.
10)		Remote start / stop
11)		LAN control or network setting.
12)		Automatic restart after voltage failure is active
13)		Timer

3.1 Main screen

When the voltage is switched on, the main screen is shown automatically, indicating the operation status of the compressor and the outlet temperature.

example:



The display is showing that the compressor is running loaded (when the horizontal arrow is blinking) and the outlet pressure is 6.8bar.
Consult the service dept. if <test> appears on the display.

4 Shut down warning

A shut-down warning will appear in the event of:

- Too high temperature at the compressor element outlet.
- Too high dew-point temperature for dryer equipped units.

Compressor element outlet temperature

If the compressor temperature of the compressor element exceeds the shut down warning level (105°C / 221°F), the alarm led (8) will light up and the related pictograph will appear blinking.

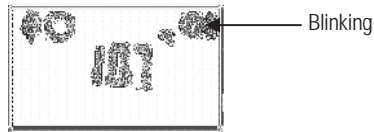

The screen shows that the temperature at the compressor element outlet is 107°C.

Using the keys (14) and (15), it is possible to scroll through other screens to check the actual status of other parameters.

Stop the compressor using the button (1) and wait until the compressor stops.

Open the disconnect switch in the supply line of the compressor.

WARNING:  The unit must be disconnected from the supply net!
Inspect the compressor and remedy.
The message warning will disappear as soon as the warning condition disappears.

Dew-point temperature

For compressors with integrated dryer:

If the dew point temperature exceeds the warning level (not programmable), the alarm led (8) will lit up and the related pictograph will appear blinking.

Main screen with warning dew point temperature

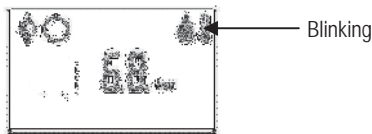

Press the arrow key (14) until the actual dew point appears:



The screen shows that the actual dew-point temperature is 22°C.

Using the keys (14) and (15), it is possible to scroll through other screens to check the actual status of other parameters.

Stop the compressor using the button (1) and wait until the compressor has stopped.

Open the disconnect switch in the supply line of the compressor.

WARNING:  The unit must be disconnected from the supply net!
Inspect the unit and remedy.
The message warning will disappear as soon as the warning condition disappears.

5 SHUT DOWN

The compressor will be shut-down in the following cases:

- The temperature at the outlet of the compressor element exceeds the shut-down level
- Error of the outlet pressure sensor
- Overload of the drive motor

Compressor element outlet temperature

If the outlet temperature of the compressor element exceeds the shut-down level (110°C / 230°F), the compressor will be shut-down, the alarm led (8) will blink, the automatic operation led (10) will switch off.

The following type of screen will appear.



Press the arrow key (14) until the actual compressor element temperature appears:



The screen shows that the temperature at the outlet of the compressor element is 122°C. Open the disconnect switch in the supply line of the compressor.

WARNING:  The unit must be disconnected from the supply net!
Inspect the unit and remedy.

After remedying and when the shut-down condition has disappeared, switch on the voltage and restart the compressor.

Motor overload

In case of motor overload, the compressor will be shut-down, the alarm led (8) will blink, the automatic operation led (10) will switch off and the following type of screen will appear:



Take care that the shut-down "Overload motor" appears in case of main motor overload or incorrect phase sequence (detected by phase sequence relay) or overtemperature detected by temperature switch.

Open the disconnect switch in the supply line of the compressor.

WARNING:  The unit must be disconnected from the supply net!
Inspect the unit and remedy.

After remedying and when the shut-down condition has disappeared, switch on the voltage and restart the compressor.

6 Service warning

A service warning will appear when the service timer has reached the programmed time interval.

The alarm led (12) will light up.

Press the arrow key (14) to reach the screen <d06> with the service symbol.

Push the button (5) and the actual reading of the service timer will appear in <hrs> (or in <x1000hrs> if the service timer value is higher than 9999).



The screen shows that the reading of the service timer is 4002h.

Using the keys (14) or (15), scroll to the screen <d.01> and the running hours symbol will be shown.

Press the key (5) and the actual running hours will appear in <hrs> (or in <x1000hrs> if the value is higher than 9999).



Stop the unit.

Open the disconnect switch in the supply line of the compressor.

WARNING:  The unit must be disconnected from the supply net!
Carry out the service actions. See the preventive maintenance schedule section.
After servicing, reset the service timer. See section Calling up/ resetting service timer.

Visualization of the time since last maintenance

Starting from the main screen:



Press the scroll key (14) until the screen <d.06> appears, then press enter key (5):



This screen shows the unit used is <hrs> (or <x1000 hrs>) and the value 1191: the compressor has run 1191 h since the previous service.

6.1 Resetting the service timer

After servicing, see section Service warning, the timer has to be reset:

Scroll to register screen <d.06> and press enter key (5).

The reading (e.g. 4000) will appear.

Press the enter key (5). If a password is set, enter the password.

The icon will flash (indicating that resetting is possible).

Press the enter key (5) to reset the timer to <0.000> or press reset key (4) to cancel the operation.

7 Scrolling through all screens

Scroll buttons (14) can be used to scroll through all screens. The screens are divided into register screens, measured data screens, digital input screens (numbered as <d.in>, <d.1>, ...), parameter screens (numbered as <P.1>, <P.2>, ...), protections screens (numbered as <Pr.2>, ...) and test screens (numbered as <t.1>, ...).

During scrolling, the numbers of the screens appear consecutively. For most screens, the unit of measurement and the related pictograph are shown together with the screen number.



Example

The screen shows the screen number <d.1>, the unit used <hrs> and the related symbol for running hours. Press Enter key (5) to call up the actual running hours.

7.1 Overview of the screens

Digital input screens	Designation	Related topic
<d.in>	Digital input status	
<d.1>	Running hours (hrs orx 1000 hrs)	
<d.2>	Motor starts (x1 orx 1000)	
<d.3>	Module hours (hrs orx 1000 hrs)	
<d.4>	Loading hours (hrs or x1 000 hrs)	
<d.5>	Load relay (x1 or x 1000)	
<d.6>	Service timer reading (hrs or x 1000 hrs)	
<d.7>	Actual program version	

Parameter screens	Designation	Related topic
<P.1>	Selection between local, remote or LAN control	
<P.2>	Setting a node ID for LAN control and the channels for Mk 4 and Mk 5	
<P.3>	Settings for IP, gateway and Subnet mask	
<P.4>	Pressure band settings	
<P.5>	Setting a pressure band selection	
<P.6>	Modifying a service timer	
<P.7>	Setting of unit for temperature	
<P.8>	Setting of unit for pressure	
<P.9>	Selection for function: Automatic restart after voltage failure	
<P.10>		
<P.11>	Setting of load delay time	
<P.12>	Setting of minimum stop time	
<P.13>	Setting a password	
<P.14>	Remote pressure sensing	

Parameter screens	Designation	Related topic
<Pr.2>	Protections screens	

Test screens	Designation	Related topic
<t.1>	Display test	
<t.2>	Safety valve test	

8 Menu flow

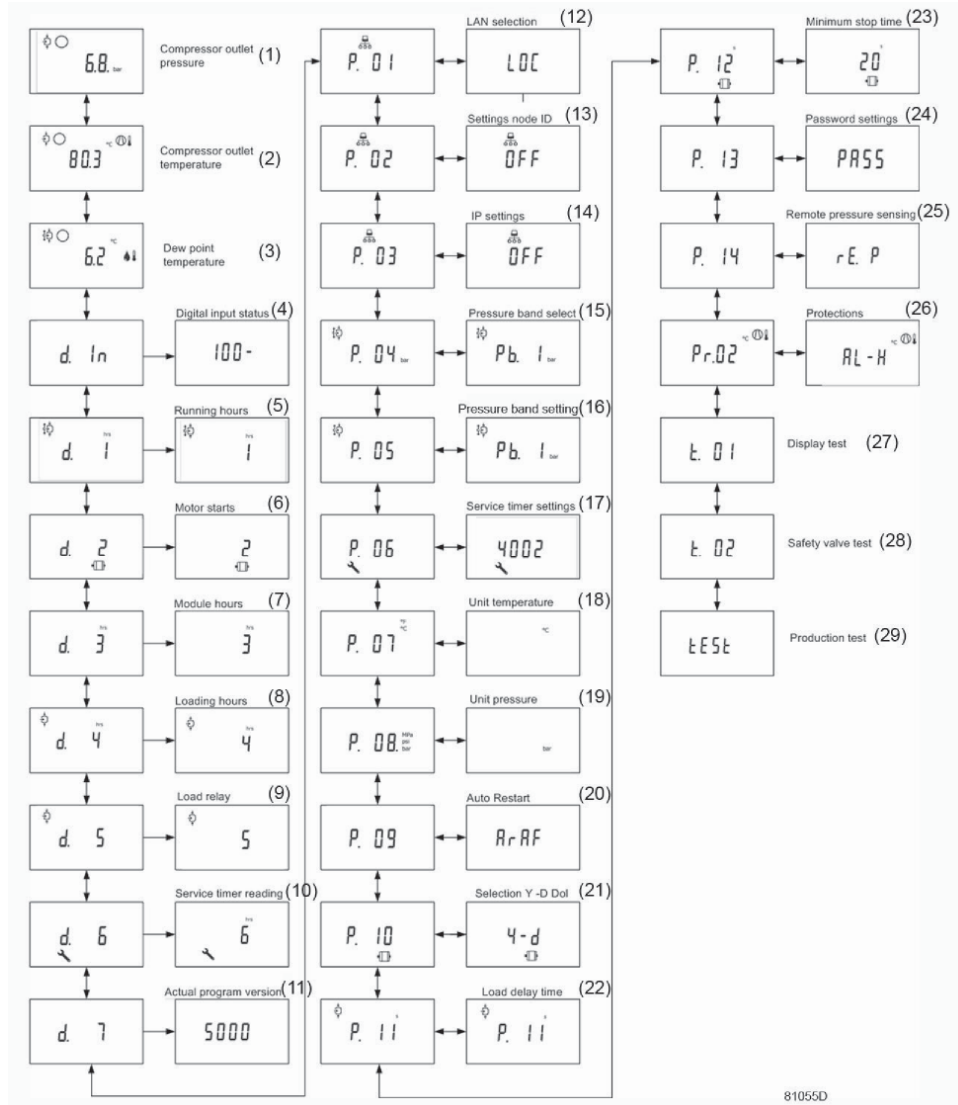

Simplified menu flow

Ref.	Description	Ref.	Description
(1)	Compressor outlet pressure	(16)	Pressure band setting
(2)	Compressor outlet temperature	(17)	Service timer settings
(3)	Dewpoint temperature	(18)	Temperature unit
(4)	Digital input status	(19)	Unit pressure
(5)	Running hours	(20)	Auto restart
(6)	Motor starts	(21)	
(7)	Module hours	(22)	Load delay time
(8)	Loading hours	(23)	Minimum stop time
(9)	Load relay	(24)	Password settings
(10)	Service timer reading	(25)	Remote pressure sensing
(11)	Actual program version	(26)	Protections
(12)	LAN selection	(27)	Display test
(13)	Settings node ID	(28)	Safety valve test
(14)	IP settings	(29)	
(15)	Pressure band selection		

9 Parameters settings

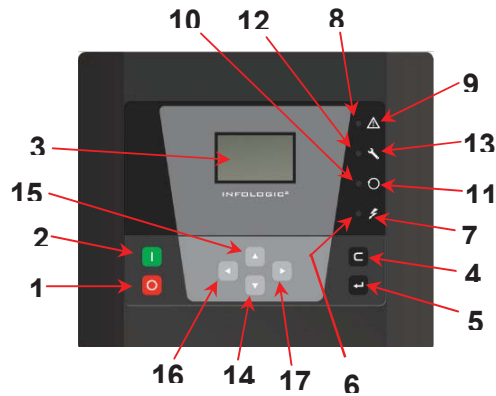

9.1 Selection between local, remote or LAN control

Starting from the Main screen :

- Press arrow key (14) until <P.1> is shown and then press enter key (5). The actually used control mode is shown <LOC> for local control, <rE> for remote control or <LAN> for LAN control.
- Press enter key (5) and if necessary enter the password. The actually control mode is blinking. Use keys (14) and (15) to change the control mode.
- Press enter key (5) to program the new starting mode or press reset key to cancel.

9.2 Calling up node ID and IP for LAN control

Starting from the Main screen :

- Press arrow key (14) until <P.02> is shown and then press enter key (5).
- Press arrow key (14) until <P.03> is shown and then press enter key (5).

9.3 Calling up modifying pressure band settings

Starting from the Main screen :

- Press arrow key (14) until <P.04> is shown and then press enter key (5). Pressure band 1 <Pb.1> is shown on the display, key (14) can be used to scroll to pressure band 2 <Pb.2>.
- Press enter key (5) on desired pressure band. The load level of the selected pressure band appears, key (14) can be used to scroll to the unload level.

Loading pressure

	Psi 92,8	

Unloading pressure

	Psi 101,5	

- Press enter key (5) to modify the load level (value starts blinking). A password may be required. Use keys (14) and (15) to change the load pressure.
- Press enter key (5) to program the new values or press reset key to cancel.

9.4 Modifying pressure band selection

Starting from the Main screen :

- Press arrow key (14) until <P.05> is shown and then press enter key (5). The active pressure band 1 <Pb.1> is shown on the display.

- Press enter key (5) to modify the pressure band selection (a password may be required). The active pressure band <Pb.1 > starts blinking. Press enter key (5) again and with arrow keys select wich pressure band use as default.

9.5 Calling up/modifying unit of temperature

Starting from the Main screen :

- Press arrow key (14) until <P.07> is shown and then press enter key (5). The possible settings are: <°C> and <°F>; the actually used unit is shown.
- Press enter key (5) (unit start blinking) and use arrow keys to select another unit of temperature..
- Press enter key (5) to program the new unit of temperature and press reset key to return to the parameter screens.

9.6 Calling up/modifying unit of pressure

Starting from the Main screen :

- Press arrow key (5) until <P.08> and the possible settings are shown <Mpa>, <psi>, and <bar>, press enter key (5) and the actually used unit is shown.
- Press enter key (5) (unit starts blinking) and use arrow keys to select another unit of pressure.
- Press enter key (5) to program the new unit of pressure and press reset key to return to, the parameter screens.

9.7 Activating automatic restart after voltage failure

Description

This parameter, accessible in screen <P.09>, can only be modified after entering a code. Consult us if this function should be activated.

9.8 Calling up/modifying Load delay time

Starting from the Main screen :

- Press arrow key (14) until <P.11> then press enter key (5).
- Press enter key (5) (value starts blinking) and use arrow keys to modify the value.
- Press enter key (5) to confirm the new value.

9.9 Calling up/modifying Minimum stop time

Starting from the Main screen :

- Press arrow key (14) until <P.12> then press enter key (5).
- Press enter key (5) (value starts blinking) and use arrow keys to modify the value.
- Press enter key (5) to confirm the new value.

10 Activating password protection

Starting from the Main screen :

- Press arrow key (14) until <P.14> and press enter key (5) :

	<PASS>	

- Password <PASS> appears on the screen. Press enter key (5).
- The screen shows the password status on <On> or off <OFF>. Press enter key (5) to modify.
- Change the value with scroll keys (14) and (15).
- Select <On> and press enter key (5).
- Enter the new password and press enter key (5) to confirm.
- Enter the password again and press enter key (5) to confirm.
- <On> appears on the display. Press reset key to return to the parameter screen.

	Lost passwords can not be recovered. Save the password carefully.
---	---

Instruction Manual

EN

Dryers

Type PLUS (A7)

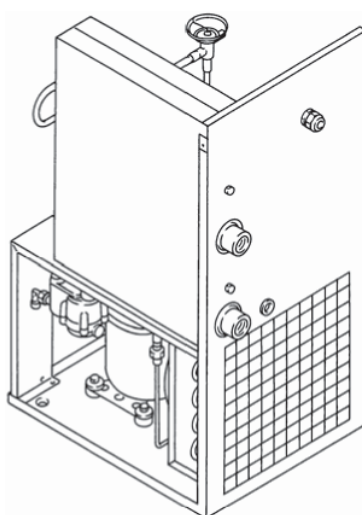

Before carrying out any maintenance, ensure that the compressor has been locked out and tagged out from all power sources



- Integrated dryer

The A7 integrated dryer is a direct expansion refrigeration machine with a dry evaporator. The air to dry is conveyed to the exchanger in which the water vapor is condensed : the water from the condensation is collected in the separator and removed to the exterior.

A - Technical data

1 - Technical features

TYPE	MAX. WEIGHT lb.	POWER SUPPLY V	COOLING LIQUID LOAD «R 404A» lb		NOMINAL POWER W		NOMINAL POWER W		TOTAL POWER W		Intake POWER psi
			50 Hz	60 Hz	50 Hz	60 Hz	50 Hz	60 Hz	50 Hz	60 Hz	
A7	117	230 / 1Ph	1,43	1,43	711	776.5	82	85	793	861.5	188

Reference conditions:

Room temperature: 77 °F
 Air intake temperature: 95 °F
 Service pressure: 101 psi
 Dew point under pressure: 37°F

Service conditions:

Maximum room temperature: 113°F
 Minimum room temperature: 39°F
 Maximum air intake temperature: 131°F
 Maximum operational pressure: 188 psi

Exploded views (fig. 1)

A7

TYPE	Air intake Ø	Air exhaust Ø	Water removal from condensation Ø
A7	1"1/2 Gas F.	1"1/2 Gas F.	1/4"

Fig. 1

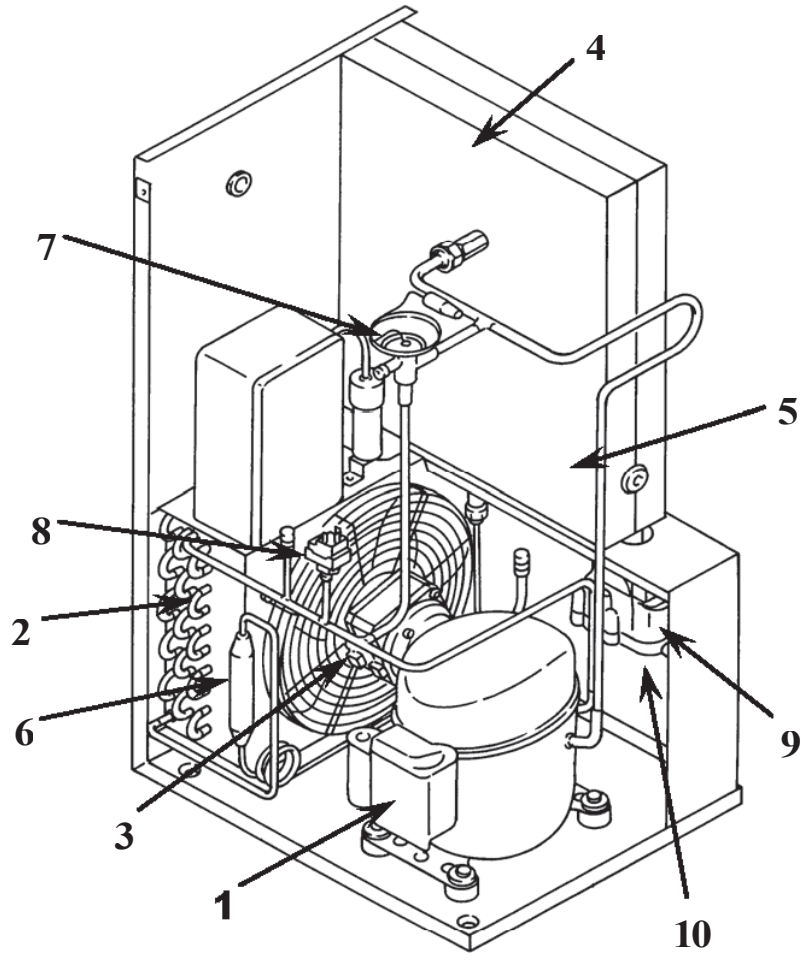

Reference	Description	Reference	Description
1	Cooling compressor	6	Coolant filter
2	Condenser	7	Hot gas by-pass valve
3	Fan	8	Pressure switch
4	Evaporator	9	Condensate bleed solenoid valve
5	Condensate separator	10	Condensate outlet pipe

B - Operation

1 - Operation principle (see Fig. 2)

The gaseous cooling fluid coming from the evaporator (4) is sucked by the cooling compressor (1) in order to be compressed and then cooled in the condenser (2): this enables its condensation, if necessary with the help of the fan (3); the condensed cooling fluid passes through the filter of cooling liquid (8), it expands through the capillary tube (7) and returns to the evaporator, where it produces a cooling effect.

Due to the thermal exchange with the compressed air passing through the evaporator against the flow while cooling, the cooling liquid evaporates and returns to the compressor to start a new cycle. The circuit is completed with a system that bypasses the cooling liquid and adapts the available cooling power to an effective thermal load. This operation is carried out by injecting hot gas under the valve control (9) maintaining the cooling liquid at a constant pressure in the evaporator and therefore the condenser at the same temperature, which never drops below 32 °F degrees in order to prevent the condensates from freezing in the evaporator. Operation of the dryer is completely automatic; the dryer is calibrated in the factory according to a reference dew point and therefore requires no additional calibration.

Key Fig. 2

- | | |
|----|------------------------------------|
| 1 | Cooling compressor |
| 2 | Condenser |
| 3 | Electric fan |
| 4 | Evaporator |
| 5 | Condensate separator |
| 6 | Impurity collector |
| 7 | Capillary tube |
| 8 | Cooling liquid filter |
| 9 | Hot gas by-pass valve |
| 10 | Air-air heat exchanger |
| 11 | Dew point temperature probe |
| 12 | Ventilator control pressure switch |
| B | Automatic level bleed |
| 14 | Timer |

Fig. 2 Operation principle A7

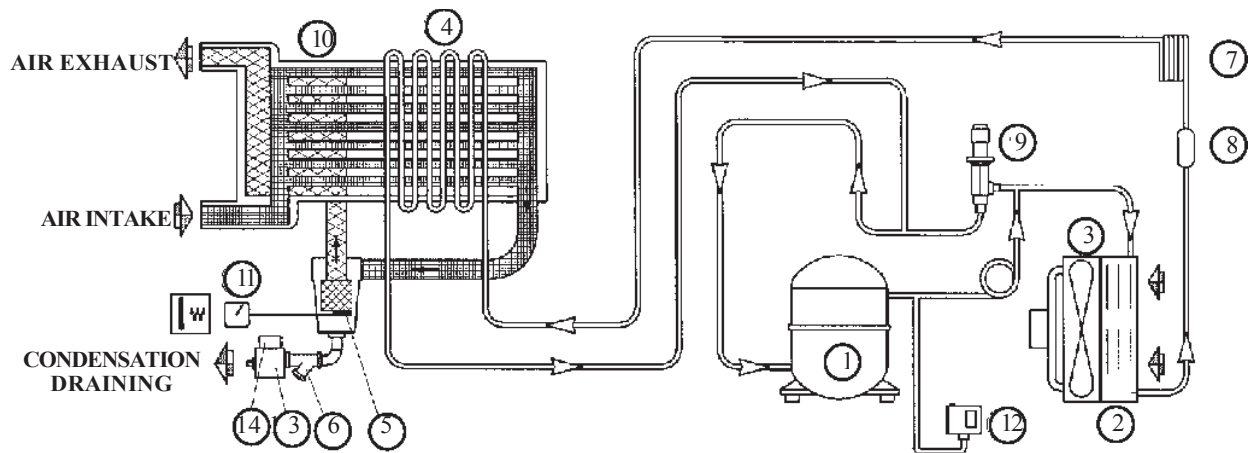

C - Installation

1 - Inspection

Upon receiving the machine, make sure it is intact by checking for any parts that may be visibly damaged. In case of doubt, do not use the machine and contact your customer service department.

2 - Electrical connections

ACCESS TO THE ELECTRIC CABINET IS RESTRICTED TO PROFESSIONALLY QUALIFIED PERSONNEL ONLY. MAKE SURE ALL POWER SUPPLY TO THE UNIT IS DISCONNECTED BEFORE OPENING THE DOOR OF THE ELECTRIC CABINET. IT IS ESSENTIAL THAT YOU RESPECT THE REGULATIONS IN FORCE CONCERNING ELECTRICAL INSTALLATIONS FOR EMPLOYEE SAFETY AND TO PROTECT THE MACHINE.

- Check that the mains voltage corresponds to the voltage specified on the insert.
- Check the condition of the conductors and make sure that there is efficient grounding.
- Check, the upper part of the machine, for the automatic interruption device for overloads with a differential circuit breaker calibrated at 30 mA.

Transformer option for the dryer's internal electrical supply :

- The dryer is factory wired, its electrical supply is plugged in directly to the machine's general supply.

3 - Condensate evacuation

The dryer is fitted with a condensate separator including an automatic bleed to eliminate condensed water after cooling. Connect the evacuation pipe to the condensate collector.

Fig. 3



D - Start up

1 - Preparing for start-up

After carrying out all the checks stipulated in **Chapter 3**, follow the instructions.



BEFORE ANY MAINTENANCE WORK IS CARRIED OUT, THE MACHINE AND THE DRYER MUST BE TURNED OFF, ENSURE THAT THE COMPRESSOR HAS BEEN LOCKED OUT AND TAGGED OUT FROM ALL POWER SOURCES

2 - Stopping and starting

Activate the dryer before starting the air compressor so that it can reach the desired dew point. Only in this way will there not be any condensation water in the compressed air circuit. The dryer must remain in operation for the whole time that the air compressor is running.

IMPORTANT : If the dryer is stopped, wait at least 5 minutes before restarting it to allow the pressure to be balanced. Stopping the dryer is carried out by pushing the dryer control button.

DEPRESSURISATION PROCEDURE

Proceed in the following manner:

- Stop the unit
- Close the insulation valve at the unit's outlet.
- Open the right hand front door
- Depressurize the unit by pressing the "yellow" condensate evacuation button, located on the bleed system. (**Rep. 1 Fig. 3**).

E - Maintenance



BEFORE CARRYING OUT ANY MAINTENANCE, ENSURE THAT THE COMPRESSOR HAS BEEN LOCKED OUT AND TAGGED OUT FROM ALL POWER SOURCES

1 - Periodic maintenance

These maintenance intervals are recommended for well-ventilated places with no dust.

For particularly dusty locations, double the maintenance frequency.

Weekly	Condensate release valve	Clean the filter of the condensate release valve
Monthly	Condenser	Clean the fins to eliminate any dust accumulation

2 - Cleaning the condenser Fig. 4 and 5

The condenser must be cleaned once a month.

Proceed as follows:

- Stop the unit.
- **Cut off the main supply**
- Remove the rear panel (Fig. 4).
- Clean the condenser vanes (Fig. 5) with a jet of air.

Fig 4



Fig 5

DO NOT USE WATER OR SOLVENTS



4 - Shutting off the machine

If the machine is to remain idle for a long time:

- Stop the unit
- Disconnect the electrical supply from the unit
- Close the isolation gates
- Depressurise the unit

During the period of inactivity, the machine must be protected from atmospheric agents, dust and humidity, which could damage the motors and the electrical system.

To start it up again, consult after-sales service.

5 - Disposing of the unit

If the machine is dismantled, it must be separated into equal parts to be recycled or disposed of according to the standards that are currently in force.



WE STRONGLY RECOMMEND FOLLOWING THE STANDARDS THAT ARE CURRENTLY IN FORCE FOR RECYCLING USED FLUIDS AND OTHER POLLUTANTS SUCH AS THE THERMAL INSULATION FOAM AND COOLANT GAS.

F - Trouble shooting and emergency solutions

N.B : THE OPERATIONS SIGNALLED BY .. MUST BE CARRIED OUT BY PROFESSIONALLY QUALIFIED PERSONNEL WHOARE AUTHORISED BY ALUP KOMPRESSOREN.

Observed defects	Possible causes	Solutions
1. The air does not pass through to the dryer's outlet.	The interior tubes are blocked by frost.	<ul style="list-style-type: none"> ▪ ▪ Check that the hot gas by-pass valve is correctly adjusted and in good working order.
2. There is condensed water in the circuit.	a) The operation of the water separator. b) The dryer is operating in bad condensation conditions.	<ul style="list-style-type: none"> ▪ ▪ a) Check that the condensation separator bleed valve works properly. ▪ ▪ b) Check correct operation of the dryer and its fan.
3. Continuous leak of air and water from the condensation separator.	Defective automatic condensation bleeding system.	<ul style="list-style-type: none"> ▪ ▪ Check the system.
4. The top of the dryer's compressor is very hot (> 131°F).	a) See 2b. b) The refrigeration circuit does not work with the correct amount of gas.	<ul style="list-style-type: none"> ▪ ▪ Check all coolant gas leaks. ▪ ▪ Refill the coolant gas.
5. The motor works intermittently because of the protection thermostat.	See 2b. See 4.	
6. The dryer's motor groans but will not start.	a) Defective electrical connections. b) You have stopped and restarted the dryer without waiting for the pressure readjustment. c) The dryer motor starting system is defective.	<ul style="list-style-type: none"> a) Check the condition and tightness of the electrical connections. b) Wait a few minutes before restarting the dryer. ▪ ▪ c) Check the operation of the relay and the operation of the condensers and engine start up (possible).
7. The dryer has stopped and will not restart, even after a few minutes.	a) Fuses b) The thermostatic protection with manual starting has begun to operate. See case 2b and 4. c) The high-pressure switch has begun operation. d) The motor is out of order.	<ul style="list-style-type: none"> a) Check the fuses. b) Reload or wait for the head of the compressor to cool down. c) Reload the pressure switch. d) Check the integrity of the electrical connection and its insulation.
8. The dryer's compressor makes too much noise.	Problems with the internal mechanical organs or with the compressor valves.	
9. The condensation separator does not work.	Automatic condensation bleeding system is cleaned.	Bleed the unit by opening the manual bleed valve. Have the system checked.
10. Dew point under too much pressure.	a) Room temperature is too high. b) Lack of coolant. c) Cooling compressor does not work. d) Evaporator pressure is too high. e) Condenser pressure is too high.	<ul style="list-style-type: none"> a) Check and correct the cooling air inlet if required. ▪ ▪ b) Make sure the circuit is watertight, have it recharged. c) Check the dryer electricity supply. d) See 11. e) See 12.
11. Evaporator pressure is too high.	a) Maladjustment or breakdown of the by-pass valve of the hot coolant gas. b) Condenser pressure either too high or too low. c) Lack of coolant.	<ul style="list-style-type: none"> ▪ ▪ a) Have the by-pass valve readjusted. b) See 12. ▪ ▪ c) Make sure the circuit is watertight, have it recharged.
12. Condenser pressure is too high.	a) Defective fan pressure switch. b) Defective fan. c) Room temperature is too high. d) Condenser is clogged on the outside.	<ul style="list-style-type: none"> ▪ ▪ a) Carry out a replacement of the part. b) Check the fan. c) Check and correct the cooling air inlet if required. d) Clean the condenser fins.

