

 **Ruffneck**TM
Heaters for the Harshest Environments

Heaters for the
Harshest Environments

Contents

Products Overview & Locations	
Locations	3
Catalogues at a Glance	4
Explosion-Proof Electric Unit Heaters	
FX5	6
FX5-SD	12
FE2	18
Explosion-Proof Convection Heaters	
CX1 ProVector®	24
CF1 ProVector®	31
Corrosion-Resistant Washdown Unit Heaters	
CR1 Triton™	35
CRE1 Triton™	39
Regular Duty Unit Heaters	
RGE Regular Duty	43
Heavy Duty Unit Heaters	
RGX Heavy Duty	46
Explosion-Proof Duct Heaters	
RXDF	49
Commercial Duct Heaters	
RDFF, RDIF, RDFT & RDIT	54
Heat Exchanger Unit Heaters	
FR	57
HP	65
Advanced Series Unit Heaters	
AH / AV	76
Explosion-Proof Exhaust Fan	
EFX	92
EFX Accessories	96
Disconnect Switch	
XS	97
Thermostats	
XT-311, XT-312 Defender®	98
XT-411 Defender®	99
ET5-S, XTB, XTWA, XTD8-S	100
Mounting Kits	
BMK, PMK, WMK, HMK, SHMK	101
Reference	
Thermal Performance Analysis Service	102
Technical Data	
Technical Data	103
Hazardous Location Definitions	
Hazardous Location Definitions	106
Reference	
Warranty	109



Edmonton, Alberta



Houston, Texas



Orillia, Ontario



Oakville, Ontario



Denver, Colorado

As a leader in heating and filtration solutions, CCI Thermal Technologies Inc. is committed to ongoing research, product development and above all, excellence in customer service. With facilities across North America, CCI Thermal manufactures seven of the top brands in industrial heating in addition to a comprehensive line of engineered industrial filtration products including:

Cata-Dyne™ [Explosion-Proof Gas Catalytic Heaters](#)

Ruffneck™ [Heaters for the Harshesht Environments](#)

Caloritech™ [Engineered Electric Heat](#)

3L Filters™ [Engineered Filtration Systems](#)

Norseman™ [Electric Explosion-Proof Heaters](#)

DriQuik™ [Infrared Oven Components](#)

Fastrax® [Track and Switch Heaters](#)

Ruffneck™, a key brand of CCI Thermal Technologies Inc., has a broad product line including heat-exchanger unit heaters, explosion-proof electric air heaters, industrial electric air heaters and explosion-proof thermostats. Established in 1975, Ruffneck™ has a long and proud history of supplying quality products to a worldwide customer base. All products are designed for rugged, industrial applications and Ruffneck™ is well known for its "ship the heat in a week" policy in which 95% of all standard orders are shipped within one week. Ruffneck™ has enhanced CCI Thermal Technologies Inc.'s position as one of North America's leading manufacturers of industrial heating equipment.

We invite you to visit www.ccithermal.com to view the broad range of innovative industrial heating products manufactured by CCI Thermal Technologies Inc.

Locations

Caloritech™ Catalog: Section A
Elements and Specialty Heaters

Calvane™ heaters, tubular heaters, bolt heaters, tubular band heaters, mitosis heaters, finned tubular heaters, cartridge heaters, strip and finned strip heaters, hot plate/drum heaters, cast-in heaters, transit heaters.



Caloritech™ Catalog: Section D
Engineered Products

circulation heaters, heat transfer systems, custom engineered products, panel heaters, control panels, technical data.

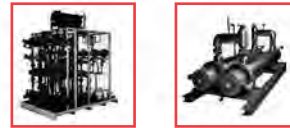

Caloritech™ Catalog: Section B
Immersion Heaters

screwplug heaters, domestic immersion heaters, urn heaters, flange heaters, over-the-side heaters, pipe insert heaters, gate and gain heaters.



Caloritech™ Catalog: Section E
Boilers

hot water boilers, steam boilers, condensate receiver packages, blow off tanks, packaged circulation heaters, calorifiers.

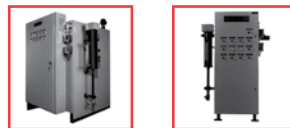

Caloritech™ Catalog: Section C
Air and Space Heaters

infrared radiant heaters, panel heaters, convection heaters, commercial and explosion-proof duct heaters, unit heaters, gate and gain heaters.



Caloritech™ Catalog: Section F
Controls

electronic controls, industrial thermostats, explosion-proof thermostats, thermostats, thermocouples and thermowells, x-Max® explosion-proof housings.

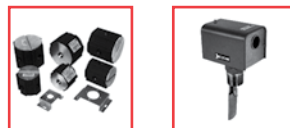

Catalogues at a Glance

Cata-Dyne™ Catalog

explosion-proof infrared gas catalytic heaters, high temperature industrial infrared heaters, infrared gas catalytic heating systems, accessories.



Fastrax® Catalog

track and switch heaters, custom designed automated control systems, accessories.

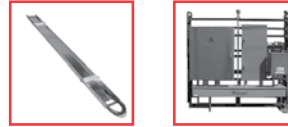

Ruffneck™ Catalog

explosion-proof electric air heaters, heat-exchanger unit heaters, corrosion-resistant washdown unit heaters, convection heaters, thermostats.



DriQuik™ Catalog

long, medium and short wavelength infrared oven components and control panels.

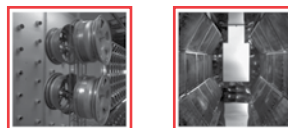

3L Filters™ Catalog

filters, strainers, separators, dehydrators, fuel monitors, clay treaters, head lifts, closures, pressure vessels, engineered products, nuclear, aviation general industrial products.

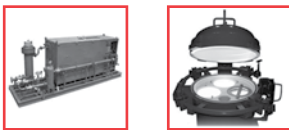

CCI Thermal Technologies Inc.

Putting Safety First

CCI Thermal Technologies Inc. has always been committed to the safety and well being of our customers. We are familiar with the safety regulations of heating products in a wide variety of environments and ensure that our products meet or exceed the requirements for their applications. CCI Thermal Technologies Inc. takes great pride in its lines of certified products.

Visit us at www.ccithermal.com

Our website offers on-line PDF catalogs, product specifications, installation manuals, and technical documentation 24 hours a day. Additionally, you will find easy access to anyone of our factory representatives, regional sales managers or customer service personnel.

Quality

All our business processes are steered by the principles of ISO 9001 and ASME, providing an operational framework that places emphasis on continual improvement and customer satisfaction.

Norseman™ Catalog

natural convection explosion-proof heaters, forced air explosion-proof heaters, thermostats.



Catalogues at a Glance

FX5 Explosion-Proof Electric Air Heaters

Ruffneck™ FX5 heaters are cUL_{US} certified for use in hazardous locations. They are designed for the harshest environments such as: dry indoor industrial applications, oil refineries, petrochemical plants, pulp and paper mills, grain elevators, hazardous waste storage facilities,



parts. All fasteners are zinc plated for corrosion protection.

Ruffneck™ heaters are built to last. All Ruffneck™ products are subjected to exhaustive technical analysis and testing during design and development, and are manufactured under a registered quality assurance program. As a result, they have consistently proven their safety and reliability.



wastewater treatment plants, etc., where specific explosive gases or dusts may be present.

The FX5 offers a larger junction box for easier installation, additional limit controls and a heavy duty core.

For hazardous location heating, rely on the Ruffneck™ FX5 heater for the most dependable, trouble-free service available.

Suitable for the following hazardous location classifications:

- Class I, Divisions 1 & 2, Groups C & D
- Class II, Division 1, Groups E, F & G
- Class II, Division 2, Groups F & G
- Class I, Zones 1 & 2, Groups IIA & IIB
- Temperature Code T3B 329°F (165°C)



The heater core assembly is contained in a sturdy, epoxy-coated 12-gauge steel cabinet, which also carries the motor and fan assembly. Adjustable louvres allow directional control of the airflow. A narrow gap, two-piece fan guard is provided to shield all moving

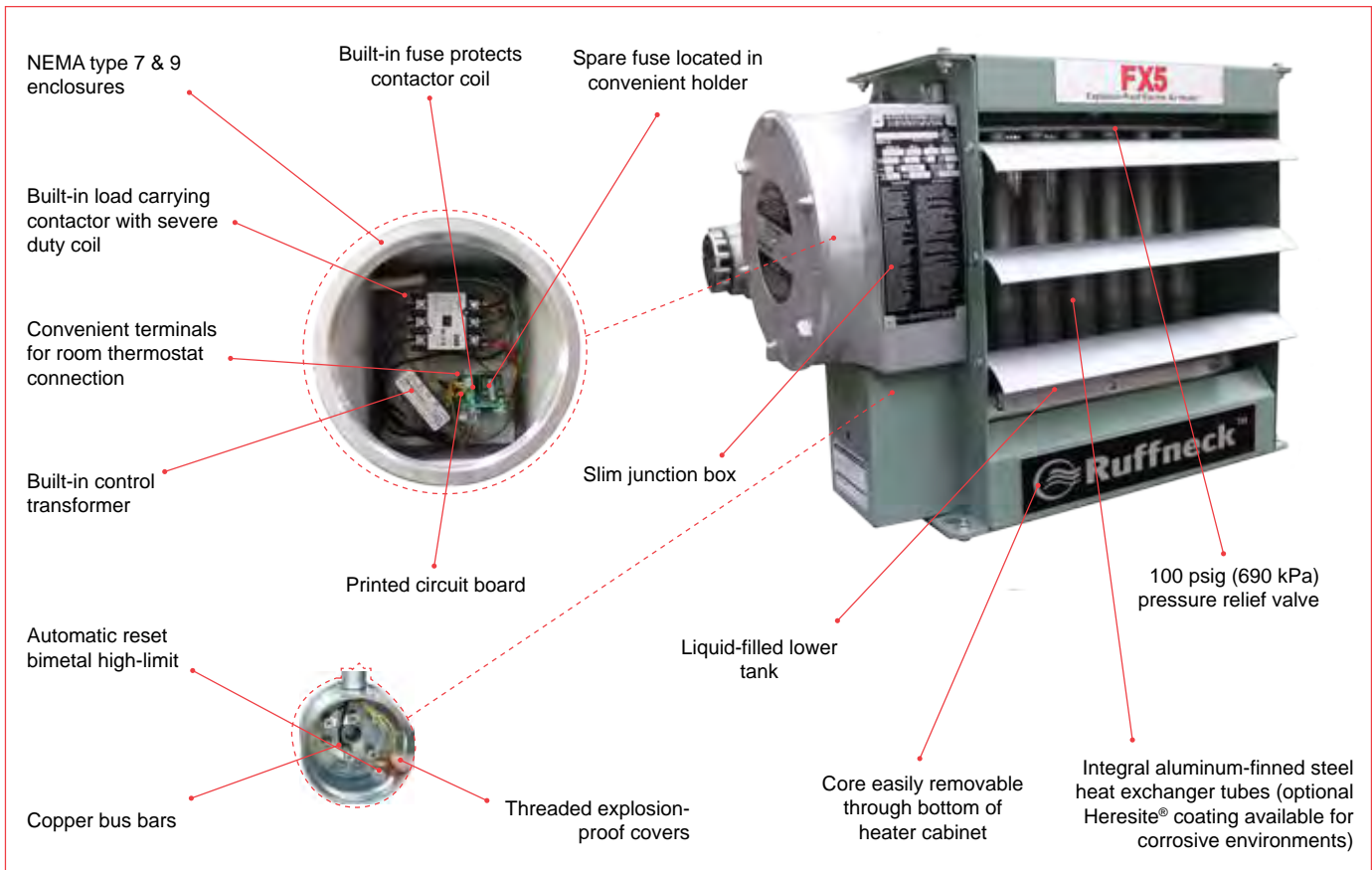

Heresite® is a registered trademark of Heresite® Protective Coatings Inc.

FX5

Performance Data for 60 Hertz FX5
c UL_{us} Temperature Code T3B 165°C (329°F)

NOMINAL WATTAGE (kW)	MODEL	VOLTAGE	PHASE	TOTAL CURRENT (A)	OPTIONAL BUILT-IN DISCONNECT SWITCH	AIR TEMPERATURE RISE		Btu/hr
						°F	°C	
3	FX5-208160-030	208	1	18.5	DS5	19.0	10.5	10,250
	FX5-208360-030	208	3	10.6				
	FX5-240160-030	240	1	16.6				
	FX5-240360-030	240	3	9.6				
	FX5-480160-030 °	480	1	7.1				
	FX5-480360-030	480	3	4.8				
	FX5-600360-030	600	3	3.6				
5	FX5-208160-050	208	1	28.1	DS5	31.6	17.6	17,050
	FX5-208360-050	208	3	16.2				
	FX5-240160-050	240	1	24.9				
	FX5-240360-050	240	3	14.4				
	FX5-480160-050 °	480	1	11.2				
	FX5-480360-050	480	3	7.2				
	FX5-600360-050	600	3	5.5				
7.5	FX5-208160-075	208	1	40.2	DS5	27.9	15.5	25,600
	FX5-208360-075	208	3	23.1				
	FX5-240160-075	240	1	35.4				
	FX5-240360-075	240	3	20.5				
	FX5-480160-075 °	480	1	16.4				
	FX5-480360-075	480	3	10.2				
	FX5-600360-075	600	3	7.9				
10	FX5-208160-100*	208	1	52.2	Not Available	37.2	20.6	34,100
	FX5-208360-100	208	3	30.1	DS5			
	FX5-240160-100	240	1	45.8	DS5			
	FX5-240360-100	240	3	26.5	DS5			
	FX5-480160-100 °	480	1	21.6	DS5			
	FX5-480360-100	480	3	13.2	DS5			
	FX5-600360-100	600	3	10.3	DS5			
15	FX5-208360-150	208	3	44	DS5	27.1	15.1	51,200
	FX5-240160-150*	240	1	66.6	Not Available			
	FX5-240360-150	240	3	38.5	DS5			
	FX5-480160-150 °	480	1	32.1	DS5			
	FX5-480360-150	480	3	19.3	DS5			
	FX5-600360-150	600	3	15.2	DS5			
20	FX5-480160-200 °	480	1	42.5	DS5	36.1	20.1	68,250
	FX5-480360-200	480	3	25.3	DS5			
	FX5-600360-200	600	3	20	DS5			
25	FX5-480360-250	480	3	31.3	DS5	22.0	12.2	85,300
	FX5-600360-250	600	3	24.8	DS5			
30	FX5-480360-300	480	3	37.3	DS5	26.4	14.6	102,350
	FX5-600360-300	600	3	29.6				
35	FX5-480360-350	480	3	43.3	DS5	30.7	17.1	119,450
	FX5-600360-350	600	3	34.4				

Consult Terms & Conditions of Sale (or the FX5 Owner's Manual) for warranty information.

Note: (*) Exceeds the 48 amp circuit limit of NEC 424-22

(*) 480V 1 Phase units are certified Class I, Div. 1, Group D and Class II, Div.1, Groups F and G.

- Minimum conductor size for 86°F (30°C) ambient. Derate conductor for ambient temperature. Use minimum 194°F (90°C) insulation.
- Heater is functioning normally if at rated voltage the amp draw is within 10% of the value in this table.
- Operation at lower voltages will result in reduced heat output and amp draw
- Add "T" to model number when adding a built-in thermostat
- Add "D" to model number when adding a built-in disconnect switch
- Add "P" to model number when adding a built-in pilot light
- Add "S" to model number when adding a 3-way switch
- Add "H" to model number for units with high "off" (deenergized) ambient temperatures
- Add "U" to model number for units with continuous fan option.
- Add "A" to model number for units with stainless steel cabinet.
- Add "L" to model number for units with pilot and 3-way switch or large box option.
- Add "B" to model number for units with low ambient option (down to -58°F or -50°C).

See page 10 for model coding.

See page 8 for installation conditions.

FX5

Performance Data for 50 Hertz FX5

NOMINAL WATTAGE (kW)	MODEL	VOLTAGE	PHASE	TOTAL CURRENT (A)	OPTIONAL BUILT-IN DISCONNECT SWITCH	AIR TEMPERATURE RISE		Btu/hr
						°F	°C	
2.5	FX5-220150-025	220	1	16.1	DS5	19.7	11.0	8,550
4.2	FX5-220150-042			23.8	DS5	33.2	18.4	14,350
6.3	FX5-220150-063			33.3	DS5	28.5	15.7	21,500
8.4	FX5-220150-084			42.9	DS5	37.8	21.1	28,700
12.6	FX5-220150-126*			62.0	Not Available	27.5	15.2	43,000
2.8	FX5-230150-028	230	1	16.3	DS5	22.1	12.3	9,550
4.6	FX5-230150-046			24.1	DS5	36.4	20.2	16,000
6.9	FX5-230150-069			34.1	DS5	31.1	17.2	23,550
13.8	FX5-230150-138*			64.1	Not Available	30.1	16.6	47,100
2.5	FX5-380350-025	380	3	4.9	DS5	19.7	11.0	8,550
4.2	FX5-380350-042			7.5		33.2	18.4	14,350
6.3	FX5-380350-063			10.7		28.5	15.7	21,500
8.4	FX5-380350-084			13.9		37.8	21.1	28,700
12.5	FX5-380350-125			20.1		27.2	15.1	42,700
20.9	FX5-380350-209			32.9		22.0	12.1	71,350
2.8	FX5-400350-028	400	3	5.1	DS5	22.1	12.3	9,550
4.6	FX5-400350-046			7.7		36.4	20.2	15,700
6.9	FX5-400350-069			11.1		31.1	17.2	23,550
9.3	FX5-400350-093			14.5		42.0	23.2	31,750
13.9	FX5-400350-139			21.2		30.2	16.7	74,450
18.5	FX5-400350-185			27.8		40.2	22.3	63,150
23.1	FX5-400350-231			34.5		24.2	13.5	78,850
3.7	FX5-415350-037	415	3	6.4	DS5	29.3	16.3	12,650
7.5	FX5-415350-075			11.6		33.8	18.7	25,600
14.9	FX5-415350-149			22.0		32.5	18.1	50,850
22.4	FX5-415350-224			32.4		23.5	13.1	76,450
4.2	FX5-440350-042	440	3	6.7	DS5	33.2	18.4	14,350
8.4	FX5-440350-084			12.2		37.8	21.1	28,700
16.8	FX5-440350-168			23.3		36.5	20.3	57,350
20.9	FX5-440350-209			28.7		22.1	12.2	71,350

Notes:

1. Minimum conductor size for 86°F (30°C) ambient. Derate conductor for ambient temperature. Use minimum 194°F (90°C) insulation.
2. Heater is functioning normally if at rated voltage the amp draw is within 10% of the value in this table.
3. Operation at lower voltages will result in reduced heat output and amp draw
4. Add "T" to model number when adding a built-in thermostat
5. Add "D" to model number when adding a built-in disconnect switch
6. Add "P" to model number when adding a built-in pilot light
7. Add "S" to model number when adding a 3-way switch
8. Add "H" to model number for units with high "off" (deenergized) ambient temperatures
9. Add "U" to model number for units with continuous fan option.
10. Add "A" to model number for units with stainless steel cabinet.
11. Add "L" to model number for units with pilot and 3-way switch or large box option.
12. Add "B" to model number for units with low ambient option (down to -58°F or -50°C).

Installation Conditions:

1. The FX5 Series Electric Air Heaters are for dry indoor use only. Do not immerse in water. Do not store or use in areas exposed to rain or snow.
 2. The FX5 heaters are to be used only in atmospheres having an ignition temperature higher than 329°F (165°C).
 3. Altitude restrictions apply - see specifications on next page.
 4. Heaters should be connected to a fixed power supply and must be permanently mounted in a level, upright position during operation.
 5. Read and be aware of the terms of our Warranty located in the owner's manual.
 6. Refer to Owner's Manual.
- Note: (*) Exceeds the 48 amp. circuit limit of NEC 424-22.**

Specifications for 60 Hertz FX5

60 HERTZ		FX5										
NOMINAL KW		3	5	7.5	10	15	20	25	30	35		
Maximum Altitude	(ft)	12,000	8,000	10,000	7,000	10,000	7,000	10,000	7,000	6,000		
	(m)	3,658	2,438	3,048	2,134	3,048	2,134	3,048	2,134	1,829		
Air Delivery @ 70°F	(CFM)	500		850		1,750		3,600				
	@ 21°C (m³/hr)	850		1,444		2,973		6,116				
Horizontal Throw	(ft)	15		30		40		70				
	(m)	4.6		9.1		12.2		21.3				
Maximum Mounting Height (to underside)	(ft)	7		10		10		20				
	(m)	2.1		3.0		3.0		6.1				
Motor Power*	(HP)	1/2			1/2			1/2				
	(kW)	0.373			0.373			0.373				
Motor Speed	(RPM)	1,725			1,725			1,725				
Fan Diameter	(in)	12			16			20				
	(mm)	305			406			508				
Net Weight		without DS5		with DS5		without DS5		with DS5		without DS5		with DS5
	(lbs)	148		160		177		189		212		224
	(kg)	67.1		72.5		80.2		85.6		96.2		101.6
Shipping Weight	(lbs)	202		214		227		239		263		275
	(kg)	91.6		97		102.9		108.3		119.3		124.7

See page 11 for general specifications common to all FX5 models. Weights are an approximate maximum.
 Manufacturer reserves the right to replace motors with suitable alternates.

Specifications for 50 Hertz FX5

50 HERTZ		FX5										
NOMINAL KW		2.5	3.7 & 4.6	6.3 & 7.5	8.4	12.5 & 12.6	14.9 & 16.7	20.9	22.4			
Maximum Altitude	(ft)	12,000	8,000	10,000	7,000	10,000	7,000	10,000	7,000			
	(m)	3,658	2,438	3,048	2,134	3,048	2,134	3,048	2,134			
Air Delivery @ 71°F	(CFM)	400		700		1,450		3,000				
	@ 21°C (m³/hr)	679		1,189		2,463		5,096				
Horizontal Throw	(ft)	13		25		35		60				
	(m)	4.0		7.6		10.7		18.2				
Maximum Mounting Height (to underside)	(ft)	7		10		10		20				
	(m)	2.1		3.0		3.0		6.1				
Motor Speed	(RPM)	1,437			1,437			1,437				
Motor Power*	(HP)	1/2			1/2			1/2				
	(kW)	0.373			0.373			0.373				
Fan Diameter	(in)	12			16			20				
	(mm)	305			406			508				
Net Weight		without DS5		with DS5		without DS5		with DS5		without DS5		with DS5
	(lbs)	148		160		177		189		212		224
	(kg)	67.1		72.5		80.2		85.6		96.2		101.6
Shipping Weight	(lbs)	202		214		227		239		263		275
	(kg)	91.6		97		102.9		109.3		119.3		124.7

See page 11 for general specifications common to all FX5 models. Weights are an approximate maximum.
 * Manufacturer reserves the right to replace motors with suitable alternates.

FX5

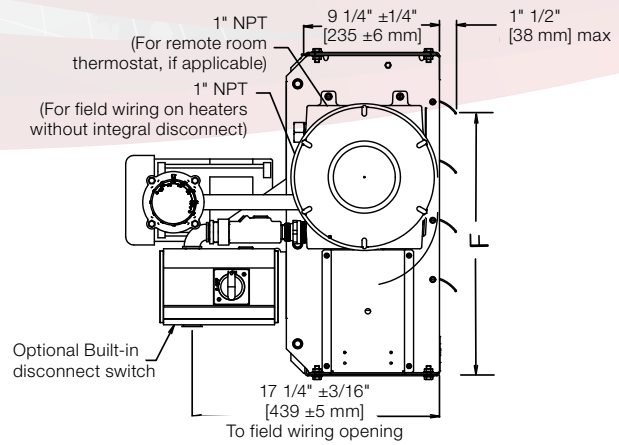
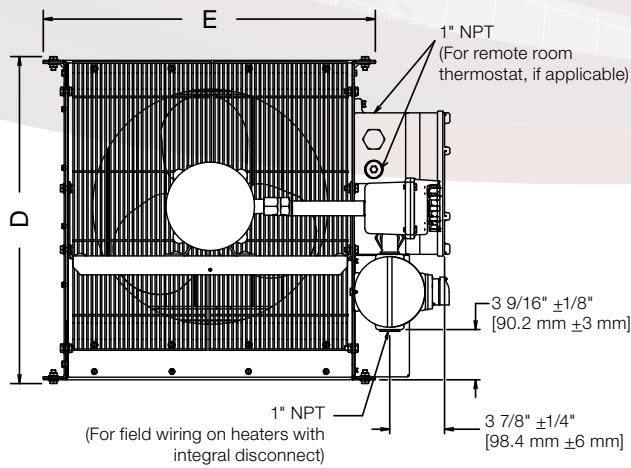

Dimensional Tolerances $\pm 1/8"$ [± 3 mm]
Unless otherwise specified.

DIM.	kW	kW			DIM. TOL. \pm
		2.5-10	12.5-20	20.9-35	
A	in.	7	7	7	1/8
	mm	178	178	178	3
B	in.	18-3/16	22-5/16	26-1/4	1/8
	mm	462	566	667	3
C	in.	27	31	35	3/16
	mm	686	787	889	4
D	in.	19	23	27	1/8
	mm	484	586	688	3
E	in.	19-7/16	23-7/16	27-7/16	3/8
	mm	492	596	697	10
F	in.	17-1/2	19-1/2	21-13/16	5/16
	mm	444	495	554	8
G	in.	24-5/8	28-5/8	32-5/8	3/16
	mm	625	727	828	4

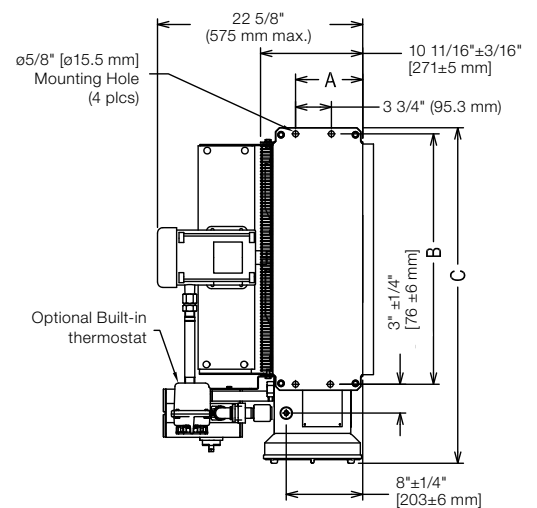
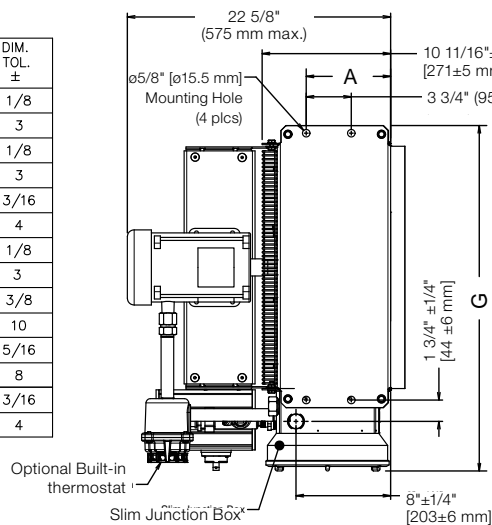

Model Coding

FX5 - 480 3 60 - 350 - W - T

Model Series | Heater Voltage (208V, 240V, 480V, 600V) | Hertz (50, 60) | Heater Kilowatts (350) | Welded Core | Thermostat (T)

5th Generation | Phase (1, 3)

T - XT-311 Thermostat with slim junction box
 XT-411 Thermostat with large junction box
 D - Built-in disconnect
 P - Built-in pilot light
 S - 3-way switch

H - Unit with high "off" de-energized ambient temperatures
 C - Heresite® coating
 A - Stainless steel cabinet
 U - Continuous fan
 B - Low ambient option -58°F (-50°C)
 L - Large junction box

FX5

FX5 General Specifications

Approvals	
Hazardous Locations Classifications	Class I, Divisions 1 & 2, Groups C & D Class II, Divisions 1, Groups E, F & G Class II, Divisions 2, Groups F & G Class I, Zones 1 & 2, Group IIA & IIB Temperature Code T3B 329°F (165°C)
Motor Type	Explosion-proof. Thermally protected. Permanently lubricated ball bearings
Fan	Aluminum blade. Steel spider and hub with 5/8" (15 mm) bore
Fan Guard	Split design with close wire spacing. 1/4" (6.3 mm) diameter probe will not enter
Mounting Holes	Four 5/8" (15.9 mm) diameter holes at the top
Heating Elements	Long-life metal-sheathed elements
Temperature High-Limit	Automatic reset type, snap-action bimetal, open on temperature rise. Rated 100,000 cycles at 10 amp, handles 0.128 amps, plus an additional ambient high limit
Control Circuit	120V, 0.128 amps, 15VA. (Grounded)
Optional Built-in Thermostat	Explosion-proof 36°F to 82°F (2°C to 28°C)
Control Transformer	Multiple voltage primary, 120V secondary, 50VA
Contactors	75 amp. Rated for 500,000 mechanical operations. 120V, 15VA coil (separately fuse-protected)
Cabinet Material	12-gauge (0.104" / 2.6 mm) epoxy powder coated steel. Optional Heresite® coating available for corrosive atmospheres with an optional stainless-steel casing
Core	HD Core (Partially filled with Propylene Glycol)
Conduit Material	Heavy wall, 0.122" (3 mm), steel
Overpressure Protection	Preset 100 psig (690 kPa) pressure relief valve, aluminum body, no serviceable parts
Operational Temperature Range	-4°F to 104°F (-20°C to 40°C); for "B" units -58°F to 104°F (-50°C to 40°C)
Large Junction Box (H x W x D)	10.25" (230 mm) x 8.00" (180 mm) x 9.12" (205 mm)
Slim Junction Box (H x W x D)	10.25" (230 mm) x 8.00" (180 mm) x 6.75" (172 mm)
Field Connection	Two 1" NPT
Weight (for 15 kW unit)	177 lbs (80.36 kg)
Weight with disconnect (for 15 kW unit)	189 lbs (85.82 kg)
Optional Built-in Disconnect Switch	DS5 uses <i>x-Max</i> ® construction
Optional Pilot Light	Explosion-proof light fixture with replaceable bulb
Optional 3-Way Switch	Explosion-proof 3 position fan switch (on, off, fan only)

FX5

FX5-SD Severe Duty Explosion-Proof Electric Air Heaters

The FX5-SD is the next generation Ruffneck™ explosion-proof electric air heater, built for severe duty applications that can lead to accelerated wear of electrical components and damage to the heater core. The FX5-SD is specifically designed for severe duty applications including locations with:

- fluctuating power quality
- temporary power generation
- high vibration
- dirty or corrosive atmospheres or
- extended maintenance intervals

Only the Ruffneck™ FX5-SD incorporates a dedicated shunt trip circuit breaker which operates independent of the control circuit. It is triggered by a redundant heater core high temperature limit enabling primary interruption of line power to safely protect the heater core. Additional standard features include a definite purpose high capacity contactor, explosion-proof Arctic Duty motor and heavy gauge wiring to make the FX5-SD the safest and most robust explosion-proof unit heater available.

FX5-SD heaters are cUL_{US} approved for use in hazardous locations.

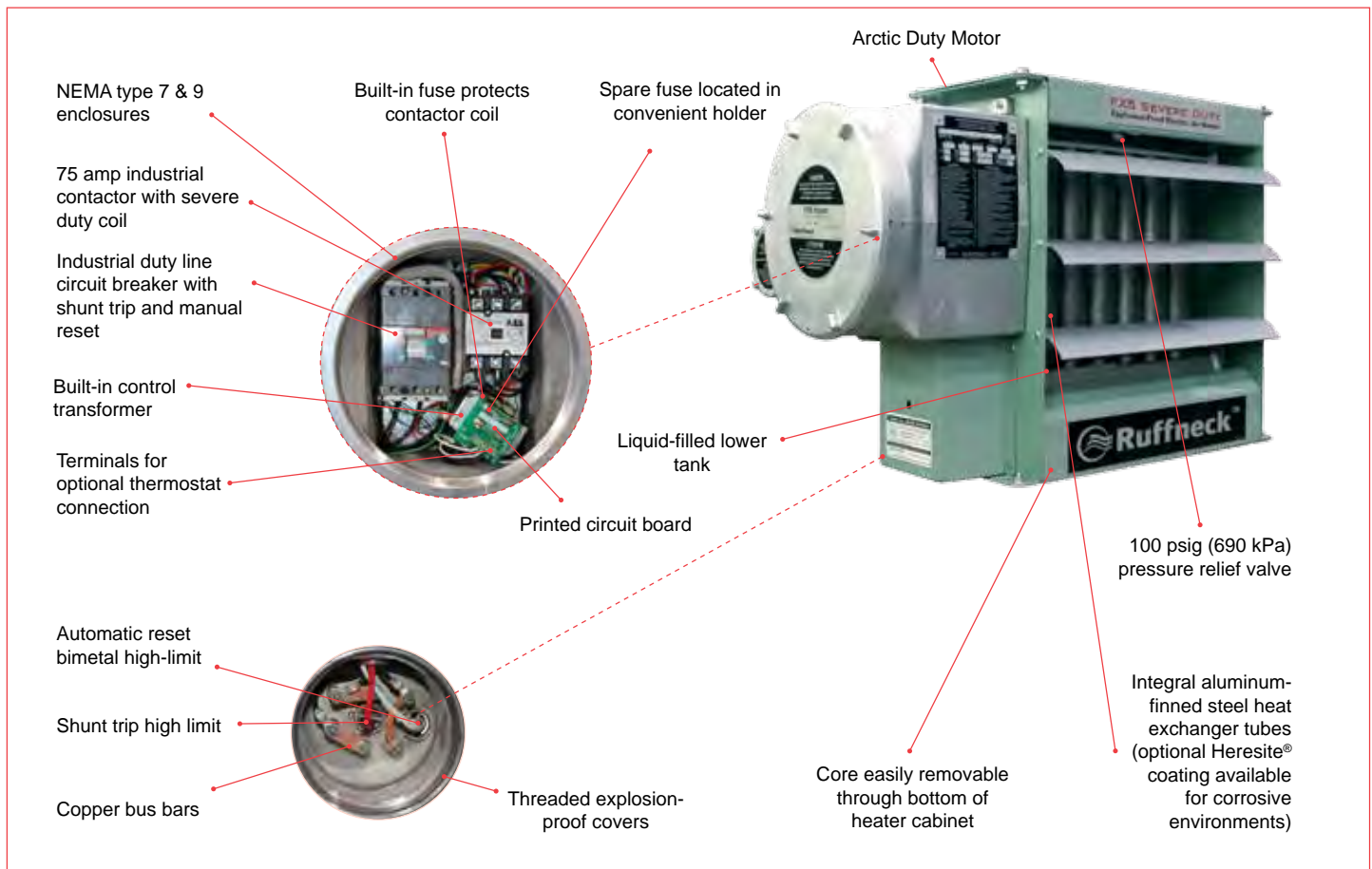

Heresite® is a registered trademark of Heresite® Protective Coatings Inc.

FX5-SD

**Performance Data for 60 Hertz FX5-SD
UL_c Temperature Code T3B 165°C (329°F)**

NOMINAL WATTAGE (kW)	MODEL	VOLTAGE	PHASE	TOTAL CURRENT (A)	OPTIONAL BUILT-IN DISCONNECT SWITCH	AIR TEMPERATURE RISE		Btu/hr
						°F	°C	
3	FX5-SD-208160-030	208	1	14.4	DS5	19.0	10.5	10,250
	FX5-SD-208360-030	208	3	8.3				
	FX5-SD-240160-030	240	1	12.5				
	FX5-SD-240360-030	240	3	7.2				
	FX5-SD-480160-030 ^o	480	1	6.3				
	FX5-SD-480360-030	480	3	3.6				
FX5-SD-600360-030	600	3	2.9					
5	FX5-SD-208160-050	208	1	24.0	DS5	31.6	17.6	17,050
	FX5-SD-208360-050	208	3	13.9				
	FX5-SD-240160-050	240	1	20.8				
	FX5-SD-240360-050	240	3	12.0				
	FX5-SD-480160-050 ^o	480	1	10.4				
	FX5-SD-480360-050	480	3	6.0				
FX5-SD-600360-050	600	3	4.8					
7.5	FX5-SD-208160-075	208	1	36.1	DS5	27.9	15.5	25,600
	FX5-SD-208360-075	208	3	20.8				
	FX5-SD-240160-075	240	1	31.3				
	FX5-SD-240360-075	240	3	18.0				
	FX5-SD-480160-075 ^o	480	1	15.6				
	FX5-SD-480360-075	480	3	9.0				
FX5-SD-600360-075	600	3	7.2					
10	FX5-SD-208160-100*	208	1	48.1	Not Available DS5	37.2	20.6	34,100
	FX5-SD-208360-100	208	3	27.8				
	FX5-SD-240160-100	240	1	41.7				
	FX5-SD-240360-100	240	3	24.1				
	FX5-SD-480160-100 ^o	480	1	20.8				
	FX5-SD-480360-100	480	3	12.0				
FX5-SD-600360-100	600	3	9.6	DS5				
15	FX5-SD-208360-150	208	3	41.6	Not Available DS5	27.1	15.1	51,200
	FX5-SD-240160-150*	240	1	62.5				
	FX5-SD-240360-150	240	3	36.1				
	FX5-SD-480160-150 ^o	480	1	31.3				
	FX5-SD-480360-150	480	3	18.0				
	FX5-SD-600360-150	600	3	14.4				
20	FX5-SD-480160-200 ^o	480	1	41.7	DS5	36.1	20.1	68,250
	FX5-SD-480360-200	480	3	24.1				
	FX5-SD-600360-200	600	3	19.2				
25	FX5-SD-480360-250	480	3	30.1	DS5	22.0	12.2	85,300
	FX5-SD-600360-250	600	3	24.1				
30	FX5-SD-480360-300	480	3	36.1	DS5	26.4	14.6	102,350
	FX5-SD-600360-300	600	3	28.9				
35	FX5-SD-480360-350	480	3	42.1	DS5	30.7	17.1	119,450
	FX5-SD-600360-350	600	3	33.7				

Consult Terms & Conditions of Sale (or FX5-SD Owner's Manual) for warranty information.

Note: (*) Exceeds the 48 amp circuit limit of NEC 424-22

(^o) 480V 1 Phase units are certified Class I, Div. 1, Group D and Class II, Div.1, Groups F and G.

1. Minimum conductor size for 86°F (30°C) ambient. Derate conductor for ambient temperature. Use minimum 90°C (194°F) insulation.
2. Heater is functioning normally if at rated voltage the amp draw is within 10% of the value in this table.
3. Operation at lower voltage will result in reduced heat output and amp draw.
4. Add "T" to model number when adding a built-in thermostat.
5. Add "D" to model number when adding a built-in disconnect switch.
6. Add "C" to model number for units with Heresite[®] coating.
7. Add "A" to model number for units with stainless-steel cabinet.
8. Add "B" to model number for certified use of low ambient of -50°C (-58°F).
9. Add "H" to model number for units with high temperature "OFF" (de-energized ambient temperatures).

See page 16 for model coding.

See page 14 for installation conditions.

FX5-SD

Performance Data for 50 Hertz FX5-SD

NOMINAL WATTAGE (kW)	MODEL	VOLTAGE	PHASE	TOTAL CURRENT (A)	OPTIONAL BUILT-IN DISCONNECT SWITCH	AIR TEMPERATURE RISE		Btu/hr
						°F	°C	
2.5	FX5-SD-220150-025	220	1	11.4	DS5	19.7	11.0	8,550
4.2	FX5-SD-220150-042	220	1	19.1	DS5	33.2	18.4	14,350
6.3	FX5-SD-220150-063	220	1	28.6	DS5	28.5	15.7	21,500
8.4	FX5-SD-220150-084	220	1	38.2	DS5	37.8	21.1	28,700
12.6	FX5-SD-220150-126*	220	1	57.3	Not Available	27.5	15.2	43,000
2.8	FX5-SD-230150-028	230	1	12.20	DS5	22.1	12.3	9,550
4.6	FX5-SD-230150-046	230	1	20.0	DS5	36.4	20.2	16,000
6.9	FX5-SD-230150-069	230	1	30.0	DS5	31.1	17.2	23,550
13.8	FX5-SD-230150-138*	230	1	59.9	Not Available	30.1	16.6	47,100
2.5	FX5-SD-380350-025	380	3	3.8	DS5	19.7	11.0	8,550
4.2	FX5-SD-380350-042	380	3	6.4	DS5	33.2	18.4	14,350
6.3	FX5-SD-380350-063	380	3	9.6	DS5	28.5	15.7	21,500
8.4	FX5-SD-380350-084	380	3	12.8	DS5	37.8	21.1	28,700
12.5	FX5-SD-380350-125	380	3	19.0	DS5	27.2	15.1	42,700
20.9	FX5-SD-380350-209	380	3	31.8	DS5	22.0	12.1	71,350
2.8	FX5-SD-400350-028	400	3	4.0	DS5	22.1	12.3	9,550
4.6	FX5-SD-400350-046	400	3	6.6	DS5	36.4	20.2	15,700
6.9	FX5-SD-400350-069	400	3	10.0	DS5	31.1	17.2	23,550
9.3	FX5-SD-400350-093	400	3	13.4	DS5	42.0	23.2	31,750
13.9	FX5-SD-400350-139	400	3	20.1	DS5	30.2	16.7	74,450
18.5	FX5-SD-400350-185	400	3	26.7	DS5	40.2	22.3	63,150
23.1	FX5-SD-400350-231	400	3	33.3	DS5	24.2	13.5	78,850
3.7	FX5-SD-415350-037	415	3	5.1	DS5	29.3	16.3	12,650
7.5	FX5-SD-415350-075	415	3	10.4	DS5	33.8	18.7	25,600
14.9	FX5-SD-415350-149	415	3	20.7	DS5	32.5	18.1	50,850
22.4	FX5-SD-415350-224	415	3	31.2	DS5	23.5	13.1	76,450
4.2	FX5-SD-440350-042	440	3	5.5	DS5	33.2	18.4	14,350
8.4	FX5-SD-440350-084	440	3	11.0	DS5	37.8	21.1	28,700
16.8	FX5-SD-440350-168	440	3	27.5	DS5	36.5	20.3	57,350
20.9	FX5-SD-440350-209	440	3	27.5	DS5	22.1	12.2	71,350

Notes:

1. Minimum conductor size for 86°F (30°C) ambient. Derate conductor for ambient temperature use minimum 194°F (90°C) insulation.
2. Heater is functioning normally if at rated voltage the amp draw is within 10% of the value in this table.
3. Operation at lower voltage will result in reduced heat output and amp draw.
4. Add "T" to model number when adding a built-in thermostat.
5. Add "D" to model number when adding a built-in disconnect switch.
6. Add "C" to model number for units with Heresite® coating.
7. Add "A" to model number for units with stainless-steel cabinet.
8. Add "B" to model number for certified use of low ambient of -50°C (-58°F).
9. Add "H" to model number for units with high temperature "OFF" (de-energized ambient temperatures).

Installation Conditions:

1. The FX5-SD Series Electric Air Heaters are for dry indoor use only. Do not immerse in water. Do not store or use in areas exposed to rain or snow.
 2. The FX5-SD heaters are to be used only in atmospheres having an ignition temperature higher than 329°F (165°C).
 3. Altitude restrictions apply - see specifications on next page.
 4. Heaters should be connected to a fixed power supply and must be permanently mounted in a level, upright position during operation.
 5. Read and be aware of the terms of our Warranty located in the owner's manual.
 6. Refer to Owner's Manual.
- Note: (*) Exceeds the 48 amp circuit limit of NEC 424-22.**

Specifications for 60 Hertz FX5-SD

60 HERTZ		FX5-SD									
		NOMINAL kW		3	5	7.5	10	15	20	25	30
Maximum Altitude	(ft)	12,000	8,000	10,000	7,000	10,000	7,000	10,000	7,000	6,000	
	(m)	3,658	2,438	3,048	2,134	3,048	2,134	3,048	2,134	1,829	
Air Delivery @ 70°F	(CFM)	500		850		1,750			3,600		
	@ 21°C (m³/hr)	850		1,444		2,973			6,116		
Horizontal Throw	(ft)	15		30		40			70		
	(m)	4.6		9.1		12.2			21.3		
Maximum Mounting Height (to underside)	(ft)	7		10		10			20		
	(m)	2.1		3.0		3.0			6.1		
Motor Power*	(HP)	1/2				1/2			1/2		
	(kW)	0.373				0.373			0.373		
Motor Speed	(RPM)	1,725				1,725			1,725		
Fan Diameter	(in)	12				16			20		
	(mm)	305				406			508		
Net Weight		without DS5		with DS5		without DS5		with DS5	without DS5		with DS5
	(lbs)	142		154		170		182	203		215
	(kg)	65		70		77		82	92		98
Shipping Weight	(lbs)	194		206		218		230	252		264
	(kg)	88		93.4		98.9		104.3	114.3		119.7

See page 17 for general specifications common to all FX5-SD models.

Weights are an approximate maximum.

*Manufacturer reserves the right to replace motors with suitable alternates.

Specifications for 50 Hertz FX5-SD

50 HERTZ		FX5-SD									
		NOMINAL kW		2.5	3.7 & 4.6	6.3 & 7.5	8.4	12.5 & 12.6	14.9 & 16.7	20.9	22.4
Maximum Altitude	(ft)	12,000	8,000	10,000	7,000	10,000	7,000	10,000	7,000		
	(m)	3,658	2,438	3,048	2,134	3,048	2,134	3,048	2,134		
Air Delivery @ 71°F	(CFM)	400		700		1,450			3,000		
	@ 21°C (m³/hr)	679		1,189		2,463			5,096		
Horizontal Throw	(ft)	13		25		35			60		
	(m)	4.0		7.6		10.7			18.2		
Maximum Mounting Height (to underside)	(ft)	7		10		10			20		
	(m)	2.1		3.0		3.0			6.1		
Motor Speed	(RPM)	1,437				1,437			1,437		
Motor Power*	(HP)	1/2				1/2			1/2		
	(kW)	0.373				0.373			0.373		
Fan Diameter	(in)	12				16			20		
	(mm)	305				406			508		
Net Weight		without DS5		with DS5		without DS5		with DS5	without DS5		with DS5
	(lbs)	140		152		168		180	201		213
	(kg)	142		154		170		182	203		215
Shipping Weight	(lbs)	65		70		77		82	92		98
	(kg)	88		93.4		98.9		104.3	114.3		119.7

See page 17 for general specifications common to all FX5-SD models.

Weights are an approximate maximum.

* Manufacturer reserves the right to replace motors with suitable alternates.

FX5-SD

DIM.	kW	2.5-10	12.5-20	20.9-35	DIM. TOL. ±
		A	in. 7	7	
	mm	178	178	178	3
B	in.	18-3/16	22-5/16	26-1/4	1/8
	mm	462	566	667	3
C	in.	27	31	35	3/16
	mm	686	787	889	4
D	in.	19	23	27	1/8
	mm	484	586	688	3
E	in.	19-7/16	23-7/16	27-7/16	3/8
	mm	492	596	697	10
F	in.	17-1/2	19-1/2	21-13/16	5/16
	mm	444	495	554	8
G	in.	24-5/8	28-5/8	32-5/8	3/16
	mm	625	727	828	4

DIMENSIONAL TOLERANCES $\pm 1/8"$ [$\pm 3\text{mm}$]
UNLESS OTHERWISE SPECIFIED.

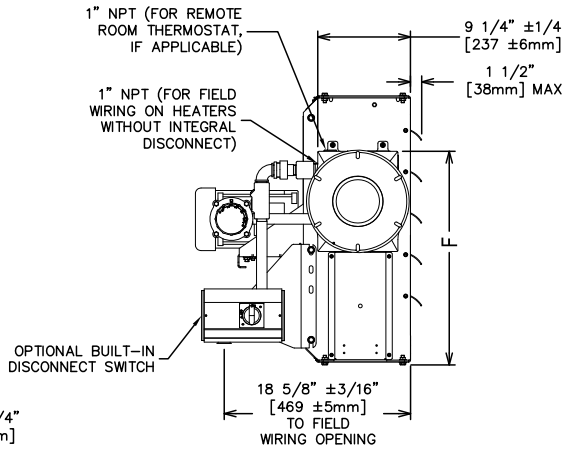
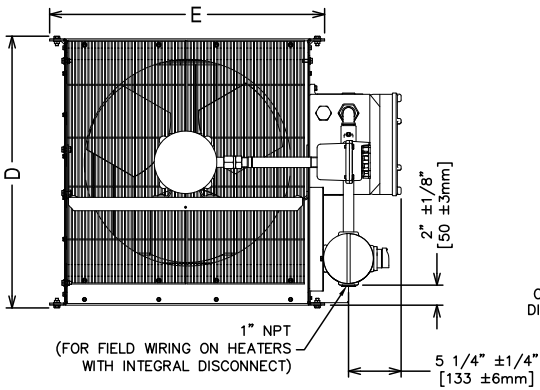
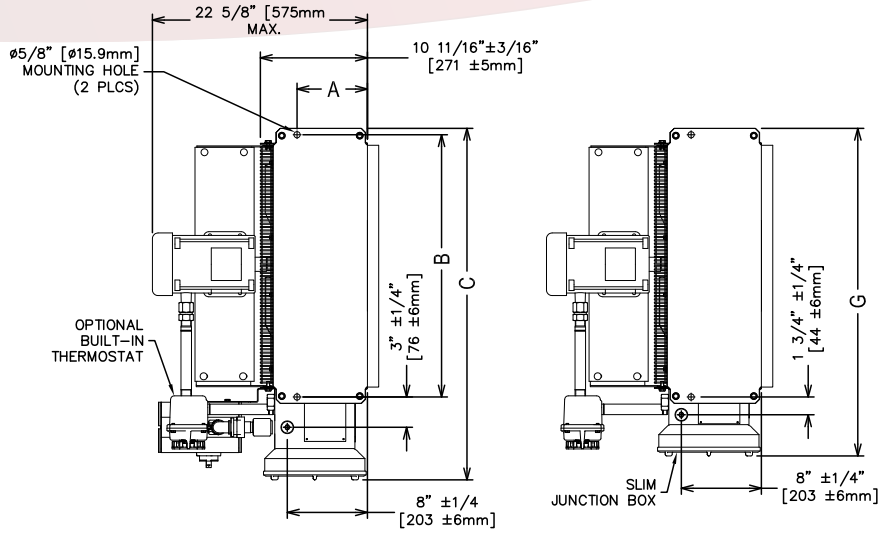

Model Coding

FX 5 - SD - 480 3 60 - 350 - W T, D, C, A, U

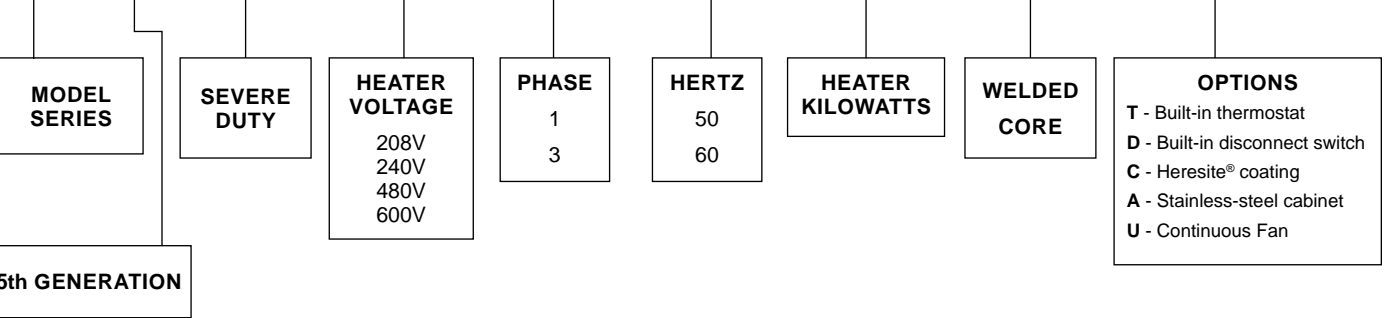

Reminder: This nomenclature illustration is intended primarily to explain how a product part number is defined. Not all voltage and/or wattage combinations are available - please consult the Performance Data chart(s) for product availability.

FX5-SD

FX5-SD General Specifications

Approvals	
Hazardous Locations Classifications	Class I, Divisions 1 & 2, Groups C & D Class II, Divisions 1, Groups E, F & G Class II, Divisions 2, Groups F & G Class I, Zones 1 & 2, Group IIA & IIB Temperature Code T3B 329°F (165°C)
Motor Type	Explosion-proof. Thermally protected TEFC Arctic Duty. Permanently lubricated ball bearings. Add "B" to model coding for certified use at low temperature -50°C (-58°F).
Fan	Aluminum blade. Steel spider and hub with 5/8" (15 mm) bore
Fan Guard	Split design with close wire spacing. 1/4" (6.3 mm) diameter probe will not enter
Mounting Holes	Four 5/8" (15.9 mm) diameter holes at the top of heater
Heating Elements	Long-life metal-sheathed elements
Temperature High-Limit	Primary automatic reset type, snap-action bimetal, open on temperature rise. Rated 100,000 cycles at 15 amp, handles 0.128 amps/Secondary automatic reset type, snap-action bimetal, close on temperature rise. Rated 100,000 cycles at 15 amp, handles 0.128 amps
Control Circuit	120V, 0.128 amps, 15VA. (Grounded)
Optional Built-in Thermostat	Explosion-proof 2°C to 28°C (36°F to 82°F)
Control Transformer	Multiple voltage primary, 120V secondary, 50VA
Circuit Protection	Industrial duty line circuit breaker with shunt trip
Contactors	Standard 75 amp, rated for 500,000 mechanical operations, 120V, 15 VA coil (separately fused - protected)
Cabinet Material	12-gauge (0.315" / 2.60 mm) epoxy powder coated steel. Optional Heresite® coating available for corrosive atmospheres with an optional stainless-steel casing
Core	HD Core (Propylene Glycol) charge under vacuum
Heat Transfer Fluid	Propylene Glycol and water
Conduit Material	Heavy wall, 0.122" (3.1 mm), steel
Overpressure Protection	Preset 100 psig (690 kPa) pressure relief valve, aluminum body, no serviceable parts
Operational Temperature Range	-4°F to 104°F (-20°C to 40°C); for "B" units -58°F to 104°F (-50°C to 40°C)
Junction Box (H x W x D)	10.25" (230 mm) x 8.00" (180 mm) x 9.12" (205 mm)
Field Connection	Two 1" NPT
Weight (for 15 kW unit)	170 lbs (77.27 kgs)
Weight with disconnect (for 15 kW unit)	182 lbs (82.73 kgs)
Optional Built-in Disconnect Switch	DS5 uses <i>x-Max</i> ® construction

FX5-SD

FE2 Explosion-Proof Electric Air Heaters



The heater core assembly is contained in a sturdy, epoxy-coated, 12-gauge steel cabinet which also carries the motor and fan assembly. Adjustable louvers allow directional control of the airflow. A narrow gap, two-piece fan guard is provided to shield all moving parts. All fasteners are zinc plated for corrosion protection.

All aspects and details of the FE2 are subjected to exhaustive technical analysis and testing during design and development, and are manufactured under a registered quality assurance program. As a result, they have consistently proven their safety and reliability.



FE2 heaters are CE Marked & ATEX Approved to Directive 94/9/EC for use in hazardous locations. They are designed for dry indoor industrial applications such as oil refineries, petrochemical plants, pulp and paper mills, hazardous waste storage facilities, wastewater treatment plants, etc., where specific explosive gases or dusts maybe present.

All FE2 heaters utilize the VacuCore® liquid-to-air heat exchanger. The induced vacuum within the sealed core provides greater efficiency, even distribution of heat across the face of the exchanger, and a faster warm-up. When necessary, the entire core can be safely and easily replaced with a new exchanger or core.



Model Coding

FE2 - 220 1 50 - 025 - W - T

Model Series | Heater Voltage | Phase | Hertz | Heater Kilowatts | Welded Core

2nd Generation | | | | |

- T – Built-in thermostat
- D – Built-in disconnect switch
- C – Heresite® coating
- A – Stainless steel cabinet
- U – Continuous fan
- B – Low ambient option -50°F (-50°C)
- M25 – M25 adapter field entry

FE2

Performance Data for 50 Hertz FE2

CE DEMKO 10 ATEX 0910365X Ex II 2 G, Ex d IIB T3 Gb EAC 1 Ex d IIB T3 Gb X

	MODEL	NOMINAL WATTAGE (kW)	BTU/hr	PHASE	TOTAL CURRENT (A)	AIR TEMPERATURE RISE	
						°C	°F
220V	FE2-220150-025	2.5	8,550	1	11.4	10.6	19.2
	FE2-220150-042	4.2	14,350	1	19.1	17.9	32.2
	FE2-220150-063	6.3	21,500	1	28.6	15.8	28.4
	FE2-220150-084	8.4	28,700	1	38.2	21.0	37.8
	FE2-220150-126	12.6	43,050	1	57.3	15.3	27.6
230V	FE2-230150-028	2.8	9,550	1	12.0	12.0	21.6
	FE2-230150-046	4.6	15,700	1	20.0	19.8	35.6
	FE2-230150-069	6.9	23,550	1	29.9	17.4	31.4
	FE2-230150-092	9.2	31,400	1	39.9	23.2	41.8
	FE2-230150-138	13.8	47,150	1	59.9	17.0	30.5
240V	FE2-240150-030	3.0	10,250	1	12.4	12.8	23.1
	FE2-240150-050	5.0	17,100	1	20.8	21.4	38.5
	FE2-240150-075	7.5	25,600	1	31.2	18.8	33.9
	FE2-240150-100	10.0	34,150	1	41.7	25.1	45.2
	FE2-240150-150	15.0	51,250	1	62.5	18.3	32.9
380V	FE2-380350-025	2.5	8,550	3	3.8	11.2	20.1
	FE2-380350-042	4.2	14,350	3	6.4	18.7	33.7
	FE2-380350-063	6.3	21,500	3	9.6	16.5	29.7
	FE2-380350-084	8.4	28,700	3	12.8	22.0	39.7
	FE2-380350-125	12.5	42,700	3	19.0	15.9	28.7
	FE2-380350-167	16.7	57,050	3	25.4	21.3	38.3
	FE2-380350-209	20.9	71,400	3	31.8	12.9	23.3
400V	FE2-400350-028	2.8	9,550	3	4.1	12.3	22.1
	FE2-400350-046	4.6	15,700	3	6.6	20.2	36.3
	FE2-400350-069	6.9	23,550	3	10.0	17.8	32.1
	FE2-400350-093	9.3	31,750	3	13.4	24.0	43.2
	FE2-400350-139	13.9	47,450	3	20.1	17.4	31.4
	FE2-400350-185	18.5	63,200	3	26.7	23.2	41.8
	FE2-400350-231	23.1	78,900	3	33.3	14.1	25.4
415V	FE2-415350-037	3.7	12,650	3	5.1	16.2	29.1
	FE2-415350-075	7.5	25,600	3	10.4	19.2	34.6
	FE2-415350-149	14.9	50,900	3	20.7	18.6	33.4
	FE2-415350-187*	18.7	63,850	3	26.0	23.3	41.9
	FE2-415350-224	22.4	76,500	3	31.2	13.6	24.4
	FE2-415350-262*	26.2	89,500	3	36.5	15.9	28.6
440V	FE2-440350-042	4.2	14,350	3	5.5	19.3	34.8
	FE2-440350-084	8.4	28,700	3	11.0	21.8	39.2
	FE2-440350-168	16.8	57,400	3	22.0	21.0	37.9
	FE2-440350-210	21.0	71,700	3	27.6	12.7	22.9
	FE2-440350-252*	25.2	86,050	3	33.1	15.2	27.4
	FE2-440350-294*	29.4	100,400	3	38.6	17.8	32.0

*Available on "B" models only

FE2

Specifications for 50 Hertz FE2

		Nominal kW							
		2.5 – 3.0	3.7 – 5.0	6.3 – 7.5	8.4 – 10.0	12.5 – 13.9	14.9 – 20	20.9 – 21	22.4 – 29.4
Altitude (max.)	ft	12,000	8,000	10,000	7,000	10,000	7,000	10,000	7,000
	m	3,658	2,438	3,048	2,134	3,048	2,134	3,048	2,134
Air Flow (min.)	@ 70°F (CFM)	387		678		1,404		2,905	
	@ 21°C (m³/hr)	658		1,152		2,385		4,936	
Horizontal Air Throw	ft	13		25		35		60	
	m	4.0		7.6		10.7		18.2	
Maximum Mounting Height (to underside)	ft	7		10		10		20	
	m	2.1		3.0		3.0		6.1	
Motor Speed (min.)	RPM	1360							
Fan Diameter	in	12			16		20		
	mm	305			406		508		
Net Weight	without	lbs	174			202		235	
		kg	79			92		107	
	with DS5	lbs	186			214		247	
		kg	84			97		112	
Shipping Weight	without	lbs	228			252		286	
		kg	103			114		130	
	with DS5	lbs	240			264		298	
		kg	109			120		135	

Weights are an approximate maximum.



Notes:

1. Minimum conductor size for 30°C (86°F) ambient. Derate conductor for ambient temperature. Use minimum 90°C (194°F) insulation.
2. Heater is functioning normally if at rated voltage the amp draw is within 10% of the value in this table.
3. Operation at lower voltage will result in reduced heat output and amp draw.
4. Add "T" to model number when adding a built-in thermostat.
5. Add "D" to model number for units with disconnect switch option.
6. Add "A" to model number for units with stainless-steel cabinet.
7. Add "C" to model number for Heresite® coated panels and core.
8. Add "U" to model number for units with a continuous fan.
9. Add "B" for minimum ambient temperature of -50 °C. Contact factory for available models.
10. Add "M25" for M25 adapter field entry.

Installation Conditions:

1. The FE2 Series Electric Air Heaters are for dry indoor use only. Do not immerse in water. Do not store or use in areas exposed to rain or snow.
2. The FE2 heaters are to be used only in atmospheres having an ignition temperature higher than Temperature Code T3 200°C (329°F) for Class I & II.
3. Altitude restrictions apply - see specifications above.
4. Heaters should be connected to a fixed power supply and must be permanently mounted in a level, upright position during operation.
5. Read and be aware of the terms of our Warranty located in the owner's manual.
6. Refer to Owner's Manual.

Performance Data for 60 Hertz FE2

CEMCO 10 ATEX 0910365X  II 2 G, Ex d IIB T3 Gb  1 Ex d IIB T3 Gb X

	MODEL	NOMINAL WATTAGE (kW)	BTU/hr	PHASE	TOTAL CURRENT (A)	AIR TEMPERATURE RISE	
						°C	°F
220 VOLT	FE2-220160-025	2.5	8,550	1	11.4	8.8	15.8
	FE2-220160-042	4.2	14,350	1	19.1	14.8	26.6
	FE2-220160-063	6.3	21,500	1	28.6	13.0	23.4
	FE2-220160-084	8.4	28,700	1	38.2	17.4	31.3
	FE2-220160-126	12.6	43,050	1	57.3	12.7	22.8
230 VOLT	FE2-230160-028	2.8	9,550	1	12.0	9.8	17.7
	FE2-230160-046	4.6	15,700	1	20.0	16.2	29.1
	FE2-230160-069	6.9	23,550	1	29.9	14.3	25.7
	FE2-230160-092	9.2	31,400	1	39.9	19.0	34.2
	FE2-230160-138	13.8	47,150	1	59.9	13.9	24.9
240 VOLT	FE2-240160-030	3.0	10,250	1	12.4	10.5	19.0
	FE2-240160-050	5.0	17,100	1	20.8	17.6	31.7
	FE2-240160-075	7.5	25,600	1	31.2	15.5	27.9
	FE2-240160-100	10.0	34,150	1	41.7	20.7	37.2
	FE2-240160-150	15.0	51,250	1	62.5	15.1	27.1
440 VOLT	FE2-440360-042	4.2	14,350	3	5.5	14.8	26.6
	FE2-440360-084	8.4	28,700	3	11.0	17.4	31.3
	FE2-440360-168	16.8	57,400	3	22.0	16.9	30.4
	FE2-440360-210	21.0	71,700	3	27.6	10.2	18.4
	FE2-440360-252*	25.2	86,050	3	33.1	13.4	24.1
	FE2-440360-294*	29.4	100,400	3	38.6	15.6	28.1
480 VOLT	FE2-480360-030	3.0	10,250	3	3.6	10.5	19.0
	FE2-480360-050	5.0	17,100	3	6.0	17.6	31.7
	FE2-480360-075	7.5	25,600	3	9.0	15.5	27.9
	FE2-480360-100	10.0	34,150	3	12.0	20.7	37.2
	FE2-480360-150	15.0	51,250	3	18.0	15.1	27.1
	FE2-480360-200	20.0	68,300	3	24.1	20.1	36.1
	FE2-480360-250*	25.0	85,400	3	30.1	12.2	22.9
	FE2-480360-300*	30.0	102,450	3	36.1	14.6	27.5
FE2-480360-350*	35.0	119,550	3	42.1	17.1	32.0	

*Available on "B" models only.

FE2

Specifications for 60 Hertz FE2

		Nominal kW							
		2.5 – 3.0	3.7 – 5.0	6.3 – 7.5	8.4 – 10	12.5 – 13.9	14.9 – 20	20.9 – 21	22.4 – 35.0
Altitude (max.)	ft	12,000	8,000	10,000	7,000	10,000	7,000	10,000	7,000
	m	3,658	2,438	3,048	2,134	3,048	2,134	3,048	2,134
Air Flow (min.)	@ 70°F (CFM)	394		670		1,380		2,838	
	@ 21°C (m³/hr)	669		1138		2,345		4,822	
Horizontal Air Throw	ft	15		30		40		70	
	m	4.6		9.1		12.2		21.3	
Maximum Mounting Height (to underside)	ft	7		10		10		20	
	m	2.1		3.0		3.0		6.1	
Motor Speed (min.)	RPM	1360							
Fan Diameter	in	12			16		20		
	mm	305			406		508		
Net Weight	without	lbs	174		202		235		
	DS5	kg	79		92		107		
	with	lbs	186		214		247		
	DS5	kg	84		97		112		
Shipping Weight	without	lbs	228		252		286		
	DS5	kg	103		114		130		
	with	lbs	240		264		298		
	DS5	kg	109		120		135		

Weights are an approximate maximum.



Notes:

1. Minimum conductor size for 30°C (86°F) ambient. Derate conductor for ambient temperature. Use minimum 90°C (194°F) insulation.
2. Heater is functioning normally if at rated voltage the amp draw is within 10% of the value in this table.
3. Operation at lower voltage will result in reduced heat output and amp draw.
4. Add "T" to model number when adding a built-in thermostat.
5. Add "D" to model number for units with disconnect switch option.
6. Add "A" to model number for units with stainless-steel cabinet.
7. Add "C" to model number for Heresite® coated panels and core.
8. Add "U" to model number for units with a continuous fan.
9. Add "B" for minimum ambient temperature of -50°C. Contact factory for available models.
10. Add "M25" for M25 adapter field entry.

Installation Conditions:

1. The FE2 Series Electric Air Heaters are for dry indoor use only. Do not immerse in water. Do not store or use in areas exposed to rain or snow.
2. The FE2 heaters are to be used only in atmospheres having an ignition temperature higher than Temperature Code T3 200°C (329°F) for Class I & II.
3. Altitude restrictions apply - see specifications above.
4. Heaters should be connected to a fixed power supply and must be permanently mounted in a level, upright position during operation.
5. Read and be aware of the terms of our Warranty located in the owner's manual.
6. Refer to Owner's Manual.

FE2 General Specifications

Approvals	ATEX Approved (Directive 94/9/EC)
Hazardous Location Classifications	CE DEMKO 10 ATEX 0910365X  II 2 G, Ex d IIB T3  1 Ex d IIB T3 Gb X
Enclosures	NEMA Type 7 & 9. For dry, indoor use only. Do not immerse in water. Do not store or use in areas exposed to rain or snow
Motor Type	Explosion-proof. Thermally protected. Permanently lubricated ball bearings 1425 RPM @ 50 Hz or 1725 RPM @ 60 Hz
Fan	Aluminum blade. Steel spider and hub with 19 mm (3/4") bore
Fan Guard	Split design with close wire spacing. Meets latest EN standards
Mounting Holes	Four 16 mm (5/8") diameter holes at top of heater
Heating Elements	Three long-life, low watt-density, high grade metal-sheathed elements
Temperature High-Limit	Automatic reset type, snap-action bimetal, open on temperature rise. Rated 100,000 cycles at 10 amps, handles 0.130 amps
Control Circuit	115V, 0.130 amps, 15 VA. (Grounded)
Optional Built-in Thermostat	Explosion-proof. 2°C to 28°C (36°F to 82°F)
Control Transformer	Multi-tap primary, 115V secondary, 50 VA
Contactors	75 amp. Rated for 1,000,000 mechanical operations. 120V, 15 VA coil (separately fused - protected)
Heat Transfer Fluid	Long life formulated Propylene Glycol and water, freeze protected to -45°C (-49°F)
Cabinet Material	12-gauge (0.075" / 2 mm) steel. Epoxy coated with five-stage pretreatment, including iron phosphate
Core	Steel with integral aluminum fins, vacuum charged and hermetically sealed
Conduit Material	Heavy wall, 0.122" (3 mm) steel-plated
Overpressure Protection	Preset 690 kPa (100 psig) seep pressure relief valve, aluminum body, not field serviceable
Operational Temperature Limitations	-20°C to 40°C (-4°F to 104°F) and -50°C to 40°C for "B" units

CX1 ProVector® Explosion-Proof Heaters

For hazardous locations heating, rely on the Ruffneck™ CX1 ProVector® for the most dependable, trouble-free service available. CCI Thermal Technologies Inc. manufactures explosion-proof air heaters to satisfy the demanding requirements of the oil and gas well drilling industry. The harsh operating conditions of this application require the utmost in heater reliability.

Feature

- available in 1-phase or 3-phase
- available up to an industry leading 10 kW
- sloped-top cabinet
- no exposed copper or brass
- high-velocity airflow
- 14-gauge steel cabinet, available with stainless-steel construction
- one of the shortest cabinet lengths available
- optional built-in thermostat
- Incoloy® 840 heating elements
- radial-embossed aluminum plate fins
- galvanized steel mounting brackets
- approvals - Groups A, B, C, D; IIA, IIB & IIC; available IP55 moisture ingress protection

The unique design features and rugged, quality construction details that have made Ruffneck™ heaters the choice of the oil and gas industry are also appreciated by other heavy-duty industries throughout the world. The CX1 ProVector® explosion-proof heater offers the following outstanding features and benefits:

Benefit

- prevents objects from being set on top which restrict airflow
- corrosion resistant, suitable for H₂S environments
- heats up area faster with better heat distribution
- rugged reliability and unsurpassed corrosion resistance available with stainless-steel construction
- smaller profile utilizes less wall and floor space
- reduced field installation costs
- longer life expectancy
- reduced fin warping for better heat transfer capabilities
- quick installation
- industry first approvals for built-in thermostat with Groups A, B, C, D; IIA, IIB, IIC ratings



Sloped top cabinet prevents objects from being set on top which could restrict airflow

Openings optimized for maximum safety and high airflow velocity

Epoxy-coated 14-gauge steel front and side cabinet panels
SS 304 available

Finned tube assembly can be easily removed

Radial-embossed aluminum plate fins

14-gauge galvanized steel rear cabinet panel
SS 304 available

Large, heavy-duty aluminum data plate for legibility

Upward facing bolted explosion-proof cover

Aluminum enclosure

Incoloy® 840 heating elements contained in aluminum tube assembly

Optional built-in room thermostat with low (1) to high (10) settings. Available with Defender® or x-Max® housings (not shown)

CX1 ProVector®

CX1 ProVector® General Specifications

Approvals	
Hazardous Location Classifications	
Without Built-in Thermostat	FX4 Housing - Class I, Div. 1 & 2, Groups C & D. Defender® housing Class I, Div. 1 & 2, Groups B, C, & D; Zones 1 & 2, Groups IIA, IIB + H ₂ x-Max ® housing Class I, Div. 1 & 2, Groups A, B, C, & D; Zones 1 & 2, Groups IIA, IIB, & IIC ²
With Built-in Thermostat	XCT Defender® thermostat: Class I, Div. 1 & 2, Groups C & D; Zones 1 & 2, Groups IIA & IIB XT thermostat: Class I, Div. 1 & 2, Groups A, B, C, & D; Zones 1 & 2, Groups IIA, IIB, & IIC
Enclosure	Defender® housing is cast aluminum with bolt on cover. Groups IIB x-Max ® housing is extruded aluminum with two screwed on covers. The x-Max ® housing offers IP55 moisture ingress protection, Groups IIC. FX4 housing is cast aluminum with screwed on cover, Groups IIB. For dry indoor use only. Do not immerse in water. Do not store in areas exposed to rain or snow.
Mounting Brackets	Two 14-gauge (0.075" / 1.9 mm) galvanized steel brackets for standard cabinet. Stainless-steel brackets provided with optional stainless-steel cabinet
Heating Elements	Two Incoloy® 840 sheathed elements
Temperature Code Rating	Temperature Code T2A - 536°F (280°C) or T3 - 392°F (200°C)
Temperature Limitations	Operational: -49°F to 104°F (-45°C to 40°C) Storage: -49°F to 176°F (-45°C to 80°C). Optional up to 300°F (149°C) available
Cabinet Material	14-gauge (0.075" / 1.90mm) epoxy coated steel with galvanized rear panel. Optional - 14-gauge 304 stainless-steel cabinet and mounting hardware available

Nominal kW		0.75 - 2.69 & 3.6 (T2A)	3.01 - 3.59, 3.6 (T3) & 4.8	4.76, 5.28 - 7.6	3.13, 3.47, 3.74, 5.0, 6.26, 6.94, 7.47, 10.0
Cabinet Length	in (mm)	31.3 (796)	49.4 (1256)	59.5 (1511)	71.8 (1823)
Net Weight	(lbs)	55.3	80.7	92.8	117.0
	(kg)	25.1	36.6	42.1	53.2
Shipping Weight	(lbs)	65	95	105	142.0
	(kg)	30	44	48	65.5

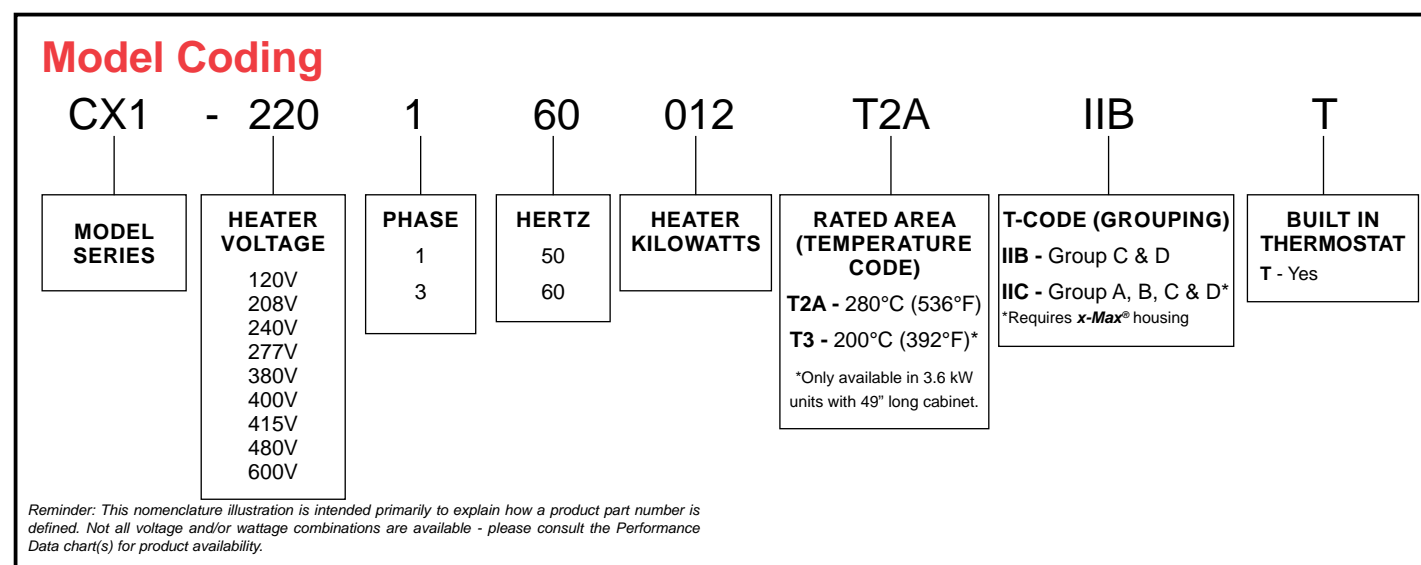

CX1 ProVector® Physical Dimensions with Defender® housing

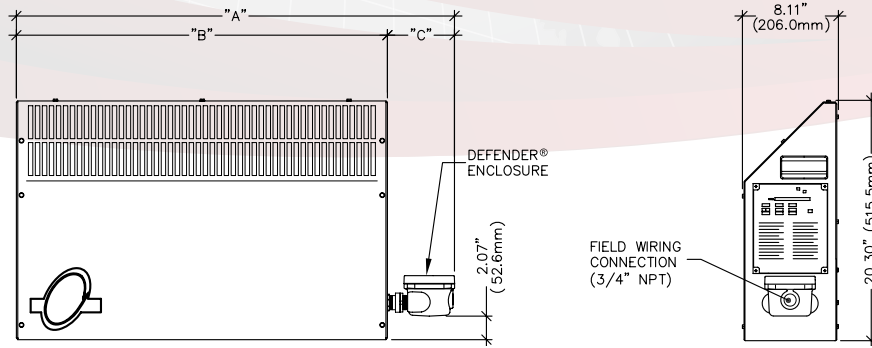

Heater kW Rating	'A' Dimension		'B' Dimension	'C' Dimension	
	w/o Extension	w/ Extension		w/o Extension	w/ Extension
	in. (mm)	in. (mm)	in. (mm)	in. (mm)	in. (mm)
0.75 – 2.69 & 3.6 (T2A)	36.9 (938)	39.0 (991)	31.34 (796)	5.6 (142)	7.7 (195)
3.01 – 3.59, 3.6 (T3) & 4.8	55.0 (1398)	57.1 (1451)	49.45 (1256)		
4.76, 5.28 – 7.6*	65.1 (1653)	67.2 (1706)	59.49 (1511)		
3.13, 3.47, 3.74, 5.0, 6.26, 6.94, 7.47 & 10.0	77.4 (1965)	79.4 (2018)	71.78 (1823)		

* Except 7.6 kW, 208, 3Ø and 10 kW, 208V, & 277V, 3Ø units

** 1Ø Thermostat units require extension

CX1 ProVector® Physical Dimensions with x-Max® housing

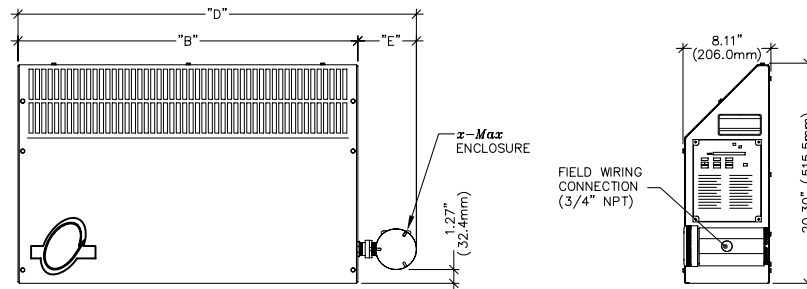

Heater kW Rating	'D' Dimension			'B' Dimension	'E' Dimension		
	1Ø w/o Extension	1Ø** w/ Extension	3Ø Units		w/o Extension	w/ Extension	3Ø Units
	in. (mm)	in. (mm)	in. (mm)	in. (mm)	in. (mm)	in. (mm)	in. (mm)
0.75 – 2.69 & 3.6 (T2A)	37.6 (954)	39.6 (1007)	38.3 (973)	31.34 (796)	6.2 (158)	8.3 (211)	7.0 (177)
3.01 – 3.59, 3.6 (T3) & 4.8	55.7 (1414)	57.8 (1467)	56.4 (1433)	49.45 (1256)			
4.76, 5.28 – 7.6*	65.7 (1669)	67.8 (1722)	66.5 (1688)	59.49 (1511)			
3.13, 3.47, 3.74, 5.0, 6.26, 6.94, 7.47 & 10.0	78.0 (1981)	80.1 (2034)	78.7 (2000)	71.78 (1823)			

** 1Ø Thermostat units require extension

CX1 ProVector® Physical Dimensions with FX4 housing

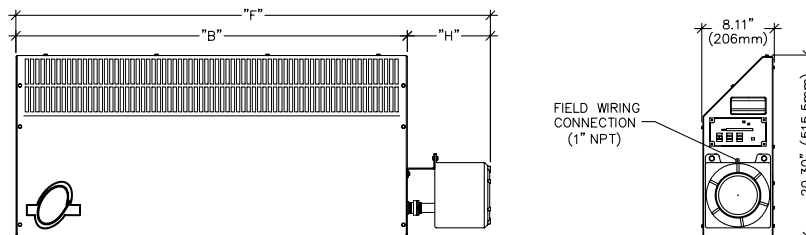

Heater kW Rating	'F' Dimension		'B' Dimension	'H' Dimension	
	w/o Extension	w/ Extension		w/o Extension	w/ Extension
	in. (mm)	in. (mm)	in. (mm)	in. (mm)	in. (mm)
7.6 kW, 208, 3Ø and 10 kW, 208V, & 277V, 3Ø units	81.1 (2060)	N/A	71.77 (1823)	9.3 (236)	N/A

CX1 ProVector®

CX1 TECHNICAL DATA - 1 PHASE

MODEL CODE	KW (BTU/HR)	UNIT VOLTAGE (VOLTS)	PHASE	BASIC UNIT	GAS GROUP				SUPPLY WIRE SIZE (AWG) ^{***}	UNIT CURRENT (AMPS)	MAXIMUM CIRCUIT FUSE (AMPS) [*]	CABINET LENGTH IN (MM)	TEMP CODE		
					IIB + H2		IIB							IIC	
					W/O T'STAT	W/ T'STAT	W/O T'STAT	W/ T'STAT						W/O T'STAT	W/ T'STAT
CX1-120160-012-T3	1.2 (4095)	120	1	✓	✓	✓	✓	✓	12	10.0	15	31.3 (796)	T3 (200)		
CX1-120160-018-T3	1.8 (6142)	120	1	✓	✓	✓	✓	✓	12	15.0	20	31.3 (796)	T3 (200)		
CX1-208160-012-T3	1.2 (4095)	208	1	✓	✓	✓	✓	✓	12	5.8	15	31.3 (796)	T3 (200)		
CX1-208160-018-T3	1.8 (6142)	208	1	✓	✓	✓	✓	✓	12	8.7	15	31.3 (796)	T3 (200)		
CX1-208160-036-T3**	3.6 (12284)	208	1	✓	✓	✓	✓	✓	12	17.3	20	49.5 (1256)	T3 (200)		
CX1-208160-048-T2A	4.8 (16378)	208	1	✓	✓	N/A	✓	✓	8	23.1	25	49.5 (1256)	T2A (280)		
CX1-208160-050-T3	5.0 (17060)	208	1	✓	✓	N/A	✓	✓	8	24.0	30	71.8 (1823)	T3 (200)		
CX1-208160-076-T2A	7.6 (25932)	208	1	✓	✓	N/A	✓	N/A	8	36.5	40	59.5 (1511)	T2A (280)		
CX1-240160-012-T3	1.2 (4095)	240	1	✓	✓	✓	✓	✓	12	5.0	15	31.3 (796)	T3 (200)		
CX1-240160-018-T3	1.8 (6142)	240	1	✓	✓	✓	✓	✓	12	7.5	15	31.3 (796)	T3 (200)		
CX1-240160-036-T3**	3.6 (12284)	240	1	✓	✓	✓	✓	✓	12	15.0	20	49.5 (1256)	T3 (200)		
CX1-240160-048-T2A	4.8 (16378)	240	1	✓	✓	✓	✓	✓	10	20.0	25	49.5 (1256)	T2A (280)		
CX1-240160-050-T3	5.0 (17060)	240	1	✓	✓	✓	✓	✓	8	20.8	30	71.8 (1823)	T3 (200)		
CX1-240160-076-T2A	7.6 (25932)	240	1	✓	✓	N/A	✓	N/A	8	31.7	35	59.5 (1511)	T2A (280)		
CX1-277160-012-T3	1.2 (4095)	277	1	✓	✓	✓	✓	✓	12	4.3	15	31.3 (796)	T3 (200)		
CX1-277160-018-T3	1.8 (6142)	277	1	✓	✓	✓	✓	✓	12	6.5	15	31.3 (796)	T3 (200)		
CX1-277160-036-T3**	3.6 (12284)	277	1	✓	✓	✓	✓	✓	12	13.0	15	49.5 (1256)	T3 (200)		
CX1-277160-048-T2A	4.8 (16378)	277	1	✓	✓	✓	✓	✓	12	17.3	20	49.5 (1256)	T2A (280)		
CX1-277160-050-T3	5.0 (17060)	277	1	✓	✓	✓	✓	✓	8	18.1	25	71.8 (1823)	T3 (200)		
CX1-277160-076-T2A	7.6 (25932)	277	1	✓	✓	N/A	✓	N/A	8	27.4	30	59.5 (1511)	T2A (280)		
CX1-380160-0075-T3	0.75 (2560)	380	1	✓	✓	✓	+	+	12	2.0	15	31.3 (796)	T3 (200)		
CX1-380160-0113-T3	1.13 (3856)	380	1	✓	✓	✓	+	+	12	3.0	15	31.3 (796)	T3 (200)		
CX1-380160-012-T3	1.2 (4095)	380	1	✓	✓	✓	✓	✓	12	3.2	15	31.3 (796)	T3 (200)		
CX1-380160-018-T3	1.8 (6142)	380	1	✓	✓	✓	✓	✓	12	4.7	15	31.3 (796)	T3 (200)		
CX1-380160-0226-T2A	2.26 (7711)	380	1	✓	✓	✓	+	+	12	5.9	15	31.3 (796)	T2A (280)		
CX1-380160-0301-T3	3.01 (10271)	380	1	✓	✓	✓	+	+	12	7.9	15	49.5 (1256)	T3 (200)		
CX1-380160-0313-T3	3.13 (10680)	380	1	✓	✓	✓	+	+	12	8.2	15	71.8 (1823)	T3 (200)		
CX1-380160-036-T3**	3.6 (12284)	380	1	✓	✓	✓	✓	✓	12	9.5	15	49.5 (1256)	T3 (200)		
CX1-380160-0476-T2A	4.76 (16241)	380	1	✓	✓	✓	+	+	10	12.5	15	59.5 (1511)	T2A (280)		
CX1-380160-048-T2A	4.8 (16378)	380	1	✓	✓	✓	✓	✓	12	12.6	15	49.5 (1256)	T2A (280)		
CX1-380160-050-T3	5.0 (17060)	380	1	✓	✓	✓	✓	✓	10	13.2	20	71.8 (1823)	T3 (200)		
CX1-380160-0626-T2A	6.26 (21360)	380	1	✓	✓	✓	✓	N/A	8	16.5	25	71.8 (1823)	T2A (280)		
CX1-380160-076-T2A	7.6 (25932)	380	1	✓	✓	✓	✓	N/A	10	20.0	25	59.5 (1511)	T2A (280)		
CX1-380160-100-T2A	10.0 (34121)	380	1	✓	✓	N/A	✓	N/A	8	26.3	40	71.8 (1823)	T2A (280)		
CX1-400160-0083-T3	0.83 (2832)	400	1	✓	✓	✓	+	+	12	2.1	15	31.3 (796)	T3 (200)		
CX1-400160-012-T3	1.2 (4095)	400	1	✓	✓	✓	✓	✓	12	3.0	15	31.3 (796)	T3 (200)		
CX1-400160-0125-T3	1.25 (4565)	400	1	✓	✓	✓	+	+	12	3.1	15	31.3 (796)	T3 (200)		
CX1-400160-018-T3	1.8 (6142)	400	1	✓	✓	✓	✓	✓	12	4.5	15	31.3 (796)	T3 (200)		
CX1-400160-025-T2A	2.5 (8530)	400	1	✓	✓	✓	+	+	12	6.3	15	31.3 (796)	T2A (280)		
CX1-400160-0333-T3	3.33 (11362)	400	1	✓	✓	✓	+	+	12	8.3	15	49.5 (1256)	T3 (200)		
CX1-400160-0347-T3	3.47 (11840)	400	1	✓	✓	✓	✓	✓	12	8.7	15	71.8 (1823)	T3 (200)		
CX1-400160-036-T3**	3.6 (12284)	400	1	✓	✓	✓	✓	✓	12	9.0	15	49.5 (1256)	T3 (200)		
CX1-400160-048-T2A	4.8 (16378)	400	1	✓	✓	✓	✓	✓	12	12.0	15	49.5 (1256)	T2A (280)		
CX1-400160-050-T3	5.0 (17060)	400	1	✓	✓	✓	✓	✓	10	12.5	15	71.8 (1823)	T3 (200)		
CX1-400160-0528-T2A	5.28 (18016)	400	1	✓	✓	✓	+	+	10	13.2	15	59.5 (1511)	T2A (280)		
CX1-400160-0694-T2A	6.94 (23680)	400	1	✓	✓	✓	✓	N/A	8	17.4	25	71.8 (1823)	T2A (280)		
CX1-400160-076-T2A	7.6 (25932)	400	1	✓	✓	✓	✓	N/A	10	19.0	20	59.5 (1511)	T2A (280)		

CX1 TECHNICAL DATA - 1 PHASE (cont.)

MODEL CODE	KW (BTU/HR)	UNIT VOLTAGE (VOLTS)	PHASE	BASIC UNIT	GAS GROUP				SUPPLY WIRE SIZE (AWG)***	UNIT CURRENT (AMPS)	MAXIMUM CIRCUIT FUSE (AMPS)*	CABINET LENGTH IN (MM)	TEMP CODE		
					IIB + H2		IIB							IIC	
					W/O T'STAT	W/ T'STAT	W/O T'STAT	W/ T'STAT						W/O T'STAT	W/ T'STAT
CX1-400160-100-T2A	10.0 (34121)	400	1	✓	✓	N/A	✓	N/A	8	25.0	40	71.8 (1823)	T2A (280)		
CX1-415160-009-T3	0.9 (3071)	415	1	✓	✓	✓	+	+	12	2.2	15	31.3 (796)	T3 (200)		
CX1-415160-012-T3	1.2 (4095)	415	1	✓	✓	✓	✓	✓	12	2.9	15	31.3 (796)	T3 (200)		
CX1-415160-0135-T3	1.35 (4606)	415	1	✓	✓	✓	+	+	12	3.3	15	31.3 (796)	T3 (200)		
CX1-415160-018-T3	1.8 (6142)	415	1	✓	✓	✓	✓	✓	12	4.3	15	31.3 (796)	T3 (200)		
CX1-415160-0269-T2A	2.69 (9179)	415	1	✓	✓	✓	+	+	12	6.5	15	31.3 (796)	T2A (280)		
CX1-415160-0359-T3	3.59 (12250)	415	1	✓	✓	✓	+	+	12	8.7	15	49.5 (1256)	T3 (200)		
CX1-415160-036-T3**	3.6 (12284)	415	1	✓	✓	✓	✓	✓	12	8.7	15	49.5 (1256)	T3 (200)		
CX1-415160-0374-T3	3.74 (12761)	415	1	✓	✓	✓	✓	✓	12	9.0	15	71.8 (1823)	T3 (200)		
CX1-415160-048-T2A	4.8 (16378)	415	1	✓	✓	✓	✓	✓	12	11.6	15	49.5 (1256)	T2A (280)		
CX1-415160-050-T3	5.0 (17060)	415	1	✓	✓	✓	✓	✓	12	12.0	15	71.8 (1823)	T3 (200)		
CX1-415160-0568-T2A	5.68 (19381)	415	1	✓	✓	✓	+	+	10	13.7	15	59.5 (1511)	T2A (280)		
CX1-415160-0747-T2A	7.47 (25488)	415	1	✓	✓	✓	✓	N/A	8	18.0	25	71.8 (1823)	T2A (280)		
CX1-415160-076-T2A	7.6 (25932)	415	1	✓	✓	✓	✓	N/A	10	18.3	20	59.5 (1511)	T2A (280)		
CX1-415160-100-T2A	10.0 (34121)	415	1	✓	✓	N/A	✓	N/A	8	24.1	30	71.8 (1823)	T2A (280)		
CX1-480160-012-T3	1.2 (4095)	480	1	✓	✓	✓	✓	✓	12	2.5	15	31.3 (796)	T3 (200)		
CX1-480160-018-T3	1.8 (6142)	480	1	✓	✓	✓	✓	✓	12	3.8	15	31.3 (796)	T3 (200)		
CX1-480160-036-T3**	3.6 (12284)	480	1	✓	✓	✓	✓	✓	12	7.5	15	49.5 (1256)	T3 (200)		
CX1-480160-048-T2A	4.8 (16378)	480	1	✓	✓	✓	✓	✓	12	10.0	15	49.5 (1256)	T2A (280)		
CX1-480160-050-T3	5.0 (17060)	480	1	✓	✓	✓	✓	✓	12	10.4	15	71.8 (1823)	T3 (200)		
CX1-480160-076-T2A	7.6 (25932)	480	1	✓	✓	✓	✓	N/A	10	15.8	20	59.5 (1511)	T2A (280)		
CX1-480160-100-T2A	10.0 (34121)	480	1	✓	✓	✓	✓	N/A	8	20.8	30	71.8 (1823)	T2A (280)		
CX1-600160-012-T3	1.2 (4095)	600	1	✓	✓	N/A	✓	✓	12	2.0	15	31.3 (796)	T3 (200)		
CX1-600160-018-T3	1.8 (6142)	600	1	✓	✓	N/A	✓	✓	12	3.0	15	31.3 (796)	T3 (200)		
CX1-600160-036-T3**	3.6 (12284)	600	1	✓	✓	N/A	✓	✓	12	6.0	15	49.5 (1256)	T3 (200)		
CX1-600160-048-T2A	4.8 (16378)	600	1	✓	✓	N/A	✓	✓	12	8.0	15	49.5 (1256)	T2A (280)		
CX1-600160-050-T3	5.0 (17060)	600	1	✓	✓	N/A	✓	✓	12	8.3	15	71.8 (1823)	T3 (200)		
CX1-600160-076-T2A	7.6 (25932)	600	1	✓	✓	N/A	✓	✓	12	12.7	15	59.5 (1511)	T2A (280)		
CX1-600160-100-T2A	10.0 (34121)	600	1	✓	✓	N/A	✓	N/A	10	16.7	25	71.8 (1823)	T2A (280)		

* Or equivalent breaker as per local electrical inspection authority requirements.

** For 3.6 kW heaters rated T3 cabinet length is 49.5" (1256mm). 3.6 kW heaters rated T2A cabinet length is 31.3" (796mm).

*** Ensure supply wire size adheres to applicable local and national electrical codes.

+ Available in 50 Hz only.

Notes

1. Heater is functioning normally if, at rated voltage, the current draw is within 10% of the value in this table.
2. Operation at lower voltages that rated will result in reduced output and current draw.
Actual Output (kW) = [(Supply Voltage)² ÷ (Rated Voltage)²] × Rated Unit Wattage (kW)]
3. Add suffix "T" for optional built-in thermostat. Thermostat not available on IIB + H2 models.
4. Add suffix "H" for high-temperature ambient storage option. High temperature storage option is not available with thermostat option. Not available on IIB models.
5. For IIB model with XCT built-in thermostat - Class I, Div. 1 & 2, Groups C & D; Zones 1 & 2, Groups IIA and IIB.
6. For IIC model with XT built-in thermostat - Class I, Div. 1 & 2, Groups A,B,C & D; Zones 1 & 2, Groups IIA, IIB, IIC.
7. IIC Grouping units come with **x-Max**® housing.
8. Remote mounted, Defender, explosion-proof room thermostats are not suitable for Group B & IIC applications.
9. Remote contactors are required on all 600V heaters, and heaters with a current draw greater than 22 amps (supplied & installed by others), when utilizing XT-311 remote thermostat.
10. Temperature code ratings: T2A - 280°C (536°F), T3 - 200°C (392°F)

CX1 TECHNICAL DATA - 3 PHASE

Model	kW (Btu/hr)	Unit Voltage V	Gas Group				Supply Wire Size *** AWG	Unit Current A	Max. Circuit Fuse* A	Cabinet Length in (mm)	Temperature Code
			IIB + H2	IIB	IIC						
			w/o T'stat	w/ T'stat	w/o T'stat	w/ T'stat					
CX1-208360-012-T3	1.2 (4095)	208	✓		✓	✓	14	3.3	15	31.3 (796)	T3 (200)
CX1-208360-018-T3	1.8 (6142)	208	✓		✓	✓	14	5.0	15	31.3 (796)	T3 (200)
CX1-208360-036-T3**	3.6 (12284)	208	✓		✓	✓	12	10.0	15	49.5 (1256)	T3 (200) T2A (280)
CX1-208360-048-T2A	4.8 (16378)	208	✓		✓	✓	10	13.3	20	49.5 (1256)	T2A (280)
CX1-208360-050-T3	5.0 (17060)	208	✓		✓	✓	10	13.9	20	71.8 (1823)	T3 (200)
CX1-208360-076-T2A	7.6 (25932)	208	•		N/A	N/A	10	21.1	30	59.5 (1511)	T2A (280)
CX1-208360-100-T2A	10.0 (34121)	208	•		N/A	N/A	8	27.8	35	71.8 (1823)	T2A (280)
CX1-240360-012-T3	1.2 (4095)	240	✓		✓	✓	14	2.9	15	31.3 (796)	T3 (200)
CX1-240360-018-T3	1.8 (6142)	240	✓		✓	✓	14	4.3	15	31.3 (796)	T3 (200)
CX1-240360-036-T3**	3.6 (12284)	240	✓		✓	✓	14	8.7	15	49.5 (1256)	T3 (200) T2A (280)
CX1-240360-048-T2A	4.8 (16378)	240	✓		✓	✓	12	11.5	20	49.5 (1256)	T2A (280)
CX1-240360-050-T3	5.0 (17060)	240	✓		✓	✓	14	12.0	15	71.8 (1823)	T3 (200)
CX1-240360-076-T2A	7.6 (25932)	240	✓		✓	✓	10	18.3	25	59.5 (1511)	T2A (280)
CX1-240360-100-T2A	10.0 (34121)	240	•		N/A	N/A	8	24.1	35	71.8 (1823)	T2A (280)
CX1-277360-012-T3	1.2 (4095)	277	✓		✓	✓	14	2.5	15	31.3 (796)	T3 (200)
CX1-277360-018-T3	1.8 (6142)	277	✓		✓	✓	14	3.8	15	31.3 (796)	T3 (200)
CX1-277360-036-T3**	3.6 (12284)	277	✓		✓	✓	14	7.5	15	49.5 (1256)	T3 (200) T2A (280)
CX1-277360-048-T2A	4.8 (16378)	277	✓		✓	✓	14	10.0	15	49.5 (1256)	T2A (280)
CX1-277360-050-T3	5.0 (17060)	277	✓	N/A	✓	✓	14	10.4	15	71.8 (1823)	T3 (200)
CX1-277360-076-T2A	7.6 (25932)	277	✓		✓	✓	12	15.8	20	59.5 (1511)	T2A (280)
CX1-277360-100-T2A	10.0 (34121)	277	•		N/A	N/A	10	20.8	30	71.8 (1823)	T2A (280)
CX1-380360-0113-T3	1.13 (3856)	380	✓		+	+	14	1.7	15	31.3 (796)	T3 (200)
CX1-380360-0226-T2A	2.26 (7711)	380	✓		+	+	14	3.4	15	31.3 (796)	T2A (280)
CX1-380360-0301-T3	3.01 (10271)	380	✓		+	+	14	4.6	15	49.5 (1256)	T3 (200)
CX1-380360-0313-T3	3.13 (10680)	380	✓		+	+	14	4.8	15	71.8 (1823)	T3 (200)
CX1-380360-0476-T2A	4.76 (16241)	380	✓		+	+	14	7.2	15	59.5 (1511)	T2A (280)
CX1-380360-050-T3	5.0 (17060)	380	✓		✓	✓	14	7.6	15	71.8 (1823)	T3 (200)
CX1-380360-0626-T2A	6.26 (21360)	380	✓		✓	✓	14	9.5	15	71.8 (1823)	T2A (280)
CX1-380360-100-T2A	10.0 (34121)	380	✓		✓	✓	12	15.2	20	71.8 (1823)	T2A (280)
CX1-400360-0125-T3	1.25 (4565)	400	✓		+	+	14	1.8	15	31.3 (796)	T3 (200)
CX1-400360-025-T2A	2.5 (8530)	400	✓		+	+	14	3.6	15	31.3 (796)	T2A (280)
CX1-400360-0333-T3	3.33 (11362)	400	✓		+	+	14	4.8	15	49.5 (1256)	T3 (200)
CX1-400360-0347-T3	3.47 (11840)	400	✓		✓	✓	14	5.0	15	71.8 (1823)	T3 (200)
CX1-400360-050-T3	5.0 (17060)	400	✓		✓	✓	14	7.2	15	71.8 (1823)	T3 (200)
CX1-400360-0528-T2A	5.28 (18016)	400	✓		+	+	14	7.6	15	59.5 (1511)	T2A (280)
CX1-400360-0694-T2A	6.94 (23680)	400	✓		✓	✓	14	1.0	15	71.8 (1823)	T3 (200)
CX1-400360-100-T2A	10.0 (34121)	400	✓		✓	✓	12	14.4	20	71.8 (1823)	T2A (280)
CX1-415360-0135-T3	1.35 (4606)	415	✓		+	+	14	1.9	15	31.3 (796)	T3 (200)
CX1-415360-0269-T2A	2.69 (9179)	415	✓		+	+	14	3.7	15	31.3 (796)	T2A (280)
CX1-415360-0359-T3	3.59 (12250)	415	✓		+	+	14	5.0	15	49.5 (1256)	T3 (200)
CX1-415360-0374-T3	3.74 (12761)	415	✓		✓	✓	14	5.2	15	71.8 (1823)	T3 (200)

CX1 TECHNICAL DATA - 3 PHASE (con't)

Model	kW (Btu/hr)	Unit Voltage	Gas Group				Supply Wire Size ***	Unit Current	Max. Circuit Fuse*	Cabinet Length	Temperature Code
			IIB + H2	IIB	IIC						
		V	w/o T'stat	w/ T'stat	w/o T'stat	w/ T'stat	AWG	A	A	in (mm)	
CX1-415360-050-T3	5.0 (17060)	415	✓		✓	✓	14	7.0	15	71.8 (1823)	T3 (200)
CX1-415360-0568-T2A	5.68 (19381)	415	✓			+	+	14	15	59.5 (1511)	T2A (280)
CX1-415360-0747-T2A	7.47 (25488)	415	✓		✓	✓	14	10.4	15	71.8 (1823)	T2A (280)
CX1-415360-100-T2A	10.0 (34121)	415	✓		✓	✓	12	13.9	20	71.8 (1823)	T2A (280)
CX1-480360-018-T3	1.8 (6142)	480	✓		✓	✓	14	2.2	15	31.3 (796)	T3 (200)
CX1-480360-036-T3**	3.6 (12284)	480	✓		✓	✓	14	4.3	15	49.5 (1256)	T3 (200)
											T2A (280)
CX1-480360-048-T2A	4.8 (16378)	480	✓		✓	✓	14	5.8	15	49.5 (1256)	T2A (280)
CX1-480360-050-T3	5.0 (17060)	480	✓		✓	✓	14	6.0	15	71.8 (1823)	T3 (200)
CX1-480360-076-T2A	7.6 (25932)	480	✓		✓	✓	14	9.1	15	59.5 (1511)	T2A (280)
CX1-480360-100-T2A	10.0 (34121)	480	✓		✓	✓	14	12.0	15	71.8 (1823)	T2A (280)
CX1-600360-036-T3**	3.6 (12284)	600	✓		✓	✓	14	3.5	15	49.5 (1256)	T3 (200)
											T2A (280)
CX1-600360-048-T2A	4.8 (16378)	600	✓		✓	✓	14	4.6	15	49.5 (1256)	T2A (280)
CX1-600360-050-T3	5.0 (17060)	600	✓		✓	✓	14	4.8	15	71.8 (1823)	T3 (200)
CX1-600360-076-T2A	7.6 (25932)	600	✓		✓	✓	14	7.3	15	59.5 (1511)	T2A (280)
CX1-600360-100-T2A	10.0 (34121)	600	✓		✓	✓	14	9.6	15	71.8 (1823)	T2A (280)

* Or equivalent breaker as per local electrical inspection authority requirements

** For 3.6 kW heaters rated T3 cabinet length is 49.5" (1256mm). 3.6 kW heaters rated T2A cabinet length is 31.3" (796mm)

*** Ensure supply wire size adheres to applicable local and national electrical code

+ Available in 50 Hz only

• For IIB only

Notes

1. Heater is functioning normally if, at rated voltage, the current draw is within 10% of the value in this table.
2. Operation at lower voltages that rated will result in reduced output and current draw.
Actual Output (kW) = [(Supply Voltage)² ÷ (Rated Voltage)²] × Rated Unit Wattage (kW)]
3. Add suffix "T" for optional built-in thermostat. Thermostat not available on IIB + H2 models.
4. Add suffix "H" for high-temperature ambient storage option. High temperature storage option is not available with thermostat option. Not available on IIB models.
5. For IIB model with XCT built-in thermostat - Class I, Div. 1 & 2, Groups C & D; Zones 1 & 2, Groups IIA and IIB
6. For IIC model with XT built-in thermostat - Class I, Div. 1 & 2, Groups A,B,C & D; Zones 1 & 2, Groups IIA, IIB, IIC
7. IIC Grouping units come with **x-Max**® housing.
8. Remote mounted, Defender, explosion-proof room thermostats are not suitable for Group B & IIC applications.
9. Remote contactors are required on all 600V heaters, and heaters with a current draw greater than 22 amps (supplied & installed by others), when utilizing XT-311 remote thermostat.
10. Temperature code ratings: T2A - 280°C (536°F), T3 - 200°C (392°F)

CX1 ProVector®

CF1 ProVector® Explosion-Proof Heaters

The Ruffneck™ CF1 Series ProVector® Explosion-proof convection heater offers the most reliable, dependable and trouble-free service available for heating hazardous locations such as those in the oil and gas well industry. The CF1 ProVector® Explosion-proof heater offers the following outstanding features and benefits:

Feature

- sloped-top cabinet
- no exposed copper or brass
- high-velocity airflow
- 14-gauge steel cabinet, available with stainless steel construction
- one of the shortest cabinet lengths available
- optional built-in thermostat
- Incoloy® 840 heating elements
- radial-embossed aluminum plate fins
- galvanized steel mounting brackets
- approvals for groups IIA, IIB & IIC

Benefit

- prevents objects from being set on top which restricts airflow
- corrosion resistant, suitable for H₂S environments
- heats up area faster with better heat distribution
- rugged reliability and unsurpassed corrosion resistance available with stainless steel construction
- smaller profile utilizes less wall and floor space
- reduced field installation costs
- longer life expectancy
- reduced fin warping for better heat transfer capabilities
- quick installation
- industry first approvals for built-in thermostat with IIA, IIB, IIC ratings



CF1 ProVector®

CF1 ProVector® General Specifications

Approvals	
Hazardous Location Classifications	Defender® housing; Zones 1 & 2, Groups IIA, IIB
Without Built-In Thermostat	x-Max ® housing; Zones 1 & 2, Groups IIA, IIB, & IIC
With Built-In Thermostat	XCT Defender® thermostat: Zones 1 & 2, Groups IIA & IIB XT thermostat: Zones 1 & 2, Groups IIA, IIB, & IIC
Enclosure	Cast or extruded aluminum supplied with either a bolt-on cover or two screwed-on covers. Suitable for either a Defender® or x-Max ® thermostat.
Mounting Brackets	Two 14-gauge (2 mm / 0.075") galvanized steel brackets for standard cabinet Stainless-steel brackets provided with optional stainless-steel cabinet
Heating Elements	Two Incoloy® 840 sheathed elements
Temperature Code Rating	Temperature Code T2 - 300°C (572°F), T3 - 200°C (392°F) or T4 - 135°C (275°F)
Temperature Limitations	Operational: -45°C to 40°C (-49°F to 104°F) Storage: -45°C to 80°C (-49°F to 176°F). optional up to 149°C (300°F) available
Cabinet Material	14-gauge (2 mm / 0.075") epoxy coated steel with galvanized rear panel Optional 14-gauge 304 stainless-steel cabinet and mounting hardware available

Nominal kW		0.75 - 3.00 (220V) & 3.30 (T2), 3.60 (T2)	3.00 - 4.40 & 4.80 (240V)	4.80 (380V) - 7.60
Cabinet Length	mm (in)	796 (31.3)	1256 (49.4)	1511 (59.5)
Net weight	(kg)	27	39	43.6
	(lbs)	58	86	96
Shipping weight	(kg)	30	44	48
	(lbs)	65	95	105

Model Coding

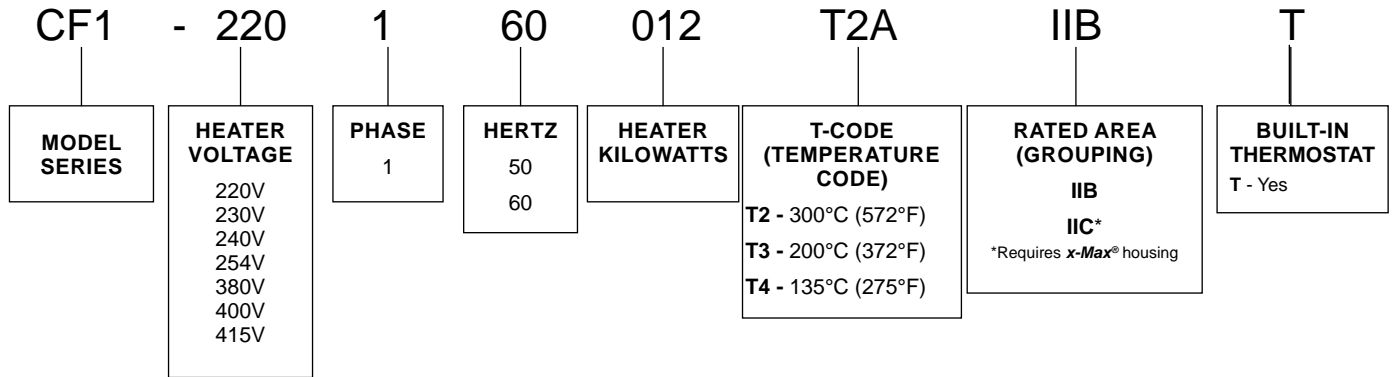

Note:

This nomenclature illustration is intended primarily to explain how a product part number is defined. Not all voltage and/or wattage combinations are available - please consult the catalogue chart(s) for product availability.

CF1 ProVector® Physical Dimensions with x-Max® housing

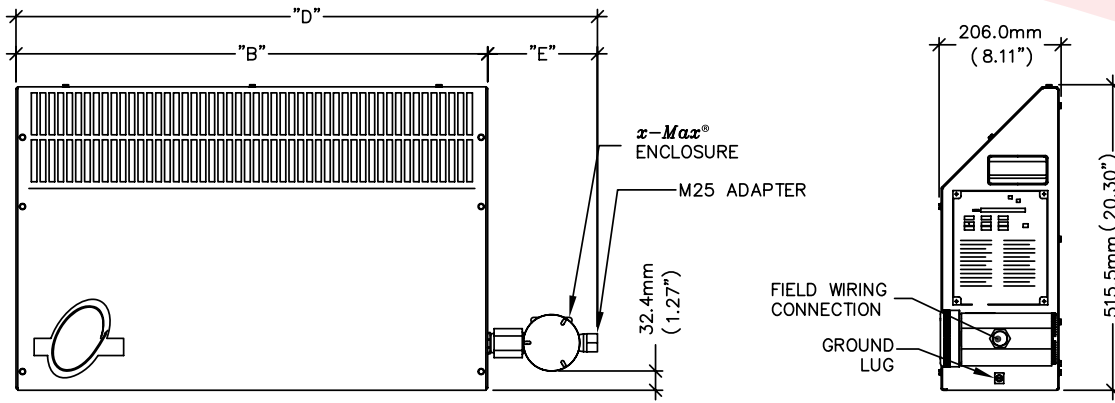

HEATER KW RATING	"D" DIMENSION		"B" DIMENSION	"E" DIMENSION	
	W/O EXTENSION	WITH EXTENSION		W/O EXTENSION	WITH EXTENSION
0.75 – 3.00 (220V) & 3.30 (T2) – 3.60 (T2)	984mm (38.7")	1037mm (40.8")	796.0mm (31.34")	188mm (7.4")	241mm (9.5")
3.00 – 4.40 & 4.80 (240V)	1444mm (56.9")	1497mm (58.9")	1256.0mm (49.45")	188mm (7.4")	241mm (9.5")
4.80 (380V) – 7.60	1699mm (66.9")	1752mm (69.0")	1511.0mm (59.49")	188mm (7.4")	241mm (9.5")

CF1 ProVector® Physical Dimensions with Defender® housing

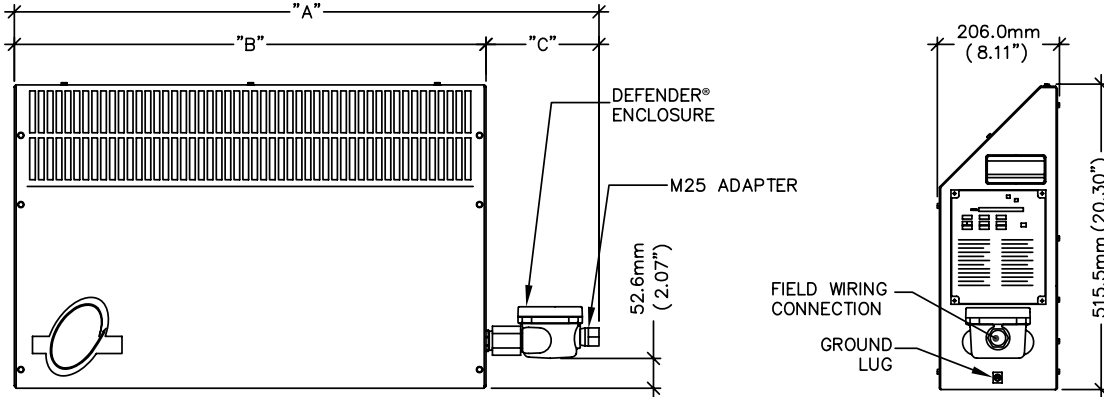

HEATER KW RATING	"A" DIMENSION		"B" DIMENSION	"C" DIMENSION	
	W/O EXTENSION	WITH EXTENSION		W/O EXTENSION	WITH EXTENSION
0.75 – 3.00 (220V) & 3.30 (T2) – 3.60 (T2)	973mm (38.3")	1026mm (40.4")	796.0mm (31.34")	177mm (7.0")	230mm (9.1")
3.00 – 4.40 & 4.80 (240V)	1433mm (56.4")	1486mm (58.5")	1256.0mm (49.45")	177mm (7.0")	230mm (9.1")
4.80 (380V) – 7.60	1688mm (66.5")	1741mm (68.5")	1511.0mm (59.49")	177mm (7.0")	230mm (9.1")

Notes: Heaters with built-in thermostat come with tube extensions.

Performance Data for CF1 ProVector®

MODEL NUMBER	kW (BTU/hr)	UNIT VOLTAGE (VOLTS)	BASIC UNIT	GAS GROUP				SUPPLY WIRE SIZE (AWG)***	UNIT CURRENT (AMPS)	MAXIMUM CIRCUIT FUSE (AMPS)*	CABINET LENGTH mm (in)	TEMP. CODE
				IIB		IIC						
				W/O T'STAT	W/ T'STAT	W/O T'STAT	W/ T'STAT					
CF1-220150-010-T4	1.0 (3412)	220	X	X	X	X	X	12	4.6	15	796 (31.3)	T4
CF1-220150-015-T3	1.5 (5118)	220	X	X	X	X	X	12	6.9	15	796 (31.3)	T3
CF1-220150-030-T2	3.0 (10236)	220	X	X	X			12	13.8	15	796 (31.3)	T2
CF1-220150-040-T3	4.0 (13648)	220	X	X	X			10	18.3	20	1256 (49.4)	T3
CF1-220150-064-T2**	6.4 (21837)	220	X	X				8	29.0	30	1511 (59.5)	T2
CF1-230150-011-T4	1.1 (3753)	230	X	X	X	X	X	12	4.8	15	796 (31.3)	T4
CF1-230150-017-T3	1.7 (5801)	230	X	X	X	X	X	12	7.2	15	796 (31.3)	T3
CF1-230150-030-T3	3.0 (10236)	230	X	X	X	X	X	12	13.0	15	1256 (49.4)	T3
CF1-230150-033-T2	3.3 (11260)	230	X	X	X			10	14.4	15	796 (31.3)	T2
CF1-230150-044-T2	4.4 (15013)	230	X	X	X			10	19.2	20	1256 (49.4)	T2
CF1-230150-070-T2**	7.0 (23885)	230	X	X				8	30.3	35	1511 (59.5)	T2
CF1-240150-012-T4	1.2 (4095)	240	X	X	X	X	X	12	5.0	15	796 (31.3)	T4
CF1-240150-018-T3	1.8 (6142)	240	X	X	X	X	X	12	7.5	15	796 (31.3)	T3
CF1-240150-030-T3	3.0 (10236)	240	X	X	X	X	X	12	12.5	15	1256 (49.4)	T3
CF1-240150-036-T2	3.6 (12284)	240	X	X	X			10	15.0	20	796 (31.3)	T2
CF1-240150-048-T2	4.8 (16378)	240	X	X	X			10	20.0	25	1256 (49.4)	T2
CF1-240150-076-T2**	7.6 (25932)	240	X	X				8	31.7	35	1511 (59.5)	T2
CF1-254150-030-T3	3.0 (10236)	254	X	X	X	X	X	12	11.8	15	1256 (49.4)	T3
CF1-380150-0075-T4	0.75 (2559)	380	X	X	X	X	X	12	2.0	15	796 (31.3)	T4
CF1-380150-011-T4	1.1 (3753)	380	X	X	X	X	X	12	3.0	15	796 (31.3)	T4
CF1-380150-023-T3	2.3 (7848)	380	X	X	X			12	5.9	15	796 (31.3)	T3
CF1-380150-030-T3	3.0 (10236)	380	X	X	X	X	X	12	7.9	15	1256 (49.4)	T3
CF1-380150-036-T3	3.6 (12284)	380	X			X	X	12	9.4	15	1256 (49.4)	T3
CF1-380150-048-T2	4.8 (16378)	380	X	X	X			12	12.5	15	1511 (59.5)	T2
CF1-400150-0083-T4	0.83 (2832)	400	X	X	X	X	X	12	2.1	15	796 (31.3)	T4
CF1-400150-013-T4	1.3 (4436)	400	X	X	X	X	X	12	3.1	15	796 (31.3)	T4
CF1-400150-025-T3	2.5 (8530)	400	X	X	X			12	6.3	15	796 (31.3)	T3
CF1-400150-033-T3	3.3 (11260)	400	X	X	X	X	X	12	8.3	15	1256 (49.4)	T3
CF1-400150-036-T3	3.6 (12284)	400	X			X	X	12	9.0	15	1256 (49.4)	T3
CF1-400150-053-T2	5.3 (18084)	400	X	X	X			12	13.2	15	1511 (59.5)	T2
CF1-415150-009-T4	0.90 (3071)	415	X	X	X	X	X	12	2.2	15	796 (31.3)	T4
CF1-415150-014-T4	1.4 (4777)	415	X	X	X	X	X	12	3.2	15	796 (31.3)	T4
CF1-415150-027-T2	2.7 (9213)	415	X	X	X			12	6.5	15	796 (31.3)	T2
CF1-415150-036-T3	3.6 (12284)	415	X	X	X	X	X	12	8.7	15	1256 (49.4)	T3
CF1-415150-057-T2	5.7 (19449)	415	X	X	X			12	13.7	15	1511 (59.5)	T2

All units are single phase
 Units can be operated at 50 or 60 Hz
 * Or equivalent breaker as per local electrical inspection authority requirements
 ** Optional thermostats not available as it exceeds current rated capacity.
 *** Ensure supply wire size adheres to applicable local and national electrical codes.

NOTES

1. Heater is functioning normally if, at rated voltage, the current draw is within 10% of the value in this table.
2. Operation at lower voltages that rated will result in reduced output and current draw.
 Actual Output (kW) = [(Supply Voltage)² ÷ (Rated Voltage)²] × Rated Unit Wattage (kW)
3. Add suffix "T" for optional built-in thermostat.
4. Add suffix "H" for high-temperature ambient storage option. High temperature storage option is not available with thermostat option. Not available on IIB models.
5. For IIB model with XCT built-in thermostat - Zones 1 & 2, Groups IIA and IIB
6. For IIC model with XTWA built-in thermostat - Zones 1 & 2, Groups IIA, IIB, IIC
7. IIC Grouping units come with **x-Max**® housing
8. Remote mounted, Defender, explosion-proof room thermostats are not suitable for IIC applications
9. Temperature code ratings: T2 - 300°C (572°F), T3 - 200°C (392°F), T4 - 135°C (275°F)

CR1 Triton™ Corrosion-Resistant Washdown Heaters

Ruffneck™ CR1 Triton™ Series is a new generation of NEMA 4X corrosion-resistant washdown heaters. The first UL listed Type 4X heater with models ranging from 3 kW to 39 kW.

IMPORTANT: Ruffneck™ CR1 heaters are suitable for non-hazardous locations only. For washdown applications use water pressure less than 70 psi.

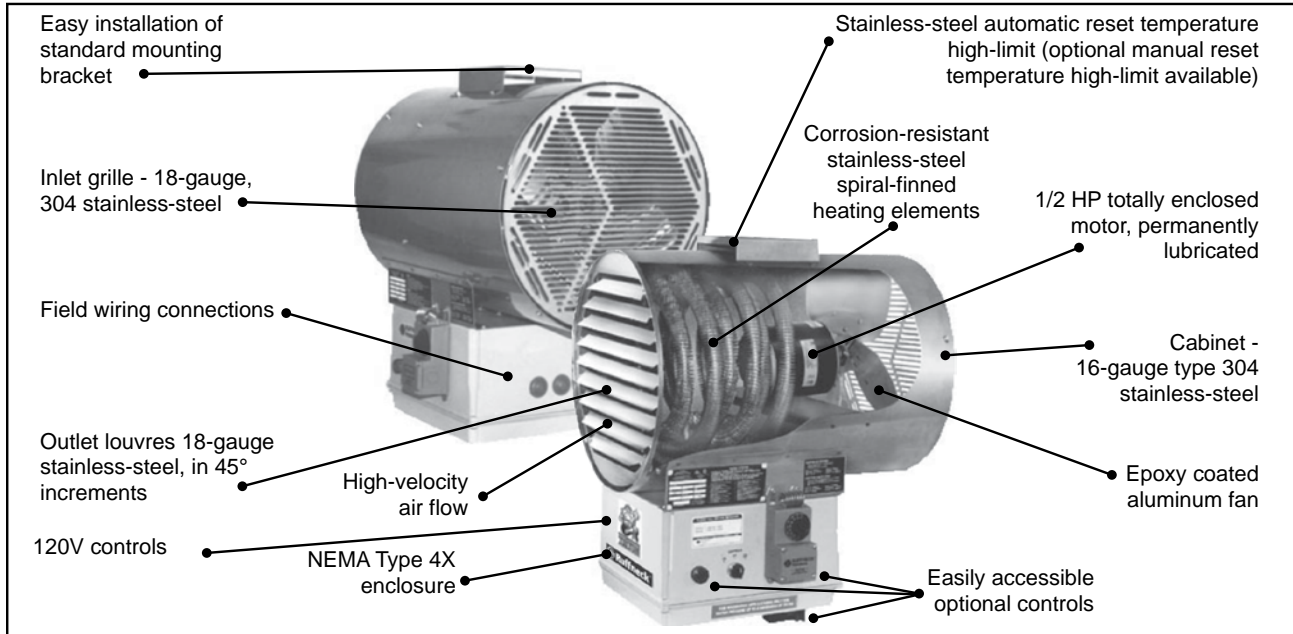

Feature

- entire heater is NEMA Type 4X
- epoxy coated fan blade
- 16-gauge stainless-steel cabinet
- custom configured stainless-steel elements
- optional built-in accessories
- stainless-steel wall/ceiling mounting kit
- 120V controls
- stainless-steel temperature high-limit

Benefit

- increased safety and protection against water penetration
- added corrosion protection
- better resistance to corrosion for longer life
- improved heat distribution and corrosion protection
- flexibility and reduced field installation costs
- flexible options for mounting heater
- better contactor pull-in reliability
- increased safety and reliability

Model Coding

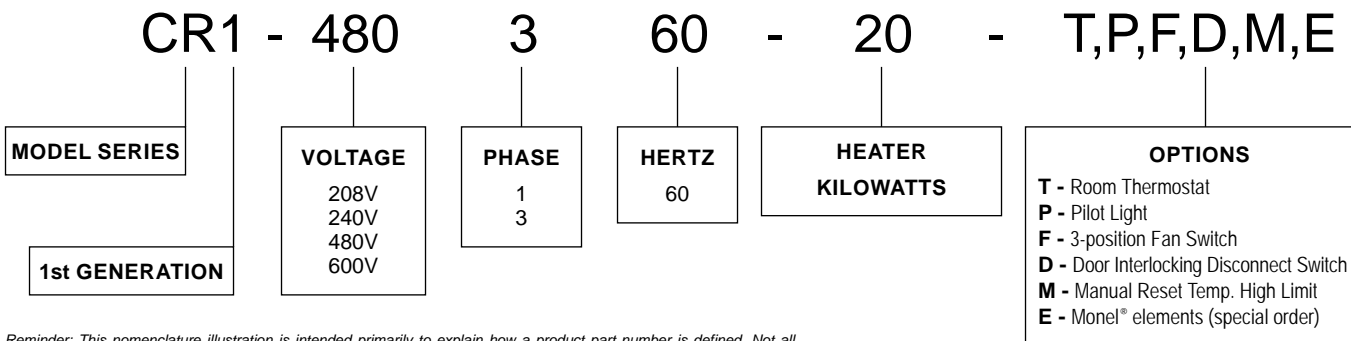

Reminder: This nomenclature illustration is intended primarily to explain how a product part number is defined. Not all voltage and/or wattage combinations are available - please consult the Performance Data chart(s) for product availability.

CR1 Triton™



CR1 Triton™ 60 Hertz Technical Data

MODEL	NOMINAL POWER (kW)	UNIT VOLTAGE (V)	PHASE	UNIT CURRENT (A)	AIR TEMPERATURE RISE		Btu/hr
					°F	°C	
CR1-208160-030	3	208	1	17.4	13.5	7.5	10250
CR1-240160-030	3	240	1	15.5	13.5	7.5	10250
CR1-208360-030	3	208	3	11.3	13.5	7.5	10250
CR1-240360-030	3	240	3	10.2	13.5	7.5	10250
CR1-480360-030	3	480	3	5.1	13.5	7.5	10250
CR1-600360-030	3	600	3	3.9	13.5	7.5	10250
CR1-208160-050	5	208	1	27.0	22.5	12.5	17050
CR1-240160-050	5	240	1	23.8	22.5	12.5	17050
CR1-208360-050	5	208	3	16.9	22.5	12.5	17050
CR1-240360-050	5	240	3	15.0	22.5	12.5	17050
CR1-480360-050	5	480	3	7.5	22.5	12.5	17050
CR1-600360-050	5	600	3	5.8	22.5	12.5	17050
CR1-208160-075	7.5	208	1	39.1	33.8	18.8	25600
CR1-240160-075	7.5	240	1	34.3	33.8	18.8	25600
CR1-208360-075	7.5	208	3	23.8	33.8	18.8	25600
CR1-240360-075	7.5	240	3	21.0	33.8	18.8	25600
CR1-480360-075	7.5	480	3	10.5	33.8	18.8	25600
CR1-600360-075	7.5	600	3	8.2	33.8	18.8	25600
CR1-240160-100	10	240	1	44.7	45.0	25.0	34100
CR1-208360-100	10	208	3	30.8	45.0	25.0	34100
CR1-240360-100	10	240	3	27.1	45.0	25.0	34100
CR1-480360-100	10	480	3	13.5	45.0	25.0	34100
CR1-600360-100	10	600	3	10.8	45.0	25.0	34100
CR1-208360-150	15	208	3	44.6	32.6	18.1	51200
CR1-240360-150	15	240	3	39.1	32.6	18.1	51200
CR1-480360-150	15	480	3	19.5	32.6	18.1	51200
CR1-600360-150	15	600	3	15.4	32.6	18.1	51200
CR1-480360-200	20	480	3	25.6	43.6	24.2	68250
CR1-600360-200	20	600	3	20.3	43.6	24.2	68250
CR1-480360-250	25	480	3	31.6	37.5	20.9	85300
CR1-600360-250	25	600	3	25.1	37.5	20.9	85300
CR1-480360-300	30	480	3	37.6	45.1	25.0	102350
CR1-600360-300	30	600	3	29.9	45.1	25.0	102350
CR1-480360-350	35	480	3	43.6	52.6	29.2	119400
CR1-600360-350	35	600	3	34.7	52.6	29.2	119400
CR1-480360-390	39	480	3	48.0	58.6	32.5	133100
CR1-600360-390	39	600	3	38.5	58.6	32.5	133100

Notes:

1. To order a heater with a built-in room thermostat add a "T" suffix to model number.
2. To order a heater with a built-in pilot light add a "P" suffix to model number.
3. To order a heater with a built-in 3-position fan switch (on, off, fan only) add an "F" to model number.
4. To order a heater with a built-in door interlocking disconnect switch add a "D" suffix to model number.
5. To order a heater with a built-in manual reset temperature high-limit add an "M" suffix to model number.
Also included is a built-in door interlocking disconnect switch to meet UL requirements.
This option replaces the automatic reset temperature high-limit.

Note: To order a heater that meets U.S. Coast Guard regulations, order built-in control option #5 above.

CR1 Triton™ Physical Dimensions

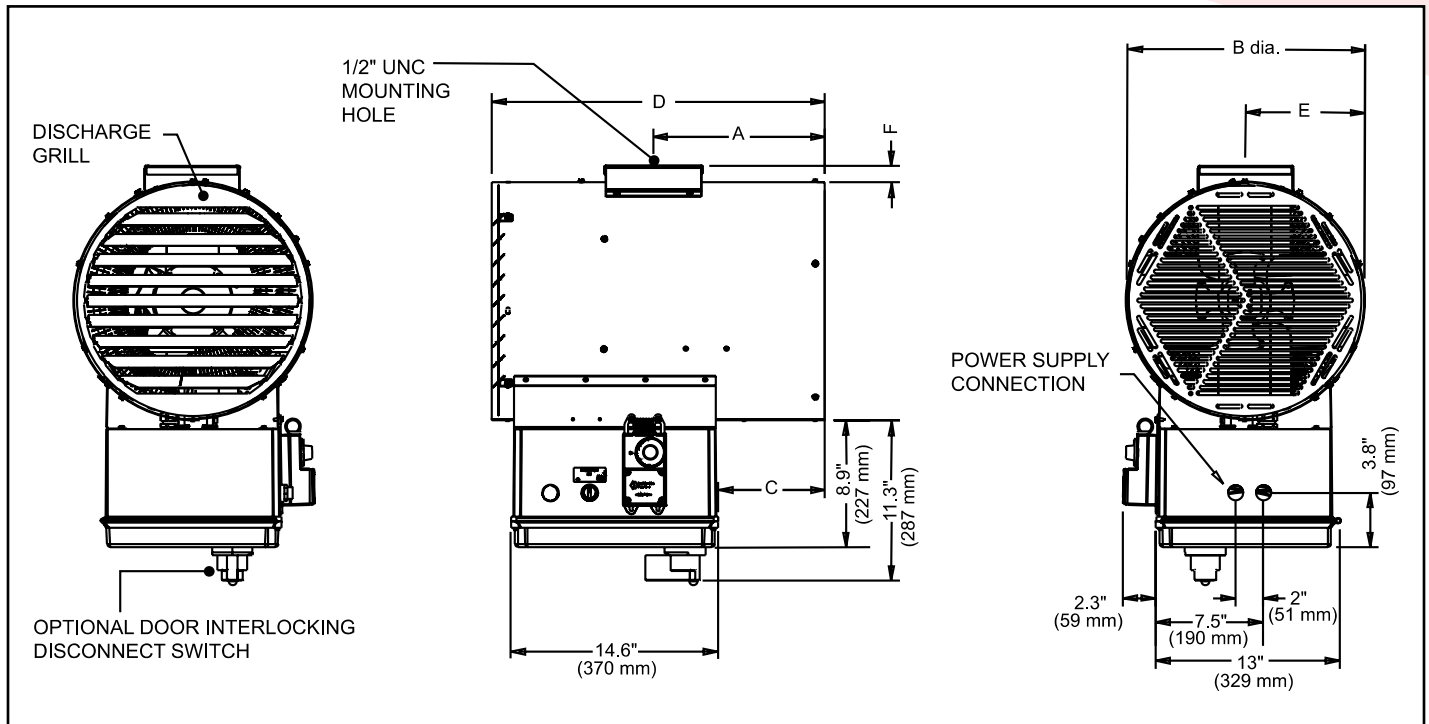

DIMENSIONS	A	B	C	D	E	F
3 to 10 kW	12.5" (318 mm)	12.8" (325 mm)	8.5" (216 mm)	24.4" (620 mm)	6.4" (162.5 mm)	0.9" (23 mm)
15 and 20 kW	12.1" (307 mm)	16.7" (425 mm)	7.5" (190 mm)	23.4" (595 mm)	8.4" (212.5 mm)	1.2" (30 mm)
25 to 39 kW	12.1" (307 mm)	20.7" (526 mm)	7.5" (190 mm)	23.4" (595 mm)	10.3" (262.5 mm)	1.3" (33 mm)

CR1 Triton™ Mounting Options

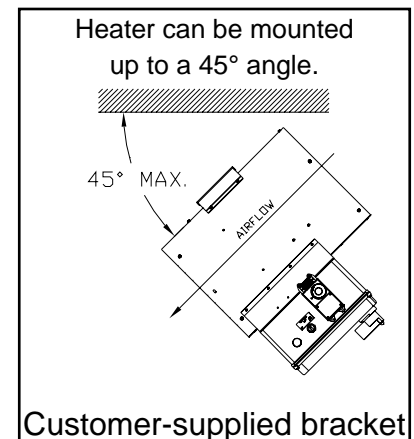
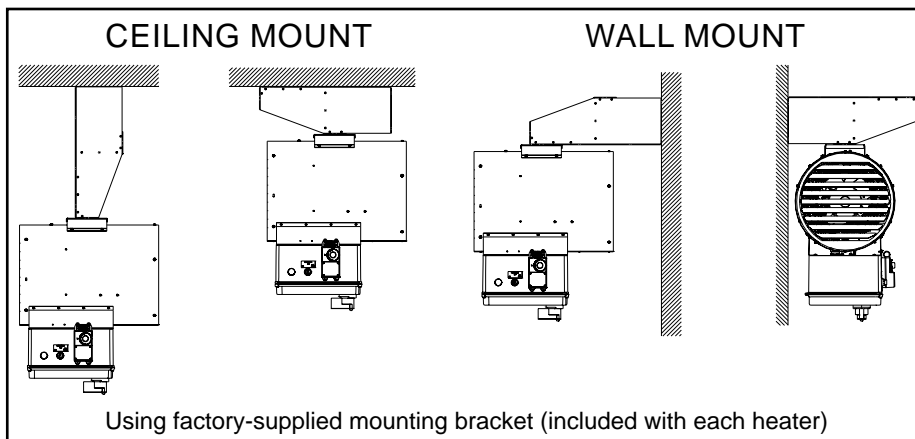

Approvals	UL listed to U.S. & Canadian safety standards. Type 4X
	Complies with U.S. Coast Guard electrical engineering regulations subchapter J (46 CFR Parts 110-113) when manual reset temperature high-limit is ordered
Enclosure	NEMA Type 4X non-metallic enclosure
Motor Type	Thermally protected, ½ HP, 1725 RPM, permanently lubricated ball bearings
Fan	Epoxy coated, aluminum blade, steel spider
Mounting Bracket	Type 304 stainless-steel universal mounting bracket Minimum 16-gauge (0.06" / 1.52 mm)
Heating Elements	Type 321 stainless-steel sheath with Type 304 stainless-steel spiral fins
Temperature High-Limit	Automatic reset, stainless-steel bulb and capillary
	Optional manual reset, stainless-steel bulb and capillary. Replaces automatic reset.
Temperature Limitations	Storage: -4°F to 140°F (-20°C to 60°C)
	Operating: -4°F to 104°F (-20°C to 40°C)
Control Circuit	120V AC
Optional Built-in Thermostat	NEMA Type 4X thermostat
Control Transformer	Multi-tap primary, 120V secondary, 50VA
Contactors	40 or 75 amp. Rated for 500,000 mechanical operations. 120V, 15VA coil
Cabinet Material	Type 304 stainless-steel, 16-gauge (0.06" / 1.52 mm) All external fasteners are stainless-steel
Inlet Grille	Type 304 stainless-steel, ¼" (6.3 mm) maximum openings Minimum 18-gauge (0.05" / 1.21 mm)
Discharge Grille	Type 304 stainless-steel. Rotatable in 45° increments Minimum 18-gauge (0.05" / 1.21 mm)

Nominal kW		3, 5, 7.5, 10	15, 20	25, 30, 35, 39
Net Weight	lbs (kg)	75.0 (34.1)	90.0 (40.9)	130 (59.1)
Shipping Weight	lbs (kg)	125.0 (56.8)	140.0 (63.6)	180 (81.8)
Fan Diameter	in (mm)	12 (305)	16 (406)	20 (508)
Air Delivery	CFM (m³/hr)	700 (1190)	1450 (2465)	2100 (3570)
Approx. Air Velocity	ft/min (m/s)	785 (4.0)	950 (4.8)	900 (4.6)
Horizontal Throw	ft (m)	22 (6.7)	35 (10.7)	44 (13.4)
Max. Mounting Height* Horizontal (to underside)	ft	8.5	11.5	12.3
	m	2.6	3.5	3.7
Max. Mounting Height* 45° decline (to underside)	ft	12.8	18.0	18.8
	m	3.9	5.5	5.7
Min. Mounting Height	ft	6.0	6.0	6.0
	m	1.8	1.8	1.8

* Maximum mounting height to ensure warm air reaches the floor.

Note:

Contact factory for suitable applications.

CR1 Triton™

CRE1 Triton™ Corrosion-Resistant Washdown Heaters

Ruffneck™ CRE1 Triton Series is a new generation of IP55 corrosion-resistant washdown heaters. The first UL listed and European compliant heater with models ranging from 2.5 kW to 40 kW.

IMPORTANT: Ruffneck™ CRE1 heaters are suitable for non-hazardous locations only. For washdown applications use water pressure less than 482 kPa only.

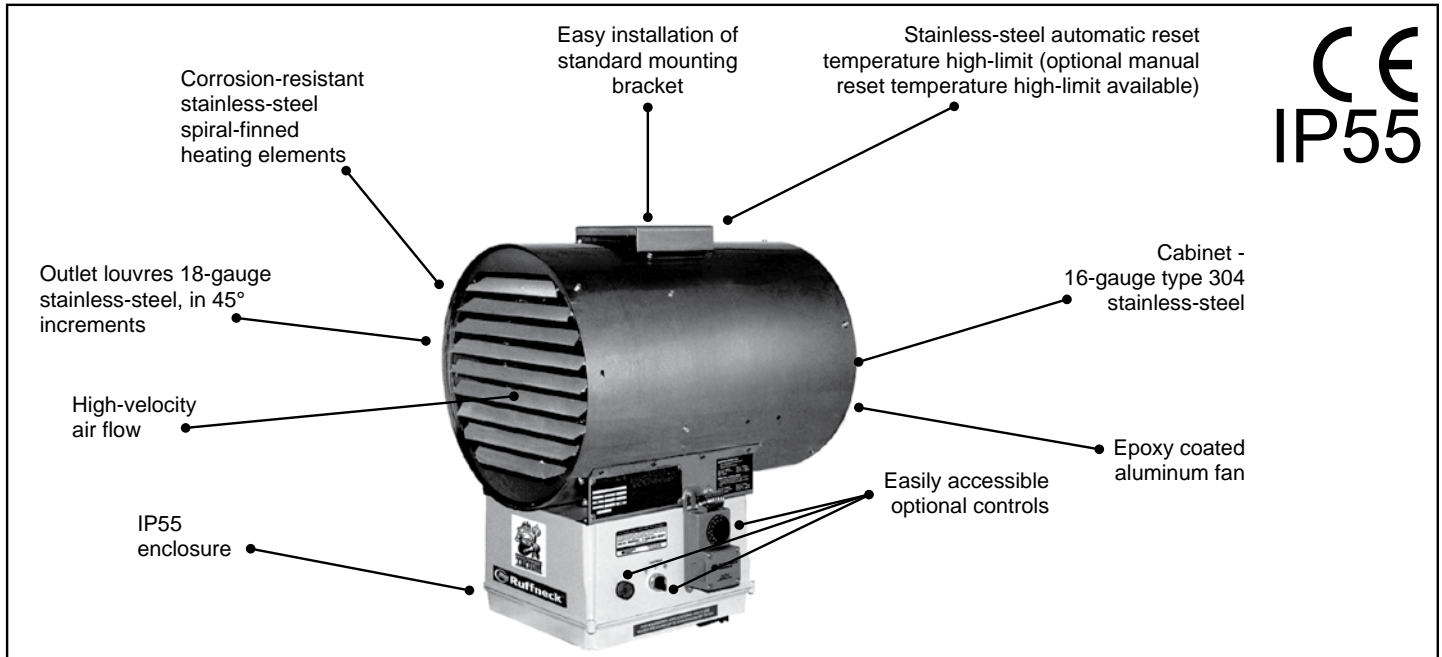

Feature

- entire heater is IP55
- epoxy coated fan blade
- 16-gauge stainless-steel cabinet
- custom configured stainless-steel elements
- optional built-in accessories
- stainless-steel wall/ceiling mounting kit
- 120V controls
- stainless-steel temperature high-limit

Benefit

- increased safety and protection against water penetration
- added corrosion protection
- better resistance to corrosion for longer life
- improved heat distribution and corrosion protection
- flexibility and reduced field installation costs
- flexible options for mounting heater
- better contactor pull-in reliability
- increased safety and reliability

Model Coding

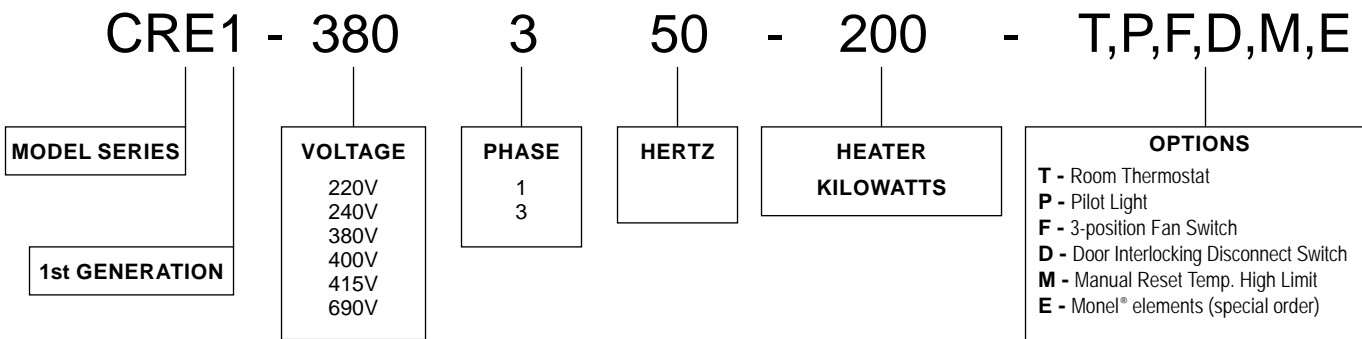

Reminder: This nomenclature illustration is intended primarily to explain how a product part number is defined. Not all voltage and/or wattage combinations are available - please consult the Performance Data chart(s) for product availability.

CRE1 Triton™

Performance Data for CR1 Triton™

MODEL	NOMINAL POWER (kW)	UNIT VOLTAGE (V)	PHASE	UNIT CURRENT (A)	CABINET SIZE
CRE1-220150-025	2.52	220	1	13.6	12
CRE1-220150-042	4.20	220	1	21.2	12
CRE1-220150-063	6.30	220	1	30.7	12
CRE1-240150-030	3.00	240	1	14.6	12
CRE1-240150-050	5.00	240	1	22.9	12
CRE1-240150-075	7.50	240	1	33.4	12
CRE1-240150-100	10.00	240	1	43.8	12
CRE1-380350-025	2.52	380	3	5.0	12
CRE1-380350-042	4.21	380	3	7.6	12
CRE1-380350-063	6.31	380	3	10.8	12
CRE1-380350-094	8.41	380	3	14.0	12
CRE1-380350-126	12.62	380	3	20.4	16
CRE1-380350-168	16.82	380	3	26.8	16
CRE1-380350-210	21.03	380	3	33.2	20
CRE1-380350-252	25.23	380	3	39.5	20
CRE1-400350-028	2.79	400	3	5.2	12
CRE1-400350-047	4.65	400	3	7.9	12
CRE1-400350-070	6.97	400	3	11.3	12
CRE1-400350-093	9.29	400	3	14.6	12
CRE1-400350-139	13.94	400	3	21.3	16
CRE1-400350-186	18.58	400	3	28.0	16
CRE1-400350-232	23.23	400	3	34.7	20
CRE1-400350-279	27.87	400	3	41.4	20
CRE1-415350-030	3.00	415	3	5.4	12
CRE1-415350-050	5.00	415	3	8.2	12
CRE1-415350-075	7.50	415	3	11.6	12
CRE1-415350-100	10.00	415	3	15.1	12
CRE1-415350-150	15.00	415	3	22.1	16
CRE1-415350-200	20.00	415	3	29.0	16
CRE1-415350-250	25.00	415	3	36.0	20
CRE1-415350-300	30.00	415	3	42.9	20
CRE1-690350-030	3.00	690	3	3.1	12
CRE1-690350-050	5.00	690	3	4.8	12
CRE1-690350-075	7.50	690	3	6.9	12
CRE1-690350100	10.00	690	3	9.0	12
CRE1-690350-150	15.0	690	3	13.2	16
CRE1-690350-200	20.00	690	3	17.3	16
CRE1-690350-250	25.00	690	3	21.5	20
CRE1-690350-300	30.00	690	3	25.7	20
CRE1-690350-350	35.00	690	3	29.9	20
CRE1-690350-400	40.00	690	3	34.1	20

Notes:

1. To order a heater with a built-in room thermostat add a "T" suffix to model number.
2. To order a heater with a built-in pilot light add a "P" suffix to model number.
3. To order a heater with a built-in 3-position fan switch (on, off, fan only) add an "F" to model number.
4. To order a heater with a built-in door interlocking disconnect switch add a "D" suffix to model number.
5. To order a heater with a built-in manual reset temperature high-limit add an "M" suffix to model number. Also included is a built-in door interlocking disconnect switch to meet CE requirements. This option replaces the automatic reset temperature high-limit.

CRE1 Triton™ Physical Dimensions

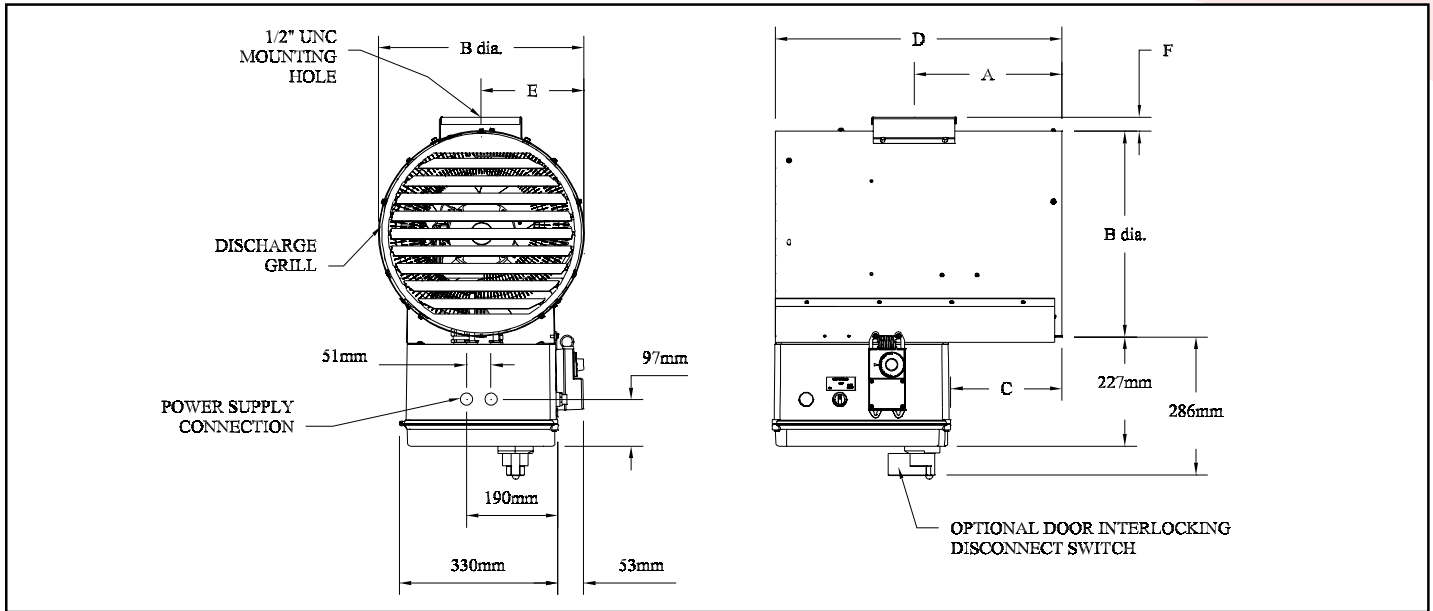

DIMENSIONS						
HEATING CAPACITY	A	B	C	D	E	F
up to 10 kW	12.5" (318 mm)	12.8" (325 mm)	8.5" (216 mm)	24.4" (620 mm)	6.4" (162.5 mm)	1" (23 mm)
15 and 20 kW	12.1" (307 mm)	16.7" (425 mm)	7.5" (190 mm)	23.4" (595 mm)	8.4" (212.5 mm)	1.1" (30 mm)
25 to 40 kW	12.1" (307 mm)	20.7" (526 mm)	7.5" (190 mm)	23.4" (595 mm)	10.3" (262.5 mm)	1.3" (33 mm)

SPECIFICATIONS				
HEATING CAPACITY	AIR DELIVERY (m ³ /hr)	AIR VELOCITY (m/s)	HORIZONTAL THROW (m)	NET WEIGHT (kg)
up to 10 kW	1190	4.0	6.7	34
15 and 20 kW	2465	4.8	10.7	41
25 to 40 kW	3570	4.6	13.4	59

CR1 Triton™ Mounting Options

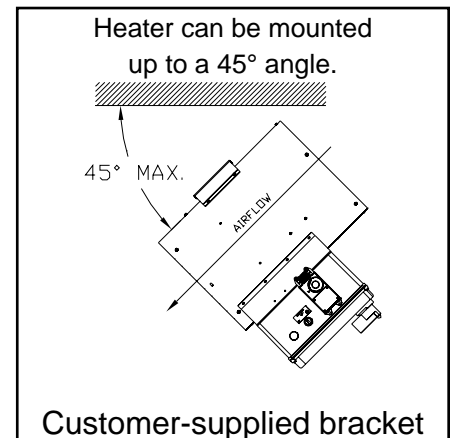
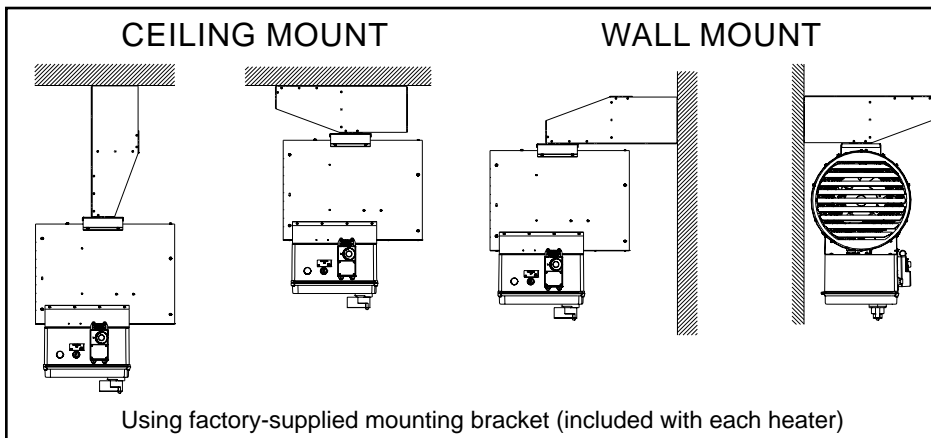

CRE1 Triton™

CRE1 Triton™ General Specifications

Approvals	CE Mark complies with European standards EN60335-1 & EN60335-2-30
Enclosure	IP55 non-metallic enclosure
Motor Type	Thermally protected, ½ HP, 1725 RPM, permanently lubricated ball bearings
Fan	Epoxy coated, aluminum blade, steel spider
Mounting Bracket	Type 304 stainless-steel, minimum 0.05" (1.21 mm) thick. Universal mounting bracket
Heating Elements	Type 321 stainless-steel sheath with Type 304 stainless-steel spiral fins
Temperature High-Limit	Automatic reset, stainless-steel bulb and capillary
	Optional manual reset, stainless-steel bulb and capillary. Replaces automatic reset
Temperature Limitations	Storage: -4°F to 140°F (-20°C to 60°C)
	Operating: -4°F to 104°F (-20°C to 40°C)
Control Circuit	120V AC
Optional Built-in Thermostat	IP55 thermostat
Control Transformer	Multi-tap primary, 120V secondary, 50VA
Contactors	40 or 75 amp. Rated for 500,000 mechanical operations. 120V, 15VA coil
Cabinet Material	Type 304 stainless-steel, 16-gauge (0.06" / 1.52 mm) All external fasteners are stainless-steel
Inlet Grille	Type 304 stainless-steel, 1/4" (6 mm) maximum openings Minimum 18-gauge (0.05" / 1.21 mm)
Discharge Grille	Type 304 stainless-steel. Rotatable in 45° increments Minimum 18-gauge (0.05" / 1.21 mm)

Nominal kW		2.5 - 10	12.62 - 20	23.23 - 40
Net Weight	kg	34.1	40.9	59.1
Shipping Weight	kg	56.8	63.6	81.8
Fan Diameter	in. (mm)	12 (305)	16 (406)	20 (508)
Air Delivery	m ³ /hr	1190	2465	3570
Approx. Air Velocity	m/s	4.0	4.8	4.6
Horizontal Throw	m	6.7	10.7	13.4
Max. Mounting Height* Horizontal (to underside)	m	2.6	3.5	3.7
Max. Mounting Height* 45° decline (to underside)	m	3.9	5.5	5.7
Min. Mounting Height	m	1.8	1.8	1.8

* Maximum mounting height to ensure warm air reaches the floor.

Note:

Contact factory for suitable applications.

CRE1 Triton™

RGE Regular Duty Air Heaters

The Ruffneck™ RGE unit heater is designed by CCI Thermal Technologies Inc. for use in regular duty industrial and commercial space heating applications. This heater features CCI Thermal Technologies Inc.'s robust design which surpasses the standards of most competitive models.



IN CANADA THESE UNITS ARE MARKETED UNDER THE CALORITECH™ BRAND NAME.

Features:

- cCSA_{US} approved for horizontal air flow
- 2 kW to 40 kW output
- 208V to 600V
- field convertible from 1 to 3 phase
- tubular heating elements
- individually adjustable air flow louvers
- permanently lubricated motors
- overheat protection
- 18-gauge steel cabinet
- epoxy painted (ASA 61 Grey)
- optional thermostats and controls
- optional wall bracket
- motors mounted outside element bundle
- ceiling mounting bracket supplied standard

Motors

- 2 kW to 10 kW heaters are standard with dual rated motors: 208/240V single phase. Where necessary, transformers are used to provide proper motor voltage.
- 15 kW to 40 kW heaters are standard with single phase full voltage rated motors.
- standard motors have permanently lubricated bearings and built-in thermal overloads.
- totally enclosed ball bearing motors are standard.
- motor RPM: 1550 unless otherwise stated.
- motor HP:
 - 2 kW to 10 kW (1/20 HP) / 15 kW to 40 kW (1/10 HP)
 - other ratings available (check with the factory)

Contactors and Transformers

- Factory installed contactors are available when required.
- Transformers are standard when primary voltage is not suitable for motor operation or contactor coil ratings.
- Standard control voltage is 240V.

Mounting Brackets

(units supplied with ceiling mounting bracket as standard)

RWB210	Wall Mounting Bracket for 2 kW - 10 kW heaters
RWB1540	Wall Mounting Bracket for 15 kW - 40 kW heaters

RGE Physical Dimensions - inches (mm)

HEATER RATING kW	A	B	C DEPTH	D HOLE DIA.	S	T	U
2 - 10	17 (432)	14 (356)	15½ (394)	½ (13)	12½ (318)	4½ (114)	4½ (114)
15 - 40	24 (610)	19½ (495)	22 (559)	¾ (16)	17½ (445)	6 (152)	6 (152)

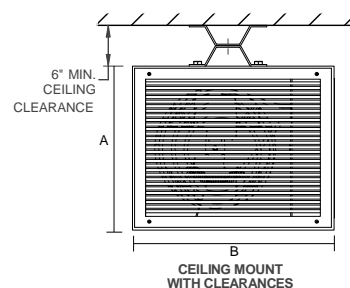
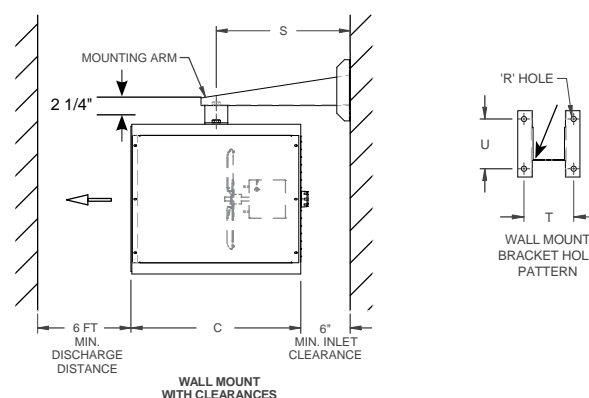

Height & Weight

kW	NORMAL MOUNTING HEIGHT ft (m)	SHIPPING WEIGHT lbs (kg)
2 - 10	6 - 8 (1.8 - 2.4)	59 (24)
15 - 40	8 - 12 (2.4 - 3.0)	104 (47)

Applications

- factories
- parking garages
- arenas
- mechanical rooms
- display areas
- warehouses
- boiler rooms
- grandstands
- shopping malls
- stores

Performance Data for RGE Regular Duty Air Heaters

kW (Btu/hr)	VOLTS	PHASE	CFM	TEMP. RISE C° (F°)	MOTOR VOLTS	CATALOG NUMBER			
						BASIC UNIT	BASIC UNIT WITH		
							CONTACTOR	THERMOSTAT (1-phase only)	CONTACTOR & THERMOSTAT
2 (6824)	208	1 or 3	460	8 (14)	208 / 240	RGE022	RGE022C	RGE022T	RGE022CT
	240	1 or 3	460	8 (14)	208 / 240	RGE023	RGE023C	RGE023T	RGE023CT
3 (10236)	208	1 or 3	465	12 (21)	208 / 240	RGE032	RGE032C	RGE032T	RGE032CT
	240	1 or 3	465	12 (21)	208 / 240	RGE033	RGE033C	RGE033T	RGE033CT
	600	1 or 3	465	12 (21)	208 / 240	RGE038	RGE038C	RGE038T	RGE038CT
4 (13648)	208	1 or 3	475	16 (28)	208 / 240	RGE042	RGE042C	RGE042T	RGE042CT
	240	1 or 3	475	16 (28)	208 / 240	RGE043	RGE043C	RGE043T	RGE043CT
	480	1 or 3	475	16 (28)	208 / 240	RGE047	RGE047C	RGE047T	RGE047CT
	600	1 or 3	475	16 (28)	208 / 240	RGE048	RGE048C	RGE048T	RGE048CT
5 (17060)	208	1 or 3	480	22 (40)	208 / 240	RGE052	RGE052C	RGE052T	RGE052CT
	240	1 or 3	480	22 (40)	208 / 240	RGE053	RGE053C	RGE053T	RGE053CT
	480	1 or 3	480	22 (40)	208 / 240	RGE057	RGE057C	RGE057T	RGE057CT
	600	1 or 3	480	22 (40)	208 / 240	RGE058	RGE058C	RGE058T	RGE058CT
7.5 (25590)	208	1 or 3	590	24 (43)	208 / 240	RGE072	RGE072C	—	RGE072CT
	240	1 or 3	590	24 (43)	208 / 240	RGE073	RGE073C	—	RGE073CT
	480	1 or 3	590	24 (43)	208 / 240	RGE077	RGE077C	—	RGE077CT
	600	1 or 3	590	24 (43)	208 / 240	RGE078	RGE078C	—	RGE078CT
10 (34120)	208	1 or 3	760	25 (45)	208 / 240	RGE102	RGE102C	—	RGE102CT
	240	1 or 3	760	25 (45)	208 / 240	RGE103	RGE103C	—	RGE103CT
	480	1 or 3	760	25 (45)	208 / 240	RGE107	RGE107C	—	RGE107CT
	600	1 or 3	760	25 (45)	208 / 240	RGE108	RGE108C	—	RGE108CT
15 (51180)	208	3	1040	28 (50)	208	RGE152	RGE152C	—	RGE152CT
	240	3	1040	28 (50)	240	RGE153	RGE153C	—	RGE153CT
	480	1 or 3	1040	28 (50)	480	RGE157	RGE157C	—	RGE157CT
	600	1 or 3	1040	28 (50)	600	RGE158	RGE158C	—	RGE158CT
20 (68240)	208	3	1260	31 (55)	208	RGE202	RGE202C	—	RGE202CT
	240	3	1260	31 (55)	240	RGE203	RGE203C	—	RGE203CT
	480	1 or 3	1260	31 (55)	480	RGE207	RGE207C	—	RGE207CT
	600	1 or 3	1260	31 (55)	600	RGE208	RGE208C	—	RGE208CT
25 (85300)	480	3	1500	34 (61)	480	RGE257	RGE257C	—	RGE257CT
	600	3	1500	34 (61)	600	RGE258	RGE258C	—	RGE258CT
30 (102360)	480	3	1500	39 (70)	480	RGE307	RGE307C	—	RGE307CT
	600	3	1500	39 (70)	600	RGE308	RGE308C	—	RGE308CT
40 (136480)	480	3	1500	44 (80)	480	RGE407	RGE407C	—	RGE407CT
	600	3	1500	44 (80)	600	RGE408	RGE408C	—	RGE408CT

Accessories for Field Installation:

- FAT 8 field installed built-in thermostat kit 41°F to 100°F (5°C to 38°C)
- RWB210 wall mount bracket (2 kW to 10 kW)
- RWB1540 wall mount bracket (15 kW to 40 kW)
- remote thermostats available

To Order Specify:

Catalog Number, Voltage, Phase, Kilowatts, Optional Features and Accessories

Optional Factory Installed Features:

- built-in thermostat 41°F to 100°F (5°C to 38°C)
- fused control circuit
- manual reset high limit
- "fan only" switch
- low voltage relay for remote 24V thermostat
- epoxy painted fan blade and motor
- special wattages and voltages
- special control voltages (240V is standard)
- available in special finishes.

Regular Duty Electric Unit Heaters Type RGE Specification Sheet

1.0 Scope

1.1 Regular duty electric unit heaters, Ruffneck™ model RGE, as manufactured by CCI Thermal Technologies Inc. complete with ratings and features as specified below.

2.0 Ratings

2.1 The heater(s) shall be of the regular duty, forced air type, catalog number _____, rated _____V, _____ phase, _____ Hz, _____ kW.

2.2 The heater(s) shall be _CCSA_{US} certified to the following standards:

- CSA C22.2 No. 46-M1988 Electric Air Heaters
- UL Standard 1025 Electric Air Heaters

3.0 Standard Features

3.1 Units rated 2 kW to 10 kW shall use stainless-steel tubular heating elements; units rated 15 kW to 40 kW shall use finned tubular heating elements to transfer the heat.

3.2 Units shall be field convertible from 1 phase to 3 phase.

3.3 Heater cabinets shall be 18-gauge steel and painted with ASA 61 grey epoxy for rust protection.

3.4 Heaters shall have individually adjustable, aluminum louvres to direct the outlet airflow.

3.5 Motors shall be mounted outside of the element bundle and be of the totally enclosed type with permanently lubricated ball bearings and built-in thermal overloads with ratings as follows:

- For 2 kW to 10 kW heaters, motors shall be 1/20 HP, 1550 RPM dual rated 208/240V single phase. For heater voltages above 240V a transformer shall be included to provide the proper motor voltage.
- For 15 kW to 40 kW heaters, 1/10 HP, 1550 RPM, full voltage rated, single phase.

3.6 Standard control voltage shall be 240V. A built-in transformer shall be supplied when the primary voltage differs from the control voltage.

3.7 The heater shall be supplied with built-in overheat protection of the auto-reset, bimetal type.

3.8 The heater shall be supplied with ceiling mount brackets as standard.

3.9 All heaters shall have a ½" x ¾" (12.7 mm x 19.05 mm) multiple conduit knockout. Heaters rated 15 kW to 40 kW shall be provided with an additional 1" x 1¼" (25.4 mm x 31.75 mm) multiple conduit knockout.

3.10 Approximate heater dimensions and weights shall be as follows:

kW Rating	Height	Width	Depth	Weight
2-10 kW	14" (356 mm)	17" (432 mm)	15½" (394 mm)	59 lbs (24 kg)
15-40 kW	19½" (495 mm)	24" (610 mm)	22" (559 mm)	104 lbs (47 kg)

4.0 Optional Factory Installed Features

4.1 The following factory installed optional features (indicated with a check) shall be included:

- | | |
|--|---|
| <input type="checkbox"/> Built-in bulb and capillary thermostat, 41°F to 100°F (5°C to 38°C) | <input type="checkbox"/> Manual reset high limit |
| <input type="checkbox"/> Definite purpose magnetic contactor | <input type="checkbox"/> "Fan-only" switch |
| <input type="checkbox"/> Fused control circuit | <input type="checkbox"/> Low voltage relay for remote 24V control |
| | <input type="checkbox"/> Epoxy painted fan blade and motor |

5.0 Accessories for Field Installation

5.1 The following accessories (indicated with a check) shall be included with the unit for field installation:

- FAT 8 field installed built-in thermostat kit, 41°F to 100°F (5°C to 38°C)
- Wall mount bracket: RWB210 for units rated 2 kW to 10 kW; RWB1540 for units rated 15 kW to 40 kW.

RGX Heavy Duty Air Heaters

The Ruffneck™ RGX unit heater was designed by CCI Thermal Technologies Inc. specifically for heavy duty use in industrial environments. This heater will reduce the downtime and maintenance costs usually experienced with heaters of standard design.

Applications



**IN CANADA
THESE UNITS ARE
MARKETED UNDER
THE CALORITECH™
BRAND NAME.**

- mine shafts
- pulp & paper mills
- hoist houses
- welding shops
- maintenance shops
- sewage treatment plants
- chemical plants
- repair shops
- wash down areas
- weigh scale pits
- elevator shafts
- high humidity areas
- crane cabs

Features:

- cCSA_{US} approved for horizontal and vertical air flow
- automatic reset high limit
- 15, 20, 25, 30, 40, 50 kW units (optional 10 kW unit)
- 40 and 50 kW units incorporate split loads (50%) for remotely controlled energy management systems
- factory installed transformers, contactors, and thermostats where specified
- individually adjustable air flow louvres
- factory balanced aluminum fan blade
- fan delay in "ON" and "OFF" cycles
- full sized control panel with hinged removable door, constructed to NEMA 12 standards
- "Fan Only" terminals for connection to remote switch
- 14-gauge steel cabinet
- epoxy painted (ASA 61 Grey) for superior resistance to corrosion
- 1/3 HP motor with sealed ball bearings and totally enclosed construction
- ceiling mounting bracket supplied
- motor mounted outside of the element bundle thereby eliminating premature failure due to overheating and providing easy access for motor maintenance

- elements are robust KX finned tubular sheathed type with epoxy sealed terminals to eliminate contamination from moisture and airborne impurities

Mounting Configurations

Horizontal Air Flow Wall Mount

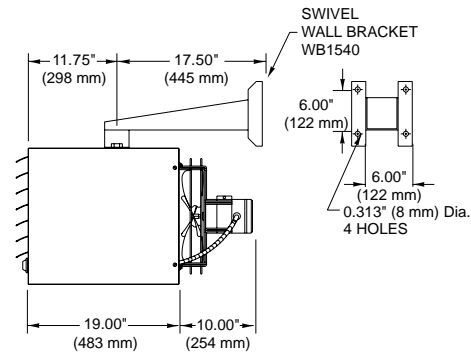

Horizontal Air Flow Ceiling Mount

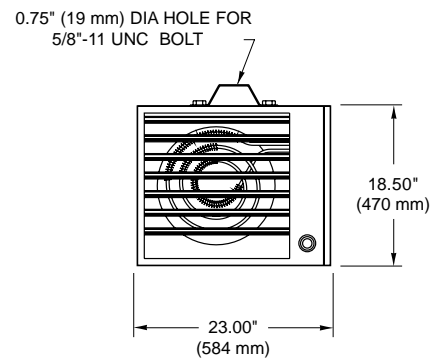
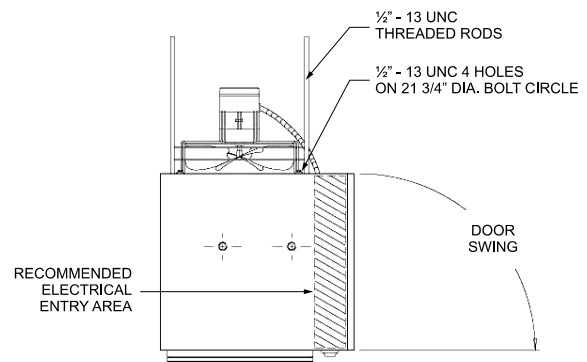

Figure 2 – Horizontal Air Flow Ceiling Mount

Vertical Air Flow



Performance Data for RGX Heavy Duty Air Heaters

kW (Btu/hr)	VOLTS	PHASE	CFM	TEMP. RISE C° (F°)	CATALOG NUMBER			NET WEIGHT
					WITHOUT CONTACTOR	WITH CONTACTOR	WITH T'STAT & CONTACTOR	
15 (51180)	208	3	1800	14 (25)	RGX152	RGX152C	RGX152CT	105 lbs 47.6 kg
	240	3	1800	14 (25)	RGX153	RGX153C	RGX153CT	
	480	3	1800	14 (25)	RGX157	RGX157C	RGX157CT	
	600	3	1800	14 (25)	RGX158	RGX158C	RGX158CT	
20 (68240)	208	3	1800	19 (34)	RGX202*	RGX202C*	RGX202CT*	105 lbs 47.6 kg
	240	3	1800	19 (34)	RGX203	RGX203C	RGX203CT	
	480	3	1800	19 (34)	RGX207	RGX207C	RGX207CT	
	600	3	1800	19 (34)	RGX208	RGX208C	RGX208CT	
25 (85300)	208	3	1800	24 (41)	RGX252*	RGX252C*	RGX252CT*	105 lbs 47.6 kg
	240	3	1800	24 (41)	RGX253*	RGX253C*	RGX253CT*	
	480	3	1800	24 (41)	RGX257	RGX257C	RGX257CT	
	600	3	1800	24 (41)	RGX258	RGX258C	RGX258CT	
30 (102360)	480	3	2100	24 (41)	RGX307	RGX307C	RGX307CT	105 lbs 47.6 kg
	600	3	2100	24 (41)	RGX308	RGX308C	RGX308CT	
40 (136500)	480	3	2100	32 (58)	RGX407	RGX407C	RGX407CT	125 lbs 56.7 kg
	600	3	2100	32 (58)	RGX408	RGX408C	RGX408CT	
50 (170600)	480	3	2100	40 (72)	RGX507	RGX507C	RGX507CT	125 lbs 56.7 kg
	600	3	2100	40 (72)	RGX508	RGX508C	RGX508CT	

* These units exceed 48 amps, and may require special split load feature.

Notes:

1. Motor voltage and phase is same as heater supply.
2. Standard control voltage is 240V. A control transformer is included where required. Other control voltages are available. (Check with factory.)
3. 15, 20, 25, 30 kW units are pre-wired as one circuit. The split load feature (50%) is available as an option.
4. 40 and 50 kW units are pre-wired for split load (50%) control by customer unless specified otherwise.
5. All motors are 1/3 HP, totally enclosed ball bearing type, permanently lubricated, thermally protected.

Optional Factory Installed Features:

- built-in thermostat 41°F to 100°F (5°C to 38°C)
- disconnect switch with door interlock
- HRC main load fuses
- fused control circuit
- manual reset high limit
- "Fan Only" switch
- low voltage relay for remote 24V thermostat
- epoxy painted fan blade and motor
- special wattages and voltages
- special control voltages (240V is standard)
- available in special finishes
- split load feature 15, 20, 25, 30 kW units
- alloy elements with brazed alloy fins
- nickel plated elements
- stainless-steel cabinet
- EEMAC 4 construction

Accessories for Field Installation:

- FAT 8A field installed built-in thermostat kit 41°F to 100°F (5°C to 38°C)
- RWB210 wall mount bracket (2 to 10 kW)
- RWB1540 wall mount bracket (15 to 40 kW)
- air diffuser (vertical air flow)
- "Fan Only" switch and cover plate
- remote thermostats available

To Order Specify:

Catalog Number, Voltage, Phase, Kilowatts, Optional Features and Accessories

RGX Heavy Duty

Heavy Duty Electric Unit Heaters Type RGX Specification Sheet

1.0 Scope

- 1.1 Heavy duty electric unit heaters, Ruffneck™ model RGX, as manufactured by CCI Thermal Technologies Inc. complete with ratings and features as specified below.

2.0 Ratings

- 2.1 The heater(s) shall be of the heavy duty, forced air type, catalog number _____, rated _____ V, _____ phase, _____ Hz, _____ kW.
- 2.2 The heater(s) shall be CCSAUS certified to CSA Standard C22.2 No. 46-M1988 Electric Air Heaters, and UL Standard 1025 Electric Air Heaters.

3.0 Standard Features

- 3.1 Heavy duty unit heaters shall be approved for horizontal and vertical airflow.
- 3.2 Heaters shall use Caloritech™ type KX finned tubular elements to transfer the heat. Elements shall have epoxy sealed terminals to eliminate the possibility of contamination from moisture and airborne impurities.
- 3.3 Heaters rated 40 kW and 50 kW shall be provided (as standard) with 50% split loads for remotely controlled energy management systems. Split load feature shall be provided if specified on 15 kW to 30 kW units.
- 3.4 Heater cabinets shall be 14-gauge steel, painted with ASA 61 grey epoxy for superior corrosion protection. The cabinet shall also incorporate a full sized control panel with hinged removable door, constructed to NEMA 12 standards.
- 3.5 The heater shall have seven (7) individually adjustable, extruded aluminum louvres to direct the outlet airflow.
- 3.6 Motors shall be of the totally enclosed type with permanently lubricated ball bearings and built-in thermal overload, rated 1/3 HP, 1725 RPM with the voltage rating the same as the heater. The motor shall be mounted outside of the element bundle to eliminate premature failure due to overheating and to provide easy access for maintenance.
- 3.7 A factory balanced aluminum fan blade shall provide the airflow through the heater.
- 3.8 The standard control voltage shall be 240V. A built in transformer shall be supplied when required.
- 3.9 Heavy duty unit heaters shall incorporate a fan delay in the "On" and "Off" cycles. "Fan-only" terminals for connection to a remote switch shall also be supplied as standard.
- 3.10 The heater shall be supplied with built-in overheat protection of the auto-reset, bimetal type.
- 3.11 The heater shall be equipped with ceiling mount brackets as standard.
- 3.12 Approximate heater dimensions shall be 18½" (470 mm) high x 23" (584 mm) wide x 30" (762 mm) long.
- 3.13 Shipping weight shall be 105 lbs (48 kg) for 15 kW to 30 kW and 125 lbs (57 kg) for 40 kW & 50 kW units.

4.0 Optional Factory Installed Features

- 4.1 The following factory installed optional features (indicated with a check) shall be included:
- | | |
|--|--|
| <input type="checkbox"/> Built-in bulb and capillary thermostat, 41°F to 100°F (5°C to 38°C) | <input type="checkbox"/> Low voltage relay for remote 24V thermostat |
| <input type="checkbox"/> Disconnect switch with door interlock | <input type="checkbox"/> Epoxy painted fan blade and motor |
| <input type="checkbox"/> HRC main load fuses | <input type="checkbox"/> Split load feature, 15 kW to 30 kW units |
| <input type="checkbox"/> Manual reset high limit | <input type="checkbox"/> Nickel plated elements |
| <input type="checkbox"/> "Fan-only" switch | <input type="checkbox"/> Stainless-steel cabinet |

5.0 Accessories for Field Installation

- 5.1 The following accessories (indicated with a check) shall be included with the unit for field installation:
- | | |
|---|--|
| <input type="checkbox"/> FAT 8A field installed built-in thermostat kit 41°F to 100°F (5°C to 38°C) | <input type="checkbox"/> Air diffuser for vertical air flow. |
| <input type="checkbox"/> Wall mount bracket: model RWB1540. | |

Explosion-Proof Duct Heaters - Type RXDF



Ruffneck™ type RXDF duct heaters are designed for heating air or gases which contain potentially explosive substances. RXDF heaters feature the unique Ruffneck™ approach to explosion-proof electric heater design which embodies safety, reliability and economy.

The RXDF is a factory pre-wired explosion-proof duct heater. Standard models are available in three duct sizes, with either a single or double bank of heating modules. RXDF heaters are available as standard units with T2D, T3A or T3B hazardous area temperature codes.

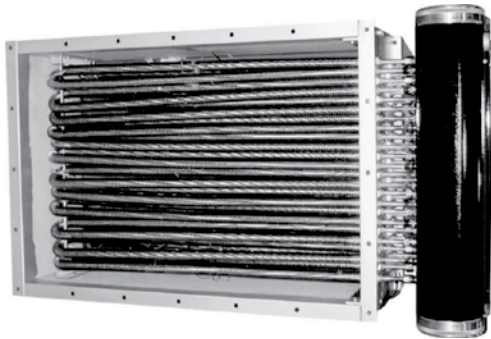

IN CANADA THESE UNITS ARE
MARKETED UNDER THE CALORITECH™ BRAND NAME.
REFER TO CALORITECH™ CATALOGUE SECTION C.

Construction

The RXDF explosion-proof duct heater utilizes heavy walled carbon steel finned tubular elements with nickel plated finish to provide safe, efficient, low temperature heat transfer. Standard units have a painted steel duct with mounting holes provided for attachment to the duct section.

RXDF heaters feature the unique copper free aluminum extruded x-Max® terminal housing (U.S. Pat. No. 5,798,910, CDN. Pat. No. 2,212,500). A track and trolley system and threaded covers at each end allow easy access to wiring terminal connections. Units are approved for mounting in a horizontal duct section.

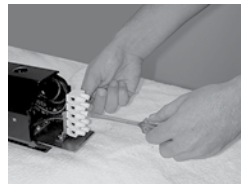

Wattage

Units are available in wattages up to 50 kW.

Designed for Application in Hazardous Environments, such as:

- oil refineries
- coal mines
- pulp and paper mills
- petrochemical plants
- grain elevators
- sewage treatment plants

Control Panels

For information on control panels please contact the factory.

Thermostats

CCI Thermal Technologies Inc. offers a wide variety of explosion proof thermostats to suit most every need. All model RXDF heaters are available with remote externally adjustable thermostats which are field convertible to tamper-proof.

Heater Selection

Standard Ruffneck™ RXDF duct heaters may be operated in hazardous areas where the ambient temperature does not exceed 104°F (40°C) and the maximum heater surface temperature does not exceed the temperature code rating. Use the following steps for heater selection.

1. Determine the class, divisions, and group required.
2. **Determine temperature code rating.** Standard heaters are available for T2D, T3A or T3B areas.
3. **Determine kW rating.** Standard heaters are available up to 50 kW.
4. **Determine duct size.** Three standard sizes are available and transition sections can be provided for other duct sizes.
5. **Verify air flow requirements.** The table on the following page lists the minimum air flow (SCFM) required for each heater type.
6. Verify temperature rise using the following formula:

C° Temperature Rise	F° Temperature Rise
$C^{\circ} \text{ temp. rise} = \frac{\text{kW} \times 1667}{\text{SCFM}}$	$F^{\circ} \text{ temp. rise} = \frac{\text{kW} \times 3000}{\text{SCFM}}$

7. **Determine power supply voltage and phase.** Standard units are available in 208, 240, 480 or 600V, 3-phase. Optional 1-phase units also available.

RXDF

Standard Heater Features:

- T2D, T3A or T3B temperature code
- painted steel duct section
- differential pressure switch
- factory installed high limit sensing thermocouples
- extra heavy wall 0.095" (2 mm) finned tubular heating elements with nickel plated finish.

Optional Features:

- transition sections
- stainless-steel duct section
- special temperature code
- outlet air thermostat
- outlet air thermocouple

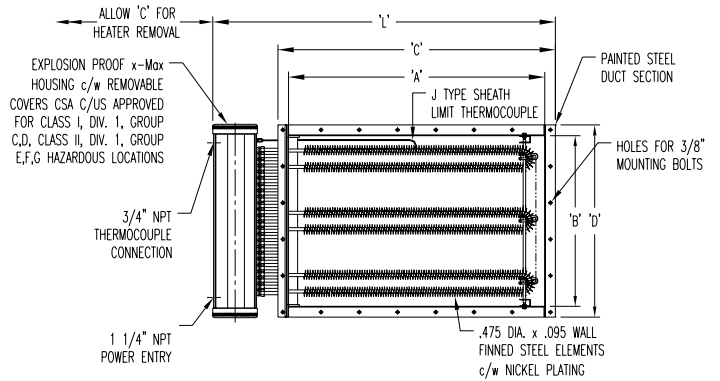
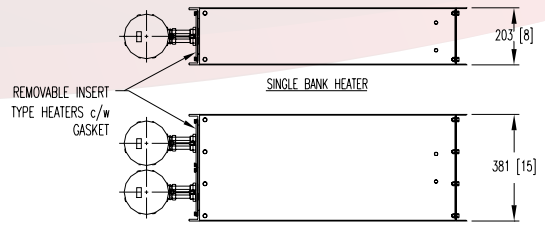

RXDF Physical Dimensions in inches (mm)

DUCT SIZE	A	B	C	D	L
24" x 12" (610 x 305)	24 (610)	12 (305)	27 (686)	15 (381)	36½ (927)
30" x 18" (762 x 457)	30 (762)	18 (457)	33 (838)	21 (533)	42½ (1080)
36" x 24" (914 x 610)	36 (914)	24 (610)	39 (991)	27 (686)	48½ (1232)

Performance Data For RXDF Explosion-Proof Duct Heater

DUCT SIZE A x B	NUMBER OF HEATING BANKS	kW	AVAILABLE VOLTAGES		HIGH TEMP. RISE UNITS - T2D 419°F (215°C)							LOW TEMP. RISE UNITS - T3A 356°F (180°C) or T3B 329°F (165°C)						NET WEIGHT lbs (kg)	
					Class I, Div. 1 & 2, Groups C & D							Class I, Div. 1 & 2, Groups C & D Class II, Div. 1 & 2, Groups E & F Class II, Div. 1 & 2, Group G (T3B units only)							
					208 V 3 φ	240 V 3 φ	480 V 3 φ	600 V 3 φ	TEMP. CODE	CATALOG NO.	MAX. TEMP. RISE		MIN. AIR FLOW SCFM	TEMP. CODE	CATALOG NO.	MAX. TEMP. RISE			MIN. AIR FLOW SCFM
											F°	C°				F°	C°		
24" x 12" (610 x 305 mm)	1	2.5	✓	✓	✓	✓	T2D	RXDF1-24x12-025T2D	13.9	7.7	540	T3B	RXDF1-24x12-025T3B	6.8	3.8	1107	90 (41)		
		3.75	✓	✓	✓	✓	T2D	RXDF1-24x12-038T2D	20.8	11.6	540	T3B	RXDF1-24x12-038T3B	8.4	4.7	1334			
		5	✓	✓	✓	✓	T2D	RXDF1-24x12-050T2D	19.7	11.0	761	T3B	RXDF1-24x12-050T3B	9.6	5.3	1562			
		7.5	✓	✓	✓	✓	T2D	RXDF1-24x12-075T2D	18.0	10.0	1247	T3A	RXDF1-24x12-075T3A	13.0	7.2	1728			
	2	5	✓	✓	✓	✓	T2D	RXDF2-24x12-050T2D	27.8	15.4	540	T3B	RXDF2-24x12-050T3B	13.6	7.5	1107			
		7.5	✓	✓	✓	✓	T2D	RXDF2-24x12-075T2D	41.7	23.2	540	T3B	RXDF2-24x12-075T3B	16.9	9.4	1334			
30" x 18" (762 x 457 mm)	1	10	✓	✓	✓	✓	T2D	RXDF2-24x12-100T2D	39.4	21.9	761	T3B	RXDF2-24x12-100T3B	19.2	10.7	1562	160 (73)		
		15	✓	✓	✓	✓	T2D	RXDF2-24x12-150T2D	36.1	20.1	1247	T3A	RXDF2-24x12-150T3A	26.0	14.5	1728			
		5	✓	✓	✓	✓	T2D	RXDF1-30x18-050T2D	14.8	8.2	1013	T3B	RXDF1-30x18-050T3B	7.1	4.0	2109			
		6.25	✓	✓	✓	✓	T2D	RXDF1-30x18-063T2D	18.5	10.3	1013	T3B	RXDF1-30x18-063T3B	8.0	4.5	2331			
		7.5	✓	✓	✓	✓	T2D	RXDF1-30x18-075T2D	22.2	12.3	1013	T3B	RXDF1-30x18-075T3B	8.8	4.9	2553			
	2	10	✓	✓	✓	✓	T2D	RXDF1-30x18-100T2D	19.5	10.8	1538	T3B	RXDF1-30x18-100T3B	10.0	5.6	2991	135 (61)		
		12.5	✓	✓	✓	✓	T2D	RXDF1-30x18-125T2D	18.9	10.5	1989	T3B	RXDF1-30x18-125T3B	10.9	6.1	3434			
		15	✓	✓	✓	✓	T2D	RXDF1-30x18-150T2D	18.4	10.2	2440	T3A	RXDF1-30x18-150T3A	13.5	7.5	3333			
		20	✓	✓	✓	✓	T2D	RXDF2-30x18-100T2D	29.6	16.5	1013	T3B	RXDF2-30x18-100T3B	14.2	7.9	2109			
		12.5	✓	✓	✓	✓	T2D	RXDF2-30x18-125T2D	37.0	20.6	1013	T3B	RXDF2-30x18-125T3B	16.1	8.9	2331			
36" x 24" (914 x 610 mm)	1	15	✓	✓	✓	✓	T2D	RXDF2-30x18-150T2D	44.5	24.7	1013	T3B	RXDF2-30x18-150T3B	17.6	9.8	2553	250 (114)		
		20	✓	✓	✓	✓	T2D	RXDF2-30x18-200T2D	39.0	21.7	1538	T3B	RXDF2-30x18-200T3B	20.1	11.1	2991			
		25	✓	✓	✓	✓	T2D	RXDF2-30x18-250T2D	37.7	21.0	1989	T3B	RXDF2-30x18-250T3B	21.8	12.1	3434			
		30	✓	✓	✓	✓	T2D	RXDF2-30x18-300T2D	36.9	20.5	2440	T3A	RXDF2-30x18-300T3A	27.0	15.0	3333			
		7.5	✓	✓	✓	✓	T2D	RXDF1-36x24-075T2D	13.9	7.7	1620	T3B	RXDF1-36x24-075T3B	6.9	3.8	3256			
	2	10	✓	✓	✓	✓	T2D	RXDF1-36x24-100T2D	18.5	10.3	1620	T3B	RXDF1-36x24-100T3B	8.1	4.5	3690	180 (82)		
		12.5	✓	✓	✓	✓	T2D	RXDF1-36x24-125T2D	23.2	12.9	1620	T3B	RXDF1-36x24-125T3B	9.1	5.1	4125			
		15	✓	✓	✓	✓	T2D	RXDF1-36x24-150T2D	20.2	12.9	2230	T3B	RXDF1-36x24-150T3B	9.9	5.5	4559			
		20	✓	✓	✓	✓	T2D	RXDF1-36x24-200T2D	19.3	10.7	3115	T3B	RXDF1-36x24-200T3B	11.1	6.1	5428			
		25	—	✓	✓	✓	T2D	RXDF1-36x24-250T2D	18.8	10.4	4000	T3A	RXDF1-36x24-250T3A	13.8	7.7	5427			
2	15	✓	✓	✓	✓	T2D	RXDF2-36x24-150T2D	27.8	15.4	1620	T3B	RXDF2-36x24-150T3B	13.8	7.7	3256	325 (148)			
	20	✓	✓	✓	✓	T2D	RXDF2-36x24-200T2D	37.0	20.6	1620	T3B	RXDF2-36x24-200T3B	16.3	9.0	3690				
	25	✓	✓	✓	✓	T2D	RXDF2-36x24-250T2D	46.3	25.7	1620	T3B	RXDF2-36x24-250T3B	18.2	10.1	4125				
	30	✓	✓	✓	✓	T2D	RXDF2-36x24-300T2D	40.4	22.4	2230	T3B	RXDF2-36x24-300T3B	19.7	11.0	4559				
	40	✓	✓	✓	✓	T2D	RXDF2-36x24-400T2D	38.5	21.4	3115	T3B	RXDF2-36x24-400T3B	22.1	12.3	5426				
50	—	✓	✓	✓	T2D	RXDF2-36x24-500T2D	37.5	20.8	4000	T3A	RXDF2-36x24-500T3A	27.6	15.4	5427					

To Order: Specify quantity, catalog no., voltage and phase, wattage, hazardous location designation, temperature code, control package and optional features.

RXDF

Package #1 - Basic Unit (ON/OFF Control)

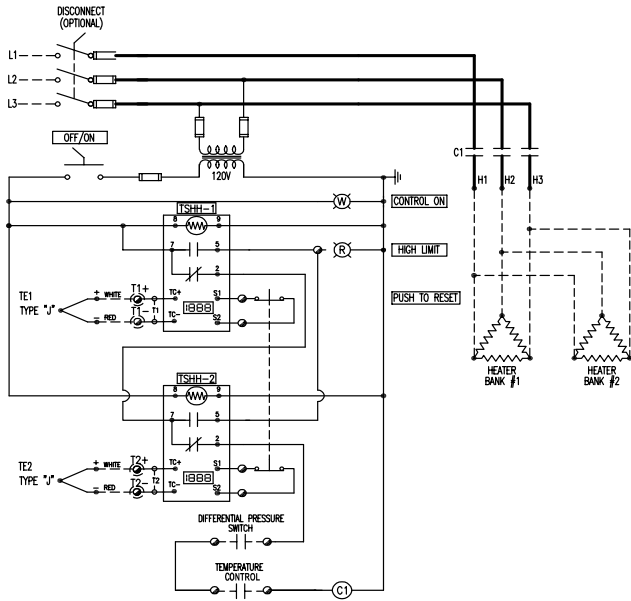

Notes:
 ONE HIGH LIMIT CONTROL PROVIDED ON SINGLE BANK HEATERS.
 TWO HIGH LIMIT CONTROLS PROVIDED ON DOUBLE BANK HEATERS.

Package #2 - Built-in Temperature Controller

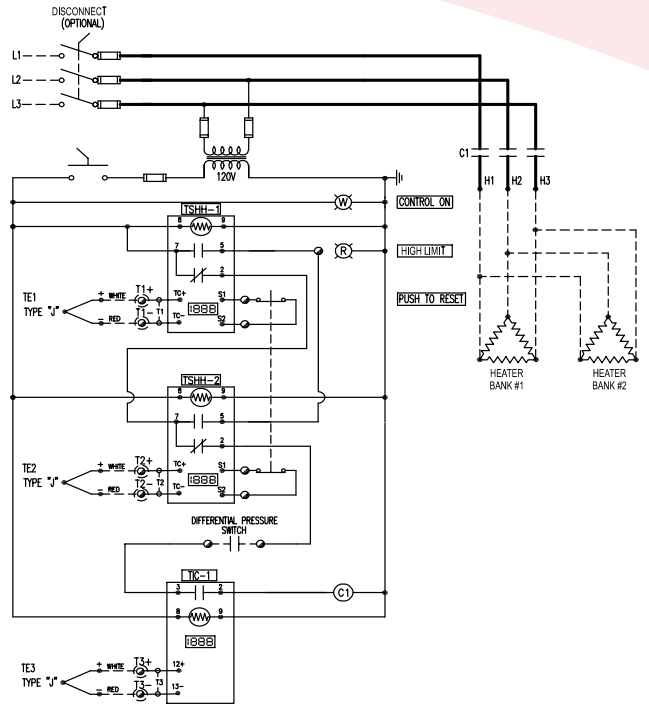

Notes:
 ONE HIGH LIMIT CONTROL PROVIDED ON SINGLE BANK HEATERS.
 TWO HIGH LIMIT CONTROLS PROVIDED ON DOUBLE BANK HEATERS.

Package #3 - SCR with Remote Temperature Controller

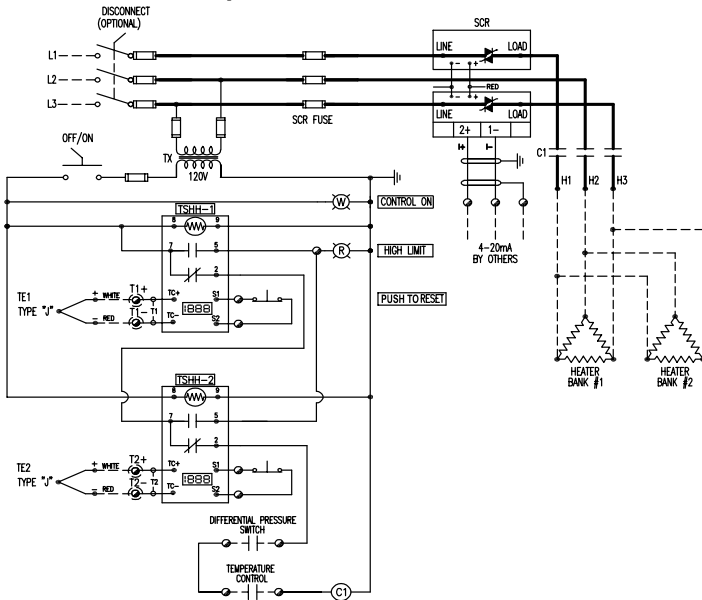

Notes:
 ONE HIGH LIMIT CONTROL PROVIDED ON SINGLE BANK HEATERS.
 TWO HIGH LIMIT CONTROLS PROVIDED ON DOUBLE BANK HEATERS.

Package #4 - SCR with Built-in Temperature Controller

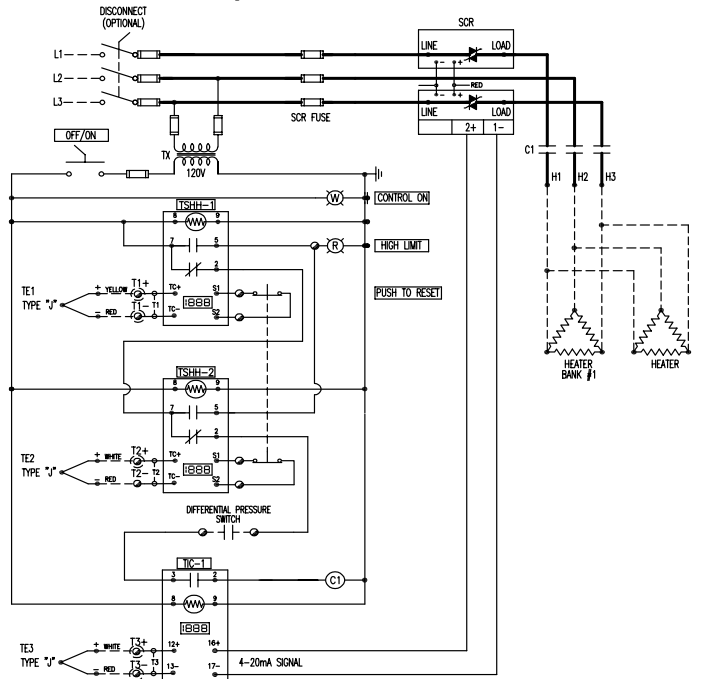

Notes:
 ONE HIGH LIMIT CONTROL PROVIDED ON SINGLE BANK HEATERS.
 TWO HIGH LIMIT CONTROLS PROVIDED ON DOUBLE BANK HEATERS.

Control Panels for RXDF Duct Heaters Type RCPXD

Ruffneck™ type RXDF duct heaters are normally supplied with a type RCPXD control panel. These control panels are available in two basic types - type 4 moisture resistant or explosion proof - and with four different control packages as listed.

Standard Features

All RCPXD control panels are supplied with magnetic contactors, HRC fusing, fused 120V control transformer, high limit controls, control circuit, ON/OFF switch, control ON light, high limit indicator light, high limit push-to-reset, terminals for connection of temperature controls and differential air pressure switch.

Enclosure Types

RCPXD control panels are available with either type 4 moisture resistant enclosures or explosion-proof enclosures rated Class I, Div. 1 & 2, Groups C, D and Class II, Div. 1 & 2, Groups E, F, G.

Control Packages

Package #1 - Basic Unit (ON/OFF Control)

All standard features. Terminals are provided for connection to a remote ON/OFF temperature controller and connection of differential air pressure switch.

Package #2 - Built-in Temperature Controller

Same features as Package #1 except with factory installed digital temperature controller for control of outlet air temperature.

Package #3 - SCR with Remote Temperature Controller

All standard features and a factory installed full load zero fired SCR with terminals provided for remote 4-20 mA temperature control signal and connection of differential air pressure switch.

Package #4 - SCR with Built-in Temperature Controller

Same features as Package #3 except with factory installed digital temperature controller for control of outlet air temperature.

Note: Some amperage limits apply to packages #3 and #4 in E.P. Enclosure. Consult factory for details.

Control Panel Specifications

ENCLOSURE TYPE	NUMBER OF CIRCUITS	kW	AVAILABLE VOLTAGES				CATALOG NUMBER			
			208V 3 φ	240V 3 φ	480V 3 φ	600V 3 φ	PACKAGE #1	PACKAGE #2	PACKAGE #3	PACKAGE #4
TYPE 4 MOISTURE RESISTANT	1	2.5	✓	✓	✓	✓	RCPXD1-025R	RCPXD1-025TR	RCPXD1-025SR	RCPXD1-025STR
		3.75	✓	✓	✓	✓	RCPXD1-038R	RCPXD1-038TR	RCPXD1-038SR	RCPXD1-038STR
		5	✓	✓	✓	✓	RCPXD1-050R	RCPXD1-050TR	RCPXD1-050SR	RCPXD1-050STR
		6.25	✓	✓	✓	✓	RCPXD1-063R	RCPXD1-063TR	RCPXD1-063SR	RCPXD1-063STR
		7.5	✓	✓	✓	✓	RCPXD1-075R	RCPXD1-075TR	RCPXD1-075SR	RCPXD1-075STR
		10	✓	✓	✓	✓	RCPXD1-100R	RCPXD1-100TR	RCPXD1-100SR	RCPXD1-100STR
		12.5	✓	✓	✓	✓	RCPXD1-125R	RCPXD1-125TR	RCPXD1-125SR	RCPXD1-125STR
		15	✓	✓	✓	✓	RCPXD1-150R	RCPXD1-150TR	RCPXD1-150SR	RCPXD1-150STR
		20	✓	✓	✓	✓	RCPXD1-200R	RCPXD1-200TR	RCPXD1-200SR	RCPXD1-200STR
		25	—	✓	✓	✓	RCPXD1-250R	RCPXD1-250TR	RCPXD1-250SR	RCPXD1-250STR
	2	5	✓	✓	✓	✓	RCPXD2-050R	RCPXD2-050TR	RCPXD2-050SR	RCPXD2-050STR
		7.5	✓	✓	✓	✓	RCPXD2-075R	RCPXD2-075TR	RCPXD2-075SR	RCPXD2-075STR
		10	✓	✓	✓	✓	RCPXD2-100R	RCPXD2-100TR	RCPXD2-100SR	RCPXD2-100STR
		12.5	✓	✓	✓	✓	RCPXD2-125R	RCPXD2-125TR	RCPXD2-125SR	RCPXD2-125STR
		15	✓	✓	✓	✓	RCPXD2-150R	RCPXD2-150TR	RCPXD2-150SR	RCPXD2-150STR
		20	✓	✓	✓	✓	RCPXD2-200R	RCPXD2-200TR	RCPXD2-200SR	RCPXD2-200STR
		25	—	✓	✓	✓	RCPXD2-250R	RCPXD2-250TR	RCPXD2-250SR	RCPXD2-250STR
		30	—	—	✓	✓	RCPXD2-300R	RCPXD2-300TR	RCPXD2-300SR	RCPXD2-300STR
		40	—	—	✓	✓	RCPXD2-400R	RCPXD2-400TR	RCPXD2-400SR	RCPXD2-400STR
		50	—	—	✓	✓	RCPXD2-500R	RCPXD2-500TR	RCPXD2-500SR	RCPXD2-500STR
EXPLOSION PROOF CLASS I, GROUP C & D CLASS II, GROUP E, F, & G	1	2.5	✓	✓	✓	✓	RCPXD1-025X	RCPXD1-025TX	RCPXD1-025SX	RCPXD1-025STX
		3.75	✓	✓	✓	✓	RCPXD1-038X	RCPXD1-038TX	RCPXD1-038SX	RCPXD1-038STX
		5	✓	✓	✓	✓	RCPXD1-050X	RCPXD1-050TX	RCPXD1-050SX	RCPXD1-050STX
		6.25	✓	✓	✓	✓	RCPXD1-063X	RCPXD1-063TX	RCPXD1-063SX	RCPXD1-063STX
		7.5	✓	✓	✓	✓	RCPXD1-075X	RCPXD1-075TX	RCPXD1-075SX	RCPXD1-075STX
		10	✓	✓	✓	✓	RCPXD1-100X	RCPXD1-100TX	RCPXD1-100SX	RCPXD1-100STX
		12.5	✓	✓	✓	✓	RCPXD1-125X	RCPXD1-125TX	RCPXD1-125SX	RCPXD1-125STX
		15	✓	✓	✓	✓	RCPXD1-150X	RCPXD1-150TX	RCPXD1-150SX	RCPXD1-150STX
		20	✓	✓	✓	✓	RCPXD1-200X	RCPXD1-200TX	RCPXD1-200SX	RCPXD1-200STX
		25	—	—	✓	✓	RCPXD1-250X	RCPXD1-250TX	RCPXD1-250SX	RCPXD1-250STX
	2	5	✓	✓	✓	✓	RCPXD2-050X	RCPXD2-050TX	RCPXD2-050SX	RCPXD2-050STX
		7.5	✓	✓	✓	✓	RCPXD2-075X	RCPXD2-075TX	RCPXD2-075SX	RCPXD2-075STX
		10	✓	✓	✓	✓	RCPXD2-100X	RCPXD2-100TX	RCPXD2-100SX	RCPXD2-100STX
		12.5	✓	✓	✓	✓	RCPXD2-125X	RCPXD2-125TX	RCPXD2-125SX	RCPXD2-125STX
		15	✓	✓	✓	✓	RCPXD2-150X	RCPXD2-150TX	RCPXD2-150SX	RCPXD2-150STX
		20	✓	✓	✓	✓	RCPXD2-200X	RCPXD2-200TX	RCPXD2-200SX	RCPXD2-200STX
		25	—	✓	✓	✓	RCPXD2-250X	RCPXD2-250TX	RCPXD2-250SX	RCPXD2-250STX
		30	—	—	✓	✓	RCPXD2-300X	RCPXD2-300TX	RCPXD2-300SX	RCPXD2-300STX
		40	—	—	✓	✓	RCPXD2-400X	RCPXD2-400TX	RCPXD2-400SX	RCPXD2-400STX
		50	—	—	✓	✓	RCPXD2-500X	RCPXD2-500TX	RCPXD2-500SX	RCPXD2-500STX

Note: For optional disconnect switch, add suffix 'D' to end of catalog number.

RXDF

Explosion-Proof Heaters Type RXDF Specification Sheet

1.0 Scope

Electric explosion-proof duct heaters shall be **Ruffneck™ type RXDF**, as manufactured by CCI Thermal Technologies Inc., complete with all standard equipment and optional features as specified below.

2.0 General

- 2.1 The heater is to be CCSAUS certified with ratings as specified in 3.0.
- 2.2 The heater shall be provided with standard features and optional features as outlined in 4.0 and 6.0.

3.0 Specifications and Ratings

- 3.1 The duct heater shall be designed to heat air at _____ SCFM from _____°F to _____°F (_____°C to _____°C).
- 3.2 The heater shall be of the explosion-proof, duct type, catalog number _____, rated _____ V, _____ Phase, _____ Hz, _____ kW with the following hazardous locations rating.
 Class _____, Divisions _____, Groups _____;
 Class _____, Divisions _____, Groups _____.
- 3.3 The duct heater shall be marked with a _____ temperature code, or maximum surface temperature of _____.
- 3.4 The minimum rated airflow through the duct heater shall be _____ SCFM.
- 3.5 The maximum outlet temperature of the duct heater shall not exceed _____°F (_____°C).
- 3.6 The duct heater is to be mounted in a horizontal duct section downstream / upstream from the customer supplied blower.
- 3.7 The duct heater shall be suitable for operation in a -40°F (-40°C) min. to 104°F (40°C) max. ambient temperature.

4.0 Standard Features - Duct Heater

- 4.1 The duct heater shall be supplied with a _____" (H) × _____" (W) × _____" (L) carbon steel duct section with 1" wide mounting flange and painted ASA61 gray epoxy outside and high temperature aluminum inside.
- 4.2 The heating elements shall be 0.475" dia. (12 mm), extra heavy wall 0.095" (2 mm) finned tubular steel with nickel plated finish. Fins are to be fully brazed to the element sheath for maximum performance and efficiency.
- 4.3 The heating elements shall extend through CCI Thermal Technologies Inc. certified explosion-proof compression fittings into a patented **x-Max®** explosion-proof, extruded copper-free aluminum terminal housing(s) with 1¼" NPT power conduit entry and ¾" NPT conduit entry for high limit thermocouple connection.
- 4.4 The heating elements shall be mounted as _____ removable heating bank(s) and wired to terminal blocks for _____ × _____ kW, _____ V, _____ phase heating circuits to be fully SCR controlled, or ON/OFF control.
- 4.5 The duct heater shall be supplied with _____ 'J' type sheathed thermocouples welded or brazed to the element sheath for connection to customer supplied / factory installed certified high limit controllers. High limit set points will be factory preset.
- 4.6 An explosion-proof differential pressure switch is supplied as standard for field wiring to the remote control panel. Switch is intended to prove that the minimum airflow is maintained at all times. The differential pressure switch is to be:
 factory mounted on the heater supplied loose for field installation.
- 4.7 The duct heater shall be mounted in a horizontal duct section with the terminal box(es) at the side.
- 4.8 The approximate weight of the duct heater shall be _____ lbs

5.0 Standard Features - Control Package

- 5.1 Enclosure type (check one):
 Type 4 - moisture-proof Explosion-proof
- 5.2 Temperature control (check one):
 Basic unit - customer supplied temperature control signal Built-in temperature controller
 SCR controller - customer supplied 4 - 20 mA control signal SCR controller with built-in temperature controller

6.0 Optional Features and Equipment (check as desired)

- Stainless-steel duct section
- Transition sections to _____" (H) × _____" (W) duct or _____" round duct.
- Special temperature code of _____.

RXDF

Air Duct Heaters Types RDFF, RDIF, RDFT & RDIT

Application

Ruffneck™ air duct heaters are for use in comfort heating applications. Typical applications include:

- make-up air heating
- air pre-heating
- air handling equipment
- fan coils
- terminal reheating
- multi-zone reheating
- heat pump auxiliary systems
- return air heating

In Canada these units are marketed under the Caloritech™ brand name. Refer to Caloritech™ Catalogue Section C.

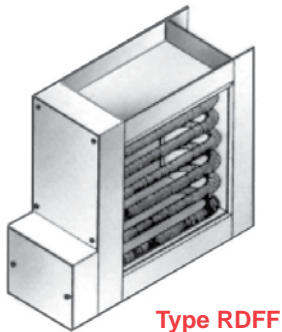

Type RDFF

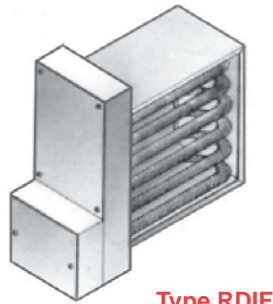

Type RDIF

Type RDFF is a flanged duct heater with finned tubular heating elements.

Type RDIF is an insert duct heater with finned tubular heating elements.

Type RDFT is a flanged duct heater with incoloy® (nonfinned) tubular heating elements.

Type RDIT is an insert duct heater with tubular heating elements.

Standard Features

- Primary linear cutout: 160°F (71°C) 277/600 VAC, 25/10 amp non-inductive
- Secondary linear cutout: Manual reset complete with back-up magnetic contactor on units under 300V, 30 kW and less, 225°F (107°C) 277/600 VAC, 25/10 amp non-inductive

Optional Auxiliary Duct Heater Controls



These controls are available as factory installed on the duct heater or as an EEMAC rated (specify) control panel for wall mount:

- wall thermostats - T498A T6051A (1 stage) T6052A (2 stage) T921A (0 - 135 ohm)
- duct thermostats - T675A (1 stage) T678A (2 stage) T991A (0 - 135 ohm)
- bulb holders
- silent contactors
- SCR controllers
- sail switch
- differential pressure switch
- main disconnect
- pneumatic electric switches
- on-off switch
- magnetic contactors
- step controllers
- HRC fusing
- control transformers
- fan interlock relay
- pilot lights

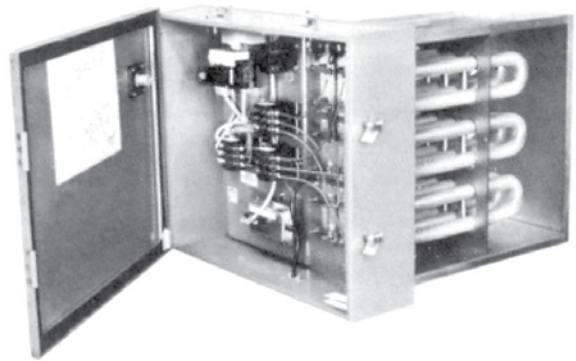

Element Types

The finned tubular element design is the most popular. It incorporates the highest wattage per cross-sectional duct area, thus making it more economical than the incoloy® tubular design.

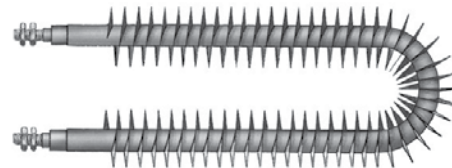

Fig. 1 - Finned Tubular Elements

Finned tubular elements are constructed using a steel tube with a corrugated steel fin wrapped around it and brazed together. This increases the heat transfer surface of the element resulting in a lower operating temperature than tubular designs.

RDFF, RDIF, RDFT & RDIT

Element Types (continued)

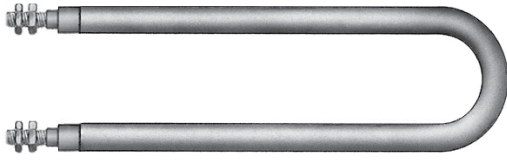

Fig. 2 - Tubular Elements

Incoloy® tubular elements are similarly constructed, but without the steel fin in order to increase the corrosion resistance.

The Incoloy® design should be chosen where high humidity or slightly corrosive chemical contaminants are present in the air stream. These units are made and approved on special order only.

Both element types are designed to provide many years of maintenance free service.

Unlike open coil designs, duct heaters fitted with tubular elements are not subject to hazards of electrical shock which allows installation close to a register or grille.

Recommended Kilowatts

In order to select the proper kW for your application, use Figure 3 below.

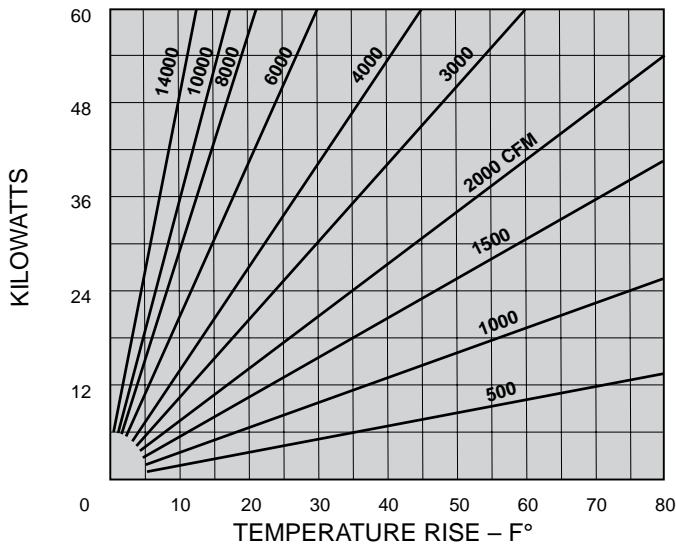

Fig. 3 - Recommended Kilowatts

Wiring and Auxiliary Controls

Ruffneck™ electric duct heaters are available for supply voltages up to 600V, 3 phase. Multi-staging to provide increments of temperature rise can be incorporated where dimensional space and element spacing allows. Special electrical features are available providing simple or sophisticated temperature control to suit individual requirements. See optional controls on previous page.

Construction

Two basic heater frame constructions are available, flange type or insert type (see Figures 4 and 5 below).

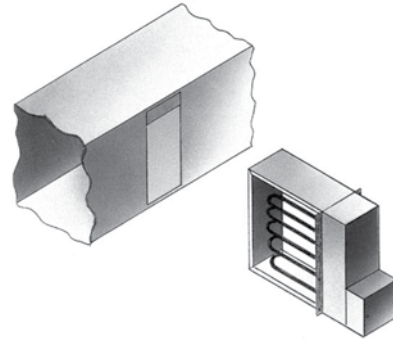

Fig. 4 - Insert Type

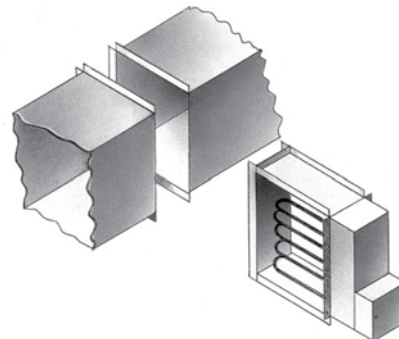

Fig. 5 - Flange Type

All frames are fabricated from 16-gauge satin-coat steel. Specially constructed stainless-steel frames are also available.

A unique modular construction using stock frame components is employed using vertical and horizontal dimensional increments of two inches, ensuring rapid delivery.

RDF, RDIF, RDFT & RDIT

Standard Dimensions

Insert type duct heaters are slightly undersized to permit installation in ducts having the A and B dimensions listed in Table 1.

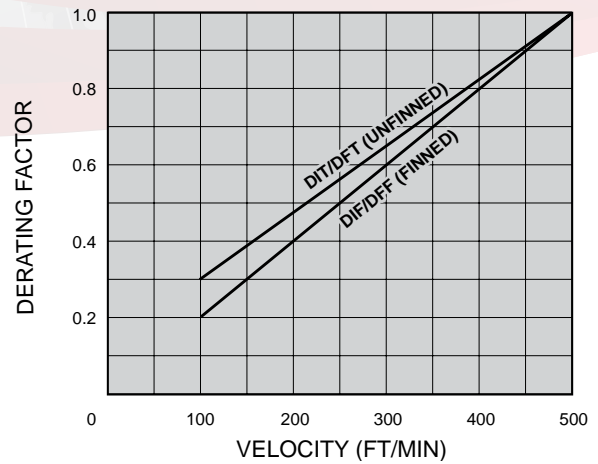

Fig.7 - Derating Factors

Selection and Installation

Finned tubular duct heaters are approved for horizontal duct installation where the maximum inlet air temperature does not exceed 77°F (25°C) and the maximum rating does not exceed 120 kW.

Multiple heaters can be installed in tandem (series) provided that the inlet temperature to any heater section (one heater) is not more than 77°F (25°C) and the air velocity is not less than the requirements of Figure 6. Check factory if you require assistance.

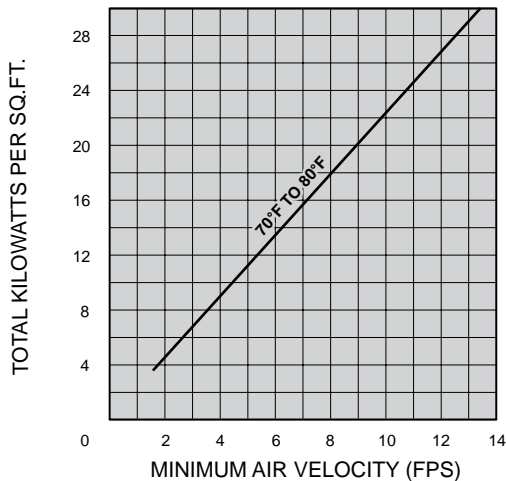

Fig. 6 - Air Velocity Requirements

See Table 1 for typical duct heater sizes and kW ratings based on an air flow velocity of 500 ft/min or higher.

If the flow velocity is less than 500 ft/min, the typical maximum kW ratings in the table must be derated using Figure 7.

Multiply the kW ratings shown in Table 1 by the appropriate derating factor from Figure 7.

Table 1 below lists some of the more common heater sizes with maximum kilowatt ratings for each size. Stock modular frames allow quick delivery for other sizes in increments of 2" (51 mm).

TABLE 1 - Maximum Single Heater kW Rating for Typical Duct Heater Sizes

DIMENSIONS in. (mm) A x B	Types RDIF / RDFF		Types RDIT / RDFT	
	MAX. kW	MAX. No. OF ELEMS.	MAX. kW	MAX. No. OF ELEMS.
6 x 6 (125 x 152)	2.5	3	1.5	6
8 x 6 (203 x 152)	3	3	3.0	6
10 x 6 (254 x 152)	4	3	2.5	6
10 x 8 (254 x 203)	5.5	4	3.5	8
12 x 6 (305 x 125)	5	3	3.5	6
12 x 8 (305 x 203)	6.5	4	4.5	8
12 x 10 (305 x 254)	8	5	5.5	10
14 x 8 (356 x 203)	7.5	4	5.5	8
14 x 10 (356 x 254)	9.5	5	6.5	10
14 x 12 (356 x 305)	11.5	6	8.0	12
16 x 10 (406 x 254)	11	5	7.5	10
16 x 12 (406 x 305)	13	6	9.0	12
16 x 14 (406 x 356)	15.5	7	10.5	14
18 x 12 (457 x 305)	15	6	10.5	12
18 x 14 (457 x 356)	17.5	7	12	14
18 x 16 (457 x 406)	20	8	14	16
20 x 14 (508 x 356)	19	7	13.5	14
20 x 16 (508 x 406)	22	8	13.5	16
20 x 18 (508 x 457)	25	9	17.5	18
22 x 16 (559 x 406)	24	8	17	16
22 x 18 (406 x 457)	27.5	9	19	18
22 x 20 (406 x 508)	30.5	10	21	20
24 x 18 (610 x 457)	30	9	21	18
24 x 20 (610 x 508)	33	10	23	20
24 x 22 (610 x 559)	36.5	11	25.5	22
26 x 20 (660 x 508)	36	10	25	20
26 x 22 (660 x 406)	39.5	11	27.5	22
26 x 24 (660 x 610)	43	12	30	24
28 x 22 (711 x 559)	42.5	11	29.5	22
28 x 24 (711 x 610)	46.5	12	32.5	24
28 x 26 (711 x 660)	50.5	13	35	26
30 x 24 (762 x 610)	50	12	35	24
30 x 26 (762 x 660)	54	13	37.5	26
30 x 28 (762 x 711)	58	14	40.5	28
30 x 30 (762 x 762)	62.5	15	43.5	30

RDFF, RDIF, RDFT & RDIT

Ruffneck™ FR Heat Exchanger Unit Heaters are extra heavy duty (including heavy gauge steel construction) to meet the most demanding service and long life requirements for rugged industrial applications. The FR Series heaters are specifically designed for steam applications that may be subject to freezing conditions, and are of particular value for outdoor applications. Explosion-proof models suitable for hazardous locations are available on custom order.

Engineered for ease of maintenance, all parts are easily removed. All fasteners are plated capscrews; no sheet metal screws are used. Heat exchanger cores are of steel construction with tension wound, close fitting aluminium fins. They are resistant to corrosive agents (including hydrogen sulphide).

All units are equipped with a narrow-gap, epoxy coated fan guard. Choose from several optional UL listed and/or CSA approved motors with various voltages, phases and frequencies. All FR models have Canadian CRN approvals and are CSA certified for hazardous locations: Class I, Divisions 1 & 2, Groups C & D; Class II, Division 1 & 2, Groups E, F, & G; Class III, Division 1 & 2; Temperature Code T3B 329°F (165°C) - (on applicable models only).

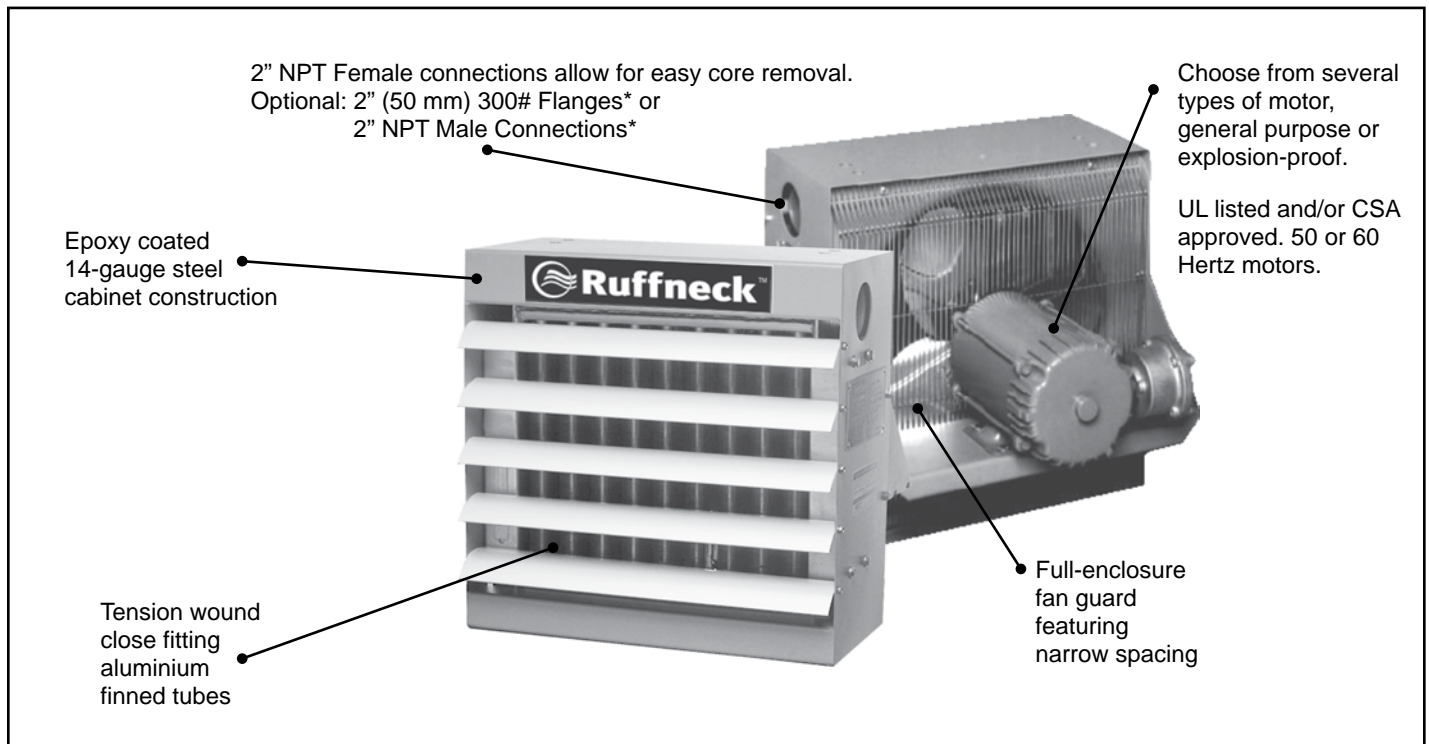

Heresite® is a registered trademark of Heresite® Protective Coatings Inc.
* 2" 300# Flanges and 2" NPT Male Connections increase difficulty in core removal.

Model Coding

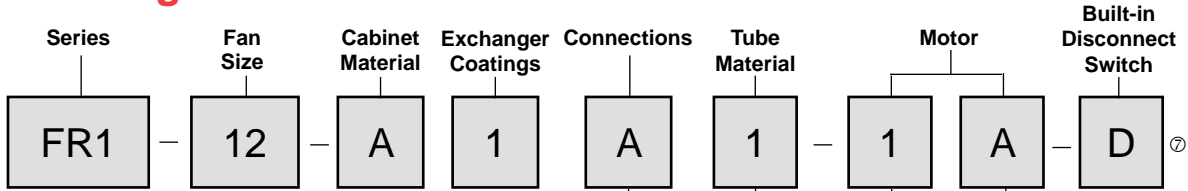

FAN SIZE	MODEL & SIZE	
FR1-12 THRU FR1-36	1 - Pass	FR1

FAN SIZE	
12" DIA	12
16" DIA	16
20" DIA	20
24" DIA	24
30" DIA	30
36" DIA	36

CABINET MATERIAL	
EPOXY POWDER COATED CARBON STEEL	A
HERESITE® PHENOLIC COATED CARBON STEEL	B
STAINLESS STEEL	C

EXCHANGER COATINGS	
HEAT RESISTANT ALUMINUM PAINT	1
HERESITE® PHENOLIC COATING	2

CONNECTIONS	
2" NPT FEMALE	A
2" NPT MALE, SCH. 80	B
2" 300# RF FLANGE	C

MOTOR ELECTRICAL SPECIFICATIONS			
	VOLTS	PHASE	HERTZ
A	115	1	60
B	208	1	60
C	208	3	60
D	230	1	60
E	230	3	60
F	460	1	60
G	460	3	60
H	575	3	60
I	220	1	50
J	380	3	50
K	440	3	50

HEATER CERTIFICATION	
1	General Purpose
2	X-proof, groups C, D, E, F, & G
3	CSA Certified Heater

TUBE MATERIAL						
	WALL THICKNESS	ROWS	FINNING			TUBING
			FINS/ INCH	MATERIAL	TYPE	
A	.065" (1.7 mm)	3	10	AL	TW	5/8" (16 mm)

TW = Tension Wound
EX = Extruded
AL = Aluminum

NOTE:
Ruffneck™ utilizes Doerr/Emerson/Baldor as our standard motor. Specifying any other O.E.M. motor may result in longer lead times. All heat exchangers are registered to C.R.N. OH0224.2C.
They are approved for use in all provinces and territories in Canada.
① Heresite® coated exchangers and cabinets: contact factory for quote.
② Louvres and fan blades are also Heresite® coated.
③ Contact factory for shipping lead time.
④ Motor designed to be used at rated voltage with tolerances of ±15%.
⑤ Motor may be marked 230V, but is suitable for 208V operation.
⑥ 460 1 phase motors are only certified for groups D, F & G.
⑦ Built-in Disconnect only available with CSA certified heaters.

FR Single-Pass

The Ruffneck™ FR Series is designed for steam applications that may be subject to freezing conditions. Maximum operating pressure is to 100 psi.

This heater is of particular value for outdoor applications, such as on drilling rigs, where boiler failure or crew neglect may result in an accidental freeze-up of the heating system. If accidental freeze-up occurs it is highly recommended the heater be returned to CCI Thermal for inspection.

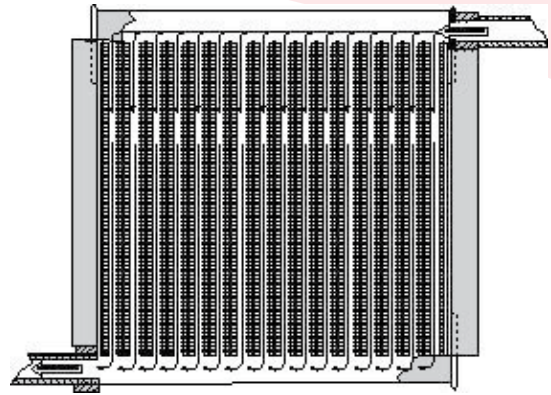
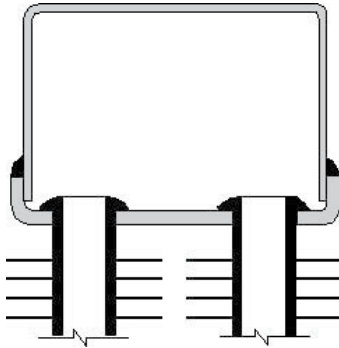

The fluid flow is divided among all tubes. This is best suited to steam and high flow rate liquid applications.

Optional Built-in Disconnect available.

The Ruffneck™ Disconnect Switch is engineered for use in the most demanding applications such as drilling rigs, utilidors and compression stations where high vibration, dirt, moisture, fluctuating power and high impact conditions exist. The Built-in Disconnect Switch is available on all Ruffneck™ FR heaters.

Performance Data for FR1-12

ENTERING STEAM PARAMETERS		ENTERING AIR TEMPERATURE °F										
psig	°F		-10	0	10	20	30	40	50	60	70	80
2	219	OUTPUT (MBH)				57.3	54.1	50.8	47.7	44.6	41.5	38.4
		COND. (lbs/hr)	-	-	-	57.9	54.6	51.4	48.2	45.0	41.9	38.8
		FAT (°F)				67.4	75.7	83.8	91.9	100.0	107.9	115.8
10	239	OUTPUT (MBH)				63.7	60.4	57.1	53.8	50.6	47.5	44.4
		COND. (lbs/hr)	-	-	-	65.3	61.8	58.5	55.2	51.9	48.7	45.5
		FAT (°F)				72.7	81.0	89.3	97.4	105.5	113.5	121.4
20	259	OUTPUT (MBH)			73.6	70.1	66.7	63.3	60.0	56.8	53.6	50.4
		COND. (lbs/hr)	-	-	76.3	72.7	69.2	65.7	62.3	58.9	55.5	52.3
		FAT (°F)			69.7	78.1	86.5	94.7	102.9	111.0	119.1	127.1
40	287	OUTPUT (MBH)		86.3	82.7	79.1	75.6	72.2	68.8	65.4	62.2	58.9
		COND. (lbs/hr)	-	91.4	87.5	83.8	80.0	76.4	72.8	69.2	65.7	62.3
		FAT (°F)		68.7	77.2	85.7	94.1	102.5	110.7	118.9	127.0	135.1
60	307	OUTPUT (MBH)	96.7	92.9	89.3	85.6	82.1	78.6	75.1	71.7	68.3	65.0
		COND. (lbs/hr)	104.2	100.1	96.1	92.2	88.3	84.5	80.8	77.1	73.5	69.9
		FAT (°F)	65.4	74.0	82.7	91.2	99.7	108.0	116.3	124.6	132.7	140.8
80	324	OUTPUT (MBH)	102.4	98.6	94.9	91.2	87.5	84.0	80.5	77.0	73.6	70.2
		COND. (lbs/hr)	111.8	107.6	103.5	99.4	95.5	91.6	87.7	83.9	80.2	76.5
		FAT (°F)	69.9	78.6	87.3	95.9	104.4	112.8	121.2	129.4	137.6	145.8
100	338	OUTPUT (MBH)	107.1	103.3	99.5	95.7	92.1	88.5	84.9	81.4	77.9	74.5
		COND. (lbs/hr)	118.3	114.1	109.8	105.7	101.6	97.6	93.7	89.8	86.0	82.2
		FAT (°F)	73.6	82.4	91.1	99.7	108.3	116.8	125.1	133.5	141.7	149.9

Refer to the Ruffneck™ HP model for service above 100 psi.
For 50 Hz power supply, derate output by 10%

Performance Data for FR1-16

ENTERING STEAM PARAMETERS		ENTERING AIR TEMPERATURE °F										
psig	°F		-10	0	10	20	30	40	50	60	70	80
2	219	OUTPUT (MBH)				95.3	89.8	84.5	79.2	74.0	68.9	63.8
		COND. (lbs/hr)				96.8	91.2	85.8	80.4	75.2	70.0	64.8
		FAT (°F)				69.8	77.9	86.0	94.0	101.9	109.8	117.6
10	239	OUTPUT (MBH)			111.5	105.8	100.3	94.8	89.4	84.1	78.9	73.7
		COND. (lbs/hr)			114.8	109.0	103.3	97.6	92.1	86.6	81.2	75.9
		FAT (°F)			67.1	75.3	83.5	91.7	99.7	107.7	115.6	123.4
20	259	OUTPUT (MBH)			122.2	116.4	110.7	105.2	99.7	94.2	88.9	83.6
		COND. (lbs/hr)			127.4	121.4	115.5	109.6	103.9	98.2	92.7	87.2
		FAT (°F)			72.7	81.0	89.2	97.4	105.5	113.5	121.4	129.3
40	287	OUTPUT (MBH)		143.3	137.3	131.4	125.5	119.8	114.1	108.5	103.1	97.6
		COND. (lbs/hr)		152.6	146.1	139.8	133.6	127.4	121.4	115.5	109.6	103.9
		FAT (°F)		72.1	80.5	88.9	97.2	105.5	113.6	121.7	129.7	137.7
60	307	OUTPUT (MBH)	160.5	154.3	148.1	142.1	136.1	130.3	124.5	118.8	113.2	107.7
		COND. (lbs/hr)	173.9	167.1	160.4	153.9	147.4	141.0	134.8	128.6	122.6	116.6
		FAT (°F)	69.1	77.7	86.2	94.7	103.0	111.3	119.5	127.7	135.7	143.7
80	324	OUTPUT (MBH)	170.0	163.6	157.4	151.2	145.2	139.2	133.4	127.6	121.9	116.4
		COND. (lbs/hr)	186.6	179.6	172.7	165.9	159.3	152.7	146.2	140.0	133.7	127.6
		FAT (°F)	73.8	82.5	91.1	99.6	108.0	116.3	124.6	132.7	140.8	148.9
100	338	OUTPUT (MBH)	177.8	171.3	165.0	158.8	152.7	146.6	140.7	134.9	129.1	123.5
		COND. (lbs/hr)	197.6	190.4	183.3	176.4	169.5	162.8	156.2	149.7	143.3	137.0
		FAT (°F)	77.8	86.5	95.1	103.6	112.1	120.4	128.7	136.9	145.1	153.1

Refer to the Ruffneck™ HP model for service above 100 psi. Above figures are based on calculations at sea level and are intended as reference material only. Results may vary due to customer applications.

Performance Data for FR1-20

ENTERING STEAM PARAMETERS		ENTERING AIR TEMPERATURE °F										
psig	°F		-10	0	10	20	30	40	50	60	70	80
2	219	OUTPUT (MBH)				161.1	151.9	142.9	134.0	125.2	116.5	108.0
		COND. (lbs/hr)				164.4	155.0	145.8	136.7	127.8	119.0	110.2
		FAT (°F)				68.3	76.5	84.6	92.7	100.7	108.6	116.5
10	239	OUTPUT (MBH)			188.4	178.9	169.5	160.3	151.2	142.2	133.4	124.7
		COND. (lbs/hr)			195.2	185.3	175.6	166.0	156.6	147.3	138.1	129.7
		FAT (°F)			65.4	73.7	82.0	90.1	98.3	106.3	114.3	122.2
20	259	OUTPUT (MBH)			206.6	196.9	187.3	177.9	168.6	159.4	150.4	141.5
		COND. (lbs/hr)			216.7	206.4	196.4	186.5	176.7	167.1	157.7	148.3
		FAT (°F)			70.8	79.2	87.5	95.7	103.9	112.0	120.0	128.0
40	287	OUTPUT (MBH)		242.3	232.2	222.2	212.3	202.6	193.0	183.7	174.4	165.3
		COND. (lbs/hr)		259.4	248.5	237.8	227.2	216.8	206.6	196.5	186.6	176.8
		FAT (°F)		69.9	78.5	86.9	95.3	103.6	111.8	120.0	128.0	136.0
60	307	OUTPUT (MBH)	271.4	260.9	250.5	240.3	230.3	220.4	210.7	201.1	191.6	182.3
		COND. (lbs/hr)	295.7	284.2	272.9	261.7	250.8	240.0	229.4	218.9	208.6	198.5
		FAT (°F)	66.7	75.4	84.0	92.5	100.9	109.3	117.5	125.7	133.9	141.9
80	324	OUTPUT (MBH)	287.4	276.7	266.1	255.8	245.6	235.6	225.7	216.0	206.4	196.9
		COND. (lbs/hr)	317.4	305.5	293.8	282.3	271.1	260.0	249.0	238.3	227.7	217.3
		FAT (°F)	71.4	80.1	88.7	97.3	105.7	114.1	122.4	130.7	138.9	146.9
100	338	OUTPUT (MBH)	300.6	289.7	279.1	268.6	258.2	248.1	238.1	228.2	218.5	209.0
		COND. (lbs/hr)	336.0	323.9	311.9	300.1	288.6	277.2	266.0	255.0	244.1	233.4
		FAT (°F)	75.2	83.9	92.6	101.2	109.7	118.1	126.5	134.8	143.0	151.1

Refer to the Ruffneck™ HP model for service above 100 psi. For 50 Hz power supply, derate output by 10%.

Performance Data for FR1-24

ENTERING STEAM PARAMETERS		ENTERING AIR TEMPERATURE °F										
psig	°F		-10	0	10	20	30	40	50	60	70	80
2	219	OUTPUT (MBH)	384.4	364.4	344.7	325.4	306.4	287.7	269.4	251.4	233.7	216.3
		COND. (lbs/hr)	393.6	373.0	352.8	333.0	313.6	294.5	275.7	257.3	239.2	221.3
		FAT (°F)	79.7	86.0	93.9	100.9	107.7	114.4	121.1	127.6	134.0	140.3
10	239	OUTPUT (MBH)	421.4	400.9	380.7	360.9	341.5	322.4	303.6	285.2	267.1	249.3
		COND. (lbs/hr)	437.8	416.4	395.4	374.9	354.7	334.8	315.3	296.2	277.4	258.8
		FAT (°F)	88.6	95.8	103.0	110.0	116.9	123.6	130.3	136.9	143.4	149.7
20	259	OUTPUT (MBH)	458.5	437.5	416.9	396.6	376.7	357.2	338.1	319.2	300.7	282.5
		COND. (lbs/hr)	482.3	460.1	438.4	417.1	396.2	375.6	355.4	335.6	316.1	297.0
		FAT (°F)	97.6	104.9	112.1	119.1	126.1	132.9	139.7	146.3	152.8	159.2
40	287	OUTPUT (MBH)	510.6	488.9	467.6	446.8	426.3	406.2	386.5	367.1	348.0	329.3
		COND. (lbs/hr)	548.3	525.0	502.1	479.7	457.6	436.0	414.8	394.0	373.5	353.4
		FAT (°F)	110.3	117.7	125.0	132.1	139.2	146.1	152.9	159.6	166.2	172.7
60	307	OUTPUT (MBH)	547.8	525.7	504.0	482.7	461.8	441.3	421.2	401.1	382.0	362.9
		COND. (lbs/hr)	598.7	574.5	550.7	527.4	504.5	482.0	460.0	438.4	417.2	396.3
		FAT (°F)	119.5	127.0	134.3	141.5	148.6	155.6	162.5	169.2	175.9	182.4
80	324	OUTPUT (MBH)	579.5	557.0	534.9	513.3	492.1	471.2	450.8	430.7	410.9	391.5
		COND. (lbs/hr)	641.9	616.9	592.4	568.4	544.8	521.7	499.0	476.7	454.8	433.3
		FAT (°F)	127.3	134.8	142.2	149.5	156.7	163.7	170.6	177.5	184.2	190.8
100	338	OUTPUT (MBH)	605.7	582.8	560.5	538.5	517.0	495.9	475.2	454.8	434.8	415.2
		COND. (lbs/hr)	679.3	653.6	628.4	603.8	579.6	555.8	532.5	509.7	487.2	465.2
		FAT (°F)	133.8	141.4	148.8	156.2	163.4	170.4	177.4	184.3	191.0	197.7

Refer to the Ruffneck™ HP model for service above 100 psi. Above figures are based on calculations at sea level and are intended as reference material only. Results may vary due to customer applications.

Performance Data for FR1-30

ENTERING STEAM PARAMETERS		ENTERING AIR TEMPERATURE °F										
psig	°F		-10	0	10	20	30	40	50	60	70	80
2	219	OUTPUT (MBH)	559.5	530.0	501.1	472.7	444.9	417.6	390.8	364.5	338.6	331.2
		COND. (lbs/hr)	573.7	543.4	513.7	484.6	456.1	428.1	400.6	373.6	347.1	321.0
		FAT (°F)	87.7	94.6	101.3	107.9	114.4	120.8	127.1	133.3	139.4	145.4
10	239	OUTPUT (MBH)	612.7	582.5	552.9	523.8	495.4	467.4	440.0	413.1	386.7	360.7
		COND. (lbs/hr)	637.5	606.0	575.2	544.9	515.3	486.2	457.7	429.7	402.1	375.1
		FAT (°F)	97.4	104.3	111.1	117.8	124.3	130.8	137.1	143.3	149.5	155.5
20	259	OUTPUT (MBH)	666.0	635.1	604.8	575.1	546.0	517.4	489.4	461.9	434.9	408.4
		COND. (lbs/hr)	701.7	669.1	637.1	605.8	575.1	545.0	515.4	486.4	458.0	430.0
		FAT (°F)	107.1	114.1	120.9	127.7	134.3	140.8	147.2	153.5	159.6	165.7
40	287	OUTPUT (MBH)	740.7	708.9	677.7	647.1	617.1	587.7	558.8	530.5	502.7	474.5
		COND. (lbs/hr)	796.8	762.5	728.9	695.9	663.6	631.9	600.9	570.4	540.5	511.1
		FAT (°F)	120.8	127.9	134.8	141.7	148.4	155.0	161.4	167.8	174.1	180.2
60	307	OUTPUT (MBH)	794.2	761.7	729.8	698.6	668.0	638.0	608.6	579.7	551.4	523.6
		COND. (lbs/hr)	869.5	833.8	798.8	764.6	731.1	698.2	665.9	634.4	603.2	572.8
		FAT (°F)	130.7	137.9	144.9	151.8	158.5	165.2	171.7	178.2	184.5	190.7
80	324	OUTPUT (MBH)	839.6	806.6	774.2	742.4	711.3	680.8	650.9	621.6	592.8	564.5
		COND. (lbs/hr)	931.7	894.9	858.9	823.6	789.0	755.1	721.9	689.3	657.3	625.9
		FAT (°F)	139.2	146.4	153.5	160.4	167.2	173.9	180.5	187.0	193.4	199.6
100	338	OUTPUT (MBH)	877.1	843.6	810.7	778.6	747.0	716.1	685.8	656.1	627.0	598.3
		COND. (lbs/hr)	985.5	947.7	910.7	874.5	839.0	804.2	770.1	736.7	703.9	671.7
		FAT (°F)	146.2	153.4	160.6	167.6	174.4	181.2	187.8	194.4	200.8	207.0

Refer to the Ruffneck™ HP model for service above 100 psi. For 50 Hz power supply, derate output by 10%.

Performance Data for FR1-36

ENTERING STEAM PARAMETERS		ENTERING AIR TEMPERATURE °F										
psig	°F		-10	0	10	20	30	40	50	60	70	80
2	219	OUTPUT (MBH)	935.4	886.2	837.9	790.6	744.2	698.6	653.8	609.9	566.7	524.2
		COND. (lbs/hr)	961.3	910.7	861.1	812.4	764.7	717.8	671.8	626.6	582.2	538.6
		FAT (°F)	85.4	92.3	99.2	105.9	112.5	119.0	125.4	131.6	137.8	143.9
10	239	OUTPUT (MBH)	1025.0	974.2	924.8	876.3	828.8	782.1	736.3	691.3	647.2	603.8
		COND. (lbs/hr)	1069.0	1016.0	964.4	913.8	864.2	815.5	767.7	720.8	674.7	619.5
		FAT (°F)	94.8	101.8	108.7	115.5	122.1	128.7	135.1	141.5	147.7	153.8
20	259	OUTPUT (MBH)	1114.0	1062.0	1012.0	962.3	913.6	866.0	819.1	773.2	728.0	683.7
		COND. (lbs/hr)	1177.0	1122.0	1069.0	1016.0	964.7	914.3	864.9	816.3	768.6	721.8
		FAT (°F)	104.3	111.4	118.3	125.2	131.9	138.5	145.0	151.4	157.6	163.8
40	287	OUTPUT (MBH)	1239.0	1186.0	1134.0	1083.0	1033.0	983.7	935.6	888.3	841.8	796.2
		COND. (lbs/hr)	1337.0	1279.0	1223.0	1168.0	1114.0	1061.0	1009.0	957.5	907.4	858.2
		FAT (°F)	117.7	124.9	131.9	138.9	145.7	152.4	158.9	165.4	171.8	178.0
60	307	OUTPUT (MBH)	1329.0	1275.0	1222.0	1169.0	1118.0	1068.0	1019.0	970.7	923.4	876.9
		COND. (lbs/hr)	1459.0	1399.0	1341.0	1283.0	1227.0	1172.0	1118.0	1065.0	1013.0	961.9
		FAT (°F)	127.4	134.6	141.7	148.7	155.6	162.4	169.0	175.5	181.9	188.2
80	324	OUTPUT (MBH)	1405.0	1350.0	1296.0	1243.0	1191.0	1140.0	1090.0	1041.0	992.8	945.6
		COND. (lbs/hr)	1563.0	1502.0	1442.0	1382.0	1325.0	1268.0	1212.0	1158.0	1104.0	1051.0
		FAT (°F)	135.7	143.0	150.1	157.2	164.1	170.9	177.6	184.2	190.7	197.0
100	338	OUTPUT (MBH)	1468.0	1412.0	1357.0	1303.0	1251.0	1199.0	1149.0	1099.0	1050.0	1002.0
		COND. (lbs/hr)	1654.0	1591.0	1529.0	1468.0	1409.0	1350.0	1293.0	1237.0	1182.0	1128.0
		FAT (°F)	142.5	149.9	157.1	164.2	171.2	178.0	184.7	191.4	197.9	204.3

Refer to the Ruffneck™ HP model for service above 100 psi.
Above figures are based on calculations at sea level and are intended as reference material only. Results may vary due to customer applications.

Specifications: FR1-12

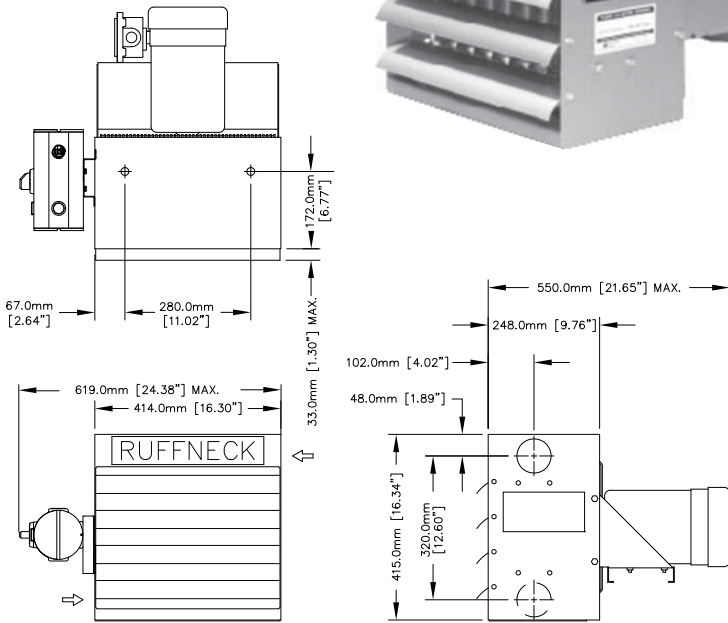

General

Air Delivery*	997 CFM
Air Velocity*	1147 FPM
Air Throw*	40 ft @ 15 psi stream
Propeller Fan	3 Wing Aluminum, 12" (305 mm) Dia. x 5/8" (16 mm) Bore
Motor Requirements	1/2 HP, 1725 RPM, Frame 56 Rigid Base (Specify enclosure type, voltage, cycle and phase.)
Fan Guard	Welded, Wire, Powder Coated Epoxy 1/4" (6 mm) probe will not enter.
Hanger Connections	5/8" (16 mm) NC Tap - 2 holes
Cabinet Material	0.075" (2 mm) steel
Louvre Blades	Anodized Extruded Aluminum
Net Weight	75 lbs (34 kg) \diamond *
Shipping Weight	102 lbs (46.3 kg) \diamond *

Heat Exchanger

Tube Outside Dia.	0.625" (16 mm)
Tube Wall Thickness	0.065" (1.65 mm) Average
Tube Material	SA 214 Carbon Steel
Fin Material	1050 Aluminum
Fins Per Inch	10
Number of Tubes	13
Number of Rows	2
Number of Passes	1
Header Material	Min. 0.075" (2 mm) Steel
Inlet/Outlet	2" NPT Female
Max. Operating Press.	100 psi
Max. Operating Temp.	572°F (300°C)

\diamond Add 12 lbs (5.4 kg) to flange units * Add 15 lbs (6.8 kg) to disconnect units

Specifications: FR1-16

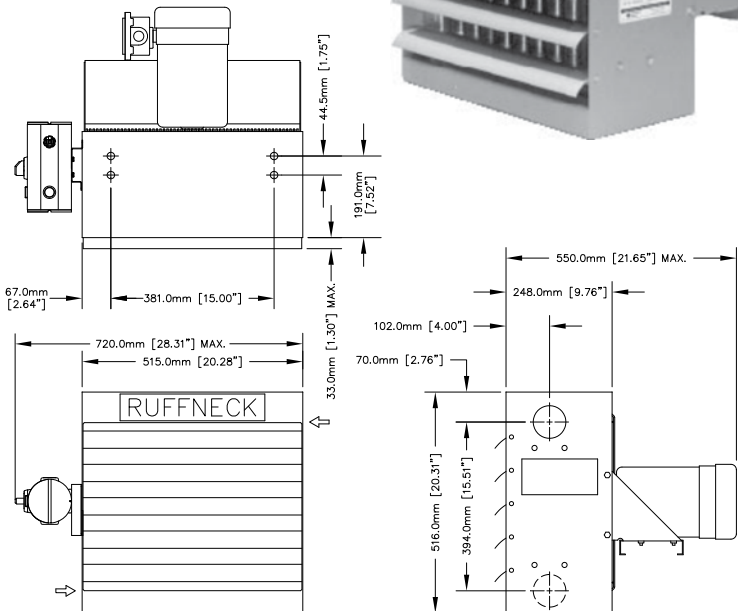

General

Air Delivery*	1588 CFM
Air Velocity*	1069 FPM
Air Throw*	60 ft @ 15 psi stream
Propeller Fan	3 Wing Aluminum, 16" (406 mm) Dia. x 5/8" (16 mm) Bore
Motor Requirements	1/2 HP, 1725 RPM, Frame 56 Rigid Base (Specify enclosure type, voltage, cycle and phase.)
Fan Guard	Welded, Wire, Powder Coated Epoxy 1/4" (6 mm) probe will not enter.
Hanger Connections	5/8" (16 mm) NC Tap - 4 holes
Cabinet Material	0.075" (2 mm) steel
Louvre Blades	Anodized Extruded Aluminum
Net Weight	109 lbs (49.4 kg) \diamond *
Shipping Weight	137 lbs (62.1 kg) \diamond *

Heat Exchanger

Tube Outside Dia.	0.625" (16 mm)
Tube Wall Thickness	0.065" (1.65 mm) Average
Tube Material	SA 214 Carbon Steel
Fin Material	1050 Aluminum
Fins Per Inch	10
Number of Tubes	17
Number of Rows	2
Number of Passes	1
Header Material	Min. 0.075" (2 mm) Steel
Inlet/Outlet	2" NPT Female
Max. Operating Press.	100 psi
Max. Operating Temp.	572°F (300°C)

\diamond Add 12 lbs (5.4 kg) to flange units * Add 15 lbs (6.8 kg) to disconnect units

FR

Specifications: FR1-20

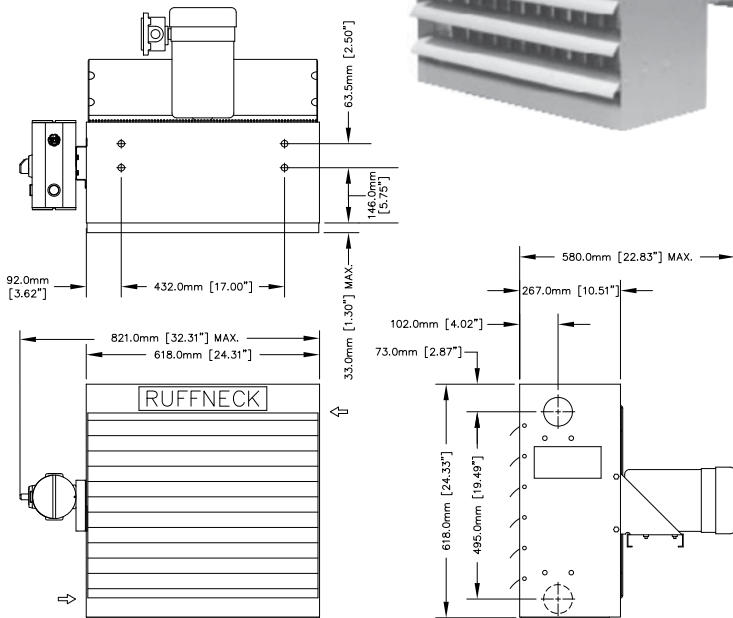

General

Air Delivery*	2780 CFM
Air Velocity*	1153 FPM
Air Throw*	65 ft @ 15 psi stream
Propeller Fan	3 Wing Aluminum, 20" (508 mm) Dia. x 5/8" (16 mm) Bore
Motor Requirements	1/2 HP, 1725 RPM, Frame 56 Rigid Base (Specify enclosure type, voltage, cycle and phase.)
Fan Guard	Welded, Wire, Powder Coated Epoxy 1/4" (6 mm) probe will not enter.
Hanger Connections	5/8" (16 mm) NC Tap - 4 holes
Cabinet Material	0.075" (2 mm) steel
Louvre Blades	Anodized Extruded Aluminum
Net Weight	138 lbs (62.6 kg) ◇ *
Shipping Weight	161 lbs (73 kg) ◇ *

Heat Exchanger

Tube Outside Dia.	0.625" (16 mm)
Tube Wall Thickness	0.065" (1.65 mm) Average
Tube Material	SA 214 Carbon Steel
Fin Material	1050 Aluminum
Fins Per Inch	10
Number of Tubes	21
Number of Rows	2
Number of Passes	1
Header Material	Min. 0.075" (2 mm) Steel
Inlet/Outlet	2" NPT Female
Max. Operating Press.	100 psi
Max. Operating Temp.	572°F (300°C)

◇ Add 12 lbs (5.4 kg) to flange units * Add 15 lbs (6.8 kg) to disconnect units

Specifications: FR1-24

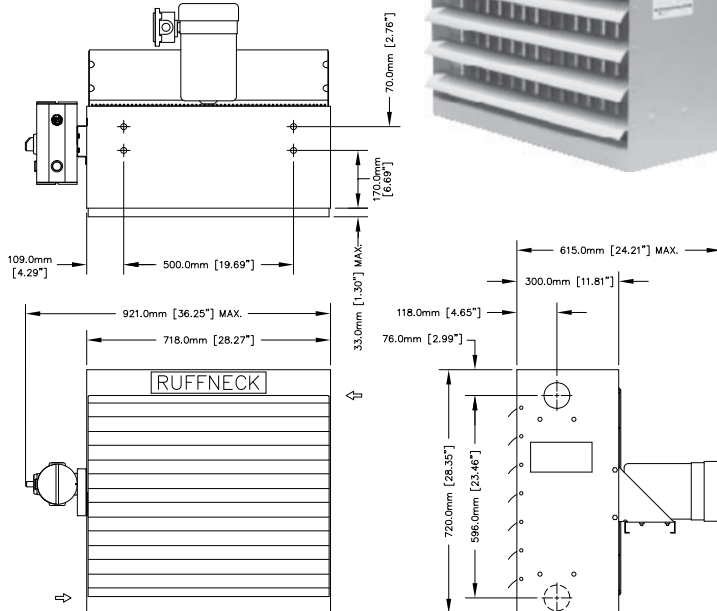

General

Air Delivery*	3405 CFM
Air Velocity*	981 FPM
Air Throw*	70 ft @ 15 psi stream
Propeller Fan	3 Wing Aluminum, 24" (610 mm) Dia. x 5/8" (16 mm) Bore
Motor Requirements	1/2 HP, 1725 RPM, Frame 56 Rigid Base (Specify enclosure type, voltage, cycle and phase.)
Fan Guard	Welded, Wire, Powder Coated Epoxy 7/16" (11 mm) probe will not enter.
Hanger Connections	5/8" (16 mm) NC Tap - 4 holes
Cabinet Material	0.075" (2 mm) steel
Louvre Blades	Anodized Extruded Aluminum
Net Weight	191 lbs (86.6 kg) ◇ *
Shipping Weight	224 lbs (101.6 kg) ◇ *

Heat Exchanger

Tube Outside Dia.	0.625" (16 mm)
Tube Wall Thickness	0.065" (1.65 mm) Average
Tube Material	SA 214 Carbon Steel
Fin Material	1050 Aluminum
Fins Per Inch	10
Number of Tubes	38
Number of Rows	3
Number of Passes	1
Header Material	Min. 0.075" (2 mm) Steel
Inlet/Outlet	2" NPT Female
Max. Operating Press.	100 psi
	100 psi for CSA Certified Steam Heaters
Max. Operating Temp.	572°F (300°C)

* at 70°F (21°C) at sea level

◇ Add 12 lbs (5.4 kg) to flange units * Add 15 lbs (6.8 kg) to disconnect units

FR

Heat Exchanger Unit Heaters

CCI Thermal Technologies Inc. 

63

**Specifications:
FR1-30**

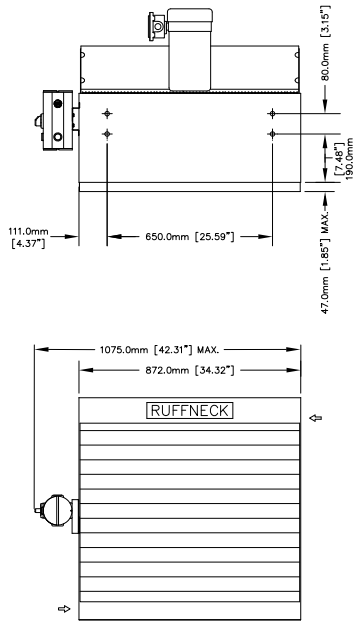

General

Air Delivery*	4569 CFM
Air Velocity*	814 FPM
Air Throw*	70 ft @ 15 psi stream
Propeller Fan	3 Wing Aluminum, 30" (762 mm) Dia. x 5/8" (16 mm) Bore
Motor Requirements	3/4 HP, 1140 RPM, Frame 56 Rigid Base (Specify enclosure type, voltage, cycle and phase.)
Fan Guard	Welded, Wire, Powder Coated Epoxy 7/16" (11 mm) probe will not enter.
Hanger Connections	5/8" (16 mm) NC Tap - 4 holes
Cabinet Material	0.075" (2 mm) steel
Louvre Blades	Anodized Extruded Aluminum
Net Weight	286 lbs (121.6 kg) ◇ *
Shipping Weight	345 lbs (156.5 kg) ◇ *

Heat Exchanger

Tube Outside Dia.	0.625" (16 mm)
Tube Wall Thickness	0.065" (1.65 mm) Average
Tube Material	SA 214 Carbon Steel
Fin Material	1050 Aluminum
Fins Per Inch	10
Number of Tubes	47
Number of Rows	3
Number of Passes	1
Header Material	Min. 0.075" (2 mm) Steel
Inlet/Outlet	2" NPT Female
Max. Operating Press.	100 psi 80 psi for CSA Certified Steam Heaters
Max. Operating Temp.	572°F (300°C)

◇ Add 12 lbs (5.4 kg) to flange units * Add 15 lbs (6.8 kg) to disconnect units

**Specifications:
FR1-36**

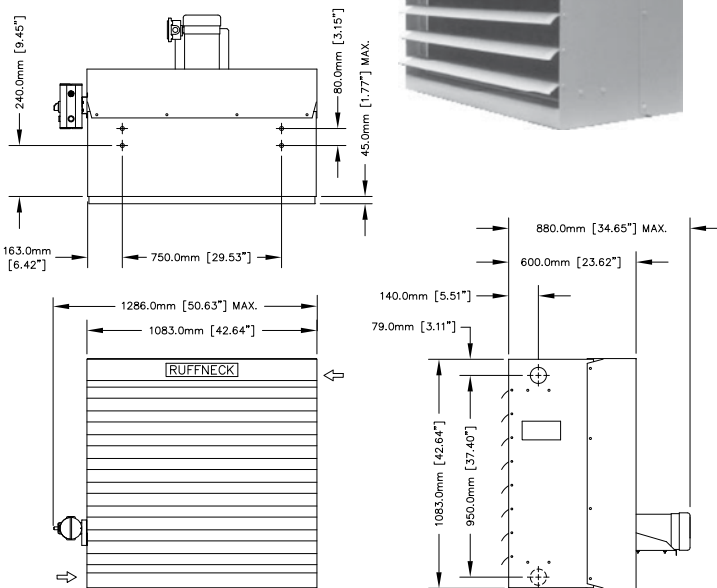

General

Air Delivery*	7830 CFM
Air Velocity*	852 FPM
Air Throw*	65 ft @ 15 psi stream
Propeller Fan	6 Wing Aluminum, 36" (914 mm) Dia. x 1" (25mm) Bore
Motor Requirements	1½ HP, 1725 RPM, Frame 56 Rigid Base (Specify enclosure type, voltage, cycle and phase.)
Drive Pulley	B3.6"
Driven Pulley	B9.9"
Drive Belt	B42 V-Belt
Fan Speed	627 RPM
Fan Guard	Steel, Powder Coated Epoxy, 1/2" (13 mm) gap
Hanger Connections	5/8" (16 mm) NC Tap - 4 holes
Cabinet Material	0.105" (2.66 mm) steel
Louvre Blades	Anodized Extruded Aluminum
Net Weight	534 lbs (242.2 kg) ◇ *
Shipping Weight	597 lbs (270.8 kg) ◇ *

Heat Exchanger

Tube Outside Dia.	0.625" (16 mm)
Tube Wall Thickness	0.065" (1.65 mm) Average
Tube Material	SA 214 Carbon Steel
Fin Material	1050 Aluminum
Fins Per Inch	10
Number of Tubes	59
Number of Rows	3
Number of Passes	1
Header Material	Min. 0.075" (2 mm) Steel
Inlet/Outlet	2" NPT Female
Max. Operating Press.	100 psi 85 psi for CSA Certified Steam Heaters
Max. Operating Temp.	572°F (300°C)

◇ Add 12 lbs (5.4 kg) to flange units * Add 15 lbs (6.8 kg) to disconnect units

* at 70°F (21°C) at sea level

FR



HP Heat Exchanger Unit Heater

Ruffneck™ HP Heat Exchanger Unit Heaters are extra heavy duty (including heavy gauge steel construction) to meet the most demanding service and long life requirements for rugged industrial applications, such as space heating and liquid cooling. The HP Series heaters are suitable for a wide range of heating fluids including steam, hot water, glycol, oil, etc.. Explosion-proof models suitable for hazardous locations are available on custom order.

Engineered for ease of maintenance, all parts are easily removed. All fasteners are plated capscrews; no sheet metal screws are used. Heat exchanger cores are of steel construction with tension wound, close fitting aluminium fins. They are resistant to corrosive agents (including hydrogen sulphide).

All units are equipped with a narrow-gap, epoxy coated fan guard. Choose from several optional UL listed and/or CSA approved motors with various voltages, phases and frequencies. All HP models have Canadian CRN approvals and are CSA certified for hazardous locations: Class I, Divisions 1 & 2, Groups C & D; Class II, Division 1 & 2, Groups E, F, & G; Class III, Division 1 & 2; Temperature Code T3B 329°F (165°C) - (on applicable models only).

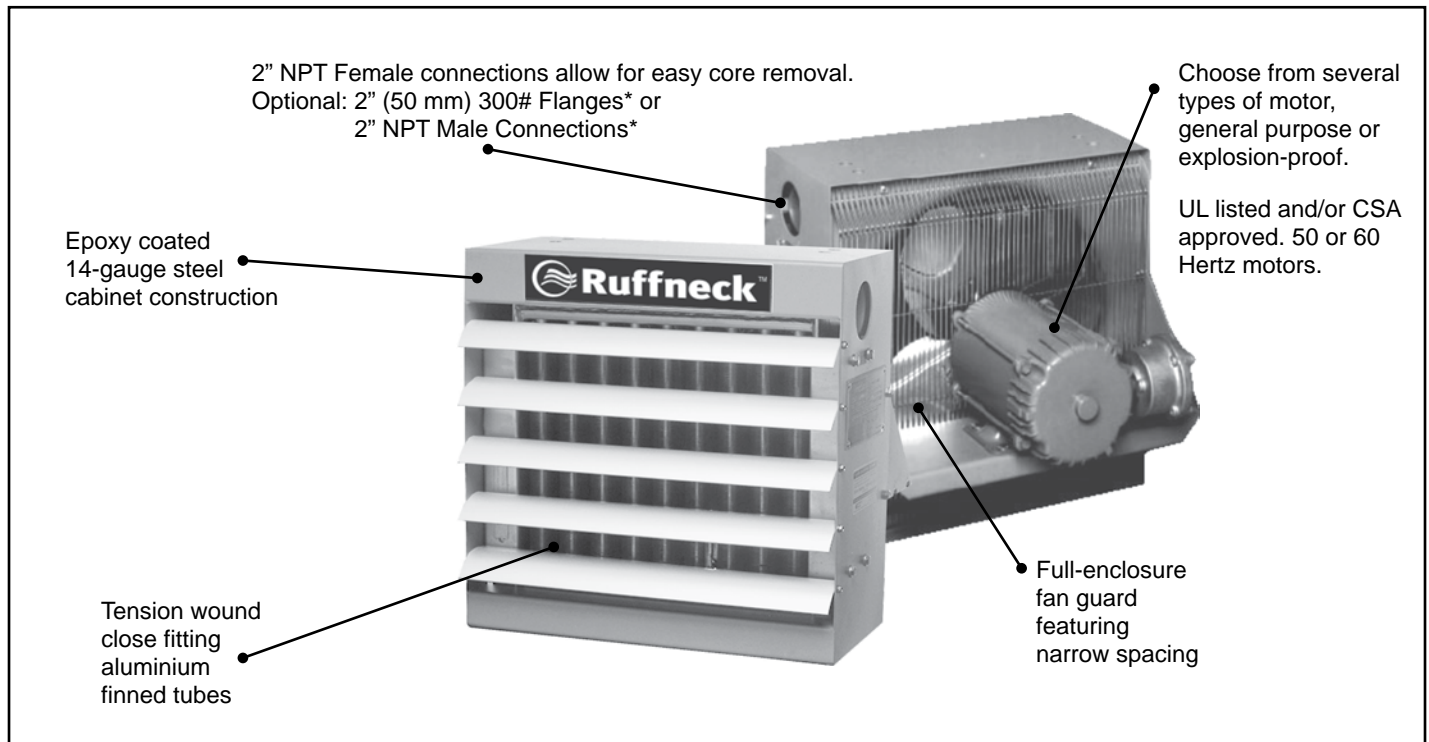

Heresite® is a registered trademark of Heresite® Protective Coatings Inc.
* 2" 300# Flanges and 2" NPT Male Connections increase difficulty in core removal.

Model Coding

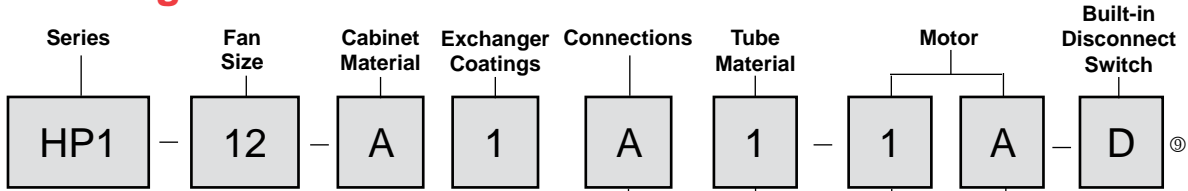

FAN SIZE	MODEL & SIZE
HP1-12 THRU HP1-36	1 - Pass HP1
HP3-12 THRU HP3-36	3 - Pass HP3
HP5-16 THRU HP5-36	5 - Pass HP5
HP7-24 THRU HP7-36	7 - Pass HP7

FAN SIZE	
12" DIA	12
16" DIA	16
20" DIA	20
24" DIA	24
30" DIA	30
36" DIA	36

CABINET MATERIAL	
EPOXY POWDER COATED CARBON STEEL	A
HERESITE® PHENOLIC COATED CARBON STEEL	B
STAINLESS STEEL	C

EXCHANGER COATINGS	
HEAT RESISTANT ALUMINUM PAINT	1
HERESITE® PHENOLIC COATING	2

CONNECTIONS	
2" NPT FEMALE	A
2" NPT MALE, SCH. 80	B
2" 300# RF FLANGE	C

MOTOR ELECTRICAL SPECIFICATIONS			
	VOLTS	PHASE	HERTZ
A	115	1	60
B	208	1	60
C	208	3	60
D	230	1	60
E	230	3	60
F	460	1	60
G	460	3	60
I	220	1	50
J	380	3	50
K	440	3	50

HEATER CERTIFICATION	
1	General Purpose
2	X-proof, groups C, D, E, F, & G
3	CSA Certified Heater

TUBE MATERIAL						
	WALL THICKNESS	ROWS	FINNING			TUBING
			FINS/ INCH	MATERIAL	TYPE	
A	.065" (1.7 mm)	3	10	AL	TW	5/8" (16 mm)

TW = Tension Wound
EX = Extruded
AL = Aluminum

NOTE:

Ruffneck™ utilizes Doerr/Emerson/Baldor as our standard motor. Specifying any other O.E.M. motor may result in longer lead times. All heat exchangers are registered to C.R.N. OH0224.2C.

They are approved for use in all provinces and territories in Canada.

- ① Heresite® coated exchangers and cabinets: contact factory for quote.
- ② Louvres and fan blades are also Heresite® coated.
- ③ Contact factory for shipping lead time.
- ④ Motor designed to be used at rated voltage with tolerances of ±15%.
- ⑤ Motor may be marked 230V, but is suitable for 208V operation.
- ⑥ 460 1 phase motors are only certified for groups D, F & G.
- ⑦ Only available in 16" and larger units.
- ⑧ Only available in 24" and larger units.
- ⑨ Built-in Disconnect only available with CSA certified heaters.

HP Single-Pass & Multi-Pass

The HP (High Pressure) Series is for steam and liquid service up to 400 psi (on select models).

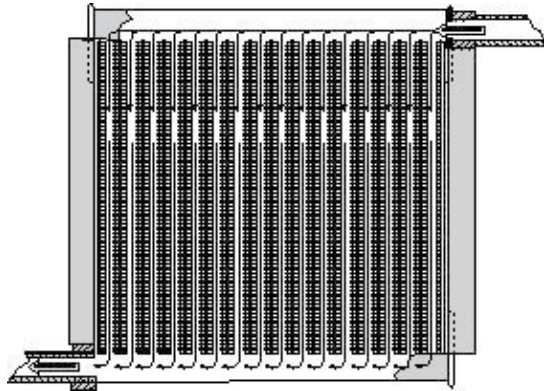

Single-Pass for HP Series

Typical single-pass heat exchanger configurations are available HP series units. Note that the fluid flow is divided among all tubes. This is best suited to steam and high flow rate liquid applications.

Optional Built-in Disconnect available.

The Ruffneck™ Disconnect Switch is engineered for use in the most demanding applications such as drilling rigs, utilidors and compression stations where high vibration, dirt, moisture, fluctuating power and high impact conditions exist. The Built-in Disconnect Switch is available on all Ruffneck™ HP heaters.

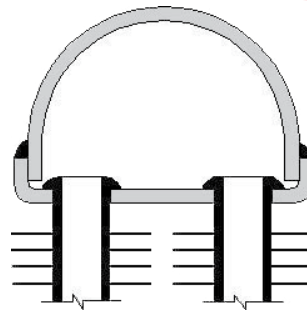

HP Series Heater Shape

Available in one, three, five and seven pass configurations depending on model. Pressure up to 400 psi. Operating pressure on select models.

The HP Series is designed for pressures up to 400 psi (on select models). These units have semicircular headers that can withstand high operating pressures for steam or liquid service. The HP series is available in single-pass and multi-pass configurations. Single-pass units are desirable for high flow rate liquid service requiring a low pressure drop or for steam applications. Multi-pass units are intended for liquid service only. They are baffled in the top and bottom headers such that the heat transfer liquid will flow through groups of tubes in series within the core. This causes the liquid to travel a longer distance at a higher velocity, thereby increasing the heat transfer rate due to increased turbulence. Units with the greatest number of tube-side passes will always have the highest heat output, but will also have the highest pressure drop. Depending on the application, an HP model in a one, three, five, or seven pass core configuration may be recommended.

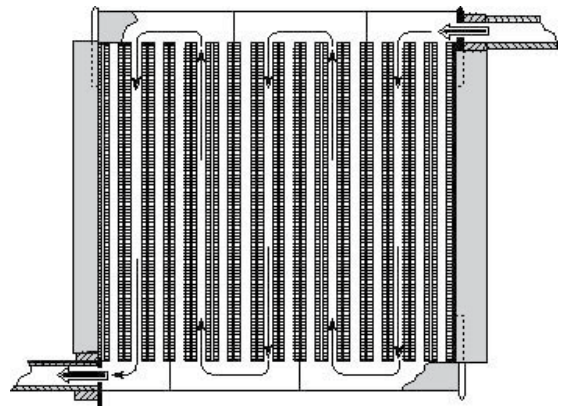

Multi-pass for HP Series

Note that the flow is baffled into groups of tubes to increase fluid velocity and thermal efficiency. Suitable for liquid service only.

Performance Data for HP1-12

ENTERING STEAM PARAMETERS		ENTERING AIR TEMPERATURE °F										
psig	°F		-10	0	10	20	30	40	50	60	70	80
2	219	OUTPUT (MBH)				57.3	54.1	50.8	47.7	44.6	41.5	38.4
		COND. (lbs/hr)	-	-	-	57.9	54.6	51.4	48.2	45.0	41.9	38.8
		FAT (°F)				67.4	75.7	83.8	91.9	100.0	107.9	115.8
10	239	OUTPUT (MBH)				63.7	60.4	57.1	53.8	50.6	47.5	44.4
		COND. (lbs/hr)	-	-	-	65.3	61.8	58.5	55.2	51.9	48.7	45.5
		FAT (°F)				72.7	81.0	89.3	97.4	105.5	113.5	121.4
20	259	OUTPUT (MBH)			73.6	70.1	66.7	63.3	60.0	56.8	53.6	50.4
		COND. (lbs/hr)	-	-	76.3	72.7	69.2	65.7	62.3	58.9	55.5	52.3
		FAT (°F)			69.7	78.1	86.5	94.7	102.9	111.0	119.1	127.1
40	287	OUTPUT (MBH)		86.3	82.7	79.1	75.6	72.2	68.8	65.4	62.2	58.9
		COND. (lbs/hr)	-	91.4	87.5	83.8	80.0	76.4	72.8	69.2	65.7	62.3
		FAT (°F)		68.7	77.2	85.7	94.1	102.5	110.7	118.9	127.0	135.1
60	307	OUTPUT (MBH)	96.7	92.9	89.3	85.6	82.1	78.6	75.1	71.7	68.3	65.0
		COND. (lbs/hr)	104.2	100.1	96.1	92.2	88.3	84.5	80.8	77.1	73.5	69.9
		FAT (°F)	65.4	74.0	82.7	91.2	99.7	108.0	116.3	124.6	132.7	140.8
80	324	OUTPUT (MBH)	102.4	98.6	94.9	91.2	87.5	84.0	80.5	77.0	73.6	70.2
		COND. (lbs/hr)	111.8	107.6	103.5	99.4	95.5	91.6	87.7	83.9	80.2	76.5
		FAT (°F)	69.9	78.6	87.3	95.9	104.4	112.8	121.2	129.4	137.6	145.8
100	338	OUTPUT (MBH)	107.1	103.3	99.5	95.7	92.1	88.5	84.9	81.4	77.9	74.5
		COND. (lbs/hr)	118.3	114.1	109.8	105.7	101.6	97.6	93.7	89.8	86.0	82.2
		FAT (°F)	73.6	82.4	91.1	99.7	108.3	116.8	125.1	133.5	141.7	149.9
150	366	OUTPUT (MBH)	116.6	112.6	108.8	104.9	101.2	97.5	93.8	90.3	86.7	83.3
		COND. (lbs/hr)	132.2	127.7	123.3	118.9	114.6	110.4	106.3	102.2	98.2	94.2
		FAT (°F)	81.2	90.1	98.8	107.5	116.2	124.7	133.2	141.6	149.9	158.1
200	387	OUTPUT (MBH)	123.7	119.7	115.8	111.9	108.0	104.3	100.6	96.9	93.3	89.8
		COND. (lbs/hr)	143.3	138.6	134.0	129.5	125.0	120.7	116.3	112.1	107.9	103.8
		FAT (°F)	86.9	95.8	104.7	113.4	122.1	130.7	139.2	147.7	156.0	164.3
250	406	OUTPUT (MBH)	130.2	126.1	122.1	118.1	114.3	110.4	106.7	103.0	99.3	95.8
		COND. (lbs/hr)	154.1	149.2	144.4	139.7	135.1	130.5	126.0	121.6	117.3	113.0
		FAT (°F)	92.1	101.0	109.9	118.8	127.5	136.2	144.7	153.2	161.7	170.0

For applications over 250 psi, please contact the factory. For 50 Hz power supply, derate output by 10%

Performance Data for HP1-16

ENTERING STEAM PARAMETERS		ENTERING AIR TEMPERATURE °F										
psig	°F		-10	0	10	20	30	40	50	60	70	80
2	219	OUTPUT (MBH)				95.3	89.8	84.5	79.2	74.0	68.9	63.8
		COND. (lbs/hr)	-	-	-	96.8	91.2	85.8	80.4	75.2	70.0	64.8
		FAT (°F)				69.8	77.9	86.0	94.0	101.9	109.8	117.6
10	239	OUTPUT (MBH)			111.5	105.8	100.3	94.8	89.4	84.1	78.9	73.7
		COND. (lbs/hr)	-	-	114.8	109.0	103.3	97.6	92.1	86.6	81.2	75.9
		FAT (°F)			67.1	75.3	83.5	91.7	99.7	107.7	115.6	123.4
20	259	OUTPUT (MBH)			122.2	116.4	110.7	105.2	99.7	94.2	88.9	83.6
		COND. (lbs/hr)	-	-	127.4	121.4	115.5	109.6	103.9	98.2	92.7	87.2
		FAT (°F)			72.7	81.0	89.2	97.4	105.5	113.5	121.4	129.3
40	287	OUTPUT (MBH)		143.3	137.3	131.4	125.5	119.8	114.1	108.5	103.1	97.6
		COND. (lbs/hr)	-	152.6	146.1	139.8	133.6	127.4	121.4	115.5	109.6	103.9
		FAT (°F)		72.1	80.5	88.9	97.2	105.5	113.6	121.7	129.7	137.7
60	307	OUTPUT (MBH)	160.5	154.3	148.1	142.1	136.1	130.3	124.5	118.8	113.2	107.7
		COND. (lbs/hr)	173.9	167.1	160.4	153.9	147.4	141.0	134.8	128.6	122.6	116.6
		FAT (°F)	69.1	77.7	86.2	94.7	103.0	111.3	119.5	127.7	135.7	143.7
80	324	OUTPUT (MBH)	170.0	163.6	157.4	151.2	145.2	139.2	133.4	127.6	121.9	116.4
		COND. (lbs/hr)	186.6	179.6	172.7	165.9	159.3	152.7	146.2	140.0	133.7	127.6
		FAT (°F)	73.8	82.5	91.1	99.6	108.0	116.3	124.6	132.7	140.8	148.9
100	338	OUTPUT (MBH)	177.8	171.3	165.0	158.8	152.7	146.6	140.7	134.9	129.1	123.5
		COND. (lbs/hr)	197.6	190.4	183.3	176.4	169.5	162.8	156.2	149.7	143.3	137.0
		FAT (°F)	77.8	86.5	95.1	103.6	112.1	120.4	128.7	136.9	145.1	153.1
150	366	OUTPUT (MBH)	193.4	186.8	180.3	173.9	167.7	161.5	155.4	149.5	143.6	137.8
		COND. (lbs/hr)	220.6	213.0	205.6	198.3	191.1	184.1	177.1	170.3	163.6	157.0
		FAT (°F)	85.7	94.4	103.1	111.8	120.3	128.7	137.1	145.4	153.6	161.8
200	387	OUTPUT (MBH)	205.1	198.4	191.8	185.3	179.0	172.7	166.5	160.4	154.5	148.6
		COND. (lbs/hr)	239.2	231.3	223.6	216.0	208.5	201.1	194.0	186.8	179.8	172.9
		FAT (°F)	91.6	100.5	109.2	117.9	126.5	135.0	143.5	151.8	160.1	168.3
250	406	OUTPUT (MBH)	215.8	209.0	202.3	195.7	189.2	182.9	176.6	170.4	164.4	158.4
		COND. (lbs/hr)	257.0	248.8	240.8	232.9	225.2	217.5	210.1	202.7	195.4	188.3
		FAT (°F)	97.0	106.0	114.8	123.5	132.2	140.7	149.2	157.6	166.0	174.2

Above figures are based on calculations at sea level and are intended as reference material only. Results may vary due to customer applications.

Performance Data for HP1-20

ENTERING STEAM PARAMETERS		ENTERING AIR TEMPERATURE °F										
psig	°F		-10	0	10	20	30	40	50	60	70	80
2	219	OUTPUT (MBH)	-	-	-	161.1	151.9	142.9	134.0	125.2	116.5	108.0
		COND. (lbs/hr)	-	-	-	164.4	155.0	145.8	136.7	127.8	119.0	110.2
		FAT (°F)	-	-	-	68.3	76.5	84.6	92.7	100.7	108.6	116.5
10	239	OUTPUT (MBH)	-	-	188.4	178.9	169.5	160.3	151.2	142.2	133.4	124.7
		COND. (lbs/hr)	-	-	195.2	185.3	175.6	166.0	156.6	147.3	138.1	129.7
		FAT (°F)	-	-	65.4	73.7	82.0	90.1	98.3	106.3	114.3	122.2
20	259	OUTPUT (MBH)	-	-	206.6	196.9	187.3	177.9	168.6	159.4	150.4	141.5
		COND. (lbs/hr)	-	-	216.7	206.4	196.4	186.5	176.7	167.1	157.7	148.3
		FAT (°F)	-	-	70.8	79.2	87.5	95.7	103.9	112.0	120.0	128.0
40	287	OUTPUT (MBH)	-	242.3	232.2	222.2	212.3	202.6	193.0	183.7	174.4	165.3
		COND. (lbs/hr)	-	259.4	148.5	237.8	227.2	216.8	206.6	196.5	186.6	176.8
		FAT (°F)	-	69.9	78.5	86.9	95.3	103.6	111.8	120.0	128.0	
60	307	OUTPUT (MBH)	271.4	260.9	250.5	240.3	230.3	220.4	210.7	201.1	191.6	182.3
		COND. (lbs/hr)	295.7	284.2	272.9	261.7	250.8	240.0	229.4	218.9	208.6	198.5
		FAT (°F)	66.7	75.4	84.0	92.5	100.9	109.3	117.5	125.7	133.9	141.9
80	324	OUTPUT (MBH)	287.4	276.7	266.1	255.8	245.6	235.6	225.7	216.0	206.4	196.9
		COND. (lbs/hr)	317.4	305.5	293.8	282.3	271.1	260.0	249.0	238.3	227.7	217.3
		FAT (°F)	71.4	80.1	88.7	97.3	105.7	114.1	122.4	130.7	138.9	146.9
100	338	OUTPUT (MBH)	300.6	289.7	279.1	268.6	258.2	248.1	238.1	228.2	218.5	209.0
		COND. (lbs/hr)	336.0	323.9	311.9	300.1	288.6	277.2	266.0	255.0	244.1	233.4
		FAT (°F)	75.2	83.9	92.6	101.2	109.7	118.1	126.5	134.8	143.0	151.1
150	366	OUTPUT (MBH)	327.0	315.9	305.0	294.2	283.6	273.2	263.0	252.9	243.0	233.2
		COND. (lbs/hr)	375.4	362.6	350.0	337.6	325.4	313.5	301.7	290.1	278.7	267.4
		FAT (°F)	82.9	91.7	100.5	109.1	117.7	126.2	134.7	143.0	151.3	159.5
200	387	OUTPUT (MBH)	346.9	335.6	324.5	313.5	302.8	292.2	281.8	271.5	261.4	251.5
		COND. (lbs/hr)	407.1	398.7	380.6	367.7	355.0	342.6	330.3	318.3	306.4	294.7
		FAT (°F)	88.7	97.6	106.4	115.1	123.8	132.3	140.8	149.3	157.6	165.8
250	406	OUTPUT (MBH)	365.0	353.4	342.1	331.1	320.1	309.4	298.8	288.4	278.1	268.0
		COND. (lbs/hr)	437.5	423.6	410.0	396.6	383.5	370.6	357.9	345.3	333.0	320.9
		FAT (°F)	93.9	102.9	111.8	120.6	129.3	137.9	146.5	154.9	163.3	171.6

For applications over 250 psi, please contact the factory. For 50 Hz power supply, derate output by 10%.

Performance Data for HP1-24

ENTERING STEAM PARAMETERS		ENTERING AIR TEMPERATURE °F										
psig	°F		-10	0	10	20	30	40	50	60	70	80
2	219	OUTPUT (MBH)	384.4	364.4	344.7	325.4	306.4	287.7	269.4	251.4	233.7	216.3
		COND. (lbs/hr)	393.6	373.0	352.8	333.0	313.6	294.5	275.7	257.3	239.2	221.3
		FAT (°F)	79.7	86.0	93.9	100.9	107.7	114.4	121.1	127.6	134.0	140.3
10	239	OUTPUT (MBH)	421.4	400.9	380.7	360.9	341.5	322.4	303.6	285.2	267.1	249.3
		COND. (lbs/hr)	437.8	416.4	395.4	374.9	354.7	334.8	315.3	296.2	277.4	258.8
		FAT (°F)	88.6	95.8	103.0	110.0	116.9	123.6	130.3	136.9	143.4	149.7
20	259	OUTPUT (MBH)	458.5	437.5	416.9	396.6	376.7	357.2	338.1	319.2	300.7	282.5
		COND. (lbs/hr)	482.3	460.1	438.4	417.1	396.2	375.6	355.4	335.6	316.1	297.0
		FAT (°F)	97.6	104.9	112.1	119.1	126.1	132.9	139.7	146.3	152.8	159.2
40	287	OUTPUT (MBH)	510.6	488.9	467.6	446.8	426.3	406.2	386.5	367.1	348.0	329.3
		COND. (lbs/hr)	548.3	525.0	502.1	479.7	457.6	436.0	414.8	394.0	373.5	353.4
		FAT (°F)	110.3	117.7	125.0	132.1	139.2	146.1	152.9	159.6	166.2	172.7
60	307	OUTPUT (MBH)	547.8	525.7	504.0	482.7	461.8	441.3	421.2	401.1	382.0	362.9
		COND. (lbs/hr)	598.7	574.5	550.7	527.4	504.5	482.0	460.0	438.4	417.2	396.3
		FAT (°F)	119.5	127.0	134.3	141.5	148.6	155.6	162.5	169.2	175.9	182.4
80	324	OUTPUT (MBH)	579.5	557.0	534.9	513.3	492.1	471.2	450.8	430.7	410.9	391.5
		COND. (lbs/hr)	641.9	616.9	592.4	568.4	544.8	521.7	499.0	476.7	454.8	433.3
		FAT (°F)	127.3	134.8	142.2	149.5	156.7	163.7	170.6	177.5	184.2	190.8
100	338	OUTPUT (MBH)	605.7	582.8	560.5	538.5	517.0	495.9	475.2	454.8	434.8	415.2
		COND. (lbs/hr)	679.3	653.6	628.4	603.8	579.6	555.8	532.5	509.7	487.2	465.2
		FAT (°F)	133.8	141.4	148.8	156.2	163.4	170.4	177.4	184.3	191.0	197.7
150	366	OUTPUT (MBH)	658.0	634.6	611.6	589.1	567.0	545.4	524.1	503.2	482.7	462.6
		COND. (lbs/hr)	757.8	730.7	704.2	678.2	652.7	627.7	603.2	579.1	555.4	532.2
		FAT (°F)	146.9	154.5	162.1	169.5	176.8	184.0	191.1	198.0	204.9	211.6
200	387	OUTPUT (MBH)	697.3	673.4	650.0	627.1	604.6	582.5	560.9	539.6	518.8	498.3
		COND. (lbs/hr)	820.9	792.7	765.0	737.9	711.4	685.3	659.8	634.7	610.0	585.9
		FAT (°F)	156.7	164.5	172.1	179.6	187.0	194.3	201.4	208.4	215.4	222.1
250	406	OUTPUT (MBH)	732.9	708.6	684.8	661.5	638.6	616.2	594.2	572.6	551.4	530.6
		COND. (lbs/hr)	881.5	852.2	823.5	795.3	767.7	740.7	714.1	688.1	662.5	637.4
		FAT (°F)	165.7	173.5	181.3	188.8	196.3	203.6	210.8	217.9	224.9	231.8

Above figures are based on calculations at sea level and are intended as reference material only. Results may vary due to customer applications.

Performance Data for HP1-30

ENTERING STEAM PARAMETERS		ENTERING AIR TEMPERATURE °F										
psig	°F		-10	0	10	20	30	40	50	60	70	80
2	219	OUTPUT (MBH)	559.5	530.0	501.1	472.7	444.9	417.6	390.8	364.5	338.6	331.2
		COND. (lbs/hr)	573.7	543.4	513.7	484.6	456.1	428.1	400.6	373.6	347.1	321.0
		FAT (°F)	87.7	94.6	101.3	107.9	114.4	120.8	127.1	133.3	139.4	145.4
10	239	OUTPUT (MBH)	612.7	582.5	552.9	523.8	495.4	467.4	440.0	413.1	386.7	360.7
		COND. (lbs/hr)	637.5	606.0	575.2	544.9	515.3	486.2	457.7	429.7	402.1	375.1
		FAT (°F)	97.4	104.3	111.1	117.8	124.3	130.8	137.1	143.3	149.5	155.5
20	259	OUTPUT (MBH)	666.0	635.1	604.8	575.1	546.0	517.4	489.4	461.9	434.9	408.4
		COND. (lbs/hr)	701.7	669.1	637.1	605.8	575.1	545.0	515.4	486.4	458.0	430.0
		FAT (°F)	107.1	114.1	120.9	127.7	134.3	140.8	147.2	153.5	159.6	165.7
40	287	OUTPUT (MBH)	740.7	708.9	677.7	647.1	617.1	587.7	558.8	530.5	502.7	474.5
		COND. (lbs/hr)	796.8	762.5	728.9	695.9	663.6	631.9	600.9	570.4	540.5	511.1
		FAT (°F)	120.8	127.9	134.8	141.7	148.4	155.0	161.4	167.8	174.1	180.2
60	307	OUTPUT (MBH)	794.2	761.7	729.8	698.6	668.0	638.0	608.6	579.7	551.4	523.6
		COND. (lbs/hr)	869.5	833.8	798.8	764.6	731.1	698.2	665.9	634.4	603.2	572.8
		FAT (°F)	130.7	137.9	144.9	151.8	158.5	165.2	171.7	178.2	184.5	190.7
80	324	OUTPUT (MBH)	839.6	806.6	774.2	742.4	711.3	680.8	650.9	621.6	592.8	564.5
		COND. (lbs/hr)	931.7	894.9	858.9	823.6	789.0	755.1	721.9	689.3	657.3	625.9
		FAT (°F)	139.2	146.4	153.5	160.4	167.2	173.9	180.5	187.0	193.4	199.6
100	338	OUTPUT (MBH)	877.1	843.6	810.7	778.6	747.0	716.1	685.8	656.1	627.0	598.3
		COND. (lbs/hr)	985.5	947.7	910.7	874.5	839.0	804.2	770.1	736.7	703.9	671.7
		FAT (°F)	146.2	153.4	160.6	167.6	174.4	181.2	187.8	194.4	200.8	207.0
150	366	OUTPUT (MBH)	952.0	917.6	883.9	850.9	818.6	786.9	755.8	725.3	695.4	666.1
		COND. (lbs/hr)	1099.0	1059.0	1020.0	981.5	944.1	907.4	871.5	836.3	801.7	767.8
		FAT (°F)	160.3	167.6	174.9	182.0	189.0	195.8	202.5	209.2	215.7	222.0
200	387	OUTPUT (MBH)	1008.0	973.2	938.9	905.2	872.3	840.0	808.4	777.3	746.9	717.0
		COND. (lbs/hr)	1189.0	1148.0	1107.0	1067.0	1028.0	990.2	952.8	916.1	880.1	844.8
		FAT (°F)	170.9	178.4	185.7	192.9	199.9	206.8	213.7	220.3	226.9	233.4
250	406	OUTPUT (MBH)	1059.0	1024.0	988.6	954.4	920.9	888.1	855.9	824.4	793.5	763.1
		COND. (lbs/hr)	1277.0	1233.0	1191.0	1150.0	1109.0	1070.0	1031.0	992.7	955.3	918.7
		FAT (°F)	180.6	188.1	195.5	202.8	209.9	216.9	223.8	230.5	237.2	243.7

For applications over 250 psi, please contact the factory. For 50 Hz power supply, derate output by 10%.

Performance Data for HP1-36

ENTERING STEAM PARAMETERS		ENTERING AIR TEMPERATURE °F										
psig	°F		-10	0	10	20	30	40	50	60	70	80
2	219	OUTPUT (MBH)	935.4	886.2	837.9	790.6	744.2	698.6	653.8	609.9	566.7	524.2
		COND. (lbs/hr)	961.3	910.7	861.1	812.4	764.7	717.8	671.8	626.6	582.2	538.6
		FAT (°F)	85.4	92.3	99.2	105.9	112.5	119.0	125.4	131.6	137.8	143.9
10	239	OUTPUT (MBH)	1025.0	974.2	924.8	876.3	828.8	782.1	736.3	691.3	647.2	603.8
		COND. (lbs/hr)	1069.0	1016.0	964.4	913.8	864.2	815.5	767.7	720.8	674.7	619.5
		FAT (°F)	94.8	101.8	108.7	115.5	122.1	128.7	135.1	141.5	147.7	153.8
20	259	OUTPUT (MBH)	1114.0	1062.0	1012.0	962.3	913.6	866.0	819.1	773.2	728.0	683.7
		COND. (lbs/hr)	1177.0	1122.0	1069.0	1016.0	964.7	914.3	864.9	816.3	768.6	721.8
		FAT (°F)	104.3	111.4	118.3	125.2	131.9	138.5	145.0	151.4	157.6	163.8
40	287	OUTPUT (MBH)	1239.0	1186.0	1134.0	1083.0	1033.0	983.7	935.6	888.3	841.8	796.2
		COND. (lbs/hr)	1337.0	1279.0	1223.0	1168.0	1114.0	1061.0	1009.0	957.5	907.4	858.2
		FAT (°F)	117.7	124.9	131.9	138.9	145.7	152.4	158.9	165.4	171.8	178.0
60	307	OUTPUT (MBH)	1329.0	1275.0	1222.0	1169.0	1118.0	1068.0	1019.0	970.7	923.4	876.9
		COND. (lbs/hr)	1459.0	1399.0	1341.0	1283.0	1227.0	1172.0	1118.0	1065.0	1013.0	961.9
		FAT (°F)	127.4	134.6	141.7	148.7	155.6	162.4	169.0	175.5	181.9	188.2
80	324	OUTPUT (MBH)	1405.0	1350.0	1296.0	1243.0	1191.0	1140.0	1090.0	1041.0	992.8	945.6
		COND. (lbs/hr)	1563.0	1502.0	1442.0	1382.0	1325.0	1268.0	1212.0	1158.0	1104.0	1051.0
		FAT (°F)	135.7	143.0	150.1	157.2	164.1	170.9	177.6	184.2	190.7	197.0
100	338	OUTPUT (MBH)	1468.0	1412.0	1357.0	1303.0	1251.0	1199.0	1149.0	1099.0	1050.0	1002.0
		COND. (lbs/hr)	1654.0	1591.0	1529.0	1468.0	1409.0	1350.0	1293.0	1237.0	1182.0	1128.0
		FAT (°F)	142.5	149.9	157.1	164.2	171.2	178.0	184.7	191.4	197.9	204.3
150	366	OUTPUT (MBH)	1594.0	1536.0	1480.0	1425.0	1371.0	1318.0	1266.0	1215.0	1165.0	1116.0
		COND. (lbs/hr)	1844.0	1777.0	1712.0	1648.0	1586.0	1524.0	1464.0	1405.0	1347.0	1290.0
		FAT (°F)	156.3	163.7	171.1	178.3	185.3	192.3	199.1	205.8	212.5	218.9
200	387	OUTPUT (MBH)	1688.0	1629.0	1572.0	1516.0	1461.0	1407.0	1354.0	1302.0	1251.0	1201.0
		COND. (lbs/hr)	1997.0	1927.0	1859.0	1793.0	1727.0	1664.0	1601.0	1539.0	1479.0	1420.0
		FAT (°F)	166.7	174.2	181.6	188.9	196.1	203.1	210.0	216.8	223.5	230.0
250	406	OUTPUT (MBH)	1773.0	1714.0	1656.0	1598.0	1543.0	1488.0	1434.0	1381.0	1330.0	1279.0
		COND. (lbs/hr)	2144.0	2071.0	2001.0	1932.0	1864.0	1797.0	1732.0	1668.0	1606.0	1544.0
		FAT (°F)	176.2	183.8	191.3	198.6	205.8	212.9	219.9	226.8	233.5	240.1

Above figures are based on calculations at sea level and are intended as reference material only. Results may vary due to customer applications.

HP Heat Exchanger Capacities - 50% Ethylene Glycol, 60°F (16°C) EAT

		ENTERING GLYCOL TEMPERATURE															
		180°F (82°C)				200°F (93°C)				220°F (104°C)				240°F (116°C)			
MODEL	ΔT °F (°C)	OUTPUT FLOW		FAT °F (°C)	PD PSI	OUTPUT FLOW		FAT °F (°C)	PD PSI	OUTPUT FLOW		FAT °F (°C)	PD PSI	OUTPUT FLOW		FAT °F (°C)	PD PSI
		MBH	USGPM			MBH	USGPM			MBH	USGPM			MBH	USGPM		
HP1-12*	10 (5.6)	8.09	1.61	66.8 (19.3)	0.00	9.90	1.95	68.3 (20.2)	0.00	11.77	2.29	69.9 (21.1)	0.00	24.1	4.83	81.3 (27.4)	0.01
	20 (11.1)	5.96	.57	64.9 (18.3)	0.00	7.37	0.70	66.0 (18.9)	0.00	8.82	0.83	67.2 (19.6)	0.00	10.3	0.96	68.4 (20.2)	0.00
	40 (22.2)	4.11	.19	63.1 (17.3)	0.00	5.19	.023	64.0 (17.8)	0.00	6.30	0.28	64.8 (18.2)	0.00	7.45	0.33	65.7 (18.7)	0.00
HP3-12	10 (5.6)	23.0	4.88	80.8 (27.1)	0.36	31.3	6.57	88.4 (31.3)	0.64	38.2	7.94	94.8 (34.9)	0.92	45.2	9.28	101.1 (38.4)	1.25
	20 (11.1)	8.82	0.89	67.5 (19.7)	0.01	14.9	1.52	73.0 (22.8)	0.04	24.8	2.54	82.0 (27.8)	0.10	34.9	3.56	91.4 (33.0)	0.20
	40 (22.2)	6.13	0.30	65.0 (18.3)	0.00	7.73	0.37	66.3 (19.1)	0.00	9.40	0.45	67.7 (19.9)	0.00	11.1	0.53	69.2 (20.7)	0.01
HP1-16*	10 (5.6)	15.0	3.07	68.2 (20.1)	0.00	17.9	3.64	69.7 (20.9)	0.01	39.1	8.07	82.0 (27.8)	0.02	53.3	10.9	90.3 (32.4)	0.04
	20 (11.1)	11.1	1.11	65.9 (18.8)	0.00	13.7	1.35	67.3 (19.6)	0.00	16.3	1.60	68.7 (20.4)	0.00	19.1	1.85	70.2 (21.2)	0.00
	40 (22.2)	7.54	0.36	63.8 (17.7)	0.00	9.52	0.46	64.9 (18.3)	0.00	11.6	0.55	65.9 (18.8)	0.00	13.7	0.64	67.0 (19.4)	0.00
HP3-16	10 (5.6)	44.5	9.52	85.5 (29.7)	0.83	55.9	11.8	92.1 (33.4)	1.25	67.2	14.1	98.7 (37.1)	1.75	78.5	16.3	105.3 (40.7)	2.32
	20 (11.1)	20.9	2.19	71.6 (22.2)	0.05	36.9	3.88	80.9 (27.2)	0.15	52.7	5.50	90.0 (32.2)	0.29	64.3	6.64	96.8 (36.0)	0.41
	40 (22.2)	11.3	0.57	66.0 (18.9)	0.01	14.3	0.72	67.6 (19.8)	0.01	17.4	0.86	69.3 (20.7)	0.01	20.4	0.99	70.9 (21.6)	0.01
HP5-16	10 (5.6)	50.2	10.8	88.8 (31.6)	4.70	61.4	13.0	95.3 (35.2)	6.79	72.5	15.2	101.9 (38.8)	9.19	83.7	17.3	108.4 (42.4)	11.9
	20 (11.1)	36.9	3.95	81.0 (27.2)	0.68	50.4	5.34	88.8 (31.6)	1.21	61.9	6.48	95.5 (35.3)	1.75	73.3	7.59	102.1 (38.9)	2.38
	40 (22.2)	13.5	0.69	67.3 (19.6)	0.03	18.7	0.95	70.2 (21.2)	0.05	37.3	1.93	80.9 (27.2)	0.17	51.0	2.63	88.9 (31.6)	0.31
HP1-20*	10 (5.6)	31.0	6.52	69.9 (21.1)	0.01	61.3	12.9	80.0 (26.7)	0.04	84.4	17.7	87.6 (30.9)	0.08	109.2	22.6	95.9 (35.5)	0.13
	20 (11.1)	19.9	2.05	66.2 (19.0)	0.00	24.6	2.51	67.7 (19.8)	0.00	29.4	2.97	69.2 (20.7)	0.00	34.4	3.42	70.8 (21.6)	0.00
	40 (22.2)	12.6	0.63	63.8 (17.7)	0.00	17.0	0.85	65.2 (18.4)	0.00	20.7	1.02	66.3 (19.1)	0.00	24.5	1.20	67.5 (19.7)	0.00
HP3-20	10 (5.6)	81.3	17.5	86.8 (30.4)	1.91	100.5	21.4	93.2 (34.0)	2.81	119.6	25.2	99.6 (37.6)	3.83	138.7	28.9	106.0 (41.0)	4.99
	20 (11.1)	53.4	5.73	77.4 (25.2)	0.23	78.9	8.40	85.9 (29.9)	0.47	98.6	10.4	92.4 (33.6)	0.69	118.1	12.3	99.0 (37.2)	0.96
	40 (22.2)	20.3	1.06	66.4 (19.1)	0.01	25.6	1.32	68.0 (20.0)	0.02	42.9	2.22	73.7 (23.2)	0.04	71.5	3.70	83.2 (28.4)	0.10
HP5-20	10 (5.6)	89.1	19.2	89.4 (31.9)	10.3	—	—	—	—	—	—	—	—	—	—	—	—
	20 (11.1)	72.7	7.84	83.9 (28.8)	1.82	92.0	9.8	90.3 (32.4)	2.79	111.3	11.7	96.7 (35.9)	3.92	130.5	13.6	103.2 (39.6)	5.21
	40 (22.2)	23.7	1.25	67.5 (19.7)	0.06	55.5	2.95	78.0 (25.6)	0.29	82.3	4.35	87.0 (30.6)	0.59	102.2	5.34	93.6 (34.2)	0.86
HP1-24*	10 (5.6)	96.9	20.8	85.9 (29.9)	0.04	144.2	30.7	98.9 (37.2)	0.08	193.7	40.8	112.6 (44.8)	0.13	232.4	48.4	123.4 (50.8)	0.18
	20 (11.1)	45.4	4.78	71.8 (22.1)	0.00	56.1	5.83	74.6 (23.7)	0.00	67.1	6.89	77.5 (25.3)	0.01	133.3	13.8	95.6 (35.3)	0.02
	40 (22.2)	27.0	1.39	66.8 (19.3)	0.00	38.9	2.00	69.9 (21.1)	0.00	47.4	2.40	72.1 (22.3)	0.00	56.1	2.82	74.4 (23.6)	0.00
HP3-24	10 (5.6)	168.6	36.5	105.9 (41.1)	2.65	206.5	44.1	116.3 (46.8)	3.79	243.5	51.5	126.7 (52.6)	5.08	280.6	58.6	137.1 (58.4)	6.55
	20 (11.1)	122.9	13.3	93.1 (33.9)	0.39	169.2	18.1	105.9 (41.1)	0.69	207.6	22.2	116.5 (46.9)	0.99	245.7	25.7	127.2 (52.9)	1.33
	40 (22.2)	46.1	2.44	72.0 (22.2)	0.02	58.1	3.04	75.2 (24.0)	0.03	121.4	6.39	92.5 (33.6)	0.10	168.8	8.82	105.5 (40.8)	0.18
HP5-24	10 (5.6)	181.5	39.3	109.5 (43.1)	13.6	—	—	—	—	—	—	—	—	—	—	—	—
	20 (11.1)	152.9	16.6	101.5 (38.6)	2.60	190.8	20.4	112.0 (44.4)	3.85	228.5	24.2	122.4 (50.2)	5.30	265.9	27.8	132.9 (56.1)	6.93
	40 (22.2)	81.8	4.41	81.8 (27.7)	0.22	129.3	6.93	94.8 (34.9)	0.50	177.5	9.42	108.1 (42.3)	0.88	216.3	11.35	118.9 (48.3)	1.24
HP7-24	10 (5.6)	—	—	—	—	—	—	—	—	—	—	—	—	—	—	—	—
	20 (11.1)	163.5	17.7	104.4 (40.2)	7.89	201.1	21.5	114.8 (46.0)	11.4	—	—	—	—	—	—	—	—
	40 (22.2)	110.2	5.97	89.3 (31.8)	1.00	156.3	8.40	102.3 (39.1)	1.88	194.8	10.4	113.0 (45.0)	2.78	233.0	12.2	123.6 (50.9)	3.82
HP1-30*	10 (5.6)	178.0	38.4	95.9 (35.5)	0.09	247.9	53.0	110.3 (43.5)	0.16	302.7	64.0	121.7 (49.8)	0.23	357.2	74.6	133.1 (56.2)	0.30
	20 (11.1)	77.6	8.26	75.3 (24.1)	0.01	95.7	10.1	78.8 (26.0)	0.01	183.5	19.3	96.8 (36.0)	0.03	253.4	26.4	111.2 (44.0)	0.04
	40 (22.2)	42.5	2.22	68.1 (20.1)	0.00	61.2	3.18	71.8 (22.1)	0.00	81.9	4.23	75.9 (24.4)	0.00	96.9	4.95	78.9 (26.1)	0.00
HP3-30	10 (5.6)	252.7	54.8	110.4 (43.6)	4.19	305.7	65.5	122.5 (50.3)	5.85	358.5	75.9	133.5 (56.4)	7.73	411.1	86.0	144.6 (62.6)	9.83
	20 (11.1)	207.0	22.5	101.9 (38.8)	0.77	261.5	28.1	113.2 (45.1)	1.16	315.6	33.5	124.4 (51.3)	1.61	369.4	38.7	135.7 (57.6)	2.12
	40 (22.2)	78.0	4.17	75.3 (24.1)	0.04	151.5	8.10	90.3 (32.4)	0.12	219.3	11.6	104.2 (40.1)	0.22	290.7	15.3	119.0 (48.3)	0.37
HP5-30	10 (5.6)	—	—	—	—	—	—	—	—	—	—	—	—	—	—	—	—
	20 (11.1)	232.3	25.2	107.2 (41.8)	4.23	285.8	30.7	118.3 (47.9)	6.08	339.0	36.0	129.4 (54.1)	8.19	392.0	41.1	140.5 (50.3)	10.6
	40 (22.2)	151.9	8.25	90.5 (32.5)	0.52	220.9	11.9	104.7 (40.4)	1.01	276.1	14.7	116.1 (46.7)	1.49	330.7	17.4	127.5 (53.1)	2.04
HP7-30	10 (5.6)	—	—	—	—	—	—	—	—	—	—	—	—	—	—	—	—
	20 (11.1)	244.1	26.5	109.6 (43.1)	12.4	—	—	—	—	—	—	—	—	—	—	—	—
	40 (22.2)	186.3	10.2	97.6 (36.4)	2.00	241.0	13.0	108.9 (42.7)	3.16	295.5	15.7	120.2 (49.0)	4.52	349.5	18.4	131.5 (55.3)	6.05
HP1-36*	10 (5.6)	354.9	77.0	102.0 (38.9)	.024	446.6	95.8	113.1 (45.1)	0.36	537.7	114.0	124.2 (51.2)	0.49	628.2	131.7	135.3 (57.4)	0.64
	20 (11.1)	139.0	14.9	76.1 (24.5)	0.01	275.3	29.5	92.3 (33.5)	0.04	388.9	41.2	106.0 (41.1)	0.08	511.0	53.6	20.8 (49.3)	0.12
	40 (22.2)	69.6	3.7	67.9 (19.9)	0.00	101.5	5.3	71.6 (22.2)	0.00	147.0	7.7	76.9 (24.9)	0.00	174.0	9.0	80.0 (26.7)	0.00
HP3-36	10 (5.6)	437.5	95.1	112.1 (44.5)	8.6	526.1	113.0	122.8 (50.4)	11.8	—	—	—	—	—	—	—	—
	20 (11.1)	370.7	40.3	103.9 (39.9)	1.7	461.3	49.6	114.9 (46.1)	2.48	551.4	58.6	125.9 (52.3)	3.37	641.0	67.4	136.9 (52.3)	4.35
	40 (22.2)	201.6	11.0	83.6 (28.7)	0.16	315.9	17.0	97.2 (36.2)	0.34	431.9	23.0	111.2 (44.0)	0.58	524.6	27.7	122.5 (50.3)	0.81
HP5-36	10 (5.6)	—	—	—	—	—	—	—	—	—	—	—	—	—	—	—	—
	20 (11.1)	405.4	44.2	108.2 (42.3)	8.81	494.7	53.3	119.0 (48.3)	12.4	—	—	—	—	—	—	—	—
	40 (22.2)	292.7	16.0	94.5 (34.7)	1.31	397.1	21.5	107.1 (41.7)	2.24	488.7	26.1	118.2 (47.9)	3.21	579.6	30.6	129.3 (54.1)	4.3
HP7-36	10 (5.6)	—	—	—	—	—	—	—	—	—	—	—	—	—	—	—	—
	20 (11.1)	—	—	—	—	—	—	—	—	—	—	—	—	—	—	—	—
	40 (22.2)	333.4	18.2	99.4 (37.4)	4.4	424.8	23.0	110.4 (43.6)	6.7	515.4	27.6	121.4 (49.7)	9.4	605.3	32.0	132.4 (55.8)	12.4

* Single-pass heaters are not recommended for liquid service. In many cases, a smaller multi-pass model would be a more economical choice.

Notes:

HP Heat Exchanger Capacities - Water 60°F (16°C) EAT

CHANGE IN WATER TEMPERATURE		ENTERING WATER TEMPERATURE															
		180°F (82°C)				200°F (93°C)				220°F (104°C)				240°F (116°C)			
		MODEL	ΔT °F (°C)	OUTPUT MBH	FLOW USGPM	FAT °F (°C)	PD PSI	OUTPUT MBH	FLOW USGPM	FAT °F (°C)	PD PSI	OUTPUT MBH	FLOW USGPM	FAT °F (°C)	PD PSI	OUTPUT MBH	FLOW USGPM
HP1-12*	10 (5.6)	19.3	3.66	77.2 (25.1)	0.01	27.1	5.15	84.4 (29.1)	0.01	35.6	6.77	92.2 (33.4)	0.02	42.5	8.07	98.6 (37.0)	0.03
	20 (11.1)	8.84	0.80	67.5 (19.7)	0.00	11.1	1.00	69.4 (20.8)	0.00	15.3	1.40	73.2 (22.9)	0.00	26.2	2.44	83.2 (28.4)	0.00
	40 (22.2)	6.11	0.27	65.0 (18.3)	0.00	7.86	0.34	66.5 (19.2)	0.00	9.72	0.43	68.0 (20.0)	0.00	11.7	0.51	69.7 (20.9)	0.00
HP3-12	10 (5.6)	30.6	5.90	87.9 (31.1)	0.46	37.4	7.18	94.1 (34.5)	0.68	44.1	8.44	100.3 (37.9)	0.93	50.8	9.70	106.5 (41.4)	1.23
	20 (11.1)	23.1	2.21	80.8 (27.1)	0.07	30.1	2.96	88.1 (31.2)	0.12	37.8	3.61	94.4 (34.7)	0.18	44.7	4.25	100.7 (38.2)	0.24
	40 (22.2)	8.84	0.40	67.5 (19.7)	0.00	14.4	0.66	72.5 (22.5)	0.01	23.7	1.11	81.0 (27.2)	0.02	31.6	1.49	88.3 (31.3)	0.03
HP1-16*	10 (5.6)	38.8	7.47	82.1 (27.8)	0.02	52.3	10.1	90.0 (32.2)	0.03	63.6	12.2	96.5 (35.8)	0.05	74.9	14.4	103.1 (39.5)	0.06
	20 (11.1)	16.3	1.15	68.9 (20.5)	0.00	25.8	2.42	91.4 (33.1)	0.03	41.4	3.93	83.4 (28.6)	0.01	54.7	5.20	91.1 (32.8)	0.01
	40 (22.2)	11.5	0.51	66.0 (18.9)	0.00	14.5	0.66	67.7 (19.8)	0.00	17.9	0.81	69.6 (20.9)	0.00	21.5	0.97	71.6 (22.0)	0.00
HP3-16	10 (5.6)	52.9	10.2	90.4 (32.4)	0.84	63.9	12.4	96.8 (36.0)	1.21	74.9	14.4	103.3 (39.6)	1.65	86.0	16.5	109.7 (43.2)	2.15
	20 (11.1)	43.7	4.22	85.0 (29.4)	0.15	54.9	5.29	91.5 (33.1)	0.23	66.1	6.36	98.0 (36.7)	0.33	77.3	7.41	104.5 (40.3)	0.45
	40 (22.2)	19.3	0.91	70.7 (21.5)	0.01	34.5	1.64	79.5 (26.4)	0.02	47.4	2.26	86.9 (30.5)	0.04	61.3	2.93	95.0 (35.0)	0.07
HP5-16	10 (5.6)	55.8	10.8	92.1 (33.4)	4.23	66.7	12.9	98.5 (36.9)	5.98	77.7	15.0	104.9 (40.5)	8.04	88.6	17.0	111.3 (44.1)	10.4
	20 (11.1)	48.7	4.71	87.9 (31.1)	0.84	59.8	5.77	94.4 (34.7)	1.24	70.9	6.82	100.8 (38.2)	1.72	81.9	7.87	107.3 (41.8)	2.28
	40 (22.2)	33.5	1.61	79.0 (26.1)	0.10	46.7	2.25	86.0 (30.3)	0.20	58.0	2.78	93.2 (34.0)	0.30	69.3	3.32	99.8 (37.7)	0.42
HP1-20*	10 (5.6)	76.4	14.8	85.1 (29.5)	0.05	95.4	18.5	91.5 (33.1)	0.07	114.5	22.1	97.8 (36.6)	0.11	133.6	25.8	104.2 (40.1)	0.14
	20 (11.1)	39.3	3.77	72.7 (22.6)	0.00	64.0	6.16	80.9 (27.2)	0.01	85.7	8.25	88.1 (31.2)	0.02	109.7	10.6	96.1 (32.8)	0.03
	40 (22.2)	20.2	0.94	66.1 (19.1)	0.00	25.9	1.21	68.1 (20.1)	0.00	32.1	1.49	70.1 (21.2)	0.00	37.8	1.77	71.9 (22.2)	0.00
HP3-20	10 (5.6)	92.8	18.1	90.7 (32.6)	1.79	111.5	21.7	96.9 (36.1)	2.54	130.2	25.2	103.2 (39.6)	3.43	148.9	28.8	109.5 (43.1)	4.44
	20 (11.1)	79.2	7.71	86.1 (30.1)	0.34	98.2	9.53	92.4 (33.6)	0.52	117.1	11.3	98.7 (37.1)	0.72	136.0	13.1	105.1 (40.6)	0.96
	40 (22.2)	48.6	2.35	75.8 (24.3)	0.04	70.0	3.38	82.9 (28.3)	0.07	92.7	4.48	90.5 (32.5)	0.12	112.0	5.40	96.9 (36.1)	0.17
HP5-20	10 (5.6)	96.8	18.9	92.0 (33.3)	8.78	115.4	22.4	98.3 (36.8)	12.3	—	—	—	—	—	—	—	—
	20 (11.1)	86.1	8.39	88.4 (31.3)	1.81	104.9	10.2	94.7 (34.8)	2.64	123.7	12.0	101.0 (38.3)	3.62	142.4	13.8	107.3 (41.8)	4.75
	40 (22.2)	65.8	3.19	81.6 (27.6)	0.28	84.9	4.12	87.9 (31.1)	0.46	104.0	5.03	94.3 (34.6)	0.67	123.2	5.94	100.7 (38.2)	0.93
HP1-24*	10 (5.6)	160.4	31.3	103.6 (39.8)	0.07	197.8	38.5	113.9 (45.5)	0.10	235.1	45.6	124.3 (57.3)	1.14	272.3	52.7	134.8 (57.1)	0.19
	20 (11.1)	102.4	9.93	87.5 (30.8)	0.01	146.2	14.2	99.5 (37.5)	0.02	193.6	18.8	112.6 (44.8)	0.03	231.7	22.4	123.2 (50.7)	0.04
	40 (22.2)	45.7	2.17	71.9 (22.2)	0.00	58.6	2.78	75.3 (24.1)	0.00	72.3	3.42	78.9 (26.1)	0.00	130.0	6.22	94.7 (34.8)	0.00
HP3-24	10 (5.6)	187.5	36.6	111.1 (43.9)	2.33	224.1	43.7	121.3 (49.6)	3.28	260.6	50.6	131.6 (55.3)	4.38	297.1	57.5	141.9 (61.1)	5.64
	20 (11.1)	16.7	16.0	104.5 (40.3)	0.47	200.8	19.6	114.8 (46.0)	0.69	237.9	23.1	125.1 (51.7)	0.95	274.8	26.6	135.5 (57.5)	1.26
	40 (22.2)	111.2	5.41	89.9 (32.2)	0.06	156.7	7.61	102.4 (39.1)	0.11	194.6	9.44	112.9 (44.9)	0.17	232.5	11.3	123.4 (50.8)	0.24
HP5-24	10 (5.6)	194.0	37.9	113.0 (45.0)	11.2	—	—	—	—	—	—	—	—	—	—	—	—
	20 (11.1)	175.1	17.1	107.7 (42.1)	2.40	211.9	20.6	117.9 (47.7)	3.44	248.6	24.2	128.2 (53.4)	4.67	285.2	27.6	138.5 (59.2)	6.08
	40 (22.2)	138.2	6.74	97.4 (36.3)	0.40	175.8	8.56	107.8 (42.1)	0.63	213.4	10.4	118.2 (47.9)	0.91	250.7	12.1	128.7 (53.7)	1.23
HP7-24	10 (5.6)	—	—	—	—	—	—	—	—	—	—	—	—	—	—	—	—
	20 (11.1)	180.4	17.6	109.2 (42.9)	6.82	217.1	21.2	119.4 (48.6)	9.72	253.6	24.6	129.6 (54.2)	13.1	—	—	—	—
	40 (22.2)	147.5	7.20	100.0 (37.8)	1.22	184.9	9.01	110.3 (43.5)	1.86	222.2	10.8	120.7 (49.3)	2.63	259.3	12.6	131.0 (55.0)	3.53
HP1-30*	10 (5.6)	243.3	47.6	109.5 (43.1)	0.11	296.2	57.8	120.5 (49.2)	0.16	349.0	67.9	131.5 (55.3)	0.22	401.7	77.9	142.6 (61.4)	0.29
	20 (11.1)	179.3	17.6	96.2 (35.7)	0.02	245.6	23.9	109.8 (43.2)	0.03	299.6	29.1	121.0 (49.4)	0.04	353.4	34.2	132.3 (55.7)	0.06
	40 (22.2)	77.0	3.69	75.2 (24.0)	0.00	98.5	4.72	79.4 (26.3)	0.00	174.8	8.43	95.0 (35.0)	0.00	242.3	11.7	108.9 (42.7)	0.01
HP3-30	10 (5.6)	273.8	53.6	115.8 (46.1)	3.48	325.8	63.6	126.7 (52.6)	4.85	377.6	73.5	137.6 (58.7)	6.42	429.4	83.3	148.5 (64.7)	8.20
	20 (11.1)	244.3	23.9	109.7 (43.2)	0.74	296.9	29.0	120.6 (49.2)	1.06	349.5	34.0	131.6 (55.3)	1.44	401.8	39.0	142.6 (61.4)	1.88
	40 (22.2)	180.9	8.83	96.5 (35.8)	0.11	241.3	11.80	108.9 (42.7)	0.19	295.1	14.1	120.1 (48.9)	0.28	348.7	16.9	131.3 (55.2)	0.38
HP5-30	10 (5.6)	—	—	—	—	—	—	—	—	—	—	—	—	—	—	—	—
	20 (11.1)	257.1	25.2	112.3 (44.6)	3.62	309.3	30.2	123.2 (50.7)	5.14	361.5	35.2	134.1 (56.7)	6.90	413.4	40.1	145.1 (62.8)	8.91
	40 (22.2)	209.5	10.2	102.4 (39.1)	0.65	263.0	12.8	113.5 (45.3)	1.00	316.2	15.4	124.6 (57.4)	1.40	369.2	17.9	135.7 (57.6)	1.87
HP7-30	10 (5.6)	—	—	—	—	—	—	—	—	—	—	—	—	—	—	—	—
	20 (11.1)	263.1	25.8	113.6 (45.3)	10.2	—	—	—	—	—	—	—	—	—	—	—	—
	40 (22.2)	220.1	10.8	104.6 (40.3)	1.91	273.3	13.3	115.6 (46.4)	2.86	326.2	15.9	126.6 (52.6)	3.98	378.8	18.4	137.7 (58.7)	5.28
HP1-36*	10 (5.6)	424.5	83.2	110.5 (43.6)	0.24	513.3	100.3	121.2 (49.6)	0.33	601.2	117.2	132.0 (55.6)	0.45	689.2	134.0	142.9 (61.6)	0.57
	20 (11.1)	349.1	34.2	101.3 (38.5)	0.04	439.1	42.9	112.2 (44.6)	0.07	529.1	51.6	123.1 (50.6)	0.09	618.8	60.1	134.1 (56.7)	0.13
	40 (22.2)	137.2	6.60	75.9 (24.4)	0.00	257.0	12.53	90.1 (32.3)	0.01	366.6	17.8	103.3 (39.6)	0.01	467.9	22.7	115.5 (46.4)	0.02
HP3-36	10 (5.6)	466.5	91.5	115.6 (46.4)	6.89	553.6	108.3	126.2 (52.3)	9.51	640.5	124.9	136.9 (58.3)	12.5	—	—	—	—
	20 (11.1)	421.9	41.4	110.2 (43.4)	1.51	510.0	49.9	120.9 (49.4)	2.14	597.8	58.3	131.6 (55.3)	2.88	685.5	66.7	142.4 (61.3)	3.73
	40 (22.2)	334.7	16.4	99.6 (37.6)	0.26	424.9	20.8	110.4 (43.6)	0.41	514.7	25.1	121.3 (49.6)	0.58	604.1	29.4	132.3 (55.7)	0.78
HP5-36	10 (5.6)	—	—	—	—	—	—	—	—	—	—	—	—	—	—	—	—
	20 (11.1)	439.5	43.1	112.3 (44.6)	7.22	527.0	51.6	123.0 (50.6)	10.2	—	—	—	—	—	—	—	—
	40 (22.2)	365.4	17.9	103.3 (39.6)	1.36	454.9	22.3	114.1 (45.6)	20.3	543.8	26.5	124.9 (51.6)	2.83	632.3	30.8	135.8 (57.7)	3.75
HP7-36	10 (5.6)	—	—	—	—	—	—	—	—	—	—	—	—	—	—	—	—
	20 (11.1)	—	—	—	—	—	—	—	—	—	—	—	—	—	—	—	—
	40 (22.2)	380.0	18.6	105.1 (40.6)	3.88	469.0	23.0	115.8 (46.6)	5.73	557.5	27.2	126.6 (52.6)	7.93	645.6	31.4	137.4 (58.6)	10.5

* Single-pass heaters are not recommended for liquid service. In many cases, a smaller multi-pass model would be a more economical choice.

Notes:

For 50 Hz power supply, derate output by 10%. Above figures are based on calculations at sea level.

Thermal Performance Analysis or Heat Loss Calculation Service:

Thermal Performance Analysis service accurately computes performance parameters and output capacities for all Ruffneck™ models. Accompanied with the computerized Heat Loss Calculation for your project, our staff can inform you of the best choice of Ruffneck™ models for your needs.

Specifications: HP1-12, HP3-12

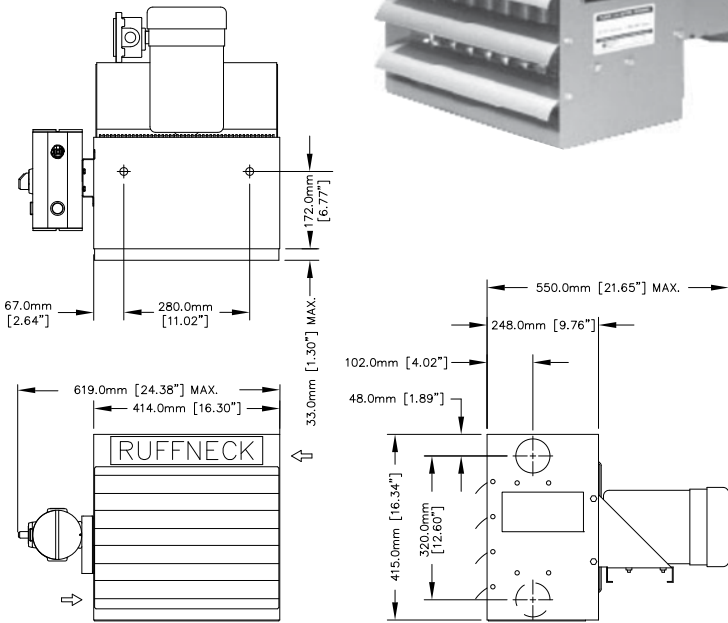

General

Air Delivery*	997 CFM
Air Velocity*	1147 FPM
Air Throw*	40 ft @ 15 psi stream
Propeller Fan	3 Wing Aluminum, 12" (305 mm) Dia. x 5/8" (16 mm) Bore
Motor Requirements	1/2 HP, 1725 RPM, Frame 56 Rigid Base (Specify enclosure type, voltage, cycle and phase.)
Fan Guard	Welded, Wire, Powder Coated Epoxy 1/4" (6 mm) probe will not enter.
Hanger Connections	5/8" (16 mm) NC Tap - 2 holes
Cabinet Material	0.075" (2 mm) steel
Louvre Blades	Anodized Extruded Aluminum
Net Weight	75 lbs (34 kg) ◇ *
Shipping Weight	102 lbs (46.3 kg) ◇ *

Heat Exchanger

Tube Outside Dia.	0.625" (16 mm)
Tube Wall Thickness	0.065" (1.65 mm) Average
Tube Material	SA 214 Carbon Steel
Fin Material	1050 Aluminum
Fins Per Inch	10
Number of Tubes	13
Number of Rows	2
Number of Passes	1 or 3
Header Material	Min. 0.135" (3.4 mm) Steel
Inlet/Outlet	2" NPT Female
Max. Operating Press.	400 psi
Max. Operating Temp.	572°F (300°C)

◇ Add 12 lbs (5.4 kg) to flange units * Add 15 lbs (6.8 kg) to disconnect units

Specifications: HP1-16, HP3-16, HP5-16

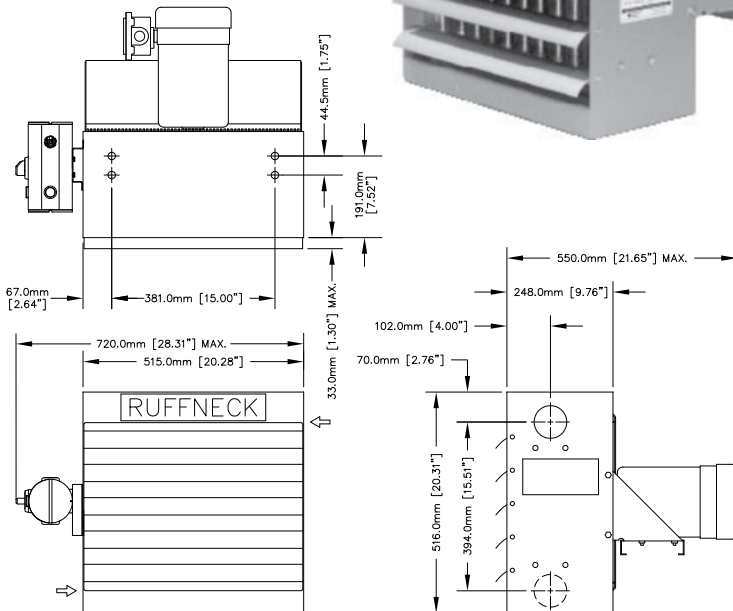

General

Air Delivery*	1588 CFM
Air Velocity*	1069 FPM
Air Throw*	60 ft @ 15 psi stream
Propeller Fan	3 Wing Aluminum, 16" (406 mm) Dia. x 5/8" (16 mm) Bore
Motor Requirements	1/2 HP, 1725 RPM, Frame 56 Rigid Base (Specify enclosure type, voltage, cycle and phase.)
Fan Guard	Welded, Wire, Powder Coated Epoxy 1/4" (6 mm) probe will not enter.
Hanger Connections	5/8" (16 mm) NC Tap - 4 holes
Cabinet Material	0.075" (2 mm) steel
Louvre Blades	Anodized Extruded Aluminum
Net Weight	109 lbs (49.4 kg) ◇ *
Shipping Weight	137 lbs (62.1 kg) ◇ *

Heat Exchanger

Tube Outside Dia.	0.625" (16 mm)
Tube Wall Thickness	0.065" (1.65 mm) Average
Tube Material	SA 214 Carbon Steel
Fin Material	1050 Aluminum
Fins Per Inch	10
Number of Tubes	17
Number of Rows	2
Number of Passes	1, 3 or 5
Header Material	Min. 0.135" (3.4 mm) Steel
Inlet/Outlet	2" NPT Female
Max. Operating Press.	400 psi
Max. Operating Temp.	572°F (300°C)

◇ Add 12 lbs (5.4 kg) to flange units * Add 15 lbs (6.8 kg) to disconnect units

* at 70°F (21°C) at sea level

**Specifications:
HP1-20, HP3-20,
HP5-20**

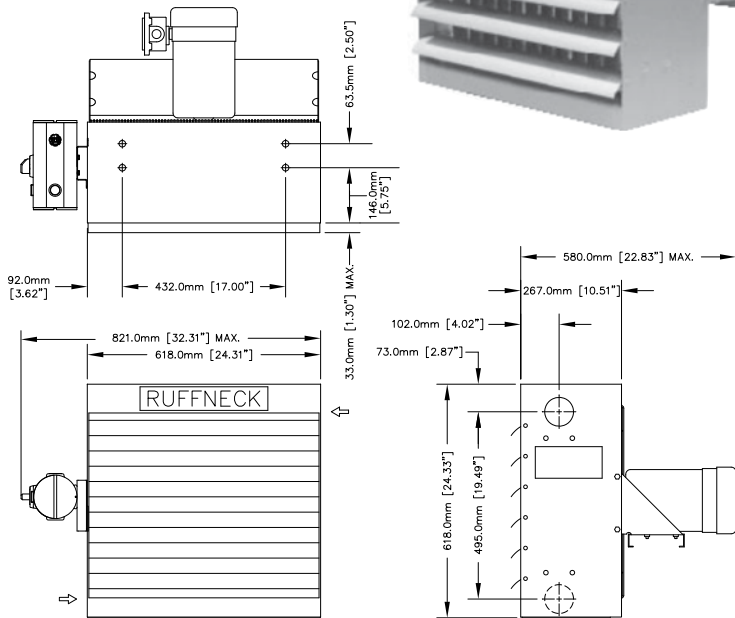

General

Air Delivery*	2780 CFM
Air Velocity*	1153 FPM
Air Throw*	65 ft @ 15 psi stream
Propeller Fan	3 Wing Aluminum, 20" (508 mm) Dia. x 5/8" (16 mm) Bore
Motor Requirements	1/2 HP, 1725 RPM, Frame 56 Rigid Base (Specify enclosure type, voltage, cycle and phase.)
Fan Guard	Welded, Wire, Powder Coated Epoxy 1/4" (6 mm) probe will not enter.
Hanger Connections	5/8" (16 mm) NC Tap - 4 holes
Cabinet Material	0.075" (2 mm) steel
Louvre Blades	Anodized Extruded Aluminum
Net Weight	138 lbs (62.6 kg) ◇ *
Shipping Weight	161 lbs (73 kg) ◇ *

Heat Exchanger

Tube Outside Dia.	0.625" (16 mm)
Tube Wall Thickness	0.065" (1.65 mm) Average
Tube Material	SA 214 Carbon Steel
Fin Material	1050 Aluminum
Fins Per Inch	10
Number of Tubes	21
Number of Rows	2
Number of Passes	1, 3 or 5
Header Material	Min. 0.135" (3.4 mm) Steel
Inlet/Outlet	2" NPT Female
Max. Operating Press.	400 psi
Max. Operating Temp.	572°F (300°C)

◇ Add 12 lbs (5.4 kg) to flange units * Add 15 lbs (6.8 kg) to disconnect units

**Specifications:
HP1-24, HP3-24,
HP5-24, HP7-24**

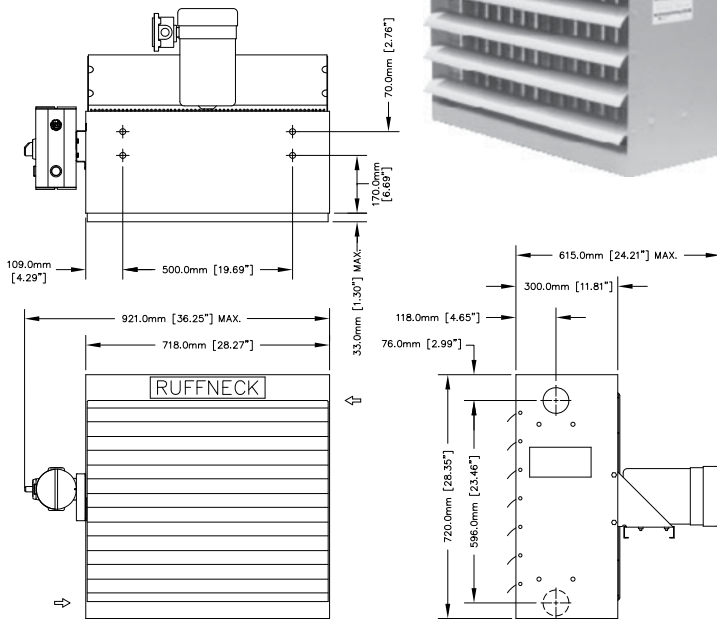

General

Air Delivery*	3405 CFM
Air Velocity*	981 FPM
Air Throw*	70 ft @ 15 psi stream
Propeller Fan	3 Wing Aluminum, 24" (610 mm) Dia. x 5/8" (16 mm) Bore
Motor Requirements	1/2 HP, 1725 RPM, Frame 56 Rigid Base (Specify enclosure type, voltage, cycle and phase.)
Fan Guard	Welded, Wire, Powder Coated Epoxy 7/16" (11 mm) probe will not enter.
Hanger Connections	5/8" (16 mm) NC Tap - 4 holes
Cabinet Material	0.075" (2 mm) steel
Louvre Blades	Anodized Extruded Aluminum
Net Weight	191 lbs (86.6 kg) ◇ *
Shipping Weight	224 lbs (101.6 kg) ◇ *

Heat Exchanger

Tube Outside Dia.	0.625" (16 mm)
Tube Wall Thickness	0.065" (1.65 mm) Average
Tube Material	SA 214 Carbon Steel
Fin Material	1050 Aluminum
Fins Per Inch	10
Number of Tubes	38
Number of Rows	3
Number of Passes	1, 3, 5 or 7
Header Material	Min. 0.135" (3.43 mm) Steel
Inlet/Outlet	2" NPT Female
Max. Operating Press.	Up to 300 psi 100 psi for CSA Certified Steam Heaters
Max. Operating Temp.	572°F (300°C)

* at 70°F (21°C) at sea level

◇ Add 12 lbs (5.4 kg) to flange units * Add 15 lbs (6.8 kg) to disconnect units

HP

**Specifications:
HP1-30, HP3-30,
HP5-30, HP7-30**

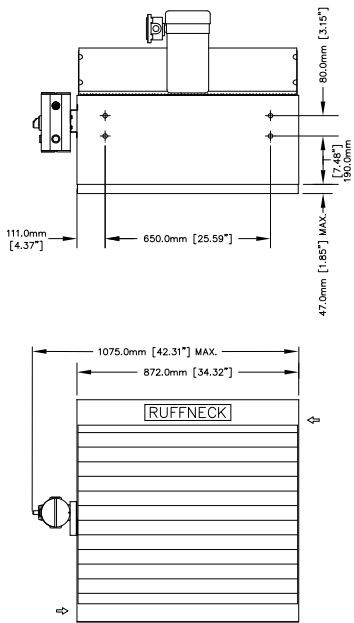

General

Air Delivery*	4569 CFM
Air Velocity*	814 FPM
Air Throw*	70 ft @ 15 psi stream
Propeller Fan	3 Wing Aluminum, 30" (762 mm) Dia. x 5/8" (16 mm) Bore
Motor Requirements	3/4 HP, 1140 RPM, Frame 56 Rigid Base (Specify enclosure type, voltage, cycle and phase.)
Fan Guard	Welded, Wire, Powder Coated Epoxy 7/16" (11 mm) probe will not enter.
Hanger Connections	5/8" (16 mm) NC Tap - 4 holes
Cabinet Material	0.075" (2 mm) steel
Louvre Blades	Anodized Extruded Aluminum
Net Weight	286 lbs (121.6 kg) ◇ *
Shipping Weight	345 lbs (156.5 kg) ◇ *

Heat Exchanger

Tube Outside Dia.	0.625" (16 mm)
Tube Wall Thickness	0.065" (1.65 mm) Average
Tube Material	SA 214 Carbon Steel
Fin Material	1050 Aluminum
Fins Per Inch	10
Number of Tubes	47
Number of Rows	3
Number of Passes	1, 3, 5 or 7
Header Material	Min. 0.135" (3.43 mm) Steel
Inlet/Outlet	2" NPT Female
Max. Operating Press.	Up to 300 psi 80 psi for CSA Certified Steam Heaters
Max. Operating Temp.	572°F (300°C)

◇ Add 12 lbs (5.4 kg) to flange units * Add 15 lbs (6.8 kg) to disconnect units

**Specifications:
HP1-36, HP3-36,
HP5-36, HP7-36**

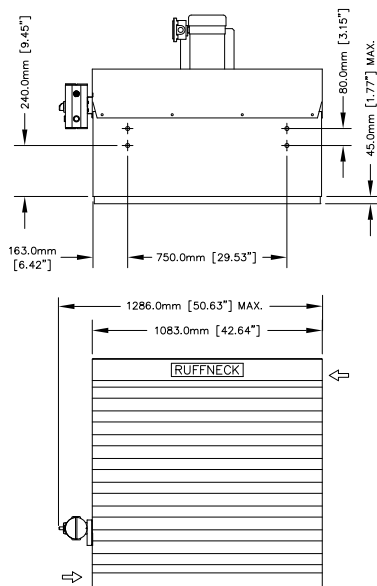

General

Air Delivery*	7830 CFM
Air Velocity*	852 FPM
Air Throw*	65 ft @ 15 psi stream
Propeller Fan	6 Wing Aluminum, 36" (914 mm) Dia. x 1" (25mm) Bore
Motor Requirements	1½ HP, 1725 RPM, Frame 56 Rigid Base (Specify enclosure type, voltage, cycle and phase.)
Drive Pulley	B3.6"
Driven Pulley	B9.9"
Drive Belt	B42 V-Belt
Fan Speed	627 RPM
Fan Guard	Steel, Powder Coated Epoxy, 1/2" (13 mm) gap
Hanger Connections	5/8" (16 mm) NC Tap - 4 holes
Cabinet Material	0.105" (2.66 mm) steel
Louvre Blades	Anodized Extruded Aluminum
Net Weight	534 lbs (242.2 kg) ◇ *
Shipping Weight	597 lbs (270.8 kg) ◇ *

Heat Exchanger

Tube Outside Dia.	0.625" (16 mm)
Tube Wall Thickness	0.065" (1.65 mm) Average
Tube Material	SA 214 Carbon Steel
Fin Material	1050 Aluminum
Fins Per Inch	10
Number of Tubes	59
Number of Rows	3
Number of Passes	1, 3, 5 or 7
Header Material	Min. 0.135" (3.43 mm) Steel
Inlet/Outlet	2" NPT Female
Max. Operating Press.	Up to 300 psi 85 psi for CSA Certified Steam Heaters
Max. Operating Temp.	572°F (300°C)

◇ Add 12 lbs (5.4 kg) to flange units * Add 15 lbs (6.8 kg) to disconnect units

* at 70°F (21°C) at sea level

Advanced Series Heaters

The Ruffneck™ Advanced Series heaters are designed for rugged industrial applications and are available in 37 models from 6,000 to 1,200,000 Btu/hr. With a maximum operating pressure and temperature rating of 450 psi and

650°F (343°C) respectively, the Advanced Series is perfect for steam, circulating hot water, and glycol heating systems or liquid cooling applications that include: flash stream condensers, lube oil coolers, and pump seal coolers, etc.

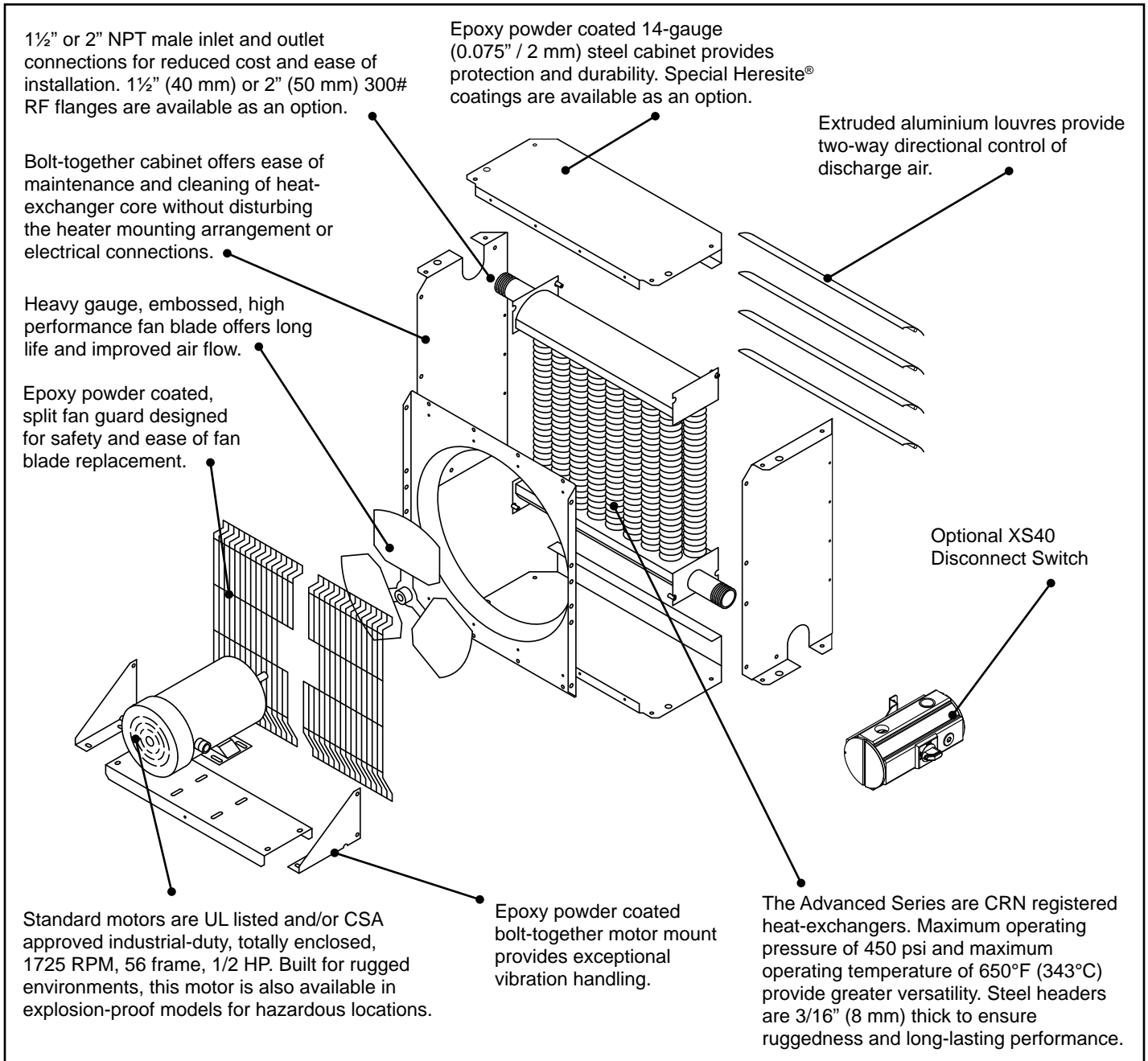

AH / AV

AH - Advanced Horizontal Model



The Advanced Horizontal unit heater exchanger can be customised for your application. The heat exchanger is comprised of extruded finned tubing in 10, 9 and 5 fins per inch for varying steam conditions and/or where atmospheric particulate may cause premature fouling of the heater core. Additionally, the AH can handle more pressure than the HP and FR.

Available with Disconnect Switch (not shown).

AV - Advanced Vertical Model



Ruffneck's Advanced Series unit heaters are designed for rugged industrial applications meeting the most demanding service and long life requirements.

While perfect for steam, circulating hot water or glycol heating systems, the Ruffneck™ Vertical Throw heaters are also suitable for a wide range of other heating fluids. In addition, they can be used for both space heating and liquid cooling applications.

AH - Advanced Horizontal Tandem Model



The 24" (610 mm) Tandem Advanced Horizontal Series is the largest unit in our line-up. Rather than expanding the cabinet and heat exchanger in both height and width, we just doubled the width to produce this unique model. This side-by-side arrangement also produces the lowest mounting profile in its class for a heater of equivalent output.

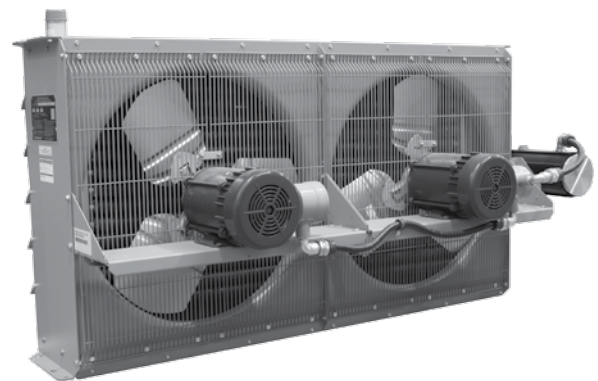

The dual fan arrangement allows for two smaller fans that can be operated at the standard 1725 RPM. Furthermore, dual fans provide for output modulation if separate motor thermostats are used. Separate motor thermostats produce better control of heating during periods of low demand by reducing the output of the heater.

Unit available with Disconnect Switch (shown).

AH / AV

Extruded Finned Tubing Types

**5/8" (16 mm) Tension-Wound
Finned Tubing
10 Fins per Inch**



Recommended for glycol or water applications, we offer our standard 5/8" (16 mm) outside diameter (16-gauge, 0.065" / 1.65 mm wall thickness) carbon steel tubes with tension wound aluminum fins (10 per inch). In most cases, the 5/8" (16 mm) tubing will be the most economical choice on a cost per Btu basis.

**1" (25 mm) Extruded
Finned Tubing
9 Fins per Inch**



Select this configuration of extruded finned tubing for more demanding applications. It utilizes 1" (25 mm) outside diameter (14-gauge, 0.083" / 2 mm wall thickness) carbon steel tubes with extruded aluminum fins (9 per inch).

**1" (25 mm) Extruded
Finned Tubing
5 Fins per Inch**



For the harshest steam applications and/or where atmospheric particulate may cause premature fouling of the heater core, use the 1" (25 mm) outside diameter (10 gauge, 0.135" / 3.4 mm wall thickness) carbon steel tubes with extruded aluminum fins (5 per inch).

Advanced Series- General Specifications

Approvals	CRN (Canada) - Steam and HVAC liquids only. CSA certified Class I, Divisions 1 & 2, Groups C & D; Class II, Division 1 & 2, Groups E, F, & G; Class III, Division 1 & 2, Temperature Code T3B 329°F (165°C)
Fan	Three blade aluminum, steel spider and hub with 5/8" (16 mm) bore
Fan Guard	Two piece design with close wire spacing. 3/8" (9.5 mm) diameter probe will not enter. Epoxy coated to match cabinet colour
Mounting Holes	9/16" (14 mm) diameter holes, two at top and two at bottom of heater
Cabinet Material & Nozzle	14-gauge (0.075" / 2 mm) epoxy coated steel
Motors	CSA and/or UL listed 1725 RPM permanently lubricated ball bearing type with rigid base. Explosion-proof or general purpose construction. All 50 and 60 hertz standard voltages are available
Louvre Blades	Anodized extruded aluminum
Header Material	3/16" (5 mm) carbon steel
Fluid Connections	1 1/2" or 2" NPT Male or 1 1/2" (40 mm) or 2" (50 mm) 300# RF Flanges
Max. Operating Press.	450 psi. Contact manufacturer for steam operating restrictions.
Max. Operating Temp.	650°F (343°C)
Finned Tubes	5/8" (16 mm) outside diameter (16-gauge, 0.065" / 1.7 mm wall thickness) carbon steel tubes Tension wound aluminum fins @ 10 fins per inch, or 1" (25 mm) outside diameter (14-gauge, 0.083" / 2 mm wall thickness) carbon steel tubes Extruded aluminum fins @ 9 fins per inch or 1" (25 mm) outside diameter (10-gauge, 0.135" / 3.4 mm wall thickness) carbon steel tubes Extruded aluminum fins @ 5 fins per inch
Optional Disconnect	XS40 Disconnect Switch suitable for 1 or 3 phase motors

AH / AV

AH Series - Model Specifications

BASE MODEL	AIR DELIVERY*	AIR THROW AT 15 PSI STREAM	MOTOR† REQUIREMENTS	TUBE PASSES	MAX ALLOWABLE PRESSURE for Steam Units▲	NET WEIGHT‡▲ lbs (kg)	SHIPPING WEIGHT‡▲ lbs (kg)	AIR VELOCITY (FT/MIN)	MAX. MOUNTING HEIGHT
AH-12A-A_	1150 CFM	28' (8.5 m)	1/2 HP	1 or 3	150 psi	102 (46.3)	146 (66.2)	1441	12' (3.66 m)
AH-12A-B_	1160 CFM	28' (8.5m)	1/2 HP	1 or 3	200 psi	107 (48.5)	151 (68.5)	1454	12' (3.66 m)
AH-12A-C1	1030 CFM	28' (8.5m)	1/2 HP	1	300 psi	118 (53.5)	164 (74.4)	1291	12' (3.66 m)
AH-16A-A_	1840 CFM	40' (12.2m)	1/2 HP	1, 3 or 5	135 psi	127 (57.6)	174 (80.0)	1301	16' (4.88 m)
AH-16A-B_	1780 CFM	40' (12.2m)	1/2 HP	1, 3 or 5	150 psi	138 (62.6)	177 (80.3)	1259	16' (4.88 m)
AH-16A-C1	1840 CFM	40' (12.2m)	1/2 HP	1	395 psi	153 (69.4)	199 (90.3)	1301	16' (4.88 m)
AH-20A-A_	2930 CFM	40' (12.2m)	1/2 HP	1, 3 or 5	180 psi	155 (70.3)	209 (94.8)	1499	18' (5.49 m)
AH-20A-B_	2700 CFM	40' (12.2m)	1/2 HP	1, 3 or 5	140 psi	170 (77.1)	209 (94.8)	1382	18' (5.49 m)
AH-20A-C1	3000 CFM	40' (12.2m)	1/2 HP	1	450 psi	195 (88.5)	242 (109.8)	1535	18' (5.49 m)
AH-24A-A_	3890 CFM	40' (12.2m)	1/2 HP	1, 3, 5 or 7	165 psi	189 (85.7)	247 (112.0)	1288	20' (6.10 m)
AH-24A-B_	3640 CFM	40' (12.2m)	1/2 HP	1, 3, 5 or 7	190 psi	212 (96.1)	251 (113.9)	1205	20' (6.10 m)
AH-24A-C1	3490 CFM	40' (12.2m)	1/2 HP	1	335 psi	258 (117.0)	293 (132.9)	1115	20' (6.10 m)
AH-24B-A_	7650 CFM	65' (19.8m)	2 x 1/2 HP	1, 3, 5 or 7	235 psi	313 (142.0)	361 (163.7)		20' (6.10 m)
AH-24B-B_	7420 CFM	65' (19.8m)	2 x 1/2 HP	1, 3, 5 or 7	295 psi	376 (170.6)	424 (192.3)		20' (6.10 m)
AH-24B-C1	6690 CFM	65' (19.8m)	2 x 1/2 HP	1	450 psi	440 (200.0)	488 (221.4)		20' (6.10 m)

Next page for model coding.

* at 70°F (21°C) at sea level.

† CCI Thermal Technology Inc. reserves the right to substitute motors of higher horsepower.

‡ Add 12 lbs to flanged units.

▲ Add 15 lbs (6.8 kg) to Disconnect units

▲ Pressure restrictions for CSA Certified heaters only

AV Series - Model Specifications

BASE MODEL	AIR DELIVERY*	AIR THROW AT 15 PSI STREAM	MOTOR† REQUIREMENTS	TUBE PASSES	NET WEIGHT‡ lbs (kg)	SHIPPING WEIGHT‡ lbs (kg)	AIR VELOCITY (FT/MIN)	MAX. MOUNTING HEIGHT
AV-12A-A_	1150 CFM	28' (8.5 m)	1/2 HP	1 or 3	102 (46.3)	146 (66.2)	1441	12' (3.66 m)
AV-12A-B_	1160 CFM	28' (8.5m)	1/2 HP	1 or 3	107 (48.5)	151 (68.5)	1454	12' (3.66 m)
AV-12A-C1	1030 CFM	28' (8.5m)	1/2 HP	1	118 (52.5)	164 (74.4)	1291	12' (3.66 m)'
AV-16A-A_	1840 CFM	40' (12.2m)	1/2 HP	1, 3 or 5	127 (57.6)	174 (78.9)	1301	16' (4.88 m)
AV-16A-B_	1780 CFM	40' (12.2m)	1/2 HP	1, 3 or 5	138 (62.6)	177 (80.3)	1259	16' (4.88 m)
AV-16A-C1	1840 CFM	40' (12.2m)	1/2 HP	1	153 (69.4)	199 (90.3)	1301	16' (4.88 m)
AV-20A-A_	2930 CFM	40' (12.2m)	1/2 HP	1, 3 or 5	155 (70.3)	209 (94.8)	1499	18' (5.49 m)
AV-20A-B_	2700 CFM	40' (12.2m)	1/2 HP	1, 3 or 5	170 (77.1)	209 (94.8)	1382	18' (5.49 m)
AV-20A-C1	3000 CFM	40' (12.2m)	1/2 HP	1	195 (88.5)	242 (109.8)	1535	18' (5.49 m)
AV-24A-A_	3890 CFM	40' (12.2m)	1/2 HP	1, 3, 5 or 7	189 (85.7)	247 (112.0)	1288	20' (6.10 m)
AV-24A-B_	3640 CFM	40' (12.2m)	1/2 HP	1, 3, 5 or 7	212 (96.2)	251 (113.9)	1205	20' (6.10 m)
AV-24A-C1	3490 CFM	40' (12.2m)	1/2 HP	1	258 (117.0)	293 (132.9)	1115	20' (6.10 m)

See page 69 for model coding.

* at 70°F (21°C) at sea level.

† CCI Thermal Technology Inc. reserves the right to substitute motors of higher horsepower.

‡ Add 12 lbs to flanged units.

AH / AV

AH Physical Dimensions

DIM.	AH-12A	AH-16A	AH-20A	AH-24A
A in (mm)	15 ¹³ / ₁₆ (401)	19 ¹³ / ₁₆ (503)	23 ¹³ / ₁₆ (605)	27 ⁷ / ₈ (707)
B in (mm)	19 ⁷ / ₁₆ (494)	23 ¹ / ₂ (596)	27 ¹ / ₂ (698)	31 ¹ / ₂ (800)
C in (mm)	4 ³ / ₁₆ (107)	4 ³ / ₁₆ (107)	4 ³ / ₁₆ (107)	4 ³ / ₁₆ (107)
D in (mm)	7 ¹⁵ / ₁₆ (201)	7 ⁹ / ₁₆ (192)	7 ³ / ₁₆ (183)	6 ⁷ / ₈ (174)
E in (mm)	23 ⁵ / ₈ (600)	23 ⁵ / ₈ (600)	23 ⁵ / ₈ (600)	23 ⁵ / ₈ (600)
F in (mm)	18 ³ / ₁₆ (462)	22 ³ / ₁₆ (564)	26 ³ / ₁₆ (665)	30 ³ / ₁₆ (766)
G in (mm)	⁹ / ₁₆ (14.3)	⁹ / ₁₆ (14.3)	⁹ / ₁₆ (14.3)	⁹ / ₁₆ (14.3)
H in (mm)	23 ⁷ / ₈ (606.5)	27 ⁷ / ₈ (708.5)	31 ⁷ / ₈ (809.5)	35 ⁷ / ₈ (911.5)
I in (mm)	1 ⁹ / ₁₆ (39)	1 ⁹ / ₁₆ (39)	1 ⁹ / ₁₆ (39)	1 ⁹ / ₁₆ (39)
J in (mm)	⁵ / ₈ (16)	⁵ / ₈ (16)	⁵ / ₈ (16)	⁵ / ₈ (16)
K in (mm)	27 ¹ / ₂ (698.5)	31 ⁵ / ₈ (802.5)	35 ¹ / ₂ (903)	39 ⁵ / ₈ (1005)

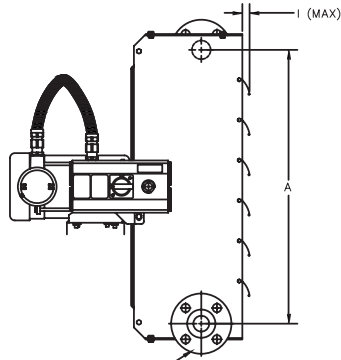
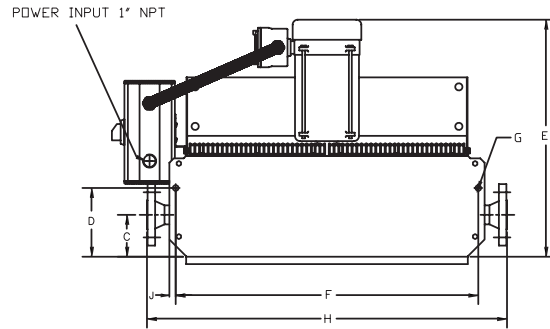

2" or 1¹/₂" 300# FLANGE
2" or 1¹/₂" NPT MALE

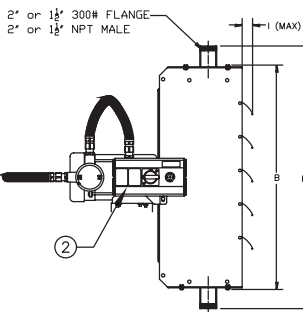
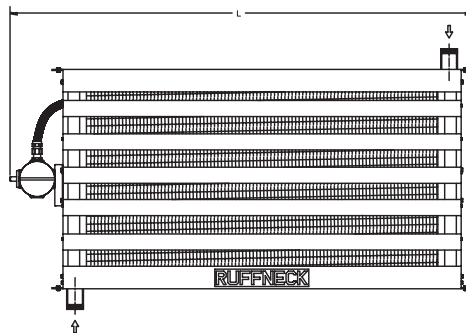
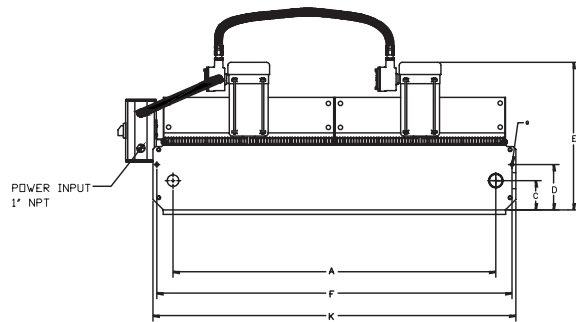
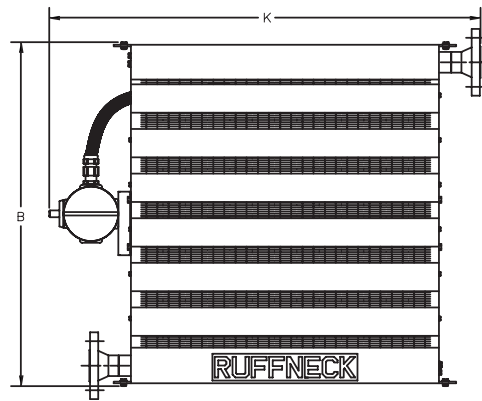

DIM.	AH-24B TANDEM
A in (mm)	52 ¹⁵ / ₁₆ (1345)
B in (mm)	31 ¹ / ₂ (800)
C in (mm)	4 ¹³ / ₁₆ (122)
D in (mm)	7 ⁷ / ₁₆ (189)
E in (mm)	24 ³ / ₁₆ (615)
F in (mm)	58 ¹ / ₄ (1480)
G in (mm)	⁹ / ₁₆ (14.3)
H in (mm)	36 ⁷ / ₈ (937)
I in (mm)	2 ¹ / ₁₆ (53)
J in (mm)	⁵ / ₈ (16)
K in (mm)	59 ¹ / ₂ (1512)
L in (mm)	65 ¹ / ₂ (1662.5)

AH / AV

AV Physical Dimensions

DIM.	AV-12A	AV-16A	AV-20A	AV-24A
A in (mm)	15 ¹³ / ₁₆ (401)	19 ¹³ / ₁₆ (503)	23 ¹³ / ₁₆ (605)	27 ⁷ / ₈ (707)
B in (mm)	19 ⁷ / ₁₆ (494)	23 ¹ / ₂ (596)	27 ¹ / ₂ (698)	31 ¹ / ₂ (800)
C in (mm)	4 ³ / ₁₆ (107)	4 ³ / ₁₆ (107)	4 ³ / ₁₆ (107)	4 ³ / ₁₆ (107)
D in (mm)	7 ¹⁵ / ₁₆ (201)	7 ⁹ / ₁₆ (192)	7 ³ / ₁₆ (183)	6 ⁷ / ₈ (174)
E in (mm)	23 ⁵ / ₈ (600)	23 ⁵ / ₈ (600)	23 ⁵ / ₈ (600)	23 ⁵ / ₈ (600)
F in (mm)	18 ³ / ₁₆ (462)	22 ³ / ₁₆ (564)	26 ³ / ₁₆ (665)	30 ³ / ₁₆ (766)
G in (mm)	9 ¹ / ₁₆ (14.3)	9 ¹ / ₁₆ (14.3)	9 ¹ / ₁₆ (14.3)	9 ¹ / ₁₆ (14.3)
H in (mm)	23 ⁷ / ₈ (606.5)	27 ⁷ / ₈ (708.5)	31 ⁷ / ₈ (809.5)	35 ⁷ / ₈ (911.5)
I in (mm)	1 ⁹ / ₁₆ (39)	1 ⁹ / ₁₆ (39)	1 ⁹ / ₁₆ (39)	1 ⁹ / ₁₆ (39)
J in (mm)	5 ⁵ / ₈ (16)	5 ⁵ / ₈ (16)	5 ⁵ / ₈ (16)	5 ⁵ / ₈ (16)
K in (mm)	11 ¹³ / ₁₆ (300)	11 ¹³ / ₁₆ (300)	15 ¹¹ / ₁₆ (398)	15 ¹¹ / ₁₆ (398)
L in (mm)	4 ¹⁵ / ₁₆ (122)	4 ¹⁵ / ₁₆ (122)	4 ¹⁵ / ₁₆ (122)	4 ¹⁵ / ₁₆ (122)

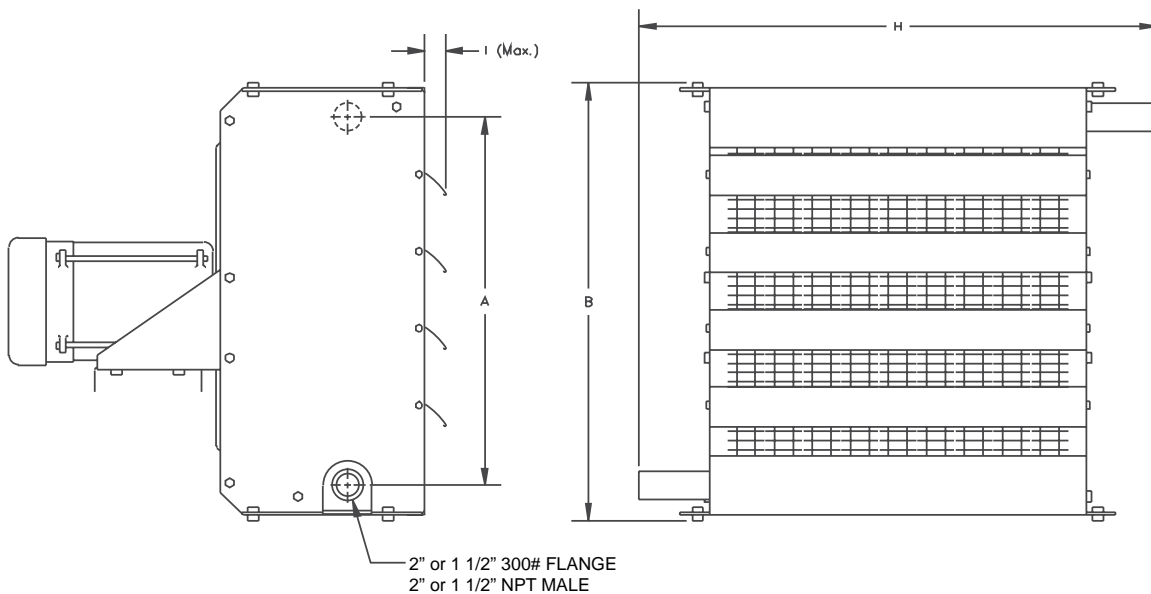
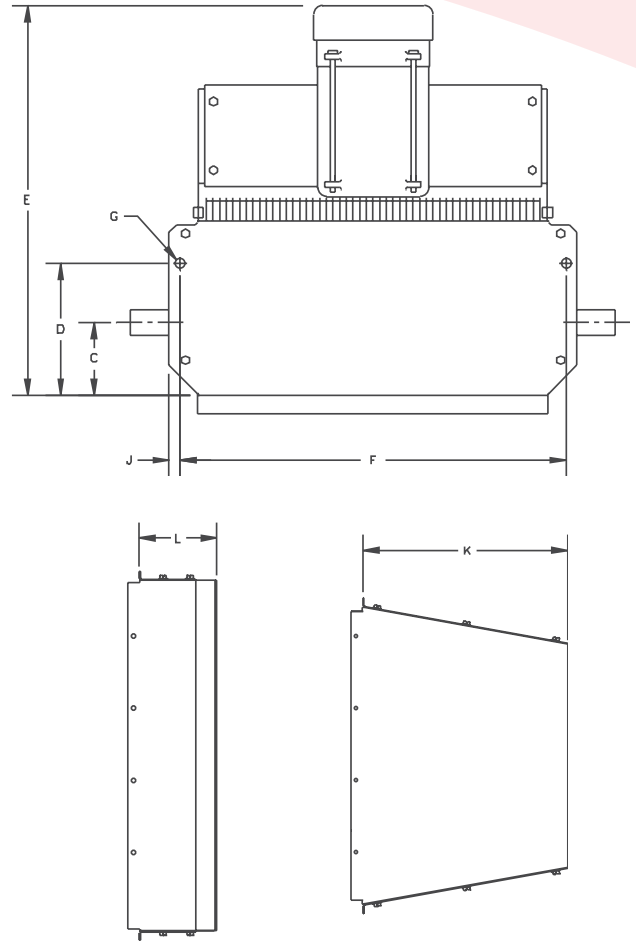

Model Coding

Base Model

Series Fan Heat Exchanger Cabinet Motor

AH - 12A - A 1 - 1 A - D

FAN SIZE	
12" (305 mm) DIA	12A
16" (406 mm) DIA	16A
20" (508 mm) DIA	20A
24" (610 mm) DIA	24A
24" (610 mm) tandem	24B

A = Standard single fan
B = Standard dual fan

TUBE MATERIAL						
TUBING	WALL THICKNESS	ROWS	FINNING			
			FINS/ INCH	MATERIAL	TYPE	
5/8" (16 mm)	.065" (1.7 mm)	3	10	AL	TW	A
1" (25 mm)	.083" (21 mm)	2	9	AL	EX	B
1" (25 mm)	.135" (3.4 mm)	2	5	AL	EX	C

TW = Tension Wound
EX = Extruded AL = Aluminum

PASSES	
1 Pass	1
3 Passes	3
5 Passes	5
7 Passes	7

CONNECTIONS	
1½" NPT Male Sch. 40	A
1½" (40 mm) 300# RF flange	B
2" NPT Male Sch. 80	C
2" (50 mm) 300# RF flange	D

EXCHANGER COATINGS	
Heat resistant aluminum paint	1
Heresite® phenolic coating	2

MOTOR ELECTRICAL SPECIFICATIONS			
	VOLTS	PHASE	HERTZ
A	115	1	60
B	208	1	60
C	208	3	60
D	230	1	60
E	230	3	60
F	460	1	60
G	460	3	60
H	575	3	60
I	220	1	50
J	380	3	50
K	440	3	50

Built-in Disconnect Switch

HEATER CERTIFICATION	
1	General Purpose
2	X-proof Motor only, groups C, D, E, F, & G
3	CSA Certified Heater

DISCHARGE TYPE	
1	2-way aluminum louvres
2	Nozzle
3	4-way aluminum louvres

CABINET MATERIAL	
A	Epoxy powder coated carbon steel
B	Heresite® phenolic coated carbon steel

Note:

CCI Thermal Technologies Inc. units utilize a standard motor. Specifying any other O.E.M Motor may result in longer lead times.

① Heresite® coated exchangers and cabinets: contact factory for quote.

② Louvres and fan blades are also Heresite® coated.

③ Contact factory for shipping lead time.

④ Motor designed to be used at rated voltage with tolerances of ±15%.

⑤ Motor may be marked 230V, but is suitable for 208V operation.

⑥ Tandem configuration not available on AV models.

⑦ 460 1 phase motors are only certified for groups D, F & G

⑧ Only available in 16" (406 mm) and larger units

⑨ Only available in 24" (610 mm) and larger units

⑩ Built-in Disconnect only available with CSA Certified heater

AH / AV



**5/8" (16 mm) Tension-Wound Finned Tubing
(10 fins/inch)**

AH-12A-A1 Single Pass

Operating Pressure		Entering Air Temperature °F (°C)						
		-10 (-23)	0 (-18)	20 (-7)	40 (4)	60 (16)	70 (21)	80 (27)
2	OUTPUT (MBH)	117.6	111.6	100.1	88.8	77.9	72.5	67.3
	COND. (lbs/hr)	120.1	114.0	102.2	90.7	79.5	74.1	68.7
	FAT °F (°C)	72.9 (22.7)	80.2 (26.8)	94.4 (34.7)	108.2 (42.3)	121.7 (49.8)	128.4 (53.6)	134.9 (57.2)
50	OUTPUT (MBH)	162.0	155.7	143.2	131.2	119.5	113.7	108.1
	COND. (lbs/hr)	175.1	168.2	154.7	141.7	129.0	122.8	116.7
	FAT °F (°C)	105.2 (40.7)	112.6 (44.8)	127.2 (52.7)	141.5 (60.8)	155.4 (68.6)	162.2 (72.3)	168.9 (76.1)
100	OUTPUT (MBH)	184.7	178.1	165.3	152.8	140.8	134.9	129.0
	COND. (lbs/hr)	206.3	198.9	184.5	170.6	157.1	150.5	143.9
	FAT °F (°C)	121.8 (49.9)	129.4 (54.1)	144.2 (62.3)	158.7 (70.4)	172.8 (78.2)	179.7 (82.1)	186.5 (85.8)
200	OUTPUT (MBH)	213.0	206.2	192.8	179.9	167.4	161.2	155.2
	COND. (lbs/hr)	249.1	241.1	225.4	210.3	195.6	188.4	181.3
	FAT °F (°C)	142.6 (61.4)	150.4 (65.8)	165.5 (74.2)	180.3 (82.4)	194.7 (90.4)	201.7 (94.3)	208.7 (98.2)



**1" (25 mm) Extruded Finned Tubing
(9 fins/inch)**

AH-12A-B1 Single Pass

Operating Pressure		Entering Air Temperature °F (°C)						
		-10 (-23)	0 (-18)	20 (-7)	40 (4)	60 (16)	70 (21)	80 (27)
2	OUTPUT (MBH)	110.0	104.5	93.7	83.2	73.0	68.0	63.0
	COND. (lbs/hr)	112.2	160.6	95.6	84.9	74.5	69.4	64.3
	FAT °F (°C)	66.9 (19.4)	74.3 (23.5)	88.9 (31.6)	103.2 (39.6)	117.2 (47.3)	124.1 (51.2)	130.9 (54.9)
50	OUTPUT (MBH)	151.7	145.8	134.2	123.0	112.0	106.7	101.4
	COND. (lbs/hr)	163.8	157.8	144.8	132.7	120.9	115.1	109.4
	FAT °F (°C)	96.8 (36)	104.4 (40.2)	119.4 (48.6)	134.1 (56.7)	148.4 (64.7)	155.4 (68.6)	162.4 (72.4)
100	OUTPUT (MBH)	173.1	166.9	155.0	143.4	132.1	126.6	121.1
	COND. (lbs/hr)	193.1	186.2	172.8	159.8	147.2	141.1	135.0
	FAT °F (°C)	112.2 (44.6)	119.9 (48.8)	135.1 (52.3)	150.0 (65.6)	164.5 (73.6)	171.7 (77.6)	178.7 (81.5)
200	OUTPUT (MBH)	199.7	193.3	180.9	168.8	157.1	151.4	145.8
	COND. (lbs/hr)	233.3	225.8	211.2	197.1	183.4	176.7	170.1
	FAT °F (°C)	131.5 (55.3)	139.4 (59.7)	154.9 (68.3)	170.1 (76.7)	184.8 (84.4)	192.1 (88.9)	199.3 (92.9)



**1" (25 mm) Extruded Finned Tubing
(5 fins/inch)**

AH-12A-C1 Single Pass

Operating Pressure		Entering Air Temperature °F (°C)						
		-10 (-23)	0 (-18)	20 (-7)	40 (4)	60 (16)	70 (21)	80 (27)
2	OUTPUT (MBH)	88.2	83.8	75.1	66.7	58.5	54.5	50.5
	COND. (lbs/hr)	89.7	85.1	76.3	67.8	59.4	55.4	51.3
	FAT °F (°C)	59.1 (15.1)	66.8 (19.3)	77.8 (22.0)	86.1 (30.6)	94.2 (34.6)	101.7 (38.2)	108.4 (42.4)
50	OUTPUT (MBH)	121.4	116.7	107.4	98.4	89.6	85.3	81.1
	COND. (lbs/hr)	130.5	125.4	115.4	105.7	96.3	91.7	87.7
	FAT °F (°C)	85.6 (29.8)	93.5 (34.2)	102.8 (39.3)	111.3 (45.2)	119.6 (50.3)	127.7 (53.2)	135.6 (57.6)
100	OUTPUT (MBH)	138.4	133.5	123.9	114.6	105.6	101.2	96.9
	COND. (lbs/hr)	153.7	148.3	137.6	127.2	117.2	112.3	107.4
	FAT °F (°C)	99.2 (37.3)	107.3 (41.8)	116.0 (47.2)	124.3 (51.8)	132.6 (55.9)	140.7 (60.4)	148.6 (65.3)
200	OUTPUT (MBH)	159.6	154.5	144.6	135.0	125.6	121.1	116.6
	COND. (lbs/hr)	185.6	179.7	168.1	156.8	145.9	140.6	135.6
	FAT °F (°C)	116.3 (46.8)	124.5 (51.4)	133.2 (56.8)	141.3 (61.8)	149.3 (66.3)	157.1 (70.6)	164.8 (74.9)

For 50 Hz power supply, derate output by 10%. For model coding, refer to page 69. Above figures are based on calculations at sea level.
COND. = Condensate Flow. FAT = Final Air Temperature.



5/8" (16 mm) Tension-Wound Finned Tubing
(10 fins/inch)

AH-16A-A1 Single Pass

Operating Pressure		Entering Air Temperature °F (°C)						
		-10 (-23)	0 (-18)	20 (-7)	40 (4)	60 (16)	70 (21)	80 (27)
2	OUTPUT (MBH)	194.3	184.5	165.3	146.7	128.6	119.7	111.0
	COND. (lbs/hr)	199.0	188.9	169.3	150.2	131.7	122.6	113.7
	FAT °F (°C)	75.9 (24.4)	83.0 (28.3)	97.0 (36.1)	110.6 (43.7)	123.8 (51)	130.4 (54.7)	138.8 (59.3)
50	OUTPUT (MBH)	267.6	257.0	236.4	216.4	197.0	187.6	178.0
	COND. (lbs/hr)	290.0	278.6	256.2	234.5	213.5	203.2	193.0
	FAT °F (°C)	109.2 (42.9)	116.6 (47.0)	131.0 (55.0)	145.0 (62.8)	158.6 (70.3)	165.3 (74.1)	171.9 (77.7)
100	OUTPUT (MBH)	305.0	294.0	272.7	252.1	232.1	222.3	212.7
	COND. (lbs/hr)	341.7	329.4	305.5	282.3	259.9	248.9	238.1
	FAT °F (°C)	126.4 (52.4)	133.9 (56.6)	148.5 (64.7)	162.8 (72.7)	176.6 (80.3)	183.4 (84.1)	190.1 (87.8)
200	OUTPUT (MBH)	351.5	340.2	318.0	296.6	275.9	265.7	255.7
	COND. (lbs/hr)	412.6	399.2	373.2	348.0	323.6	311.6	299.9
	FAT °F (°C)	148.0 (64.4)	155.6 (68.7)	170.6 (77)	185.1 (85.1)	199.3 (92.9)	206.2 (96.8)	213.0 (100.1)



1" Extruded Finned Tubing
(9 fins/inch)

AH-16A-B1 Single Pass

Operating Pressure		Entering Air Temperature °F (°C)						
		-23 (-10)	0 (-18)	20 (-7)	40 (4)	60 (16)	70 (21)	80 (27)
2	OUTPUT (MBH)	182.5	173.3	155.2	137.7	120.7	112.4	104.2
	COND. (lbs/hr)	186.8	177.4	158.9	141.0	123.5	115.0	106.6
	FAT °F (°C)	73.2 (22.9)	80.4 (26.9)	94.5 (34.7)	108.3 (42.4)	121.8 (49.9)	128.4 (53.6)	135.0 (57.2)
50	OUTPUT (MBH)	251.5	241.5	222.1	203.3	185.0	176.1	167.3
	COND. (lbs/hr)	272.4	261.6	240.5	220.1	200.3	190.6	181.1
	FAT °F (°C)	105.4 (40.8)	112.8 (44.9)	127.4 (53)	141.6 (60.9)	155.4 (68.6)	162.2 (72.3)	168.9 (76.1)
100	OUTPUT (MBH)	286.7	276.4	256.3	236.9	218.0	208.8	199.8
	COND. (lbs/hr)	321.0	309.4	286.9	265.1	243.9	233.6	223.4
	FAT °F (°C)	122.0 (50.0)	129.6 (54.2)	144.4 (62.4)	158.8 (70.4)	172.8 (78.2)	179.7 (82.1)	186.5 (85.8)
200	OUTPUT (MBH)	330.6	319.9	299.0	278.8	259.2	249.7	240.3
	COND. (lbs/hr)	387.7	375.1	350.5	326.8	303.8	292.6	281.5
	FAT °F (°C)	142.9 (61.6)	150.6 (65.9)	165.6 (74.2)	180.3 (82.4)	194.7 (90.4)	201.7 (94.3)	208.6 (98.1)



1" Extruded Finned Tubing
(5 fins/inch)

AH-16A-C1 Single Pass

Operating Pressure		Entering Air Temperature °F (°C)						
		-10 (-23)	0 (-18)	20 (-7)	40 (4)	60 (16)	70 (21)	80 (27)
2	OUTPUT (MBH)	146.4	139.1	124.7	110.8	97.2	90.6	84.0
	COND. (lbs/hr)	149.5	142.0	127.3	113.1	99.2	92.4	85.7
	FAT °F (°C)	54.1 (12.3)	61.9 (16.6)	77.5 (25.3)	92.8 (33.8)	107.8 (72.1)	115.3 (46.3)	122.6 (50.3)
50	OUTPUT (MBH)	201.4	193.5	178.2	163.3	148.8	141.7	134.7
	COND. (lbs/hr)	217.4	208.9	192.3	176.2	160.6	152.9	145.4
	FAT °F (°C)	78.5 (25.8)	86.6 (30.3)	102.5 (39.2)	118.2 (47.9)	133.6 (56.4)	141.1 (60.6)	148.7 (64.8)
100	OUTPUT (MBH)	229.5	221.4	205.5	190.2	175.3	168.0	160.8
	COND. (lbs/hr)	256.0	247.0	229.3	212.1	195.5	187.3	179.3
	FAT °F (°C)	91.1 (32.8)	99.3 (37.4)	115.4 (46.3)	131.3 (55.2)	146.8 (63.8)	154.5 (68.1)	162.1 (72.3)
200	OUTPUT (MBH)	264.5	256.1	239.7	223.8	208.4	200.8	193.4
	COND. (lbs/hr)	309.1	299.2	280.0	261.3	243.3	234.4	225.7
	FAT °F (°C)	106.9 (41.6)	115.2 (46.2)	131.6 (55.3)	147.7 (64.3)	163.5 (73.1)	171.3 (77.4)	179.0 (81.7)

For 50 Hz power supply, derate output by 10%. For model coding, refer to page 69. Above figures are based on calculations at sea level.
COND. = Condensate Flow. FAT = Final Air Temperature.



**5/8" (16 mm) Tension-Wound Finned Tubing
(10 fins/inch)**

AH-20A-A1 Single Pass

Operating Pressure		Entering Air Temperature °F (°C)						
		-10 (-23)	0 (-18)	20 (-7)	40 (4)	60 (16)	70 (21)	80 (27)
2	OUTPUT (MBH)	285.6	271.2	243.1	215.9	189.3	176.3	163.5
	COND. (lbs/hr)	293.0	278.3	249.5	221.5	194.2	180.9	167.7
	FAT °F (°C)	20.8 (69.4)	76.8 (24.9)	91.3 (32.9)	105.4 (40.8)	119.2 (48.4)	126.0 (52.2)	132.7 (55.9)
50	OUTPUT (MBH)	392.5	377.1	347.0	317.9	289.5	275.7	262.0
	COND. (lbs/hr)	426.3	409.5	376.8	345.1	314.3	299.2	284.4
	FAT °F (°C)	100.0 (37.8)	107.6 (42.0)	122.5 (50.3)	137.0 (58.3)	151.2 (66.2)	158.2 (70.1)	165.1 (73.9)
100	OUTPUT (MBH)	447.1	431.2	400.1	370.0	340.8	326.6	312.5
	COND. (lbs/hr)	501.9	484.0	449.1	415.3	382.5	366.4	350.6
	FAT °F (°C)	115.8 (46.6)	123.5 (50.8)	138.6 (59.2)	153.4 (67.4)	167.8 (75.4)	174.8 (79.3)	181.8 (83.2)
200	OUTPUT (MBH)	514.9	498.4	466.2	435.0	404.8	390.0	375.4
	COND. (lbs/hr)	605.8	586.3	548.3	511.5	475.9	458.5	441.3
	FAT °F (°C)	135.5 (57.5)	143.4 (61.9)	158.8 (70.4)	173.9 (78.8)	188.6 (87.0)	195.8 (91.0)	202.9 (94.9)



**1" (25 mm) Extruded Finned Tubing
(9 fins/inch)**

AH-20A-B1 Single Pass

Operating Pressure		Entering Air Temperature °F (°C)						
		-10 (-23)	0 (-18)	20 (-7)	40 (4)	60 (16)	70 (21)	80 (27)
2	OUTPUT (MBH)	283.4	269.0	240.8	213.5	187.1	174.1	161.4
	COND. (lbs/hr)	209.8	276.0	247.1	219.1	191.9	178.6	165.6
	FAT °F (°C)	74.8 (23.8)	81.9 (27.7)	96.0 (35.6)	109.7 (43.2)	123.0 (50.5)	129.6 (54.2)	136.1 (57.8)
50	OUTPUT (MBH)	390.6	375.0	344.6	315.2	286.8	272.9	259.2
	COND. (lbs/hr)	424.1	407.2	374.1	342.2	311.3	296.2	281.3
	FAT °F (°C)	107.6 (42.0)	115.0 (46.1)	129.4 (54.1)	143.5 (61.9)	157.3 (69.6)	164.0 (73.3)	170.6 (77.0)
100	OUTPUT (MBH)	445.3	429.2	397.7	367.3	337.9	323.6	309.4
	COND. (lbs/hr)	499.9	481.7	446.4	412.2	379.2	363.0	347.2
	FAT °F (°C)	124.5 (51.4)	132.0 (55.6)	146.7 (63.5)	161.0 (71.7)	175.0 (79.4)	181.8 (83.2)	188.6 (87.0)
200	OUTPUT (MBH)	513.5	496.7	464.0	432.4	401.8	386.9	372.2
	COND. (lbs/hr)	604.1	584.2	545.6	508.4	472.3	454.8	437.5
	FAT °F (°C)	145.7 (63.2)	153.4 (67.4)	168.4 (75.8)	183.0 (83.9)	197.2 (91.8)	204.2 (95.7)	211.1 (99.5)



**1" (25 mm) Extruded Finned Tubing
(5 fins/inch)**

AH-20A-C1 Single Pass

Operating Pressure		Entering Air Temperature °F (°C)						
		-10 (-23)	0 (-18)	20 (-7)	40 (4)	60 (16)	70 (21)	80 (27)
2	OUTPUT (MBH)	224.9	213.6	191.7	170.3	149.5	139.3	129.2
	COND. (lbs/hr)	230.2	218.7	196.2	174.3	153.0	142.5	132.2
	FAT °F (°C)	50.6 (10.3)	14.8 (58.6)	74.4 (23.6)	90.0 (32.2)	105.3 (40.7)	112.9 (44.9)	120.4 (49.1)
50	OUTPUT (MBH)	309.2	297.2	273.7	250.9	228.7	217.9	207.2
	COND. (lbs/hr)	334.9	321.8	296.4	271.6	247.6	235.9	224.2
	FAT °F (°C)	73.7 (23.2)	27.7 (81.9)	98.1 (36.7)	114.0 (45.6)	129.7 (52.3)	137.4 (58.6)	145.0 (62.8)
100	OUTPUT (MBH)	352.2	339.8	315.6	292.2	269.4	258.2	247.2
	COND. (lbs/hr)	394.3	380.4	353.3	326.9	301.4	288.9	276.5
	FAT °F (°C)	85.6 (29.8)	34.4 (93.9)	110.3 (43.5)	126.4 (52.4)	142.2 (61.2)	150.0 (65.6)	157.8 (69.9)
200	OUTPUT (MBH)	405.9	393.0	368.0	343.7	320.1	308.6	297.2
	COND. (lbs/hr)	476.0	460.9	431.4	402.8	375.1	361.6	348.2
	FAT °F (°C)	100.5 (38.1)	108.9 (42.7)	125.6 (52.0)	141.9 (61.1)	158.0 (70.0)	165.9 (74.4)	173.8 (78.8)

For 50 Hz power supply, derate output by 10%. For model coding, refer to page 69. Above figures are based on calculations at sea level.
COND. = Condensate Flow. FAT = Final Air Temperature.



**5/8" (16 mm) Tension-Wound Finned Tubing
(10 fins/inch)**

AH-24A-A1 Single Pass

Operating Pressure		Entering Air Temperature °F (°C)						
		-10 (-23)	0 (-18)	20 (-7)	40 (4)	60 (16)	70 (21)	80 (27)
2	OUTPUT (MBH)	390.0	370.4	332.0	294.6	258.4	240.6	223.0
	COND. (lbs/hr)	399.6	379.4	340.0	301.8	264.6	246.4	228.4
	FAT °F (°C)	71.5 (21.9)	78.8 (26.0)	93.1 (33.9)	107.0 (41.7)	120.7 (49.3)	127.4 (53.0)	134.0 (56.7)
50	OUTPUT (MBH)	536.0	514.9	473.7	433.8	395.0	376.1	357.4
	COND. (lbs/hr)	581.1	558.2	513.4	470.1	428.1	407.5	387.2
	FAT °F (°C)	102.8 (39.3)	110.3 (43.5)	125.1 (51.7)	139.4 (59.7)	153.4 (67.4)	160.3 (71.3)	167.1 (75.1)
100	OUTPUT (MBH)	610.5	588.7	546.2	505.0	465.0	445.4	426.2
	COND. (lbs/hr)	684.1	659.6	611.8	565.6	520.8	498.9	477.3
	FAT °F (°C)	119.0 (48.3)	126.6 (52.6)	141.6 (69.0)	156.2 (69.0)	170.4 (76.9)	177.4 (80.8)	184.3 (84.6)
200	OUTPUT (MBH)	703.1	680.5	636.4	593.7	552.3	532.1	512.1
	COND. (lbs/hr)	825.5	798.8	746.9	696.6	647.9	624.1	600.7
	FAT °F (°C)	139.2 (59.6)	147.0 (63.9)	162.3 (72.4)	177.2 (80.7)	191.7 (88.7)	198.8 (92.7)	205.9 (96.6)



**1" (25 mm) Extruded Finned Tubing
(9 fins/inch)**

AH-24A-B1 Single Pass

Operating Pressure		Entering Air Temperature °F (°C)						
		-10 (-23)	0 (-18)	20 (-7)	40 (4)	60 (16)	70 (21)	80 (27)
2	OUTPUT (MBH)	353.9	336.0	300.9	266.9	233.9	217.8	202.8
	COND. (lbs/hr)	362.2	343.8	307.9	273.1	239.3	222.8	206.5
	FAT °F (°C)	68.4 (20.2)	75.7 (24.8)	90.3 (32.4)	104.5 (40.3)	118.3 (47.9)	125.2 (51.8)	131.9 (55.5)
50	OUTPUT (MBH)	486.6	467.3	429.6	393.2	357.9	340.6	323.6
	COND. (lbs/hr)	526.9	505.9	465.1	425.6	387.3	368.6	350.1
	FAT °F (°C)	98.4 (36.9)	106.0 (41.1)	120.9 (49.4)	135.5 (57.5)	149.8 (65.4)	156.8 (69.3)	163.7 (73.2)
100	OUTPUT (MBH)	554.4	534.4	495.5	457.9	421.4	403.6	386.1
	COND. (lbs/hr)	620.5	598.0	554.4	512.2	471.3	451.4	431.7
	FAT °F (°C)	113.8 (45.4)	121.5 (49.7)	136.7 (58.2)	151.5 (66.4)	166.0 (74.4)	173.1 (78.4)	180.1 (82.3)
200	OUTPUT (MBH)	638.9	618.1	577.7	538.6	500.8	482.3	464.2
	COND. (lbs/hr)	749.0	724.6	677.0	631.1	586.7	565.0	543.6
	FAT °F (°C)	133.2 (56.2)	141.1 (60.6)	156.5 (69.2)	171.6 (77.6)	186.4 (85.8)	193.6 (89.8)	200.8 (93.8)



**1" (25 mm) Extruded Finned Tubing
(5 fins/inch)**

AH-24A-C1 Single Pass

Operating Pressure		Entering Air Temperature °F (°C)						
		-10 (-23)	0 (-18)	20 (-7)	40 (4)	60 (16)	70 (21)	80 (27)
2	OUTPUT (MBH)	290.8	276.2	247.6	219.9	192.9	179.6	166.6
	COND. (lbs/hr)	296.9	281.9	252.7	224.4	196.8	183.3	170.0
	FAT °F (°C)	57.2 (14.0)	65.0 (18.3)	80.3 (26.8)	95.3 (35.2)	110.1 (43.4)	117.4 (47.4)	124.6 (51.4)
50	OUTPUT (MBH)	399.3	383.6	353.1	323.4	294.7	280.6	266.7
	COND. (lbs/hr)	431.1	414.1	381.1	349.1	318.0	302.8	287.7
	FAT °F (°C)	82.7 (28.2)	90.7 (32.6)	106.4 (41.3)	121.8 (49.9)	136.9 (58.8)	144.4 (62.4)	151.8 (66.6)
100	OUTPUT (MBH)	454.6	438.5	407.0	376.5	346.9	332.4	318.1
	COND. (lbs/hr)	507.3	489.2	453.9	419.8	386.7	370.5	354.6
	FAT °F (°C)	95.9 (35.5)	103.9 (39.9)	119.9 (48.8)	135.5 (57.5)	150.8 (66.0)	158.3 (70.2)	165.8 (74.3)
200	OUTPUT (MBH)	523.6	506.9	474.2	442.7	412.0	397.0	382.3
	COND. (lbs/hr)	611.9	592.3	554.0	516.9	481.0	463.5	446.2
	FAT °F (°C)	112.3 (44.6)	120.5 (49.2)	136.7 (58.2)	152.6 (67.0)	168.1 (75.6)	175.8 (79.9)	183.4 (84.1)

For 50 Hz power supply, derate output by 10%. For model coding, refer to page 69. Above figures are based on calculations at sea level.
COND. = Condensate Flow. FAT = Final Air Temperature.



**5/8" (16 mm) Tension-Wound Finned Tubing
(10 fins/inch)**

AH-24B-A1 Single Pass

Operating Pressure		Entering Air Temperature °F (°C)						
		-10 (-23)	0 (-18)	20 (-7)	40 (4)	60 (16)	70 (21)	80 (27)
2	OUTPUT (MBH)	694.1	659.3	591.1	524.8	460.4	428.8	397.6
	COND. (lbs/hr)	713.3	677.5	607.4	539.3	473.1	440.6	408.5
	FAT °F (°C)	63.8 (17.7)	71.3 (21.8)	86.2 (30.1)	100.8 (38.2)	115.0 (46.1)	122.1 (50.1)	129.0 (53.9)
50	OUTPUT (MBH)	951.4	914.1	841.3	770.7	702.2	668.6	635.4
	COND. (lbs/hr)	1035.0	994.4	915.2	838.3	763.7	727.1	691.0
	FAT °F (°C)	91.9 (32.3)	99.7 (37.6)	114.9 (46.1)	129.9 (54.4)	144.6 (62.6)	151.8 (66.6)	158.9 (70.5)
100	OUTPUT (MBH)	1082.5	1044.1	969.1	896.4	825.8	791.3	757.2
	COND. (lbs/hr)	1217.6	1174.3	1089.8	1007.9	928.5	889.6	851.2
	FAT °F (°C)	106.3 (41.3)	114.2 (45.7)	129.7 (54.3)	144.9 (62.7)	159.8 (71.0)	167.1 (75.1)	174.3 (79.1)
200	OUTPUT (MBH)	1245.6	1205.7	1128.1	1052.8	979.9	944.2	909.0
	COND. (lbs/hr)	1468.2	1421.1	1329.4	1240.5	1154.4	1112.3	1070.7
	FAT °F (°C)	124.4 (51.3)	132.5 (55.8)	148.3 (64.6)	163.8 (73.2)	178.9 (81.6)	186.4 (85.8)	193.7 (89.8)



**1" (25 mm) Extruded Finned Tubing
(9 fins/inch)**

AH-24B-B1 Single Pass

Operating Pressure		Entering Air Temperature °F (°C)						
		-10 (-23)	0 (-18)	20 (-7)	40 (4)	60 (16)	70 (21)	80 (27)
2	OUTPUT (MBH)	637.6	605.5	542.8	481.8	422.6	393.6	364.9
	COND. (lbs/hr)	654.9	621.9	557.4	494.8	434.0	404.2	374.7
	FAT °F (°C)	59.7 (15.4)	67.4 (19.7)	82.5 (28.1)	97.4 (36.3)	112.0 (44.4)	119.2 (48.4)	126.3 (52.4)
50	OUTPUT (MBH)	874.3	839.9	772.9	707.9	644.8	614.0	583.5
	COND. (lbs/hr)	950.4	913.0	840.1	769.4	700.8	667.2	634.1
	FAT °F (°C)	86.2 (30.1)	94.1 (34.5)	109.6 (43.1)	124.8 (51.6)	139.8 (59.9)	147.1 (63.9)	154.4 (68.0)
100	OUTPUT (MBH)	994.9	959.5	890.4	823.5	758.5	726.8	695.5
	COND. (lbs/hr)	1118.2	1078.3	1000.5	925.2	852.2	816.4	781.2
	FAT °F (°C)	99.8 (37.7)	107.8 (42.1)	123.5 (50.8)	139.0 (59.4)	154.1 (67.8)	161.6 (72.0)	169.0 (76.1)
200	OUTPUT (MBH)	1147.2	1108.4	1036.8	967.5	900.3	867.5	835.1
	COND. (lbs/hr)	1348.7	1305.3	1220.8	1139.0	1059.8	1021.1	982.9
	FAT °F (°C)	116.8 (47.1)	125.0 (51.7)	141.0 (60.6)	156.7 (69.3)	172.1 (77.8)	179.7 (82.4)	187.2 (86.2)



**1" (25 mm) Extruded Finned Tubing
(5 fins/inch)**

AH-24B-C1 Single Pass

Operating Pressure		Entering Air Temperature °F (°C)						
		-10 (-23)	0 (-18)	20 (-7)	40 (4)	60 (16)	70 (21)	80 (27)
2	OUTPUT (MBH)	499.4	474.3	425.3	377.7	331.4	308.7	286.3
	COND. (lbs/hr)	511.8	486.1	435.8	387.1	339.6	316.3	293.4
	FAT °F (°C)	50.3 (10.2)	58.3 (14.6)	74.1 (23.4)	89.7 (32.1)	105.5 (40.8)	112.6 (44.8)	120.1 (48.9)
50	OUTPUT (MBH)	683.6	656.8	604.7	554.1	504.9	480.9	457.1
	COND. (lbs/hr)	741.3	712.2	655.6	600.7	547.4	521.2	495.5
	FAT °F (°C)	73.0 (22.8)	81.2 (27.3)	97.4 (36.3)	113.3 (45.2)	128.9 (53.8)	136.7 (58.2)	144.4 (62.4)
100	OUTPUT (MBH)	777.5	750.5	696.3	644.2	593.7	569.0	544.6
	COND. (lbs/hr)	871.5	840.6	780.3	721.9	665.2	637.4	610.1
	FAT °F (°C)	84.6 (29.2)	92.9 (33.8)	109.3 (42.9)	125.4 (51.9)	141.3 (60.7)	149.1 (65.1)	156.9 (69.4)
200	OUTPUT (MBH)	894.4	865.9	810.4	756.6	704.4	678.9	653.8
	COND. (lbs/hr)	1050.4	1016.9	951.5	888.1	826.8	796.7	767.1
	FAT °F (°C)	99.1 (37.3)	107.6 (42.0)	124.2 (51.2)	140.6 (60.3)	156.7 (69.3)	164.6 (73.7)	172.5 (78.1)

For 50 Hz power supply, derate output by 10%. For model coding, refer to page 69. Above figures are based on calculations at sea level.
COND. = Condensate Flow. FAT = Final Air Temperature.

		ENTERING GLYCOL TEMPERATURE											
		180°F (82°C)				200°F (93°C)				220°F (104°C)			
MODEL	ΔT °F (°C)	OUTPUT MBH	FLOW USGPM	FAT °F (°C)	PD PSI	OUTPUT MBH	FLOW USGPM	FAT °F (°C)	PD PSI	OUTPUT MBH	FLOW USGPM	FAT °F (°C)	PD PSI
AH-12A-A1* <i>One pass</i>	10 (5.6)	17.6	3.69	73.3 (22.9)	0.00	21.5	4.45	76.3 (24.6)	0.00	33.6	6.95	85.8 (29.9)	0.01
	20 (11.1)	13.0	1.35	69.7 (20.9)	0.00	16.1	1.65	72.0 (22.2)	0.00	19.3	1.95	74.4 (23.6)	0.00
	40 (22.2)	8.9	0.45	66.4 (19.1)	0.00	11.2	0.56	68.1 (20.1)	0.00	13.6	0.68	69.9 (21.1)	0.00
AH-12A-A3 <i>Three pass</i>	10 (5.6)	43.0	9.26	93.7 (34.3)	0.31	56.5	12.0	104.5 (40.3)	0.52	68.1	14.3	113.7 (45.4)	0.73
	20 (11.1)	19.0	2.00	74.4 (23.6)	0.02	34.0	3.59	86.3 (30.2)	0.05	48.8	5.12	98.1 (36.7)	0.10
	40 (22.2)	13.3	0.69	69.9 (21.1)	0.00	16.7	0.86	72.5 (22.5)	0.00	20.4	1.04	75.3 (24.1)	0.01
AH-16A-A1* <i>One pass</i>	10 (5.6)	32.1	6.82	75.4 (24.1)	0.01	54.3	11.5	86.4 (30.2)	0.01	80.0	16.8	99.2 (37.3)	0.03
	20 (11.1)	24.0	2.53	71.4 (21.9)	0.00	29.6	3.09	74.1 (23.4)	0.00	35.4	3.65	76.9 (24.9)	0.00
	40 (22.2)	15.8	0.82	67.3 (19.6)	0.00	20.7	1.06	69.6 (20.9)	0.00	25.1	1.28	71.7 (22.1)	0.00
AH-16A-A3 <i>Three pass</i>	10 (5.6)	80.3	17.4	99.5 (37.5)	0.74	99.2	21.2	109.0 (42.8)	1.08	118.1	24.9	118.5 (48.1)	1.48
	20 (11.1)	48.6	5.23	83.6 (28.7)	0.08	72.5	7.73	95.5 (35.3)	0.16	97.3	10.3	107.9 (42.2)	0.27
	40 (22.2)	24.3	1.29	71.5 (21.9)	0.01	30.6	1.61	74.6 (23.7)	0.01	37.2	1.93	77.7 (25.4)	0.01
AH-16A-A5 <i>Five pass</i>	10 (5.6)	88.0	19.1	103.4 (39.7)	3.96	106.7	22.8	112.8 (44.9)	5.60	125.3	26.5	122.2 (50.1)	7.46
	20 (11.1)	69.0	7.46	93.8 (34.3)	0.65	90.9	9.73	104.8 (40.4)	1.08	109.9	11.6	114.3 (45.7)	1.52
	40 (22.2)	28.6	1.53	73.7 (23.2)	0.03	49.5	2.63	84.0 (28.9)	0.09	74.5	3.94	96.4 (35.8)	0.19
AH-20A-A1* <i>One pass</i>	10 (5.6)	61.1	13.1	78.7 (25.9)	0.01	101.6	21.7	91.3 (32.9)	0.03	134.4	28.4	101.6 (38.7)	0.05
	20 (11.1)	40.7	4.34	72.3 (22.4)	0.00	50.1	5.28	75.2 (24.0)	0.00	59.9	6.24	78.1 (25.6)	0.00
	40 (22.2)	25.0	1.32	67.4 (19.7)	0.00	35.0	1.83	70.4 (21.3)	0.00	43.1	2.23	72.9 (22.7)	0.00
AH-20A-A3 <i>Three pass</i>	10 (5.6)	123.0	26.7	98.2 (26.8)	1.09	150.4	32.2	106.8 (41.6)	1.56	177.7	37.6	115.5 (46.4)	3.09
	20 (11.1)	86.9	9.41	86.8 (30.4)	0.15	118.5	12.7	96.7 (35.9)	0.26	151.7	16.07	107.2 (41.8)	0.41
	40 (22.2)	40.8	2.19	72.3 (22.4)	0.01	51.3	2.72	75.5 (24.2)	0.02	79.8	4.21	84.4 (29.1)	0.03
AH-20A-A5 <i>Five pass</i>	10 (5.6)	132.3	28.7	101.2 (38.4)	5.58	159.4	34.2	109.7 (43.2)	7.77	186.4	39.5	118.2 (47.9)	10.3
	20 (11.1)	111.6	12.1	94.6 (34.8)	1.07	139.3	14.9	103.3 (39.6)	1.59	166.8	17.7	112.0 (44.4)	2.18
	40 (22.2)	49.4	2.66	75.0 (23.9)	0.06	91.1	4.89	88.0 (31.1)	0.19	123.6	6.57	98.2 (26.8)	0.33
AH-24A-A1* <i>One pass</i>	10 (5.6)	110.2	23.7	85.4 (29.7)	0.03	156.3	33.3	96.3 (35.7)	0.06	205.1	43.2	107.8 (42.1)	0.09
	20 (11.1)	60.0	6.37	73.6 (23.1)	0.00	73.8	7.75	76.7 (24.8)	0.00	87.7	9.01	79.9 (26.6)	0.01
	40 (22.2)	35.1	1.83	67.8 (19.9)	0.00	49.2	2.56	71.0 (21.7)	0.00	64.0	3.30	74.3 (23.5)	0.00
AH-24A-A3 <i>Three pass</i>	10 (5.6)	173.0	37.4	100.4 (38.0)	1.68	210.1	44.9	109.1 (42.8)	2.37	247.1	52.2	117.9 (47.7)	3.15
	20 (11.1)	131.7	14.2	90.5 (32.5)	0.27	177.5	19.0	101.3 (38.5)	0.46	215.4	22.8	110.3 (43.5)	0.64
	40 (22.2)	59.8	3.20	73.6 (23.1)	0.02	74.0	3.91	76.8 (24.9)	0.03	137.5	7.26	91.7 (33.2)	0.08
AH-24A-A5 <i>Five pass</i>	10 (5.6)	183.8	39.8	103.0 (39.4)	8.39	220.5	47.2	111.7 (44.3)	11.6	—	—	—	—
	20 (11.1)	158.3	17.2	96.9 (36.1)	1.68	195.7	21.0	105.7 (40.9)	2.45	233.0	24.7	114.5 (45.8)	3.32
	40 (22.2)	93.2	5.04	81.4 (27.4)	0.17	139.6	7.48	92.3 (33.5)	0.35	187.1	9.94	103.5 (39.7)	0.59
AH-24A-A7 <i>Seven pass</i>	10 (5.6)	—	—	—	—	—	—	—	—	—	—	—	—
	20 (11.1)	167.2	18.1	99.0 (37.2)	4.98	204.3	21.9	107.8 (42.1)	7.09	241.3	25.6	116.5 (46.9)	9.48
	40 (22.2)	118.1	6.41	87.3 (30.7)	0.69	163.6	8.80	98.0 (36.7)	1.25	201.6	10.7	107.0 (41.7)	1.80
AH-24B-A1* <i>One pass Tandem</i>	10 (5.6)	286.4	62.1	94.0 (34.4)	0.25	352.4	75.6	101.9 (38.8)	0.36	418.1	88.6	43.3 (109.9)	0.48
	20 (11.1)	173.8	18.8	80.5 (26.9)	0.03	260.1	27.9	90.8 (32.7)	0.06	335.6	35.6	37.7 (99.8)	0.09
	40 (22.2)	69.2	3.69	67.9 (19.9)	0.00	96.7	5.12	71.2 (21.8)	0.00	156.0	8.22	25.7 (78.2)	0.01
AH-24B-A3 <i>Three pass Tandem</i>	10 (5.6)	330.2	71.7	99.3 (37.4)	7.73	394.6	84.7	107.1 (41.7)	10.4	458.8	97.3	114.9 (46.1)	13.5
	20 (11.1)	290.2	31.6	94.5 (34.7)	1.67	355.7	38.3	102.3 (39.1)	2.35	420.8	44.7	110.2 (43.4)	3.12
	40 (22.2)	194.0	10.6	82.9 (28.3)	0.22	269.8	14.6	91.9 (33.3)	0.39	348.2	18.6	101.4 (38.6)	0.61
AH-24B-A5 <i>Five pass Tandem</i>	10 (5.6)	—	—	—	—	—	—	—	—	—	—	—	—
	20 (11.1)	308.7	33.6	96.7 (35.9)	8.14	373.4	40.2	104.5 (40.3)	11.12	437.9	46.6	112.3 (44.6)	14.7
	40 (22.2)	239.5	13.1	88.3 (31.3)	1.41	312.2	16.9	97.1 (36.2)	2.23	378.3	20.2	105.0 (40.6)	3.07
AH-24B-A7 <i>Seven pass Tandem</i>	10 (5.6)	—	—	—	—	—	—	—	—	—	—	—	—
	20 (11.1)	—	—	—	—	—	—	—	—	—	—	—	—
	40 (22.2)	261.0	14.3	90.9 (32.7)	4.35	326.9	17.7	98.9 (37.2)	6.37	392.4	21.0	106.7 (41.5)	8.65

* Single-pass heaters are not recommended for liquid service. In many cases, a smaller multi-pass model would be a more economical choice. For 50 Hz power supply, derate output by 10%. For complete model coding, refer to page 69. Above figures are based on calculations at sea level.

		ENTERING GLYCOL TEMPERATURE											
		180°F (82°C)				200°F (93°C)				220°F (104°C)			
MODEL	ΔT °F (C°)	OUTPUT MBH	FLOW USGPM	FAT °F (°C)	PD PSI	OUTPUT MBH	FLOW USGPM	FAT °F (°C)	PD PSI	OUTPUT MBH	FLOW USGPM	FAT °F (°C)	PD PSI
AH-12A-B1* <i>One pass</i>	10 (5.6)	9.1	1.83	66.6 (19.2)	0.00	11.2	2.22	68.0 (20.0)	0.00	13.3	2.61	69.6 (21.1)	0.00
	20 (11.1)	6.6	0.64	64.6 (18.1)	0.00	8.2	0.78	65.6 (18.7)	0.00	9.7	0.93	66.8 (19.3)	0.00
	40 (22.2)	4.4	0.21	62.9 (17.2)	0.00	5.6	0.26	63.7 (17.6)	0.00	6.8	0.31	64.5 (18.1)	0.00
AH-12A-B3 <i>Three pass</i>	10 (5.6)	26.7	5.68	80.4 (26.9)	0.05	42.0	8.88	92.4 (33.6)	0.11	53.1	11.1	101.2 (38.4)	0.17
	20 (11.1)	10.1	1.03	67.3 (19.6)	0.00	12.5	1.25	69.1 (20.6)	0.00	14.6	1.47	70.6 (21.4)	0.00
	40 (22.2)	6.8	0.34	64.8 (18.2)	0.00	8.6	0.42	66.0 (18.9)	0.00	10.5	0.51	67.4 (19.7)	0.00
AH-16A-B1* <i>One pass</i>	10 (5.6)	17.4	3.61	68.4 (20.2)	0.00	21.4	4.37	70.3 (21.3)	0.00	25.4	5.13	72.3 (22.4)	0.00
	20 (11.1)	12.6	1.27	65.9 (18.8)	0.00	15.5	1.56	67.3 (19.6)	0.00	18.6	1.84	68.8 (20.4)	0.00
	40 (22.2)	8.4	0.41	63.8 (17.7)	0.00	10.6	0.51	64.8 (18.2)	0.00	12.9	0.62	65.9 (18.8)	0.00
AH-16A-B3 <i>Three pass</i>	10 (5.6)	57.2	12.3	88.9 (31.6)	0.13	78.6	16.8	99.9 (37.7)	0.23	96.7	20.4	109.2 (42.9)	0.34
	20 (11.1)	19.2	2.01	69.3 (20.7)	0.00	32.9	3.44	76.2 (24.6)	0.01	59.6	6.24	89.9 (32.2)	0.03
	40 (22.2)	13.0	0.66	66.1 (18.9)	0.00	16.4	0.83	67.8 (19.9)	0.00	20.0	1.00	69.5 (20.8)	0.00
AH-16A-B5 <i>Five pass</i>	10 (5.6)	72.5	15.7	96.8 (36.0)	0.91	90.3	19.3	106.0 (41.1)	1.37	108.1	22.8	115.2 (46.2)	1.91
	20 (11.1)	44.1	4.73	82.1 (27.8)	0.09	68.6	7.31	94.7 (24.8)	0.21	86.9	9.16	104.1 (40.1)	0.32
	40 (22.2)	15.8	0.82	67.6 (19.8)	0.00	20.0	1.03	69.6 (20.9)	0.00	24.3	1.24	71.7 (22.1)	0.01
AH-20A-B1* <i>One pass</i>	10 (5.6)	29.2	6.14	69.4 (20.8)	0.00	36.1	7.43	71.5 (21.9)	0.00	43.0	10.0	73.3 (23.2)	0.00
	20 (11.1)	21.0	2.18	66.7 (19.3)	0.00	26.3	2.66	68.2 (20.1)	0.00	31.1	3.15	69.9 (21.1)	0.00
	40 (22.2)	14.0	0.71	64.3 (17.9)	0.00	18.0	0.88	65.4 (18.6)	0.00	21.5	1.06	66.6 (19.2)	0.00
AH-20A-B3 <i>Three pass</i>	10 (5.6)	102.9	22.2	94.3 (34.6)	0.28	130.8	28.0	103.8 (39.9)	0.43	158.6	33.5	113.2 (45.1)	0.62
	20 (11.1)	32.1	3.37	70.4 (21.3)	0.01	79.3	8.45	86.3 (30.2)	0.04	119.2	12.6	99.7 (37.6)	0.09
	40 (22.2)	21.7	1.13	66.9 (19.4)	0.00	27.5	1.42	68.7 (20.4)	0.00	33.4	1.71	70.6 (21.4)	0.00
AH-20A-B5 <i>Five pass</i>	10 (5.6)	118.6	25.7	99.7 (37.6)	1.65	146.0	31.3	109.0 (42.8)	2.43	173.3	36.7	118.3 (47.9)	3.32
	20 (11.1)	83.0	8.98	87.6 (30.9)	0.22	116.5	12.5	98.9 (37.2)	0.41	144.6	15.3	108.4 (42.4)	0.60
	40 (22.2)	26.4	1.39	68.5 (20.3)	0.01	33.4	1.74	70.7 (21.5)	0.01	78.1	4.12	85.7 (29.8)	0.05
AH-24A-B1* <i>One pass</i>	10 (5.6)	43.6	9.14	70.4 (21.3)	0.00	79.4	16.7	79.3 (26.3)	0.01	127.2	26.6	91.8 (33.2)	0.01
	20 (11.1)	31.9	3.29	67.5 (19.7)	0.00	39.4	4.02	69.2 (20.7)	0.00	47.2	4.76	71.1 (21.7)	0.00
	40 (22.2)	21.4	1.08	64.9 (18.3)	0.00	27.1	1.35	66.2 (19.0)	0.00	32.9	1.63	67.5 (19.7)	0.00
AH-24A-B3 <i>Three pass</i>	10 (5.6)	136.2	29.4	93.7 (34.3)	0.35	170.4	36.4	102.3 (39.1)	0.53	204.5	43.1	110.8 (43.8)	0.74
	20 (11.1)	74.3	7.94	78.1 (25.6)	0.03	117.7	12.5	88.9 (31.6)	0.07	162.3	17.1	100.1 (37.8)	0.12
	40 (22.2)	32.7	1.70	67.7 (19.8)	0.00	41.3	2.13	69.7 (20.9)	0.00	50.2	2.56	71.8 (22.1)	0.00
AH-24A-B5 <i>Five pass</i>	10 (5.6)	152.5	33.0	97.8 (36.6)	1.99	186.1	39.8	106.3 (41.3)	2.86	219.7	46.4	114.7 (45.9)	3.86
	20 (11.1)	119.9	13.0	89.6 (32.0)	0.33	154.3	16.5	98.2 (36.8)	0.52	188.7	19.9	106.8 (41.6)	0.75
	40 (22.2)	39.2	2.06	69.3 (20.7)	0.01	73.8	3.90	77.9 (25.5)	0.03	119.7	6.31	89.3 (31.8)	0.08
AH-24A-B7 <i>Seven pass</i>	10 (5.6)	160.2	34.6	99.8 (37.7)	5.90	193.5	41.4	108.1 (42.3)	8.34	226.9	47.9	116.5 (46.9)	11.2
	20 (11.1)	133.1	14.4	92.9 (38.3)	1.07	167.2	17.9	101.4 (38.6)	1.63	201.2	21.3	110.0 (43.3)	2.28
	40 (22.2)	65.9	3.53	76.0 (24.4)	0.07	109.4	5.84	86.8 (30.4)	0.19	153.1	8.11	97.8 (36.6)	0.35
AH-24B-B1* <i>One pass Tandem</i>	10 (5.6)	202.8	43.9	84.7 (29.3)	0.04	277.9	59.5	93.9 (34.4)	0.07	339.4	71.8	101.5 (38.6)	0.10
	20 (11.1)	81.3	8.66	69.7 (20.9)	0.00	117.0	12.4	73.3 (23.5)	0.00	149.9	22.7	86.0 (30.0)	0.01
	40 (22.2)	44.1	2.30	65.1 (18.4)	0.00	65.6	3.42	66.7 (19.7)	0.00	85.3	4.41	70.0 (21.1)	0.00
AH-24B-B3 <i>Three pass Tandem</i>	10 (5.6)	282.8	61.4	94.6 (34.8)	1.81	342.5	73.4	102.0 (38.9)	2.53	402.1	85.2	109.4 (43.0)	3.36
	20 (11.1)	231.7	25.2	88.3 (31.3)	0.33	292.7	31.4	95.8 (35.4)	0.50	353.6	37.5	103.3 (39.6)	0.70
	40 (22.2)	81.9	4.39	69.7 (20.9)	0.01	176.6	9.47	81.4 (27.4)	0.05	249.3	13.3	90.3 (32.4)	0.10
AH-24B-B5 <i>Five pass Tandem</i>	10 (5.6)	298.9	64.9	96.6 (35.9)	8.94	358.1	76.8	104.0 (40.0)	12.3	—	—	—	—
	20 (11.1)	259.7	28.2	91.7 (33.2)	1.82	319.9	34.3	99.2 (37.3)	2.63	379.9	40.3	106.6 (41.4)	3.55
	40 (22.2)	173.1	9.42	81.0 (27.2)	0.23	247.4	13.3	90.1 (32.3)	0.44	309.1	16.5	97.8 (36.6)	0.64
AH-24B-B7 <i>Seven pass Tandem</i>	10 (5.6)	—	—	—	—	—	—	—	—	—	—	—	—
	20 (11.1)	273.0	29.7	93.4 (34.1)	5.33	332.7	35.8	100.8 (38.2)	7.56	392.2	41.7	108.2 (42.3)	10.1
	40 (22.2)	208.3	11.4	85.4 (29.7)	0.86	269.7	14.6	92.9 (33.8)	1.36	330.7	17.6	100.5 (38.1)	1.95

* Single-pass heaters are not recommended for liquid service. In many cases, a smaller multi-pass model would be a more economical choice. For 50 Hz power supply, derate output by 10%. For complete model coding, refer to page 69. Above figures are based on calculations at sea level.

		ENTERING WATER TEMPERATURE											
		180°F (82°C)				200°F (93°C)				220°F (104°C)			
MODEL	ΔT °F (°C)	OUTPUT MBH	FLOW USGPM	FAT °F (°C)	PD PSI	OUTPUT MBH	FLOW USGPM	FAT °F (°C)	PD PSI	OUTPUT MBH	FLOW USGPM	FAT °F (°C)	PD PSI
AH-12A-A1* <i>One pass</i>	10 (5.6)	37.6	7.29	89.4 (31.9)	0.01	50.4	9.75	99.5 (37.5)	0.01	64.3	12.4	110.6 (43.7)	0.02
	20 (11.1)	18.9	1.79	74.4 (23.6)	0.00	23.6	2.23	78.0 (25.6)	0.00	37.2	3.55	88.7 (31.5)	0.00
	40 (22.2)	13.2	0.61	69.8 (21.0)	0.00	16.9	0.79	72.7 (22.6)	0.00	20.9	0.97	75.7 (24.3)	0.00
AH-12A-A3 <i>Three pass</i>	10 (5.6)	53.7	10.5	102.3 (39.1)	0.35	64.9	12.6	111.3 (44.1)	0.51	76.1	14.7	120.3 (49.1)	0.69
	20 (11.1)	42.5	4.13	93.3 (34.1)	0.06	55.6	5.39	103.7 (39.8)	0.10	67.0	6.48	112.8 (44.9)	0.14
	40 (22.2)	18.6	0.88	74.2 (23.4)	0.00	31.7	1.52	84.4 (29.1)	0.01	46.0	2.21	95.8 (35.4)	0.02
AH-16A-A1* <i>One pass</i>	10 (5.6)	72.3	14.1	95.5 (35.3)	0.02	94.2	18.3	106.5 (41.4)	0.03	113.0	21.9	115.9 (46.6)	0.04
	20 (11.1)	34.2	3.28	76.4 (24.7)	0.00	58.2	5.62	88.3 (31.3)	0.00	81.7	7.89	100.0 (37.8)	0.01
	40 (22.2)	24.0	1.14	71.4 (21.9)	0.00	30.8	1.46	74.7 (23.7)	0.00	38.0	1.80	78.1 (25.6)	0.00
AH-16A-A3 <i>Three pass</i>	10 (5.6)	91.7	17.9	105.3 (40.7)	0.69	110.1	21.4	114.5 (45.8)	0.98	128.5	25.0	123.8 (51.0)	1.32
	20 (11.1)	78.2	7.63	98.5 (36.9)	0.13	96.9	9.43	107.8 (42.1)	0.20	115.6	11.2	117.2 (47.3)	0.28
	40 (22.2)	44.0	2.13	81.3 (27.4)	0.01	67.0	3.25	92.7 (33.7)	0.03	87.9	4.26	103.2 (39.6)	0.04
AH-16A-A5 <i>Five pass</i>	10 (5.6)	95.6	18.7	107.3 (41.8)	3.37	113.9	22.2	116.5 (26.9)	4.73	132.2	25.7	125.7 (52.1)	6.30
	20 (11.1)	85.1	8.31	102.0 (38.9)	0.70	103.6	10.1	111.2 (44.0)	1.02	122.1	11.9	120.5 (49.2)	1.39
	40 (22.2)	62.2	3.03	90.4 (32.4)	0.10	83.8	4.08	101.2 (38.4)	0.18	102.7	4.98	110.7 (43.7)	0.26
AH-20A-A1* <i>One pass</i>	10 (5.6)	117.1	22.9	96.3 (35.7)	0.03	144.4	28.1	104.9 (40.5)	0.04	171.6	33.4	113.5 (45.3)	0.06
	20 (11.1)	68.1	6.61	72.2 (22.3)	0.00	103.4	10.0	91.9 (33.3)	0.01	134.6	13.1	101.7 (38.7)	0.01
	40 (22.2)	40.3	1.93	72.2 (22.3)	0.00	51.4	2.47	75.6 (24.2)	0.00	63.2	3.02	79.2 (26.2)	0.00
AH-20A-A3 <i>Three pass</i>	10 (5.6)	136.7	26.7	102.5 (39.2)	0.95	163.4	31.9	111.0 (43.9)	1.34	190.2	37.0	119.5 (48.6)	1.79
	20 (11.1)	119.3	11.7	97.0 (36.1)	0.19	146.4	14.3	105.6 (40.9)	0.28	173.5	16.9	114.1 (45.6)	0.39
	40 (22.2)	78.4	3.82	84.1 (28.9)	0.02	109.2	5.31	93.7 (34.3)	0.04	142.0	6.90	104.1 (40.1)	0.07
AH-20A-A5 <i>Five pass</i>	10 (5.6)	141.4	27.7	104.0 (40.0)	4.58	168.0	32.8	112.5 (44.7)	6.37	194.6	37.9	120.9 (49.4)	8.45
	20 (11.1)	127.6	12.5	99.6 (37.6)	0.98	154.4	15.1	111.2 (42.3)	1.41	181.3	17.6	116.6 (47.0)	1.91
	40 (22.2)	100.7	4.92	91.2 (32.9)	0.17	128.2	6.25	99.8 (37.7)	0.26	155.6	7.57	108.4 (42.4)	0.37
AH-24A-A1* <i>One pass</i>	10 (5.6)	165.9	32.4	98.7 (37.1)	0.04	202.9	39.5	107.4 (41.9)	0.07	239.9	46.6	116.2 (46.8)	0.09
	20 (11.1)	113.2	11.0	86.2 (30.1)	0.01	156.3	15.2	96.3 (35.7)	0.01	196.9	19.1	105.9 (41.1)	0.02
	40 (22.2)	59.0	2.82	73.4 (23.0)	0.00	75.2	3.59	77.1 (25.1)	0.00	92.2	4.40	81.0 (27.2)	0.00
AH-24A-A3 <i>Three pass</i>	10 (5.6)	188.8	36.9	104.2 (40.1)	1.42	225.2	43.9	112.8 (44.9)	1.98	261.6	50.8	121.4 (49.7)	2.63
	20 (11.1)	167.3	16.3	99.0 (37.2)	0.30	204.1	19.9	107.7 (42.1)	0.43	240.9	23.4	118.6 (48.1)	0.59
	40 (22.2)	118.7	5.77	87.4 (30.8)	0.04	159.0	7.73	96.9 (36.1)	0.07	201.3	9.77	104.6 (40.9)	0.11
AH-24A-A5 <i>Five pass</i>	10 (5.6)	194.4	38.0	105.5 (40.8)	6.73	230.6	44.9	114.1 (45.6)	9.32	266.7	51.8	122.7 (50.4)	12.3
	20 (11.1)	176.9	17.3	101.3 (38.5)	1.47	213.4	20.8	110.0 (43.3)	2.09	249.9	24.3	118.6 (48.1)	2.82
	40 (22.2)	142.8	6.97	93.2 (34.0)	0.26	180.0	8.76	102.0 (38.9)	0.40	217.2	10.6	110.8 (43.8)	0.57
AH-24A-A7 <i>Seven pass</i>	10 (5.6)	—	—	—	—	—	—	—	—	—	—	—	—
	20 (11.1)	181.5	17.7	102.4 (39.1)	4.13	217.8	21.2	111.0 (43.9)	5.85	254.2	24.7	119.7 (48.7)	7.85
	40 (22.2)	150.6	7.35	95.0 (35.0)	0.77	187.7	9.14	103.8 (39.9)	1.16	224.7	10.91	112.6 (44.8)	1.62
AH-24B-A1* <i>One pass Tandem</i>	10 (5.6)	323.2	63.3	98.5 (36.9)	0.22	387.5	75.7	106.2 (41.2)	0.30	451.7	88.0	114.0 (45.6)	0.40
	20 (11.1)	278.4	27.3	93.0 (33.9)	0.05	343.6	33.6	100.9 (32.3)	0.07	408.7	39.8	108.7 (42.6)	0.09
	40 (22.2)	155.7	7.58	78.3 (25.7)	0.00	239.4	11.7	88.3 (31.3)	0.01	313.4	15.2	97.1 (36.2)	0.02
AH-24B-A3 <i>Three pass Tandem</i>	10 (5.6)	345.6	67.8	101.2 (38.4)	5.92	409.2	80.0	108.9 (42.7)	8.09	472.7	92.2	116.6 (47.0)	10.6
	20 (11.1)	317.3	31.1	97.8 (36.6)	1.35	381.4	37.3	105.5 (40.8)	1.89	445.4	43.4	113.2 (45.1)	2.51
	40 (22.2)	261.4	12.8	91.0 (32.8)	0.26	326.7	16.0	98.8 (37.1)	0.39	391.8	19.1	106.0 (41.5)	0.54
AH-24B-A5 <i>Five pass Tandem</i>	10 (5.6)	—	—	—	—	—	—	—	—	—	—	—	—
	20 (11.1)	326.7	32.0	98.9 (37.2)	6.26	390.5	38.2	106.6 (41.4)	8.72	454.2	44.3	114.3 (45.7)	11.5
	40 (22.2)	277.8	13.6	93.0 (33.9)	1.26	342.7	16.8	100.8 (38.2)	1.83	407.3	19.9	108.0 (42.6)	2.50
AH-24B-A7 <i>Seven pass Tandem</i>	10 (5.6)	—	—	—	—	—	—	—	—	—	—	—	—
	20 (11.1)	—	—	—	—	—	—	—	—	—	—	—	—
	40 (22.2)	285.5	14.0	93.9 (34.4)	3.48	350.2	17.1	101.7 (38.7)	5.03	414.6	20.2	109.5 (43.1)	6.88

* Single-pass heaters are not recommended for liquid service. In many cases, a smaller multi-pass model would be a more economical choice. For 50 Hz power supply, derate output by 10%. For complete model coding, refer to page 69. Above figures are based on calculations at sea level.

		ENTERING GLYCOL TEMPERATURE											
		180°F (82°C)				200°F (93°C)				220°F (104°C)			
MODEL	ΔT °F (°C)	OUTPUT MBH	FLOW USGPM	FAT °F (°C)	PD PSI	OUTPUT MBH	FLOW USGPM	FAT °F (°C)	PD PSI	OUTPUT MBH	FLOW USGPM	FAT °F (°C)	PD PSI
AH-12A-B1* <i>One pass</i>	10 (5.6)	9.1	1.83	66.6 (19.2)	0.00	11.2	2.22	68.0 (20.0)	0.00	13.3	2.61	69.6 (21.1)	0.00
	20 (11.1)	6.6	0.64	64.6 (18.1)	0.00	8.2	0.78	65.6 (18.7)	0.00	9.7	0.93	66.8 (19.3)	0.00
	40 (22.2)	4.4	0.21	62.9 (17.2)	0.00	5.6	0.26	63.7 (17.6)	0.00	6.8	0.31	64.5 (18.1)	0.00
AH-12A-B3 <i>Three pass</i>	10 (5.6)	26.7	5.68	80.4 (26.9)	0.05	42.0	8.88	92.4 (33.6)	0.11	53.1	11.1	101.2 (38.4)	0.17
	20 (11.1)	10.1	1.03	67.3 (19.6)	0.00	12.5	1.25	69.1 (20.6)	0.00	14.6	1.47	70.6 (21.4)	0.00
	40 (22.2)	6.8	0.34	64.8 (18.2)	0.00	8.6	0.42	66.0 (18.9)	0.00	10.5	0.51	67.4 (19.7)	0.00
AH-16A-B1* <i>One pass</i>	10 (5.6)	17.4	3.61	68.4 (20.2)	0.00	21.4	4.37	70.3 (21.3)	0.00	25.4	5.13	72.3 (22.4)	0.00
	20 (11.1)	12.6	1.27	65.9 (18.8)	0.00	15.5	1.56	67.3 (19.6)	0.00	18.6	1.84	68.8 (20.4)	0.00
	40 (22.2)	8.4	0.41	63.8 (17.7)	0.00	10.6	0.51	64.8 (18.2)	0.00	12.9	0.62	65.9 (18.8)	0.00
AH-16A-B3 <i>Three pass</i>	10 (5.6)	57.2	12.3	88.9 (31.6)	0.13	78.6	16.8	99.9 (37.7)	0.23	96.7	20.4	109.2 (42.9)	0.34
	20 (11.1)	19.2	2.01	69.3 (20.7)	0.00	32.9	3.44	76.2 (24.6)	0.01	59.6	6.24	89.9 (32.2)	0.03
	40 (22.2)	13.0	0.66	66.1 (18.9)	0.00	16.4	0.83	67.8 (19.9)	0.00	20.0	1.00	69.5 (20.8)	0.00
AH-16A-B5 <i>Five pass</i>	10 (5.6)	72.5	15.7	96.8 (36.0)	0.91	90.3	19.3	106.0 (41.1)	1.37	108.1	22.8	115.2 (46.2)	1.91
	20 (11.1)	44.1	4.73	82.1 (27.8)	0.09	68.6	7.31	94.7 (24.8)	0.21	86.9	9.16	104.1 (40.1)	0.32
	40 (22.2)	15.8	0.82	67.6 (19.8)	0.00	20.0	1.03	69.6 (20.9)	0.00	24.3	1.24	71.7 (22.1)	0.01
AH-20A-B1* <i>One pass</i>	10 (5.6)	29.2	6.14	69.4 (20.8)	0.00	36.1	7.43	71.5 (21.9)	0.00	40.3	16.8	86.5 (30.3)	0.01
	20 (11.1)	21.0	2.18	66.7 (19.3)	0.00	26.3	2.66	68.2 (20.1)	0.00	31.1	3.15	69.9 (21.1)	0.00
	40 (22.2)	14.0	0.71	64.3 (17.9)	0.00	18.0	0.88	65.4 (18.6)	0.00	21.5	1.06	66.6 (19.2)	0.00
AH-20A-B3 <i>Three pass</i>	10 (5.6)	102.9	22.2	94.3 (34.6)	0.28	130.8	28.0	103.8 (39.9)	0.43	158.6	33.5	113.2 (45.1)	0.62
	20 (11.1)	32.1	3.37	70.4 (21.3)	0.01	79.3	8.45	86.3 (30.2)	0.04	119.2	12.6	99.7 (37.6)	0.09
	40 (22.2)	21.7	1.13	66.9 (19.4)	0.00	27.5	1.42	68.7 (20.4)	0.00	33.4	1.71	70.6 (21.4)	0.00
AH-20A-B5 <i>Five pass</i>	10 (5.6)	118.6	25.7	99.7 (37.6)	1.65	146.0	31.3	109.0 (42.8)	2.43	173.3	36.7	118.3 (47.9)	3.32
	20 (11.1)	83.0	8.98	87.6 (30.9)	0.22	116.5	12.5	98.9 (37.2)	0.41	144.6	15.3	108.4 (42.4)	0.60
	40 (22.2)	26.4	1.39	68.5 (20.3)	0.01	33.4	1.74	70.7 (21.5)	0.01	78.1	4.12	85.7 (29.8)	0.05
AH-24A-B1* <i>One pass</i>	10 (5.6)	43.6	9.14	70.4 (21.3)	0.00	79.4	16.7	79.3 (26.3)	0.01	127.2	26.6	91.8 (33.2)	0.01
	20 (11.1)	31.9	3.29	67.5 (19.7)	0.00	39.4	4.02	69.2 (20.7)	0.00	47.2	4.76	71.1 (21.7)	0.00
	40 (22.2)	21.4	1.08	64.9 (18.3)	0.00	27.1	1.35	66.2 (19.0)	0.00	32.9	1.63	67.5 (19.7)	0.00
AH-24A-B3 <i>Three pass</i>	10 (5.6)	136.2	29.4	93.7 (34.3)	0.35	170.4	36.4	102.3 (39.1)	0.53	204.5	43.1	110.8 (43.8)	0.74
	20 (11.1)	74.3	7.94	78.1 (25.6)	0.03	117.7	12.5	88.9 (31.6)	0.07	162.3	17.1	100.1 (37.8)	0.12
	40 (22.2)	32.7	1.70	67.7 (19.8)	0.00	41.3	2.13	69.7 (20.9)	0.00	50.2	2.56	71.8 (22.1)	0.00
AH-24A-B5 <i>Five pass</i>	10 (5.6)	152.5	33.0	97.8 (36.6)	1.99	186.1	39.8	106.3 (41.3)	2.86	219.7	46.4	114.7 (45.9)	3.86
	20 (11.1)	119.9	13.0	89.6 (32.0)	0.33	154.3	16.5	98.2 (36.8)	0.52	188.7	19.9	108.4 (41.6)	0.75
	40 (22.2)	39.2	2.06	69.3 (20.7)	0.01	73.8	3.90	77.9 (25.5)	0.03	119.7	6.31	89.3 (31.8)	0.08
AH-24A-B7 <i>Seven pass</i>	10 (5.6)	160.2	34.6	99.8 (37.7)	5.90	193.5	41.4	108.1 (42.3)	8.34	226.9	47.9	116.5 (46.9)	11.2
	20 (11.1)	133.1	14.4	92.9 (38.3)	1.07	167.2	17.9	101.4 (38.6)	1.63	201.2	21.3	110.0 (43.3)	2.28
	40 (22.2)	65.9	3.53	76.0 (24.4)	0.07	109.4	5.84	86.8 (30.4)	0.19	153.1	8.11	97.8 (36.6)	0.35
AH-24B-B1* <i>One pass Tandem</i>	10 (5.6)	202.8	43.9	84.7 (29.3)	0.04	277.9	59.5	93.9 (34.4)	0.07	339.4	71.8	101.5 (38.6)	0.10
	20 (11.1)	81.3	8.66	69.7 (20.9)	0.00	117.0	12.4	23.3 (74.0)	0.00	214.9	22.7	86.0 (30.0)	0.01
	40 (22.2)	44.1	2.30	65.1 (18.4)	0.00	65.6	3.42	67.7 (19.8)	0.00	85.3	4.41	70.0 (21.1)	0.00
AH-24B-B3 <i>Three pass Tandem</i>	10 (5.6)	282.8	61.4	94.6 (34.8)	1.81	342.5	73.4	102.0 (38.9)	2.53	402.1	85.2	109.4 (43.0)	3.36
	20 (11.1)	231.7	25.2	88.3 (31.3)	0.33	292.7	31.4	95.8 (35.4)	0.50	353.6	37.5	103.3 (39.6)	0.70
	40 (22.2)	81.9	4.39	69.7 (20.9)	0.01	176.6	9.47	81.4 (27.4)	0.05	249.3	13.3	90.3 (32.4)	0.10
AH-24B-B5 <i>Five pass Tandem</i>	10 (5.6)	298.9	64.9	96.6 (35.9)	8.94	358.1	76.8	104.0 (40.0)	12.3	—	—	—	—
	20 (11.1)	259.7	28.2	91.7 (33.2)	1.82	319.9	34.3	99.2 (37.3)	2.63	379.9	40.3	106.6 (41.4)	3.55
	40 (22.2)	173.1	9.42	81.0 (27.2)	0.23	247.4	13.3	90.1 (32.3)	0.44	309.1	16.5	97.8 (36.6)	0.64
AH-24B-B7 <i>Seven pass Tandem</i>	10 (5.6)	—	—	—	—	—	—	—	—	—	—	—	—
	20 (11.1)	273.0	29.7	93.4 (34.1)	5.33	332.7	35.8	100.8 (38.2)	7.56	392.2	41.7	108.2 (42.3)	10.1
	40 (22.2)	208.3	11.4	85.4 (29.7)	0.86	269.7	14.6	92.9 (33.8)	1.36	330.7	17.6	100.5 (38.1)	1.95

* Single-pass heaters are not recommended for liquid service. In many cases, a smaller multi-pass model would be a more economical choice. For 50 Hz power supply, derate output by 10%. For complete model coding, refer to page 69. Above figures are based on calculations at sea level.

Explosion-Proof Exhaust Fan

The EFX Explosion-Proof Exhaust Fan is designed for hazardous and general purpose industrial applications. The EFX is constructed with epoxy-coated steel panels and spark resistant aluminum fan blades for ventilation of combustible materials, vapors and hazardous fumes. The EFX is fully assembled for easy installation, has explosion-proof motors that are CSA approved and/or UL listed with fan guards conforming to OSHA specifications.



EFX General Specifications

Approvals	Motors are CSA approved and/or UL listed
Hazardous Locations Classifications	Class I, Div. 1 & 2, Groups C, D Class II, Div. 1 & 2, Groups E, F, G Temperature Code: T3B 329°F (165°C)
Motors	CSA approved and/or UL listed permanently lubricated ball bearing type with rigid base. Explosion-proof or totally enclosed construction All standard voltages for 60 and 50 hertz are available
Fan	Aluminum blade. Steel spider and hub with 5/8" (15.875 mm) bore Optional Heresite® coating for corrosive atmospheres
Fan Guard	Split design with close wire spacing, meets OSHA requirements
Mounting	Four 3/8" (9.5 mm) diameter holes Must be mounted to a rigid structure
Frame Material	16-gauge (0.060" / 1.52 mm) epoxy-coated steel Optional stainless-steel or Heresite® coating for corrosive atmospheres

Model	EFX12	EFX16	EFX20	EFX24	EFX30	
Fan Diameter	12" (305 mm)	16" (406 mm)	20" (508 mm)	24" (610 mm)	30" (762 mm)	
Motor*	1/2 HP, 60Hz (0.373 kW)	1/2 HP, 60Hz (0.373 kW)	1/2 HP, 60Hz (0.373 kW)	1/2 HP, 60Hz (0.373 kW)	3/4 HP, 60Hz (0.560 kW)	
Motor Speed	1725 RPM	1725 RPM	1725 RPM	1725 RPM	1140 RPM	
Sound Level (dBA)	77.6	82.5	83.7	84.6	87.5	
Net Weight	51.0 lbs (23.1 kg)	55.0 lbs (24.9 kg)	59.0 lbs (26.7 kg)	61.0 lbs (27.7 kg)	67.0 lbs (30.4 kg)	
Shipping Weight	56.0 lbs (25.4 kg)	61.0 lbs (27.7 kg)	67.0 lbs (30.3 kg)	96.0 lbs (43.5 kg)	114.0 lbs (51.7 kg)	
Dimensions	Width	16.1"	20.2"	24.2"	28.1"	34.0"
		(410 mm)	(513 mm)	(615 mm)	(715 mm)	(863 mm)
	Height	18.2"	23.1"	27.1"	31.0"	37.1"
		(462 mm)	(588 mm)	(688 mm)	(788 mm)	(942 mm)
Depth	15.4"	14.9"	16.1"	15.5"	15.6"	
	(392 mm)	(378 mm)	(410 mm)	(394 mm)	(397 mm)	

Note:
50Hz units also available.

EFX

Model Coding

EFX 12 A 1 A

EXHAUST FAN MODEL	
EFX	EXHAUST FAN

FAN SIZE	
12" (305 mm) DIA	12
16" (406 mm) DIA	16
20" (508 mm) DIA	20
24" (610 mm) DIA	24
30" (762 mm) DIA	30

CABINET MATERIAL	
EPOXY POWDER COATED CARBON STEEL	A
HERESITE® PHENOLIC COATED CARBON STEEL	B
Stainless-steel	C

MOTOR ELECTRICAL			
	VOLTS	PHASE	HERTZ
A	115	1	60
B	208	1	60
C	208	3	60
D	230	1	60
E	230	3	60
①② F	460	1	60
G	460	3	60
H	575	3	60
I	220	1	50
J	380	3	50
② K	440	3	50

MOTOR ENCLOSURE	
1	TOTALLY ENCLOSED
2	X-PROOF, GR C, D, E, F & G
② 3	WASHDOWN
② 4	WASHDOWN Stainless-steel
② 5	SPECIAL MOTOR

Note:

- ① Only available for Class 1 Group D, Class 2 Group F & G.
- ② Consult factory for motor availability.

Air Flow Rating

MODEL	AIR DELIVERY AT STATIC PRESSURE (INCHES-WATER GAGE)										
	0.00	0.05	0.10	0.15	0.20	0.25	0.288	0.35	0.40	0.50	
EFX12	CFM	1199	1155	1110	1057	990	849	779	710	677	618
	m ³ /hr	2037	1962	1886	1796	1682	1442	1324	1206	1150	1050
EFX16	CFM	2173	2103	2031	1949	1825	1690	1567	1469	1384	1263
	m ³ /hr	3692	3573	3451	3311	3101	2871	2662	2496	2351	2146
EFX20	CFM	3303	3238	3172	3115	3032	2944	2830	2696	2560	2280
	m ³ /hr	5612	5501	5389	5292	5151	5002	4808	4581	4349	3874
EFX24	CFM	3947	3858	3775	3691	3518	3475	3357	3232	3102	2821
	m ³ /hr	6706	6555	6413	6271	5977	5904	5704	5491	5270	4793
EFX30	CFM	6600	6416	6213	6037	5822	5551	5311	4993	4654	4070
	m ³ /hr	11213	10901	10556	10257	9892	9431	9023	8483	7907	6915

EFX

Performance Data for 60 Hertz Motor

60 Hertz EFX Explosion-Proof Exhaust Fan					
Class I, Div. 1 & 2, Groups C,D, Class II, Div. 1 & 2, Groups E,F,G					
Model	Fan Size	Voltage	Phase	Approximate Shipping Weight	
				lbs	kg
EFX-12A-2A	12	115	1	56	26
EFX-12A-2B	12	208	1	56	26
EFX-12A-2C	12	208	3	56	26
EFX-12A-2D	12	240	1	56	26
EFX-12A-2E	12	230	3	56	26
EFX-12A-2G	12	460	3	56	26
EFX-12A-2H	12	575	3	56	26
EFX-16A-2A	16	115	1	61	29
EFX-16A-2B	16	208	1	61	29
EFX-16A-2C	16	208	3	61	29
EFX-16A-2D	16	230	1	61	29
EFX-16A-2E	16	230	3	61	29
EFX-16A-2G	16	460	3	61	29
EFX-16A-2H	16	575	3	61	29
EFX-20A-2A	20	115	1	67	31
EFX-20A-2B	20	208	1	67	31
EFX-20A-2C	20	208	3	67	31
EFX-20A-2D	20	230	1	67	31
EFX-20A-2E	20	230	3	67	31
EFX-20A-2G	20	460	3	67	31
EFX-20A-2H	20	575	3	67	31
EFX-24A-2A	24	115	1	96	44
EFX-24A-2B	24	208	1	96	44
EFX-24A-2C	24	208	3	96	44
EFX-24A-2D	24	230	1	96	44
EFX-24A-2E	24	230	3	96	44
EFX-24A-2G	24	460	3	96	44
EFX-24A-2H	24	575	3	96	44
EFX-30A-2A	30	115	1	114	52
EFX-30A-2B	30	208	1	114	52
EFX-30A-2C	30	208	3	114	52
EFX-30A-2D	30	230	1	114	52
EFX-30A-2E	30	230	3	114	52
EFX-30A-2G	30	460	3	114	52
EFX-30A-2H	30	575	3	114	52

EFX

Performance Data for 50 Hertz Motor

50 Hertz EFX Explosion-Proof Exhaust Fan					
Class I, Div. 1 & 2, Groups C,D, Class II, Div. 1 & 2, Groups E,F,G					
Model	Fan Size	Voltage	Phase	Approximate Shipping Weight	
				lbs	kg
EFX-12A-2I	12	220	1	56	26
EFX-12A-2J	12	380	3	56	26
EFX-12A-2K	12	440	3	56	26
EFX-16A-2I	16	220	1	61	29
EFX-16A-2J	16	380	3	61	29
EFX-16A-2K	16	440	3	61	29
EFX-20A-2I	20	220	1	67	31
EFX-20A-2J	20	380	3	67	31
EFX-20A-2K	20	440	3	67	31
EFX-24A-2I	24	220	1	96	44
EFX-24A-2J	24	380	3	96	44
EFX-24A-2K	24	440	3	96	44
EFX-30A-2I	30	220	1	114	52
EFX-30A-2J	30	380	3	114	52
EFX-30A-2K	30	440	3	114	52

EFX Explosion-Proof Exhaust Fan Physical Dimensions

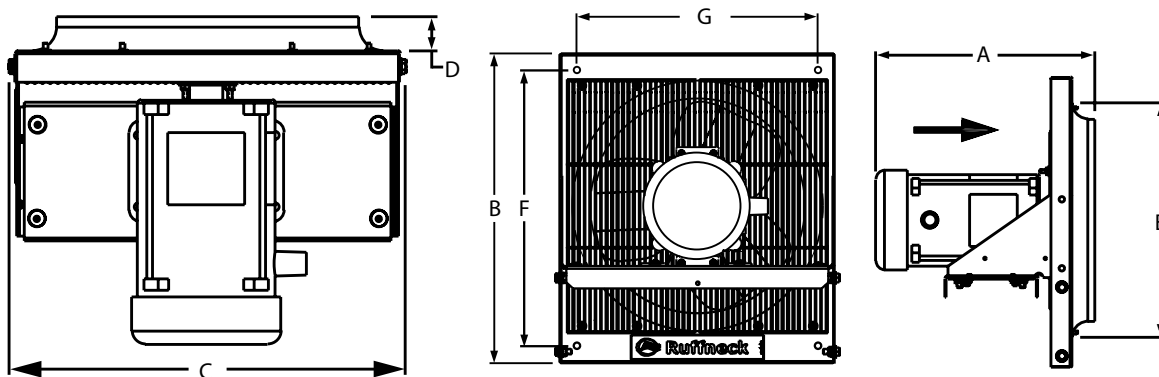

DIMENSION	EFX-12	EFX-16	EFX-20	EFX-24	EFX-30	
A	mm	392.1	377.8	409.6	393.7	396.9
	in	15.4	14.9	16.1	15.5	15.6
B	mm	461.9	588	687.9	787.9	942.3
	in	18.2	23.2	27.1	31	37.1
C	mm	410	512.5	614.5	714.5	862.5
	in	16.1	20.2	24.2	28.1	34
D	mm	79.4	57.2	91.7	76.2	88.9
	in	3.1	2.2	3.6	3	3.5
E	mm	373.3	475.6	577.3	677.3	835.3
	in	14.7	18.7	22.7	24.7	32.9
F	mm	411.1	537.2	637.1	737.1	891.5
	in	16.2	21.2	25.1	29	35.1
G	mm	359.2	461.7	563.7	663.7	811.7
	in	14.1	18.2	22.2	26.1	32

EFX

EFX Accessories

Stormhood

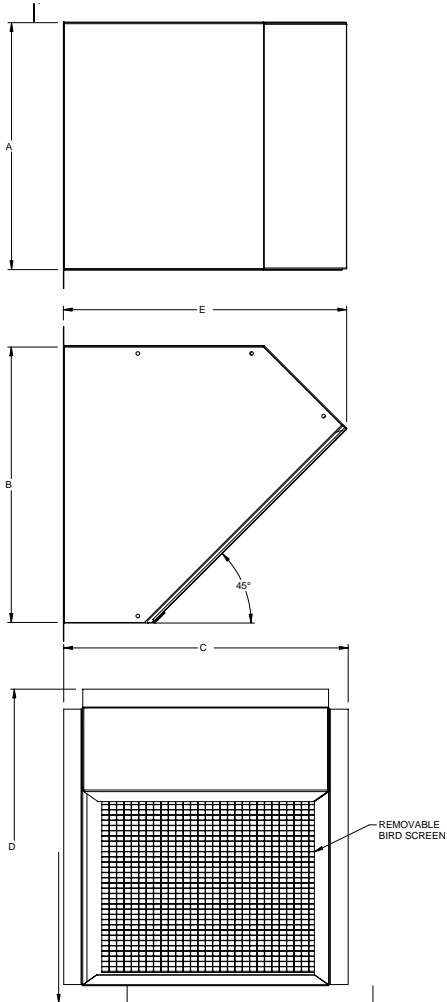
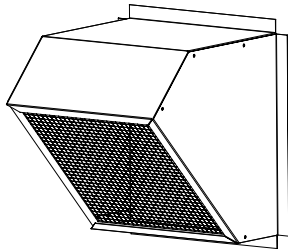

NOTES:
1) MATERIAL: 20 Ga GALVANIZED METAL

MODEL SIZE	OPENING				C		D		E		CCI PART NUMBER
	mm	Inches	mm	Inches	mm	Inches	mm	Inches	mm	Inches	
12	422.3	16 5/8	473.1	18 5/8	485.8	19 1/8	536.6	21 1/8	486.1	19 1/8	10210
16	523.9	20 5/8	600.1	23 5/8	587.4	23 1/8	663.6	26 1/8	616.5	24 1/4	10211
20	625.5	24 5/8	698.5	27 1/2	689	27 1/8	762	30	717.7	28 1/4	10212
24	727.1	28 5/8	800.1	31 1/2	790.6	31 1/8	863.6	34	822	32 3/8	10213
30	876.3	34 1/2	952.5	37 1/2	939.8	37	1016	40	978.7	38 1/2	10214

Backdraft Damper

MODEL SIZE	A		B		C		D		E	CCI PART NUMBER
	mm	Inches	mm	Inches	mm	Inches	mm	Inches	mm/Inches	
12	514.4	20 1/4	489.0	19 1/4	463.6	18 1/4	409.6	16 1/8	50.8 (2)	10205
16	666.8	26 1/4	590.6	23 1/4	573.6	22 9/16	511.2	20 1/8		10206
20	765.2	30 1/8	692.2	27 1/4	689.0	27 1/8	616.0	24 1/4		10207
24	866.8	34 1/8	793.8	31 1/4	787.4	31	717.6	28 1/4		10208
30	1019.2	40 1/8	939.8	37	943.0	37 1/8	863.6	34		10209

NOTES:
1) MATERIAL: ALUMINUM EXTRUSIONS.

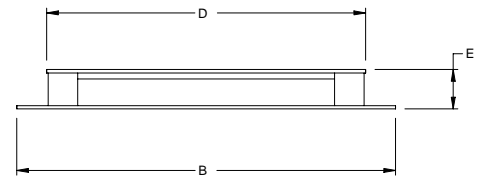
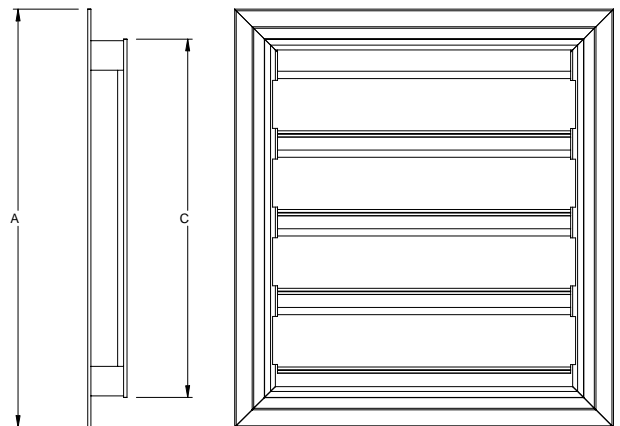
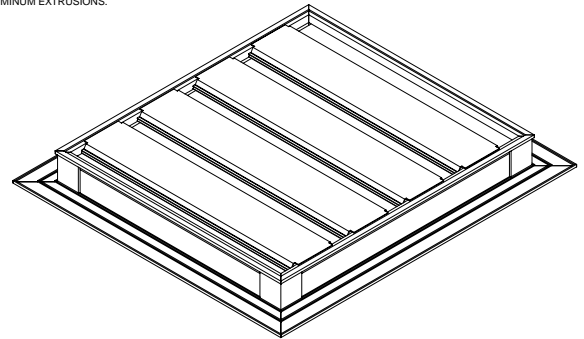

XS Disconnect Switch



Specifications

Temperature Range: -40°F to 104°F (-40°C to 40°C)

Net Weight: 12 lb (5.5 kg)

Switching: Disconnect

Conduit Opening: 2 x 1" NPT ports

Electrical Rating

Part No.	Volts	Phase	Hertz	Amps (A)
XS40	600	3	50/60	40
XS60	600	3	50/60	60

- Class I, Divisions 1 & 2, Groups A, B, C & D
- Class II, Divisions 1 & 2, Groups E, F & G
- Class III, Divisions 1 & 2

Approvals

- _cCSA_{US} Certified

The Ruffneck™ XS Disconnect Switch is engineered for use in the most demanding applications such as drilling rigs, utilidors and compression stations where high vibration, dirt, moisture, fluctuating power and high impact conditions exist. The XS Disconnect Switch is suitable for all Ruffneck™ heaters (FX, XL, AH, FR, HP) as well as main switches for equipment and machines.

It is designed for use in hazardous locations where specific explosive gases or dusts are present.

More Features ... More Benefits:

- anodize aluminum, copper free aluminum exterior
- corrosion-resistant, suitable for H₂S environments
- precision extruded aluminum components
- suitable for high vibration installations
- suitable for dirty environments
- impact resistant with no moving parts
- 600 VAC maximum
- comes pre-wired for easy installation
- compatible with all Ruffneck™ heaters (FX, XL, AH, FR, HP)
- suitable for single phase and three phase systems

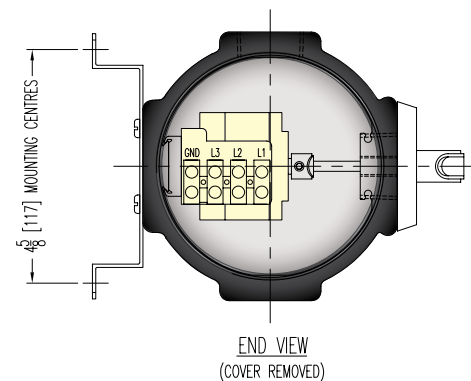
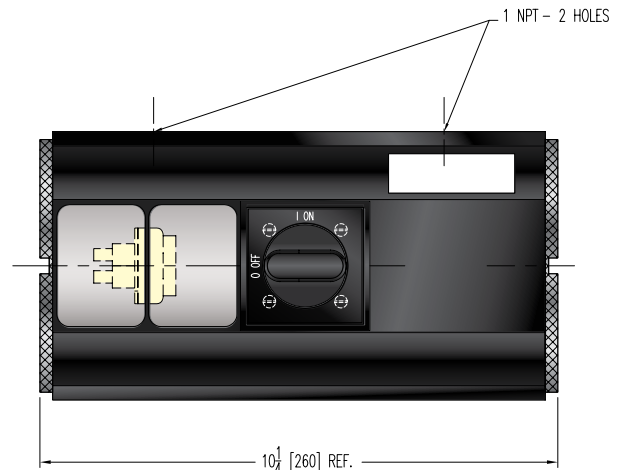

XS

Thermostats

Defender® Explosion-Proof Thermostats

XT-311 and XT-312 Defender® Thermostat

Ruffneck™ Defender® XT-311 and XT-312 explosion-proof heavy-duty thermostats are the smallest, lightest and most durable thermostats available. These thermostats are designed to control heating only, cooling only, or ventilation systems in demanding industrial applications. These include oil refineries, petrochemical plants, pulp and paper mills, coal mines, grain elevators, hazardous waste storage facilities, and other hazardous locations where specific explosive gases or dusts are present.



For hazardous-location temperature controls, rely on Defender® thermostats for the most dependable and trouble-free service available. Ruffneck™ Defender® XT-311 and XT-312 thermostat's unique and highly engineered design offers outstanding features and benefits.

More Features ... More Benefits:

- all-aluminum exterior
- no breakable external plastic parts
- no exposed copper or brass
- corrosion resistant, suitable for H₂S environments
- compact & lightweight
- more competitively priced
- CFC & mercury free
- environmentally safe, no leveling required
- 3-year warranty: longest trouble-free warranty in the industry
- precision die-cast components
- greater consistency, better quality
- bimetal sensing element
- fast-acting, reliable, unaffected by altitude
- no delicate coils or bellows
- rugged reliability
- 480 VAC maximum
- wider range of applications

Specifications

Temperature range: 36°F to 82°F (2°C to 28°C)
Temperature differential: 2.5 F° (1.5 C°)
Net weight: 2.1 lbs (0.95 kg)
Switching: Snap acting
Conduit opening: 3/4" - 14 NPT



Electrical Rating

22 amps Res., 480 VAC Max.;
1/2 HP @ 125 VAC, 1 HP @ 250 VAC

Class I, Divisions 1 & 2, Groups C & D;
Class II, Division 1, Groups E, F, & G;
Class II, Division 2, Groups F & G; Class III;
Class I, Zones 1 & 2, Groups IIA & IIB

Available in Two Models

XT-311 (Feed-Through, Single Pole, Single Throw)
For heating-only applications.

XT-312 (Feed-Through, Single Pole, Double Throw)
For heating or cooling / ventilation applications.

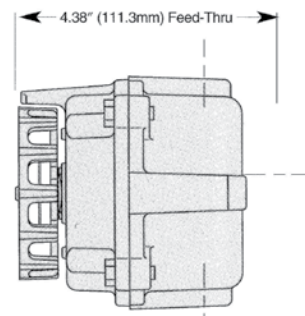
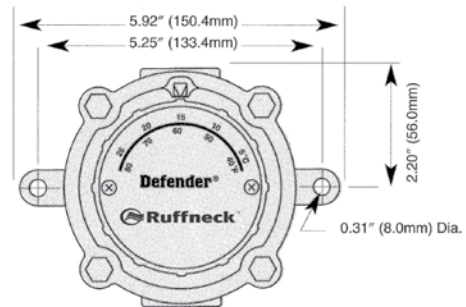

XT-311, XT-312 Defender®

Defender®
Explosion-Proof Thermostats



XT-411 Defender® Thermostat

Ruffneck™ Defender® XT-411 is engineered for use in the most demanding applications such as drilling rigs, utilidors and compression stations where dirt, fluctuating power and high impact conditions exist. It is considered the most robust and trouble-free thermostat in the market due to its solid construction.

The Ruffneck™ Defender® XT-411 thermostat is for heating only and is suitable for ventilation systems in demanding industrial applications. It is designed for use in hazardous locations where specific explosive gases or dusts are present. The Ruffneck™ Defender® XT-411 thermostat is the only available explosion-proof thermostat for line voltage or pilot duty for up to 600 VAC.

More Features ... More Benefits:

- all aluminum exterior
- no breakable external plastic parts
- no exposed copper or brass
- corrosion resistant, suitable for H2S environments
- CFC & mercury free, no leveling required
- precision die cast components
- sensing bulb is protected by a sturdy thermowell
- impact resistant and will not lose its calibration set-point
- 600 VAC maximum
- compact and light-weight
- comes pre-wired for easy installation
- compatible with all previous and current Defender® thermostat housings
- compatible with all Ruffneck™ FX4 and FX5 heaters

Specifications

Temperature range: 40°F to 90°F (5°C to 30°C)

Temperature differential: 6.5°F (3.6°C)

Net weight: 3.1 lbs (1.41 kg)

Switching: Snap acting

Conduit opening: 3/4" - 14 NPT

Electrical Rating

600 VAC Max. (Canada) / 480 VAC Max. (US);

240V/30A (Canada and US)

480V/15A (Canada and US)

600V/15A (Canada Only)

Class I, Divisions 1 & 2, Groups C & D;
Class II, Division 1, Groups E, F & G;
Class II, Division 2, Groups F & G; Class III;
Class I, Zones 1 & 2, Groups IIA & IIB

Part Number

XT-411L

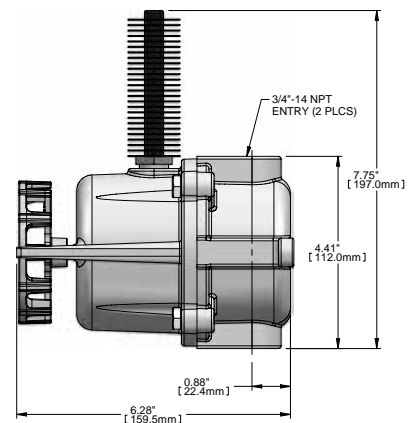
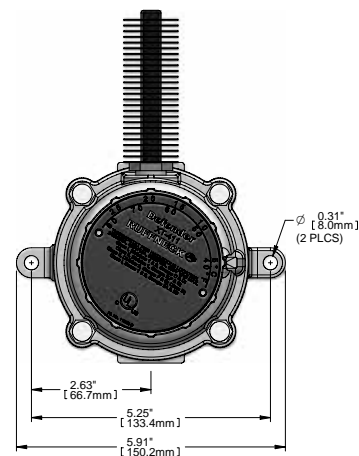

XT-411 Defender®



XTE-412 Defender® Electronic Thermostat

Ruffneck™ Defender® XTE-412 is engineered for use in the most demanding applications such as drilling rigs, utilidors and industrial facilities where severe service conditions exist.

The Ruffneck™ Defender® XTE-412 thermostat is for heating and cooling control in demanding industrial applications. It is designed for use in hazardous locations where explosive gases or dusts are present. The Ruffneck™ Defender® XTE-412 thermostat is available for line duty up to 240 VAC or pilot duty for up to 120 VAC.

Features

- all aluminum exterior
- no breakable external plastic parts
- no exposed copper or brass
- precision die cast components
- thermal sensor is protected by a sturdy thermowell
- 24V AC/DC, 120V / 240V AC
- compact and light-weight
- compatible with all previous and current Defender® thermostat housings
- microcontroller design
- electronic relay switch

Specifications

Temperature range: 32°F to 104°F (0°C to 40°C)

Temperature differential: 5.4°F (3°C)

Net weight: 3.1 lbs (1.41 kg)

Switching: Relay contact

Conduit opening: 3/4" NPT

Electrical Rating

Resistive: 240 VAC, N.O. 20 A, N.C. 10 A

Pilot Duty: 120 VAC, N.O. 470 VA, N.C. 275 VA

Hazardous Location Ratings

Class I, Divisions 1 & 2, Groups C & D;
Class II, Division 1, Groups E, F & G;
Class II, Division 2, Groups F & G; Class III;
Class I, Zones 1 & 2, Groups IIA & IIB

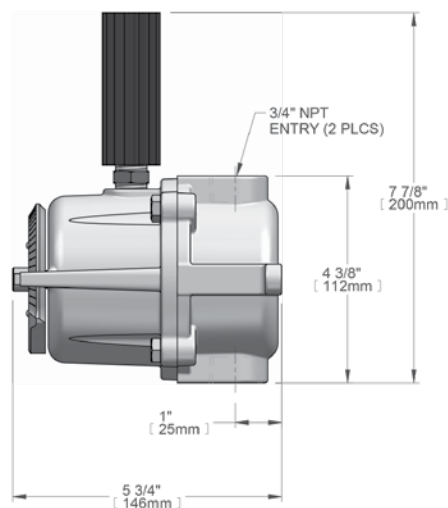
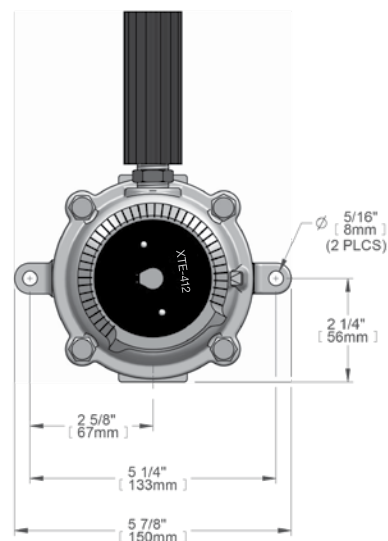

XTE-412 Defender®

Thermostats

ET5-S Standard Ruffneck™ Thermostat

Heavy Duty Line Voltage Thermostat



- Temperature range: 40°F to 80°F (5°C to 25°C)
- 22 amps, 277 VAC
- ¾ HP @ 125 VAC
- 1½ HP @ 250/277 VAC
- Single pole
- Single Throw*
- Approximate Shipping Weight: 0.6 lbs (0.28 kg)

TF115 NEMA 4X Corrosion Resistant Thermostat



- Temperature range: 40°F to 90°F (4°C to 30°C)
- 25 amps Res., 480 VAC Max.
- Full load = 16 amps @ 120 VAC
12 amps @ 240 VAC
Lock Rotor = 80 amps @ 120 VAC
60 amps @ 240 VAC
- single pole, double throw (heating or cooling applications)
- Approximate Shipping Weight: 0.69 lbs (0.31 kg)



XTB Explosion-Proof Thermostat

- Temperature range: 0°F to 100°F (-18°C to 40°C)
- Class I, Division 1 & 2 Groups C & D
Class II, Division 1 & 2 Groups E, F & G
Class III, Division 1 & 2
- Remote sensing bulb with 57" capillary length
- 15 amps Res., 600 VAC Max. - 25 amps Res., 277 Max.
- XTB04481 (Single Pole, Single Throw)*
- XTB04483 (Double Pole, Single Throw)*
- Approximate Shipping Weight: 3.8 lbs (1.7 kg)

XTWA Explosion-Proof Thermostat



- Temperature range: 0°F to 100°F (-18°C to 40°C)
- Class I, Division 1 & 2 Groups A, B, C & D
Class II, Division 1 & 2 Groups E, F & G
Class III, Division 1 & 2
- Sensing bulb in Finned Thermowell for Air Sensing
- 15 amps Res., 600 VAC Max. - 25 amps Res., 277 Max.
- XTWA04481 (Single Pole, Single Throw)*
- XTWA04483 (Double Pole, Single Throw)*
- Approximate Shipping Weight: 4.0 lbs (1.8 kg)

XTD8-S Explosion-Proof Thermostat



- Temperature range: 40°F to 80°F (5°C to 25°C)
- Class I, Division 1 & 2 Groups C & D
Class II, Division 1 & 2 Groups E, F & G
Class III, Division 1 & 2
- Feed-thru model (includes explosion-proof plug)
- ¾" - 14 NPT conduit opening (½" conduit adapter included)
- single pole, double throw (heating or cooling applications)
- 22 amps, 277 VAC Max.
- ¾ HP @ 125 VAC
- 1½ HP @ 250/277 VAC
- Approximate Shipping Weight: 5.3 lbs (2.4 kg)

Note:

All 3 phase motors on AH, HP and FR heaters require a motor starter (supplied by others).

*Heating applications only

ET5-S, XTB, XTWA, XTD8-S

Mounting Kits

Basic Mounting Kit (BMK)*

The BMK is suitable for applications where the support arm can be bolted or welded directly to structural steel or concrete.

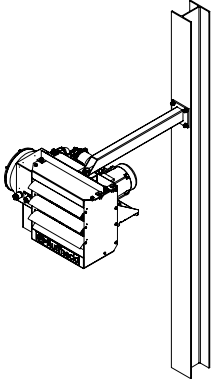

Model	Approximate Shipping Weight	
	lbs	kg
FX4/FX5 (12" / 305 mm fan)	16.5	7
FX4/FX5 (16" / 406 mm fan)	18.2	8
FX4/FX5 (20" / 508 mm fan)	19.3	9
HP / FR 12 / 16	16.5	7
HP / FR 20 / 24	18.2	8
AH-12A	16.5	7
AH-16A	18.2	8
AH-20A	19.3	9
AH-24A	20.3	9

Pipe Mounting Kit (PMK)*

Particularly useful in buildings with insufficient structural strength to use other types of mounts. Requires 3" (76 mm) pipe (3½" / 89 mm O.D.) (not supplied).

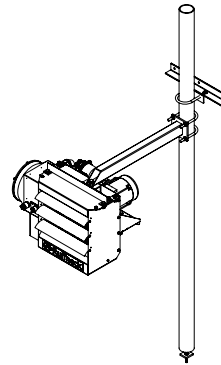

Model	Approximate Shipping Weight	
	lbs	kg
FX4/FX5 (12" / 305 mm fan)	23.7	11
FX4/FX5 (16" / 406 mm fan)	25.4	12
FX4/FX5 (20" / 508 mm fan)	26.5	12
HP / FR 12 / 16	23.7	11
HP / FR 20 / 24	25.4	12
AH-12A	23.7	11
AH-16A	25.4	12
AH-20A	26.5	12
AH-24A	27.5	12

Wall Mounting Kit (WMK)*

Ideal for use in buildings that have substantial walls. The Z sections provide additional support where necessary.

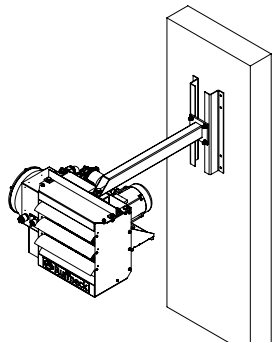

Model	Approximate Shipping Weight	
	lbs	kg
FX4/FX5 (12" / 305 mm fan)	24.3	11
FX4/FX5 (16" / 406 mm fan)	25.4	12
FX4/FX5 (20" / 508 mm fan)	26.5	12
HP / FR 12 / 16	24.3	11
HP / FR 20 / 24	25.4	12
AH-12A	24.3	11
AH-16A	25.4	12
AH-20A	26.5	12
AH-24A	27.5	12

Hanging Mounting Kit (HMK)

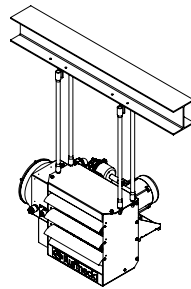

Simple and economical if an adequate overhead structure exists. Requires ½" (13 mm) pipe, cut and threaded (not supplied).

Model	Approximate Shipping Weight	
	lbs	kg
All FX4/FX5	4.5	2
All HP / FR	4.5	2
All AH	4.5	2

Swivel Hanging Mounting Kit (SHMK)*

Swivels 360°. Requires ½" (13 mm) pipe, cut and threaded (not supplied).

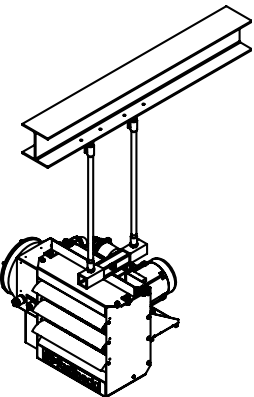

Model	Approximate Shipping Weight	
	lbs	kg
FX4/FX5 (12" / 305 mm fan)	18.2	8
FX4/FX5 (16" / 406 mm fan)	19.4	9
FX4/FX5 (20" / 508 mm fan)	20.4	9
HP / FR 12 / 16	18.3	8
HP / FR 20 / 24	20.1	9
AH-12A	18.2	8
AH-16A	19.4	9
AH-20A	20.4	9
AH-24A	21.4	10

Vertical Hanging Mounting Kit (VHMK)

Simple and economical when mounting to an appropriate overhead structure. (Requires 3/8" / 10 mm THD Rod)

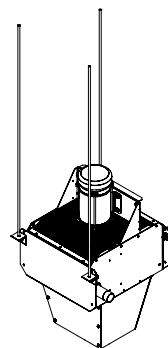

Model	Approximate Shipping Weight	
	lbs	kg
All AV	4.5	2

Notes:

Mounting kits are made of steel with wet applied enamel paint. If the heater is installed on a structure that is to be transported, provide additional support for the heater during transit. The suspended weight should not exceed 300 lbs (136 kg).

How To Order:

When ordering mounting kits, specify the type of kit required and the basic model of the heater to be mounted.

* Not suitable for models - HP 30, FR 30, HP 36, FR 36, or Tandem AH Series (24B fan configuration).

BMK, PMK, WMK, HMK, SHMK

Thermal Performance Analysis Service

You are encouraged to take advantage of our computerized service available for calculating heating capabilities for Ruffneck™ heat-exchanger unit heaters. This service accurately computes complete performance parameters and output capacities for all Ruffneck™ models under a wide range of operating conditions.

The software used is powerful and flexible, and offers metric or imperial unit measures to rate unit heaters based on flow rate or fluid temperature drop. The program is also designed to rate standard unit heaters; to rate heat-exchangers only for non-standard air flows in duct applications; or to quickly rate units for the following pre-programmed fluid types:

- Steam
- Ethylene Glycol / Water
- Water
- Triethylene Glycol / Water
- Dowtherm G
- Dowtherm A
- Dowtherm E
- Therminol FR-1
- Therminol 66
- Humbletherm 500
- Mobiltherm 600
- Sun 21 Thermal Oil
- SAE 20 Lube Oil
- SAE 30 Lube Oil

This program can also rate units for other fluids by manually inputting fluid properties.

CCI Thermal Technologies Inc. can provide long or short printouts of all calculations. All this can be performed quickly and easily by simply providing the following information:

- type of fluid used
- inlet fluid temperature
- outlet fluid temperature or available flow rate
- altitude above seal level
- entering air temperature

This service is particularly helpful for large complex projects requiring multiple heaters. We are able to perform dozens of calculations in search of the most economic system. Along with the thermal performance analysis, our staff can assist you with common heat loss calculations for your building.

CCI Thermal Technologies Inc. Thermal Performance Analysis Report

Date: 2000 / 10 / 11

Reference Data	
Job Description:	Test Data
Internet Browser used:	Microsoft Internet Explorer
Date: 2000 / 10 / 11	
Heater Data	
Advanced Series Model No.	AH-16A-B5
Number of Passes	5 Passes
Tube OD	1 in
Tube ID	0.834 in
Fin Spacing	9 fins / inch
Number of Rows	2 Rows
Fluid Properties @ Average Temperature	
Average Temperature	190 °F
Reynolds Number	10,999
Tubeside Conditions	
Fluid Flow Rate	3,820.82 lb/hr
Tubeside Flow Rate	7.12 USGPM@60°F
Tubeside Pressure Drop	0.19 psi
Input Data	
Fluid Name	50 % Ethylene Glycol by Weight
Operating Pressure	15 psig
Inlet Fluid Temperature	200 °F
Outlet Fluid Temperature	180 °F
Air Inlet Temperature	60 °F
Altitude	1500 ft ASL
Electric Motor Power	60 Hz
Any "Cautions" to note? None	
Airside Conditions	
Air Flow Rate	1,777 ACFM
Air Flow Rate (Standard Conditions)	1,713 SCFM
Air Velocity	759.14 FPM
Final Air Temperature	95.35 °F
Heater Performance Data	
Heat Dissipated (Total)	66,877 BTU/hr

Version: 1.01B4
Copyright 2004 by CCI Thermal Technologies Inc.
All rights reserved.

These reports are samples only.

Additionally, this program is available for your use, free of charge, from our web site at www.ccithermal.com.

Technical Data

PROPERTIES OF STEAM

GAUGE PRESSURE (psig)	TEMPERATURE °F (°C)	LATENT HEAT (Btu/lb)	DENSITY (lb/ft ³)
2	219 (104)	965	0.0434
10	239 (115)	952	0.0612
20	259 (126)	939	0.0855
40	287 (142)	919	0.1351
60	307 (153)	904	0.1818
80	324 (162)	891	0.2127
100	338 (170)	880	0.2564
150	366 (186)	857	0.3634
200	387 (197)	838	0.4686
250	406 (208)	820	0.5720
450	460 (238)	764	1.0000

ABBREVIATIONS USED

1. Btu = British Thermal Unit
2. MBH = Btu/hr × 1000
3. EAT = Entering Air Temperature
4. FAT = Final Air Temperature
5. USGPM = U.S. Gallons Per Minute
6. PD = Pressure Drop, psi
7. psig = Pounds Per Sq. In. Gauge Pressure
8. ΔT = Liquid Temperature Differential
9. CFM = Cubic Feet Per Minute
10. FPM = Feet Per Minute
11. COND. = Condensate Flow

USEFUL FORMULAS

1. Condensate, lb/hr = $\frac{\text{actual Btu/hr}}{\text{Latent Heat of Steam at psig}}$
2. Specific heat of air from 0°F to 150°F = 0.24 Btu/lb°F
3. Weight of one cubic foot of air at 70°F = 0.75 lb
4. Btu/hr = CFM × Air Temp. Rise (F°) × 1.08
(Note: 1.08 = 0.24 × 0.75 × 60)
5. Water temperature drop (F°) = $\frac{\text{actual Btu/hr}}{500 \times \text{USGPM}}$
6. CFM at FAT = CFM at 70°F × $\frac{460 + \text{FAT}}{530}$
7. CFM at 70°F = CFM at FAT × $\frac{530}{460 + \text{FAT}}$
8. Air temperature rise (F°) = $\frac{\text{actual Btu/hr}}{1.08 \times \text{CFM}}$
9. Final air temperature (°F) = EAT + Temp. Rise
10. 1 Boiler Horsepower = 33,479 Btu/hr at 70 psi
11. 1 Boiler Horsepower = 30 lbs/hr of feed water at 100°F converted to steam at 70 psi
12. 1 U.S. Gallon of water = 8.34 pounds of water
13. 1 Imperial Gallon of water = 10 pounds of water
14. 1 psi pressure drop = 27.6 inches of water
15. 1 kW = 3,414 Btu/hr
16. 1 U.S. Gallon = 0.83267 Imperial Gallons
17. 1 U.S. Gallon = 3.785 litres
18. °C = 5/9 (°F - 32)

EQUIVALENT RESISTANCE OF VALVES AND FITTINGS

PIPE SIZE IN	Feet of Pipe							
	GLOBE VALVE OPEN	GATE VALVE OPEN	CLOSER RETURN BEND	TEE 90° FLOW	TEE 0° FLOW	ELBOW 90° STANDARD	ELBOW 45° STANDARD	REDUCER D/d = 2
1	27	1.1	6	6	1.7	2.6	1.3	1.0
1¼	37	1.3	8	8	2.3	3.5	1.6	1.3
1½	44	1.6	10	9	2.7	4.5	2.0	1.5
2	55	2.2	13	12	3.5	5.3	2.5	1.9
2½	65	2.7	15	14	4.2	6.3	3.0	2.2
3	80	3.3	18	17	5.0	8.0	3.7	2.8

HEAT LOSS OF STEAM LINES

Heat loss of uncovered steam lines in a 15 MPH wind:

$$\text{Btu/hr} = \text{td} \times \text{C} \times \text{S}$$

WHERE: td = temperature difference between steam and ambient air

- C = 5.32 for 200 F° td
- 5.92 for 250 F° td
- 6.52 for 300 F° td
- 7.29 for 350 F° td
- 8.06 for 400 F° td

S = surface area of pipe in square feet

EXAMPLE: Calculate heat loss for one foot of 2" (51 mm) pipe at 316°F (70 psi) steam temperature inside, with an ambient air temperature of -34°F outside.

$$\text{td} = 350 \text{ F}^\circ (-34^\circ\text{F to } 316^\circ\text{F})$$

$$\text{C} = 7.29$$

$$\text{S} = \frac{2.375'' \text{ O.D.} \times \pi \times 12''}{144 \text{ sq.in.} / \text{sq.ft}} = 0.6218$$

$$\text{Heat Loss} = 350 \times 7.29 \times 0.6218 = 1587 \text{ Btu/hr}$$

BABCOCK FORMULA FOR STEAM FLOW

$$\text{PRESSURE DROP (psi)} = \frac{0.0001307W^2L}{p \cdot d^5} \left(1 + \frac{3.6}{d}\right)$$

WHERE: W = Steam Flow Rate, lb per minute

L = Length of Pipe, ft

- p = 0.0434 for 2 psig Steam
- 0.0612 for 10 psig Steam
- 0.0855 for 20 psig Steam
- 0.1351 for 40 psig Steam
- 0.1818 for 60 psig Steam
- 0.2127 for 80 psig Steam
- 0.2564 for 100 psig Steam

d = Inside diameter of Pipe, inches

EXAMPLE: Calculate pressure drop for 100 ft of 2" (1 mm) sch. 40 pipe used to deliver all the steam of a 100 h.p. boiler (3000 lb/hr) at 80 psi.

where: W = 50, L = 100, p = 0.2127, d = 2.067

$$\text{Pressure Drop (psi)} = \frac{0.0001307 \times 50^2 \times 100}{0.2127 \times 2.067^5} \left(1 + \frac{3.6}{2.067}\right)$$

$$\text{Pressure Drop} = 11.16 \text{ psi}$$

ENGINEER'S SPECIFICATIONS

Supply and install Ruffneck™ Heat-Exchanger Unit Heaters as shown on the following plans.

For FR-1 and HP-1 Series in fluid applications, including standard features listed below.

-----DESCRIPTION-----			-----PERFORMANCE-----			-----MOTOR-----		
Item	Quantity	Model	MBH @ psi @ EAT	FAT	Type	Volts	Phase	Hertz

FR Series units shall be suitable for use on steam pressures to 100 psi and shall be warranted against frost damage for a period of one year.

For HP-1, HP-3, HP-5, HP-7 Series in fluid applications, including standard features listed below.

For use on _____ (type of liquid)

-----DESCRIPTION-----			-----PERFORMANCE-----			-----MOTOR-----		
Item	Quantity	Model	MBH @ psi @ EAT	FAT	Type	Volts	Phase	Hertz

HP series units shall be suitable for use on pressures up to ____ psi (400 psi available on select models) and shall be warranted for a period of one year.

Standard features for all models

Cabinet

Cabinet shall be an all-welded design of 14 GA steel (12 GA on model 36) and shall be 5-stage phosphate treated and finished with a powder coated green-grey epoxy. Louvre blades shall be adjustable heavy duty type. Motor mount shall be of heavy-duty formed steel construction.

Heat Exchanger

Shall be a heavy-duty welded steel construction using 5/8" (16 mm) dia. x .065" (1.7 mm) average wall thickness carbon steel tubing with tension wound close fitting .014" (3.6 mm) thickness x 7/16" (11 mm) high aluminum fins. Inlet and outlet connections are to be 2" NPT female extra heavy-duty steel type. Completed heat exchangers shall have heat resistant aluminum paint applied. The entire assembly shall be warranted for a period of one year against damage due to over-torquing.

Fan

Shall be an accurately balanced 3-wing design employing aluminum propeller blades, riveted to a steel hub, driven directly by the motor (size 36 models shall use a balance 6-wing, painted, all-steel, belt driven fan).

Fan Guard

The fan shall be shielded with a heavy-duty epoxy coated guard. To provide easy maintenance and cleaning of the fan and motor, the fan guard shall be of a two-piece construction. Gaps in guard not to exceed 1/4" (6 mm). (Size 36 models shall be welded design of perforated sheet steel, powder coated to match the heater).

Motor

Shall be UL listed and/or CSA approved permanently lubricated ball bearing type with rigid base (Type, voltage, phase, hertz, etc. as required).

Hazardous Locations Definitions

The following information is to be used only as a general reference. For detailed information concerning hazardous location definitions and installation requirements, refer to either the 1999 National Electrical Code (NEC), Chapter 5 Articles 500 through 516, available from the National Fire Protection Association, or the 1998 Canadian Electrical Code (CEC), Part 1 Section 18, available from the Canadian Standards Association.

Hazardous Locations: Areas where fire or explosion hazards exist due to the possible presence of flammable gases or vapors, flammable liquids, combustible dusts, or ignitable fibers or flyings.

NEC and CE Classification System

- Class I Locations** A location where there is a danger of explosion due to the presence of a flammable gas or vapor.
- Class II Locations** A location where there is a danger of explosion due to the presence of a flammable dust.
- Class III Locations** A location where there is a danger of explosion due to the presence of flammable fibers or flyings.
- Division 1 Locations** A location where the hazard is expected to be present during normal operating conditions.
- Division 2 Locations** A location where the hazards would only exist as a result of an accident or other abnormal event, such as an accidental rupture of a vessel or container or failure of a ventilating system.

Class I Groups

- Group A** Atmospheres containing acetylene.
- Group B** Atmospheres containing hydrogen (H₂), fuel and combustible process gases containing more than 30% hydrogen by volume, or gases or vapors of equivalent hazard such as butadiene, ethylene oxide, propylene oxide, and acrolein.
- Group C** Atmospheres containing ethyl ether, ethylene, or gases or vapors of equivalent hazard.
- Group D** Atmospheres containing acetone, alcohol, ammonia, benzene, butane, cyclopropane, ethanol, gasoline, hexane, methanol, methane, natural gas, propane, or gases or vapors of equivalent hazard.

Class II Groups

- Group E** Atmospheres containing combustible metal dusts, including aluminum, magnesium, and their commercial alloys, or other combustible dusts whose particle size, abrasiveness, and conductivity present similar hazards in the use of electrical equipment.
- Group F** Atmospheres containing combustible carbonaceous dusts including coal, coke, carbon black, and charcoal dust having more than 8% total entrapped volatiles; or dusts that have been sensitized by other materials so that they present an explosion hazard.
- Group G** Atmospheres containing combustible dusts not included in Group E or F, including flour, starch, grain, wood, plastic, and chemicals.

CENELEC (and IEC) Zone Classification System

Introduced to North America in 1996, the European CENELEC (and IEC) system of classification of hazardous locations is also permitted to apply to installations in the U.S. and Canada as an alternative in Class I Locations, and is now part of the NEC (Article 505) and CE Code (Section 18).

- Class I, Zone 0** A location in which explosive gas atmospheres are present continuously or for long periods of time.
- Class I, Zone 1** A location in which explosive gas atmospheres are likely to exist in normal operation or may exist frequently because of repairs, maintenance operations, and leakage or where equipment breakdowns could release gases or vapors and also cause simultaneous failure of electrical equipment in a mode to cause the electrical equipment to become a source of ignition.
- Class I, Zone 2** A location in which explosive gas atmospheres are not likely to occur in normal operation and, if they do occur, will exist for a short time only; or where volatile flammable liquids, flammable gas, or flammable vapors are handled, processed, or used, but are normally confined within closed containers or systems from which they can escape only as a result of accidental rupture or breakdown of the containers or system, or as a result of abnormal operation of the equipment with which the liquids or gases are handled, processed, or used; or where ignitable concentrations of flammable gases or vapors are normally prevented by adequate ventilation, but which may occur as a result of failure or abnormal operation of the ventilation system.

Class I Groups

- Group I** Atmospheres containing explosive gas in underground coal mines. Electrical apparatus that is intended for use in underground mines.
- Group IIC** Atmospheres containing acetylene, hydrogen (H₂), or gases of equivalent hazard.
- Group IIB** Atmospheres containing acetaldehyde, ethylene, or gases or vapors of equivalent hazard.
- Group IIA** Atmospheres containing acetone, ammonia, ethyl alcohol, gasoline, methane, propane, or gases or vapors of equivalent hazard.

Notes:

There is potential for confusion between the NEC/CE and IEC gas classification systems since the Group letters are reversed and even combined. Care should also be taken to avoid confusing Group II and Class II, since both use Roman numerals. An unintended result of specifying the IEC gas groups, which combine the traditional Groups A and B into Group IIC, is that equipment approved for hydrogen (H₂) would also have to be approved for acetylene. Since very little equipment is designed for acetylene, the wording as originally adopted severely limits the availability of equipment for hydrogen applications. As a result, NEC Section 505-7(d) now allows for equipment to be listed for a specific gas or vapor, specific mixtures of gases or vapors, or any specific combination of gases or vapors. One common example is equipment marked for "IIB + H₂". At present, the NEC or CE Code does not recognize any CENELEC or IEC dust classifications.

Combustion Principles

Three basic conditions must be satisfied for a fire or explosion to occur. First, a flammable liquid, vapor or combustible dust must be present in sufficient quantity. Second, the flammable liquid, vapor or combustible dust must be mixed with air or oxygen in the proportions required to produce an explosive mixture. Finally, a source of energy must be applied to the explosive mixture.

In applying these principles, the quantity of the flammable liquid or vapor that may be liberated and its physical characteristics must be recognized. Vapors from flammable liquids also have a natural tendency to disperse into the atmosphere, and rapidly become diluted to concentrations below the lower explosion limit, particularly when there is natural or mechanical ventilation. In order to have an explosive gas atmosphere, the concentration of the gas or vapor must be above the Lower Explosive Ignition Limit (LEL) but below the Upper Explosive Limit (UEL). The possibility that the gas concentration may be above the upper explosion limit does not afford any degree of safety, as the concentration must first pass through the explosive range to reach the upper explosion limit.

Combustion Triangle

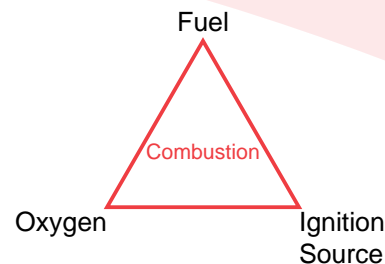

Equipment Marking Requirements

Electrical equipment permitted for use in hazardous locations must be marked to show the Class, Division (or Zone under NEC Article 505 and CEC Section 18), Group, and maximum surface operating temperature or temperature code referenced to a 104°F (40°C) ambient temperature (some exceptions apply). Note that the maximum external temperature of the equipment shall not exceed the minimum ignition temperature of the atmosphere that the equipment is located in.

Electrical equipment approved for operation at ambient temperatures exceeding 104°F (40°C) shall be marked with the maximum ambient temperature for which the equipment is approved, and the operating temperature or temperature range at that ambient temperature.

Equipment not marked to indicate a division, or marked "Division 1" or "Div. 1", is suitable for both Division 1 and 2 locations. Equipment marked "Division 2" or "Div. 2" is suitable for Division 2 locations only. Equipment that is listed for a Zone 0 location shall be permitted in a Zone 1 or Zone 2 location of the same gas or vapor. Equipment that is listed for a Zone 1 location shall be permitted in a Zone 2 location of the same gas or vapor.

Maximum Surface Temperature Codes

Maximum Surface Temperature °F (°C)	Identification Number	
	NEC/CEC T-Code	IEC T-Code
842°F (450°C)	T1	T1
572°F (300°C)	T2	T2
536°F (280°C)	T2A	
500°F (260°C)	T2B	
446°F (230°C)	T2C	
419°F (215°C)	T2D	
392°F (200°C)	T3	T3
356°F (180°C)	T3A	
329°F (165°C)	T3B	
320°F (160°C)	T3C	
275°F (135°C)	T4	T4
248°F (120°C)	T4A	
212°F (100°C)	T5	T5
185°F (85°C)	T6	T6

Hazardous Location Definitions



Heaters for the Harshest Environments

5918 Roper Road, Edmonton, Alberta, Canada T6B 3E1

Phone: (780) 466-3178 Fax: (780) 468-5904

PLEASE ADHERE TO INSTRUCTIONS PUBLISHED IN THIS MANUAL. Failure to do so may be dangerous and may void certain provisions of your warranty. For further assistance, please call:

24 Hr. Hotline: 1-800-661-8529 (U.S.A. and Canada) Please have model and serial numbers available before calling.

WARRANTY: Under normal use the Company warrants to the purchaser that defects in material or workmanship will be repaired or replaced without charge for a period of 18 months from date of shipment, or 12 months from the start date of operation, whichever expires first. Any claim for warranty must be reported to the sales office where the product was purchased for authorized repair or replacement within the terms of this warranty. Subject to State or Provincial law to the contrary, the Company will not be responsible for any expense for installation, removal from service, transportation, or damages of any type whatsoever, including damages arising from lack of use, business interruptions, or incidental or consequential damages. The Company cannot anticipate or control the conditions of product usage and therefore accepts no responsibility for the safe application and suitability of its products when used alone or in combination with other products. Tests for the safe application and suitability of the products are the sole responsibility of the user. This warranty will be void if, in the judgment of the Company, the damage, failure or defect is the result of: vibration, radiation, erosion, corrosion, process contamination, abnormal process conditions, temperature and pressures, unusual surges or pulsation, fouling, ordinary wear and tear, lack of maintenance, incorrectly applied utilities such as voltage, air, gas, water, and others or any combination of the aforementioned causes not specifically allowed for in the design conditions or any act or omission by the Purchaser, its agents, servants or independent contractors which for greater certainty, but not so as to limit the generality of the foregoing, includes physical, chemical or mechanical abuse, accident, improper installation of the product, improper storage and handling of the product, improper application or the misalignment of parts. No warranty applies to paint finishes except for manufacturing defects apparent within 30 days from the date of installation. The Company neither assumes nor authorizes any person to assume for it any other obligation or liability in connection with the product(s). The Purchaser agrees that all warranty work required after the initial commissioning of the product will be provided only if the Company has been paid by the Purchaser in full accordance with the terms and conditions of the contract. The Purchaser agrees that the Company makes no warranty or guarantee, express, implied or statutory, (INCLUDING ANY WARRANTY OF MERCHANTABILITY OR WARRANTY OF FITNESS FOR A PARTICULAR PURPOSE) written or oral, of the Article or incidental labour, except as is expressed or contained in the agreement herein. LIABILITY: Technical data contained in the catalog or on the website is subject to change without notice. The Company reserves the right to make dimensional and other design changes as required. The Purchaser acknowledges the Company shall not be obligated to modify those articles manufactured before the formulation of the changes in design or improvements of the products by the Company. The Company shall not be liable to compensate or indemnify the Purchaser, end user or any other party against any actions, claims, liabilities, injury, loss, loss of use, loss of business, damages, indirect or consequential damages, demands, penalties, fines, expenses (including legal expenses), costs, obligations and causes of action of any kind arising wholly or partly from negligence or omission of the user or the misuse, incorrect application, unsafe application, incorrect storage and handling, incorrect installation, lack of maintenance, improper maintenance or improper operation of products furnished by the Company.

Edmonton Head Office 1-800-661-8529 (780) 466-3178

Oakville 1-800-410-3131 (905) 829-4422 F 905-829-4430

Orillia 1-877-325-3473 (705) 325-3473 F 705-325-2106

Houston 1-855-219-2101 (281) 506-2310 F 281-506-2316

Denver (303) 979-7339 F 303-979-7350

Warranty



As a leader in advanced heating and filtration solutions with facilities across North America, CCI Thermal Technologies Inc. manufactures six of the top brands in industrial heating in addition to a comprehensive line of engineered industrial filtration products including:



Cata-Dyne™ is the industry standard in infrared gas catalytic heaters, enclosures, pipeline systems and accessories. Customers across a wide range of industries rely on Cata-Dyne™ to supply them with safe, reliable, efficient and versatile infrared catalytic heating equipment for a variety of applications in both hazardous and non-hazardous environments.

Ruffneck™ is renowned for its rugged, reliable and versatile heavy-duty explosion-proof heaters, heating systems and heating accessories. Ruffneck™ has a long and proud history of supplying quality heating products for the harshest industrial environments to a worldwide customer base for over 30 years. Ruffneck™ is well-known in the industry for its "ship the heat in a week" policy, where 95% of all standard orders are shipped within one week of order placement.



Caloritech™ electric heaters, heating elements and heating accessories are well-known in the industry for their quality, reliability, performance and versatility. In addition to standard "off the shelf" industrial heaters and heating systems components, Caloritech™ also offers engineered heating solutions custom designed, manufactured and tested to satisfy customer specifications. No matter what your application or environment, Caloritech™ has a solution to fit your heating needs.

3L Filters™ has satisfied the most demanding industrial filtration requirements for over 40 years. A broad range of standard and custom products includes liquid filters, strainers, separators, pressure vessels, and engineered products and systems. 3L Filters™ has special expertise for nuclear, petrochemical, water treatment and environmental applications.



Norseman™ is the most technologically advanced line of explosion-proof electric air heaters and heating accessories, including both forced air heaters and natural convection heaters, as well as unit heaters, panel heaters and thermostats. Norseman™ offers innovative, low maintenance solutions for a wide range of applications in a variety of industrial and commercial environments. Custom engineered heaters or heating systems are available for specialized applications.

Fastrax® has manufactured railroad track and switch heating since 1995. Fastrax® engineers complete heating packages for the rail industry. Fastrax® track and switch heaters are designed to provide the most efficient heat transfer on rail equipment and components for the coldest environments. In addition to heaters, Fastrax® manufactures fully automatic energy saving controls to complete the rail heating system.



DriQuik™ provides components for infrared drying ovens. DriQuik™ utilizes a pioneered radiant oven technology established in the 1930s providing the industry standard in infrared radiant heating components.

VISIT WWW.CCITHERMAL.COM FOR DETAILED PRODUCT INFORMATION.

Edmonton, AB

Head Office
1-800-661-8529
(780) 466-3178
F 780-468-5904

Oakville, ON

1-800-410-3131
(905) 829-4422
F 905-829-4430

Orillia, ON

1-877-325-3473
(705) 325-3473
F 705-325-2106

Houston, TX

1-855-219-2101
(281) 506-2310
F 281-506-2316

Denver, CO

1-855-244-3128
(303) 979-7339
F 303-979-7350