



marath•n



Tire Manual

Northern Tool Item #: 189420

Marathon Part #: 32081

Description: Flat Free, 3.50/2.50-8" ribbed; 5/8" bearing bore; 3" hub

Contents



Safety Information	3
Customer Service.....	3
Tire Spec. Information	4
Tire Uses	4
Installation Instructions	5
Bearing Replacement	6

1. Safety Information

Use gloves to install



Wear safety glasses



Not for highway use.

Customer Service

If you have any questions regarding this product, please don't hesitate to contact us.

Toll Free

877-425-1640
253-893-7021

Online

Email: sales@marathonind.com
Website: www.marathonind.com

How-To Videos

If you have any doubts, check out our [How-To videos online](#)

2. Tire Spec. Information

Northern Tool Item #: 189420

Marathon Part #: 32081

Description: Flat Free, 3.50/2.50-8" ribbed; 5/8" bearing bore; 3" hub

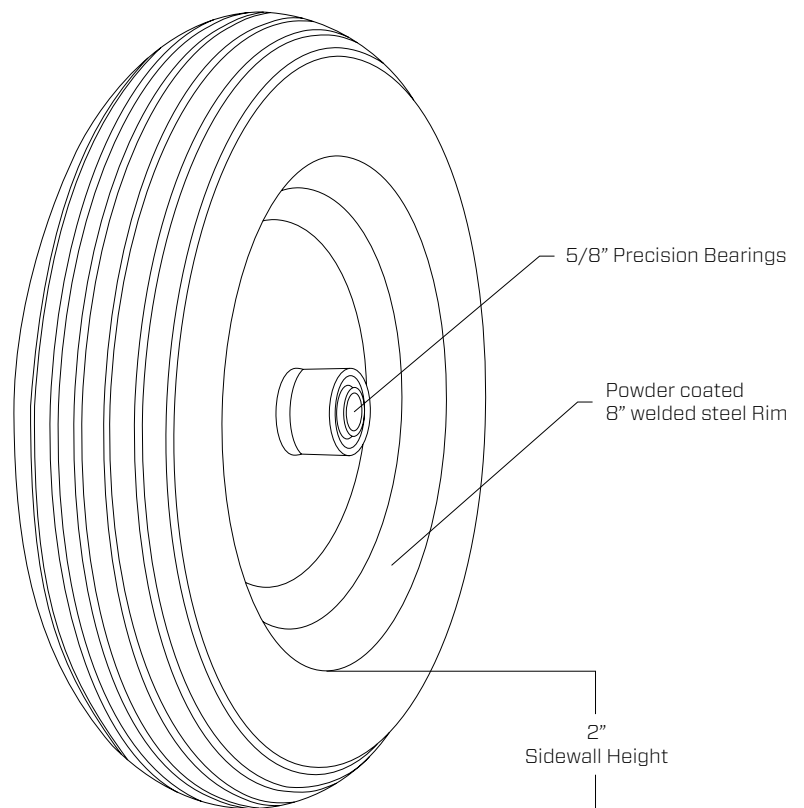
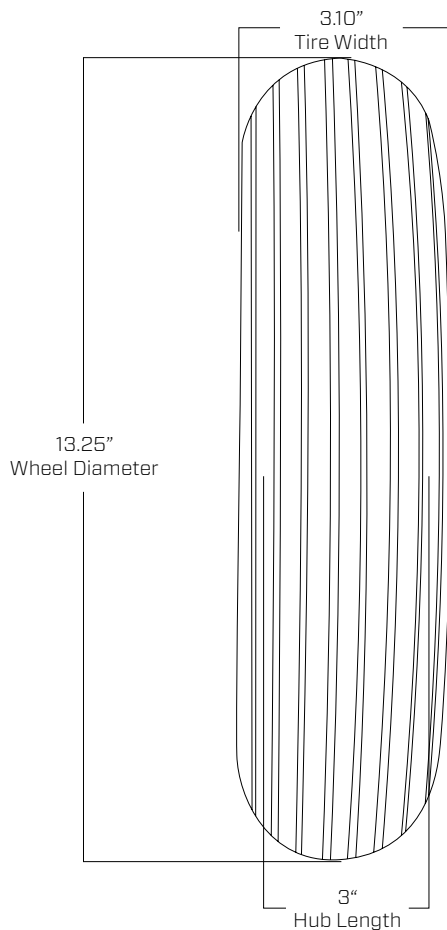

Tire Uses



Wheelbarrow



Trailer Cart

3. Installation Instructions

Note:

These installation instructions apply for installation on most standard wheelbarrows. For installation on other equipment, please see original equipment manufacturer's manual.

You will need: Crescent Wrench, New Wheelbarrow Tire, Gloves and Eye Protection

1

Step One:

Put on your gloves and eye protective-wear.

Use your crescent wrench to unscrew the axle brackets that attach the axle to the wheelbarrow. Remove brackets on both sides (*Fig. 1*).

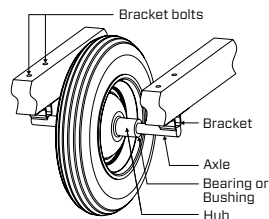

Fig. 1

3

Step Three:

Replace brackets onto each end of the axle and rest the brackets into place on your wheelbarrow. Make sure the tire is tight on your axle and cannot move from side to side.

2

Step Two:

Remove the axle from the tire and set the axle aside. Dispose of your old tire. Get your new wheelbarrow tire and place the axle through the center (*Fig. 2*).

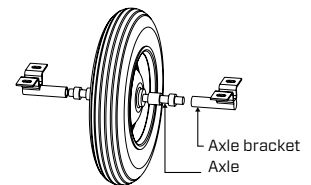

Fig. 2

4

Step Four:

Reattach your axle brackets to the wheelbarrow. Tighten the brackets with a crescent wrench only after you are sure the tire spins freely on the axle and isn't moving from side to side.

Helpful Hint:

If the tire moves from side to side on your axle, add spacers or washers along the axle on each side of the tire until the tire no longer moves.

Videos:

For a demonstration video, please visit the following link:

http://youtu.be/_kshk-qhOeM

4. Bearing Replacement

You will need: hammer, screwdriver, block of wood, replacement bearings, gloves and eye protection.

1

Step One:

Prop the tire up to allow room for the bearings to be removed from the hub. For example, you may use a bucket.

2

Step Two:

Place the screwdriver through the bearing hole until it hits the backside of the bearing on the opposite side.

3

Step Three:

Hit the top of the screwdriver with a hammer until the bearing pops out into the bucket below (*Fig. 1*).

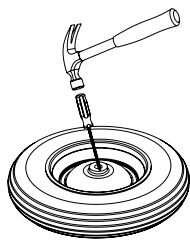

Fig. 1

4

Step Four:

Turn the tire over and repeat steps 1-3 so that both bearings are removed from the hub.

6

Step Six:

Hammer directly onto the block of wood to get the bearing in the hub (the wood block will give you a more even hit). This will require a few hard pounds (*Fig. 2*). Repeat on the other side to install both bearings.

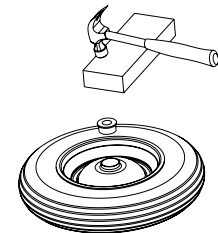

Fig. 2

5

Step Five:

To reinstall bearings, rest the new bearing on the opening in the hub and place the block of wood on top of the bearing to avoid hitting the bearing directly (*Fig. 2*).

Helpful Hints:

If the bearing drops freely into the hub prior to hitting with a hammer, remove the bearings and tap gently along the edge of the hub to create a tighter fit for the bearing.

Change location on the backside of the bearing periodically for easier removal.

The logo for Marathon is displayed in a black rounded rectangle. The word "marathon" is written in a bold, lowercase, sans-serif font. The letter "o" is replaced by a white circle with a black dot in the center, resembling a wheel or a tire tread. The background of the entire page is a light yellow color with a large, faint, circular watermark of a tire tread pattern.

marathon

Toll Free

877-425-1640

253-893-7021

Email: sales@marathonind.com

Website: www.marathonind.com