



4000-Lb. Adjustable Gantry Crane

Owner's Manual



! **WARNING:** Read carefully and understand all ASSEMBLY AND OPERATION INSTRUCTIONS before operating. Failure to follow the safety rules and other basic safety precautions may result in serious personal injury.

Item# 5071182

READ & SAVE THESE INSTRUCTIONS

Thank you very much for choosing a Strongway product!

For future reference, please complete the owner's record below:

Serial Number/Lot Date Code (if applicable):

Purchase Date: _____ -

Save the receipt, warranty, and this manual. It is important that you read the entire manual to become familiar with this product before you begin using it.

This product is designed for certain applications only. Northern Tool and Equipment is not responsible for issues arising from modification or improper use of this product such as an application for which it was not designed. We strongly recommend that this product not be modified and/or used for any application other than that for which it was designed.

For technical questions, please call **1-800-222-5381**.

Table of Contents

| | |
|------------------------------------|----|
| Intended Use..... | 4 |
| Packaging Contents..... | 4 |
| Technical Specifications | 4 |
| Important Safety Information | 4 |
| Specific Operation Warnings | 6 |
| Main Parts of Crane | 6 |
| Assembly Instructions..... | 7 |
| Before Each Use..... | 11 |
| Operating Instructions..... | 13 |
| After Each Use..... | 15 |
| Maintenance | 15 |
| Troubleshooting | 17 |
| Parts Diagram | 18 |
| Parts List..... | 19 |
| Replacement Parts | 19 |
| Limited Warranty..... | 20 |

Intended Use

This 4000-Lb. Adjustable Gantry Crane is made of heavy-duty, all steel construction and is ideal for shops where lifting is an essential part of the business. It goes where forklifts can't. Quick assembly and disassembly allow for easy transport within a jobsite or from site to site. The auto-lock feature keeps unit secure. Super-strong casters with rubber roll smoothly. The gantry crane is NOT to be moved while loaded.

Packaging Contents

- | |
|---|
| <ul style="list-style-type: none">• Part A (3) |
| <ul style="list-style-type: none">• I-Beam (1) |
| <ul style="list-style-type: none">• Base (2) |
| <ul style="list-style-type: none">• Other parts |

Technical Specifications

| Property | Specification |
|------------------|---------------------|
| Load Capacity | 4000 lb. |
| I-Beam to Ground | 99 1/5" to 146 1/2" |
| Width | 47 1/4" |
| Flange Width | 93 1/4" |
| I-Beam Height | 7 1/10" |

Important Safety Information

⚠WARNING

- Read and understand all instructions. Failure to follow all instructions may result in serious injury or property damage.
- The warnings, cautions, and instructions in this manual cannot cover all possible conditions or situations that could occur. Exercise common sense and caution when using this tool. Always be aware of the environment and ensure that the tool is used in a safe and responsible manner.
- Do not allow persons to operate or assemble the product until they have read this manual and have developed a thorough understanding of how it works.
- Do not modify this product in any way. Unauthorized modification may impair the function and/or safety and could affect the life of the product. There are specific applications for which the product was designed.
- Use the right tool for the job. DO NOT attempt to force small equipment to do the work of larger industrial equipment. There are certain applications for which this equipment was designed. This product will be safer and do a better job at the capacity for which it was intended. DO NOT use this equipment for a purpose for which it was not intended.
- Industrial or commercial applications must follow OSHA requirements.

⚠️WARNING

WORK AREA SAFETY

- Inspect the work area before each use. Keep work area clean, dry, free of clutter, and well-lit. Cluttered, wet, or dark work areas can result in injury. Using the product in confined work areas may put you dangerously close to cutting tools and rotating parts.
- Do not use the product where there is a risk of causing a fire or an explosion; e.g., in the presence of flammable liquids, gases, or dust. The product can create sparks, which may ignite the flammable liquids, gases, or dust.
- Keep children and bystanders away from the work area while operating the tool. Do not allow children to handle the product.
- Be aware of all power lines, electrical circuits, water pipes, and other mechanical hazards in your work area. Some of these hazards may be hidden from your view and may cause personal injury and/or property damage if contacted.

⚠️WARNING

PERSONAL SAFETY

- Stay alert, watch what you are doing, and use common sense when operating the tool. Do not use the tool while you are tired or under the influence of drugs, alcohol, or medication. A moment of inattention while operating the tool may result in serious personal injury.
- Dress properly. Do not wear loose clothing, dangling objects, or jewelry. Keep your hair, clothing and gloves away from moving parts. Loose clothes, jewelry, or long hair can be caught in moving parts. Air vents on the tool often cover moving parts and should be avoided.
- Wear the proper personal protective equipment when necessary. Use ANSI Z87.1 compliant safety goggles (not safety glasses) with side shields, or when needed, a face shield. Use a dust mask in dusty work conditions. Also use non-skid safety shoes, hardhat, gloves, dust collection systems, and hearing protection when appropriate. This applies to all persons in the work area.
- Do not overreach. Keep proper footing and balance at all times.

⚠️CAUTION

CRANE USE AND CARE

- Do not force the crane. Products are safer and do a better job when used in the manner for which they are designed. Plan your work, and use the correct product for the job.
- Check for damaged parts before each use. Carefully check that the product will operate properly and perform its intended function. Replace damaged or worn parts immediately. Never operate the product with a damaged part.
- Do not use a product with a malfunctioning switch. Any power tool that cannot be controlled with the power switch is dangerous and must be repaired by an authorized service representative before using.

Disconnect the power/air supply from the product and place the switch in the locked or off position before making any adjustments, changing accessories, or storing the tool. Such preventive safety measures reduce the risk of starting the tool accidentally.

- Store the product when it is not in use. Store it in a dry, secure place out of the reach of children. Inspect the tool for good working condition prior to storage and before re-use.
- Use only accessories that are recommended by the manufacturer for use with your product. Accessories that may be suitable for one product may create a risk of injury when used with another tool. Never use an accessory that has a lower operating speed or operating pressure than the tool itself.

Specific Operation Warnings

⚠️ WARNING

- To prevent serious injury or property damage, read and understand the owner's manual before use.
- Do not exceed the rated load capacity.
- Operate on a hard, level surface.
- Do not operate crane if the beam is not level.
- Be sure the trolley stoppers have been fixed to both ends of the beam.
- Ensure the load is centered before lifting.
- Do not use to lift people or animals.
- Keep persons and property clear from under the load.
- Do not leave loads suspended when the gantry crane is unattended.
- Do not allow the load to swing or roll against the support members.
- Inspect the crane for damaged parts and loose bolts before each use.
- Do not use the crane if there are damaged parts. Replace damaged parts before continuing use.
- Do not adjust height or disassemble crane while loaded.
- Secure trolley and hoist in the center of the beam when adjusting height.
- Do not push or pull crane with a forklift or other vehicle.
- Never push the load when trying to move the crane. Always push the crane.
- When moving crane while loaded, keep the load close as close to the floor as possible and position the load in the center of the beam.
- Do not anchor the legs to the floor.
- Secure the trolley and hoist in the center of the beam when adjusting the height.

Main Parts of Crane

| Reference | Subassembly |
|-----------|--------------------------|
| 1 | 6" Locking Swivel Caster |
| 2 | Base |
| 3 | Post Sleeve |
| 4 | Post Support |
| 5 | I-Beam |
| 6 | Handle |

Assembly Instructions

⚠WARNING

- TO PREVENT SERIOUS INJURY AND DEATH: Wear ANSI-approved safety goggles, hard hat, heavy-duty work gloves, and steel-toed work boots during assembly and operation.
- The correct bolts must be used during assembly. If any doubts arise regarding proper assembly, contact Northern Tool + Equipment before use.

Assembly Set-up

1. More than one person will be needed for assembly.
2. Use a large, clean and uncluttered area for assembly.
3. Consider vertical clearance when choosing operation area. Assemble close to operation area.
4. Use saw horses (not included) to support larger items such as Posts and I-Beam during assembly.
5. The Post Insert (7) and Post Sleeve (3) are pre-assembled.

Threaded
Shaft Size



Attaching Posts and Connector Plate A & B to I-Beam



(16) Bolt M14 x 40 (15) Washer Φ 14 (17) Nut M14 (24) Spring Washer Φ 14

1. Lay I-Beam (8) on the ground. Lay left and right Post Assemblies on the ground.
2. Attach Left Post Insert (7) to I-Beam (8), using Bolts (16), Washers (15), Nuts (17), and Spring Washers (24). Each Bolt (16) needs 1 washers (15).

3. Tighten connections securely

4 Repeat for Right Post Assembly.

5. Attach Left Connector Plate A (9) and Left Connect Plate B (10) to I-Beam (8), using Bolts (16),

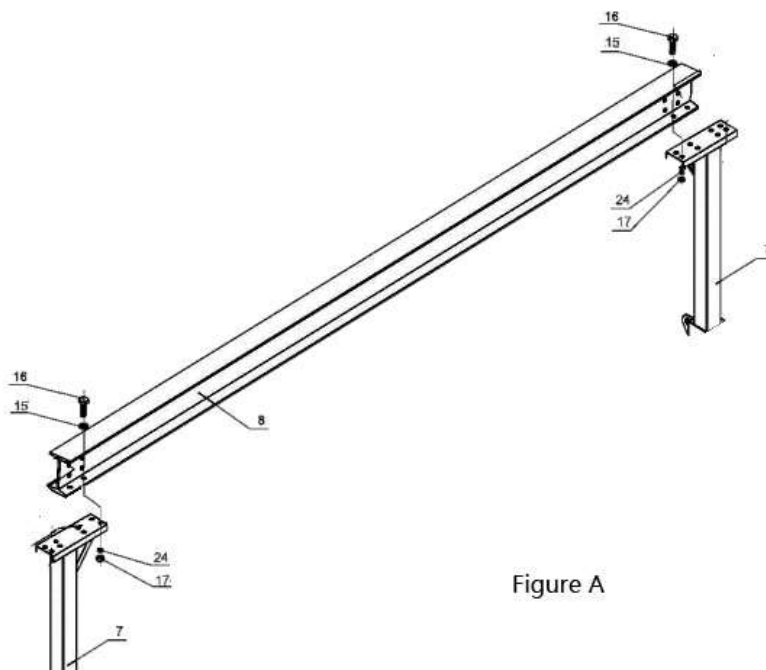

Figure A

Washers (15), Nuts (17), and Spring Washers (24).

6.Repeat for Right Connector Plate Assembly.

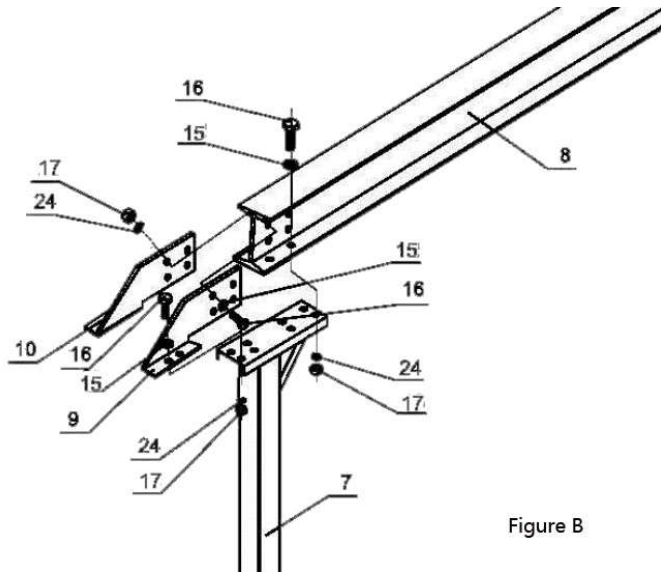

Figure B

Threaded
Shaft Size

Attaching Casters to Bases



(11) Nut M10 (12)



Spring Washer $\Phi 1$

(14) Bolt M10x30

1.Attach one Locking Swivel Caster (1) to one end of the Base (2) using four sets of Bolts (14), Spring Washers (13) and Nuts (11).

2.Repeat assemblies for the other three casters.

3.Tighten connections securely.

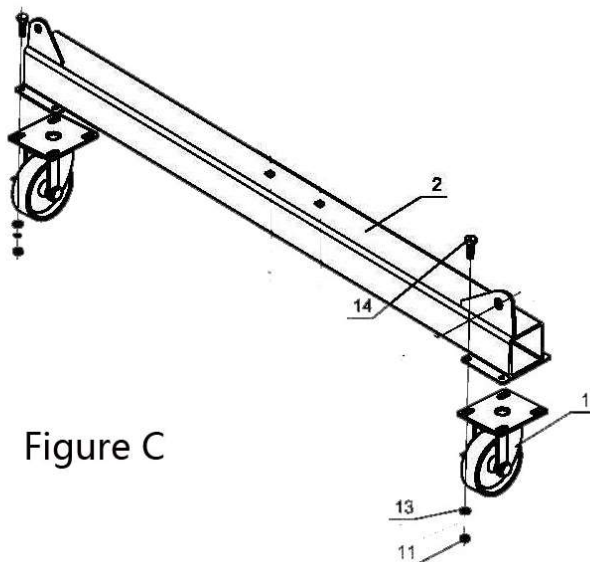
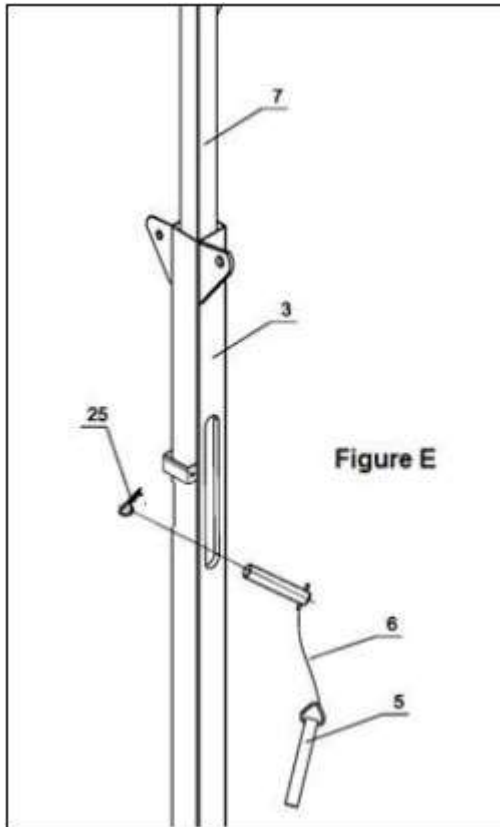

Figure C

4.Apply grease to each Caster bearing.

Attaching Post Insert to Post Sleeve

1. Place the Post Insert (7) into the Post Sleeve (3) connect with Insert Pin (5), then attach with R-Pin (25).



2. Repeat for the other side Post. Make sure to adjust the post to the some height.

Attaching Post Supports to Base and Post Sleeve



(20) Nut M16



(22) Washer $\Phi 16$



(36) Spring Washer $\Phi 16$



(21) Bolt M16 \times 40





Threaded
Shaft Size

(17) Nut M14 (15) Washer $\Phi 14$ (24) Spring Washer $\Phi 14$

(18) Bolt M14 \times 150

1. With assistance, lift the crane to the upright position.
2. Attach Post Sleeve (3) to Left Base (2) and assemble using Bolts (18), Washers (15), Spring Washers (24), and Nuts (17).
3. Attach Post Supports (4) to Left Base and Post Sleeve (3) using Bolts (21), Washers (22), Spring Washers (36) and Nuts (20).

4. Tighten connections securely.

5. Repeat for Right Base and Post Assemblies.

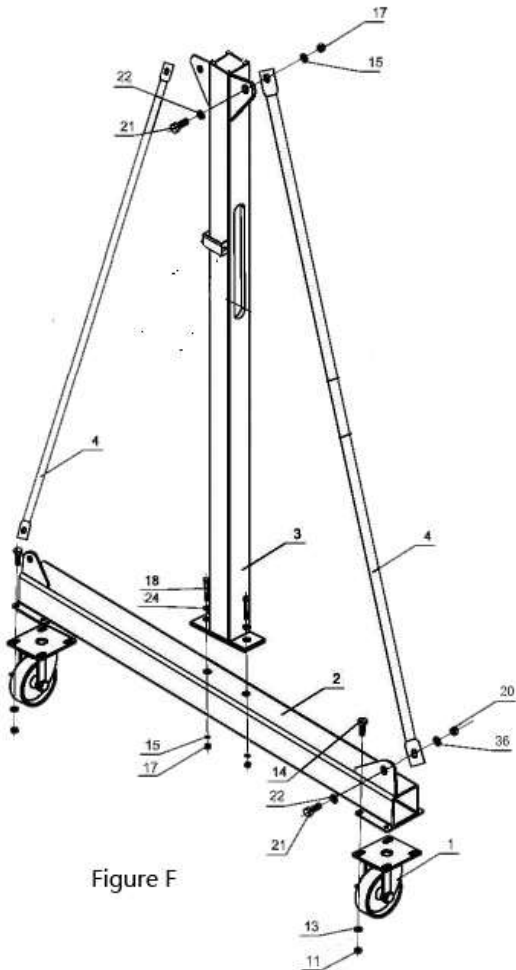
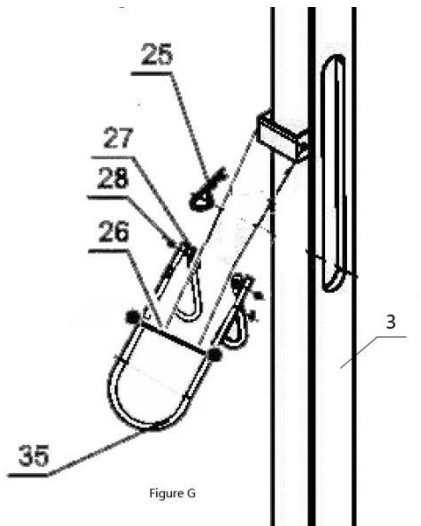

Figure F

Attaching Handles

The two handles are already installed.



Before Each Use

⚠ WARNING

- TO PREVENT SERIOUS INJURY AND DEATH: The use of gantry cranes is subject to certain hazards that cannot be met by mechanical means, but only by the exercise of intelligence, care, common sense, and experience in anticipating the motions that will occur as a result of operating the controls.
- Wear ANSI Z87.1 compliant safety goggles, hard hat, heavy-duty work gloves, and steel-toed work boots during operation.
- Do not use without Height Pins in place and secured with R-Pins.

Adjusting I-Beam Height

1. Make sure the hook (27) holds the insert pin A (5), and then press the handle (35) to lift.



2. With the handling remaining, insert the Pin B (5) to the hole beneath Pin A. Then the height will be locked in place .

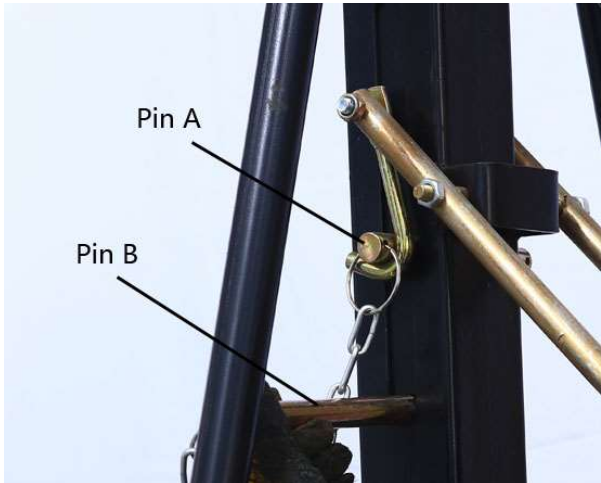

3. Put the hook(27) holds the insert pin B, and then pull out the pin A. Press the handles(35) to lift.

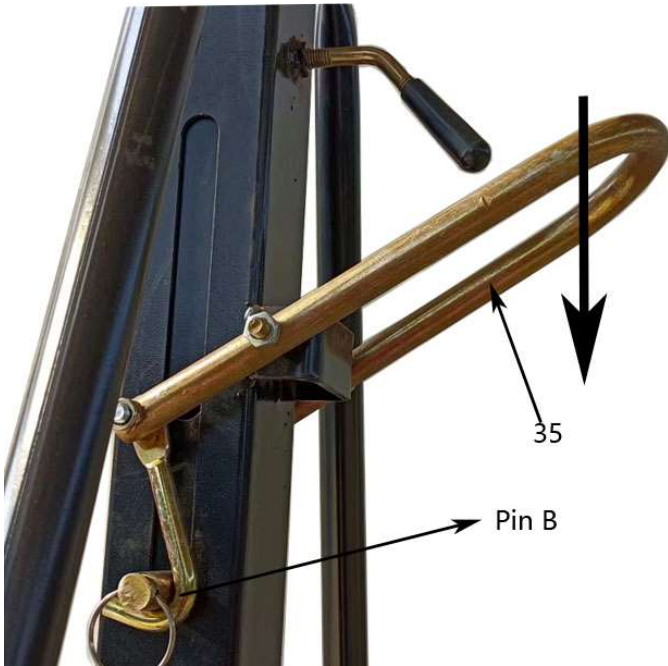

4.Repeat the procedure above until the desired height is achieved.

Before Operating Hoist

1. Familiarize yourself with all operating controls of the crane and with the operation(s) to be performed. Instructions include, the warnings on the crane, and the safety and operating instructions portion of this manual.

⚠WARNING

- **TO PREVENT SERIOUS INJURY FROM HOIST FAILURE:** Do not use damaged equipment. If adjustments or repairs are necessary, or any defects are known, have the problem corrected before further use.

2. Do not operate a crane with an out-of-order sign.
3. Only a qualified technician should perform maintenance to the crane.
4. Designate a work area that is clean and well-lit. The work area must not allow access by children or pets to prevent distraction and injury.
5. There must not be objects, such as utility lines, nearby that will present a hazard while working.
6. Lock casters before lifting a load.
7. Adjust I-Beam to horizontal level.

Operating Instructions

⚠ WARNING

- **TO PREVENT SERIOUS INJURY AND DEATH:** Use warning signs and barriers on the floor beneath the gantry crane where overhead maintenance work creates a hazard.
- Wear ANSI-approved safety goggles, hard hat, heavy-duty work gloves, and steel-toed work boots during operation.
- Always have a least 2 people operating crane at any time.
- Operate on a hard, level surface.
- Do not operate crane if the beam is not level.
- Do not use to lift people or animals.
- Keep persons and property clear from under the load.
- Do not allow the load to swing or roll against the support members.

Applying the Load

1. Attach the load to the load hook securely by properly rated, suitable means, such as chains, shackles, hooks, lifting slings, etc. Load must be attached to prevent accidental disconnection.

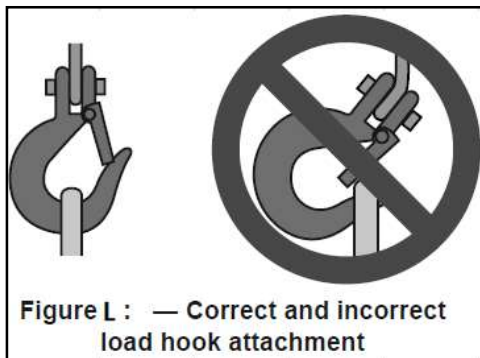

2. Properly seat the sling or other device in the base (bowl or saddle) of the hook (Figure L). Do not

allow the hook hitch to support any part of the load.

3. Do not apply the load to the point of the hook (Figure L).
4. Do not operate the crane unless the crane unit is centered over the load.
5. Do not pick up a load in excess of the rated load appearing on the crane or load block, except during properly authorized tests. Do not use a crane overload limiting device to measure the maximum load to be lifted.
6. Give specific attention to load balancing and hitching or slinging to prevent load slipping.

Moving the Load

1. Do not engage in any activity which will divert the operator's attention while operating the crane.
2. Respond to signals from a designated person only. Always obey a stop signal.
3. Do not lift or lower a load with the crane until the operator and all others are clear of the load.
4. Make sure the load and crane will clear all obstacles before moving or rotating the load.
5. Do not lift a load more than a few inches until it is well balanced in the sling or lifting device.
6. Each time a load approaching rated capacity is handled, check the crane brake action by lifting the load just clear of supports and continuing only after verifying that the brake system is operating properly.
7. Do not carry any load over any person.
8. Do not carry people on the hook or the load.
9. Avoid swinging the load or load hook when moving the crane.
10. Avoid contact between trolleys and between trolleys and stops.
11. Do not use the upper (or lower, if provided) limit devices as a normal means of stopping the crane. These are emergency devices only
12. Do not move the crane while loaded.

⚠WARNING

- Do not use to lift people or animals.
- Keep persons and property clear from under the load.
- Do not allow the load to swing or roll against the support members.
- Do not carry any load over any people.

Parking the Load

1. Do not leave a suspended load unattended unless specific precautions have been instituted and are in place.
2. Position the load block above head level for storage when the crane is not in use.
3. Exercise care when removing a sling from under a landed and blocked load.

After Each Use

1. Lock casters, adjust the crane at lowest height, insert Height Pins, and secure in place with R-Pins.
2. Position the load block above head level for storage when the crane is not in use.
3. Move the crane to a location where it will create the least interference with other cranes or object
4. Keep the crane in a place where is clean, well-lit.
5. To prevent injury, store in a place away from children and animals.

| |
|---|
| Maintenance |
| ⚠️ WARNING |
| <ul style="list-style-type: none"> • TO PREVENT SERIOUS INJURY FROM CRANE FAILURE: Do not use damaged equipment. If any defect or damage is noted, have the problem corrected before further use. • Repair or replacement of crane components must be performed only by a qualified technician using only identical replacement parts with the same rating. |

Maintain the product by adopting a program of conscientious repair and maintenance in accordance with the following recommended procedures. It is recommended that the general condition of any tool be examined before it is used. Keep your tool in good repair. Keep all cutting tools sharp and clean. Properly maintained cutting tools with sharp cutting edges are less likely to bind and are easier to control. Keep handles dry, clean, and free from oil and grease. The following chart is based on a normal operation schedule.

| | |
|-----------------------------|--------------------------|
| Maintenance Interval | Maintenance Point |
|-----------------------------|--------------------------|

| | |
|------------------------------------|---|
| <p>Daily before operating</p> | <ol style="list-style-type: none"> 1. Some components may require adjustment. The following are examples: <ol style="list-style-type: none"> A. Operating mechanisms B. Brakes 2. Note the following regarding specific components: <ol style="list-style-type: none"> A. Replace damaged or worn hooks. Do not repair them by welding or reshaping. B. Replace or repair all critical parts that are cracked, broken, bent, excessively worn, or missing. 3. Do not repair load-sustaining members by welding. Replace them as needed. 4. Lubrication: <ol style="list-style-type: none"> A. Immobilize gantry crane before lubrication by blocking casters. B. Lubricate all moving parts regularly using grease. 5. After maintenance work is completed and before restoring the crane to normal operation: <ol style="list-style-type: none"> A. Reinstall guards; Reactivate safety devices; B. Remove replaced parts and loose material; C. Remove maintenance equipment. |
| <p>Monthly Maintenance</p> | <ol style="list-style-type: none"> 1. Check operating mechanisms for proper operation, proper adjustment and unusual sounds. 2. Check upper limit device(s) of attached cranes, if equipped, according to manufacturer's documentation. 3. Check hooks and hook latches (if used), according to manufacturer's documentation. |
| <p>At Least Yearly Maintenance</p> | <ol style="list-style-type: none"> 1. Follow all Monthly Maintenance procedures. 2. Check for deformed, cracked, or corroded parts, replace them as needed. 3. Make sure all the parts as bolts, nuts, pins or rivets are fixed well. 4. Check for other worn, cracked, or distorted parts such as pins, bearings, wheels, shafts, gears, rollers, locking and clamping devices, bumpers, and stops. |

Troubleshooting

⚠ WARNING

- TO PREVENT SERIOUS INJURY FROM CRANE FAILURE: Do not use damaged equipment. If any defect or damage is noted, have the problem corrected before further use.
- Repair or replacement of crane components must be performed only by a qualified technician using only identical replacement parts with the same rating.

Use the table below to troubleshoot problems before contacting service personnel or your local dealer. If the problem continues after troubleshooting, call your local dealer for assistance.

| Failure | Possible Cause | Corrective Action |
|--|--|---|
| Crane doesn't move flexibly | Caster is locked | Loosen the caster brake |
| | Foreign objects stuck in caster | Remove the foreign objects from caster, and apply grease to each caster bearing |
| I-Beam (8) leans to one side, not standing at a horizontal level | Inspect Post Inserts (7) | Adjust two sides Post Insert (7) to same level hole |
| The handle doesn't move flexibly | Handle assembled incorrectly | Assemble the handle correctly |
| | Under heavily loading, the handle is not available | Press the handle under free loading. After raising, free the handle and insert with Pin (5) |

Parts Diagram

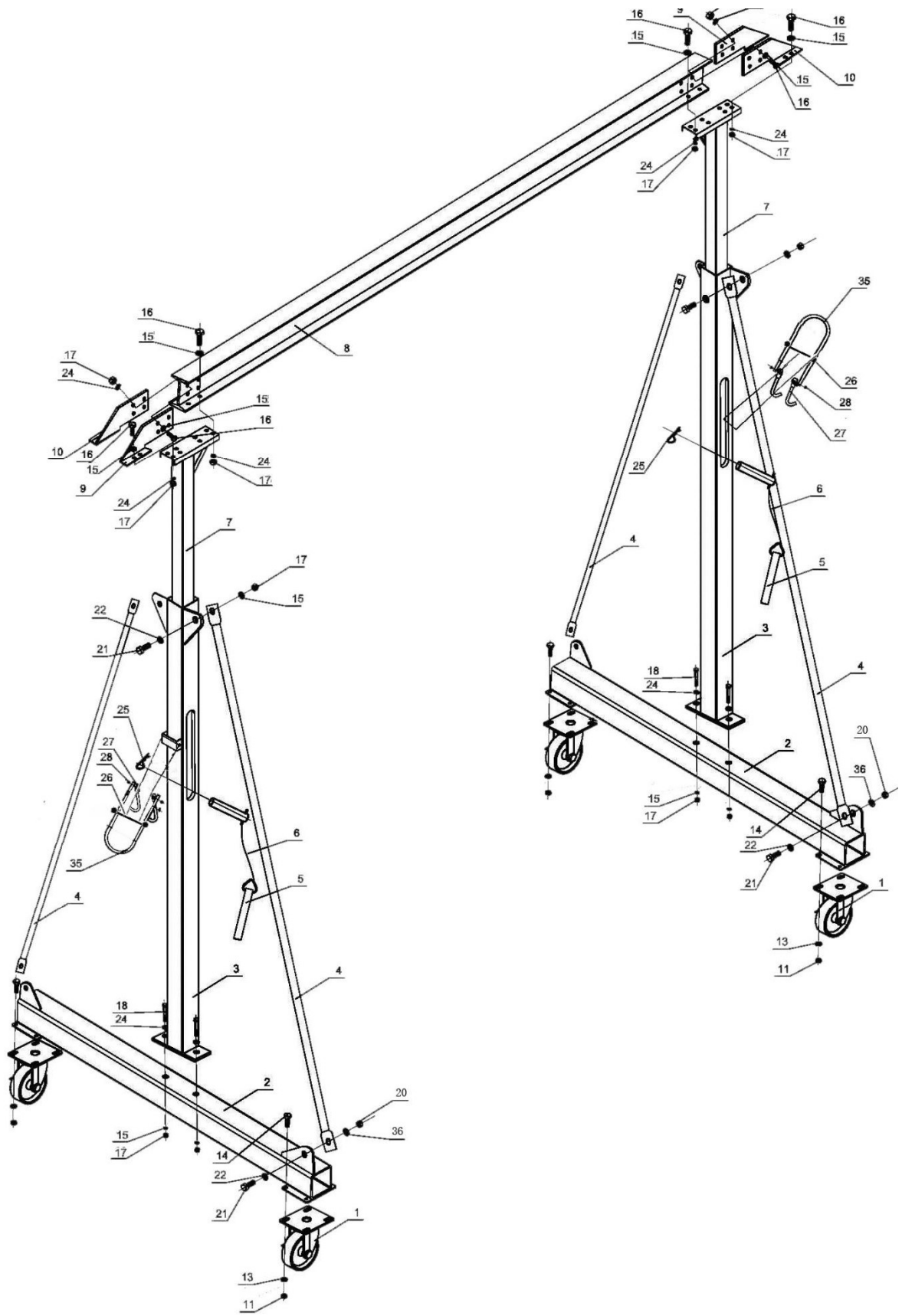

Parts List

| Part Number | Part Description | Quantity | Remark |
|-------------|--------------------------|----------|---------|
| 1 | 5" Locking Swivel Caster | 4 | |
| 2 | Base | 2 | |
| 3 | Post Sleeve | 2 | |
| 4 | Post Support | 4 | |
| 5 | Inserted Pin | 4 | |
| 6 | Cable | 2 | |
| 7 | Post Insert | 2 | |
| 8 | I-Beam | 1 | |
| 9 | Connector Plate A | 2 | |
| 10 | Connector Plate B | 2 | |
| 11 | Nut | 16 | M10 |
| 12 | ----- | ----- | ----- |
| 13 | Spring Washer | 16 | Φ10 |
| 14 | Bolt | 16 | M10×30 |
| 15 | Washer | 28 | Φ14 |
| 16 | Bolt | 28 | M14×40 |
| 17 | Nut | 28 | M14 |
| 18 | Bolt | 4 | M14×150 |
| 19 | ----- | ----- | ----- |
| 20 | Nut | 4 | M16 |
| 21 | Bolt | 8 | M16×40 |
| 22 | Washer | 8 | Φ16 |
| 23 | ----- | ----- | ----- |
| 24 | Spring Washer | 28 | Φ14 |
| 25 | R-Pin | 4 | |
| 26 | Bolt | 4 | M8×40 |
| 27 | Hook | 4 | |
| 28 | Nut | 4 | M8 |
| 29 | Spacer | 4 | |
| 30 | Connect Plate Spacer | 4 | |
| 31 | Spring | 4 | |
| 32 | Connector | 4 | |
| 33 | Washer | 12 | Φ8 |
| 34 | Safety Shaft | 6 | |
| 35 | Handle | 2 | |
| 36 | Washer | 8 | Φ16 |

Replacement Parts

- Not all product components are available for replacement. The illustrations provided are a convenient reference to the location and position of parts in the assembly sequence.
- When ordering parts, the following information will be required: item description, item model number, item serial number/item lot date code, and the replacement part reference number.

The distributor reserves the rights to make design changes and improvements to product lines and manuals without notice.

Limited Warranty

Northern Tool and Equipment Company, Inc. ("We" or "Us") warrants to the original purchaser only ("You" or "Your") that the Strongway product purchased will be free from material defects in both materials and workmanship, normal wear and tear excepted, for a period of **one year** from date of

purchase. The foregoing warranty is valid only if the installation and use of the product is strictly in accordance with product instructions. There are no other warranties, express or implied, including the warranty of merchantability or fitness for a particular purpose. If the product does not comply with this limited warranty, Your sole and exclusive remedy is that We will, at our sole option and within a commercially reasonable time, either replace the product or product component without charge to You or refund the purchase price (less shipping). This limited warranty is not transferable.

Limitations on the Warranty

This limited warranty does not cover: (a) normal wear and tear; (b) damage through abuse, neglect, misuse, or as a result of any accident or in any other manner; (c) damage from misapplication, overloading, or improper installation; (d) improper maintenance and repair; and (e) product alteration in any manner by anyone other than Us, with the sole exception of alterations made pursuant to product instructions and in a workmanlike manner.

Obligations of Purchaser

You must retain Your product purchase receipt to verify date of purchase and that You are the original purchaser. To make a warranty claim, contact Us at 1-800-222-5381, identify the product by make and model number, and follow the claim instructions that will be provided. The product and the purchase receipt must be provided to Us in order to process Your warranty claim. Any returned product that is replaced or refunded by Us becomes our property. You will be responsible for return shipping costs or costs related to Your return visit to a retail store.

Remedy Limits

Product replacement or a refund of the purchase price is Your sole remedy under this limited warranty or any other warranty related to the product. We shall not be liable for: service or labor charges or damage to Your property incurred in removing or replacing the product; any damages, including, without limitation, damages to tangible personal property or personal injury, related to Your improper use, installation, or maintenance of the product or product component; or any indirect, incidental or consequential damages of any kind for any reason.

Assumption of Risk

You acknowledge and agree that any use of the product for any purpose other than the specified use(s) stated in the product instructions is at Your own risk.

Governing Law

This limited warranty gives You specific legal rights, and You also may have other rights which vary from state to state. Some states do not allow limitations or exclusions on implied warranties or incidental or consequential damages, so the above limitations may not apply to You. This limited warranty is governed by the laws of the State of Minnesota, without regard to rules pertaining to conflicts of law. The state courts located in Dakota County, Minnesota shall have exclusive jurisdiction for any disputes relating to this warranty.



Distributed by:

Northern Tool & Equipment Company, Inc.

Burnsville, Minnesota 55306

www.northerntool.com

Made in China