

HOMEPLOW[®]
BY Meyer

OWNER'S MANUAL
AND
USER'S GUIDE



Read the Home Plow Owner's Manual before operating or servicing a snow plow.
FOLLOW THESE INSTRUCTIONS EXPLICITLY.

Thank You

Thank you for buying the Home Plow By Meyer. As a new owner of hard-working, mechanical equipment, we strongly urge you to spend quality time with this owner's manual. It's easy to use and full of time-saving tips that will enhance your ownership experience. It includes suggestions for faster installation, safe operation and more productive plowing.

We also strongly urge you to register your new Home Plow at thehomeplow.com. Registering will only take minutes and the benefits of doing so will last for years. When registered, you will receive timely and accurate communication on operation tips, maintenance, new products, and service bulletins. And in the unlikely event you need warranty work done, your local servicing dealer will be able to process your claim faster.

Thanks again for your business. You can now look forward to many years of reliable performance and keeping your driveway safer and easier to use. If you have any questions about your Home Plow, contact us at: www.thehomeplow.com

Sincerely,

Customer Service
Home Plow by Meyer
18513 Euclid Avenue
Cleveland, Ohio 44112
800-412-PLOW (7569)



Table of Contents

Subject	Page
Safety	2-3
Registration Data Sheet	4
Introduction	4
Snow Plow Assembly	5-11
Hook Up Plow	12
Disconnect Plow	13
How To Plow	14
Troubleshooting Guide	15
Pre-season & Post-season Maintenance	16-17
Auto Angling Parts Lists	18-20
Power Angling Parts List	21-23
Warranty	24

SAFETY DEFINITIONS



This is the safety alert symbol. It is used to alert you to potential personal injury hazards. Obey all safety messages that follow this symbol to avoid possible injury or death.

! DANGER

DANGER Indicates an imminently hazardous situation which, if not avoided, will result in death or serious injury.

! WARNING

WARNING Indicates a potentially hazardous situation which, if not avoided, could result in death or serious injury.















! CAUTION

CAUTION Indicates a potentially hazardous situation which, if not avoided, may result in minor or moderate injury.

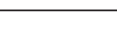
CAUTION

CAUTION used without the safety alert symbol indicates a potentially hazardous situation which, if not avoided, will result in property damage.

1	! DANGER	Never stand or ride on the plow assembly. Keep people and pets at least 25 feet away from the snow plow when in operation. Failure to comply will result in death or serious injury.
2	! DANGER	Insert and lock locking pin securely before using. Not doing so will result in serious injury or death. It can also result in damage to the vehicle and/or plow.
3	! WARNING	Always lower moldboard to the ground when snow plow is being serviced or when vehicle is not in use. Failure to comply could result in death or serious injury.
4	! WARNING	The Home Plow is for driveway plowing only and should be used on ½-ton and smaller vehicles. Use of this product on larger than ½-ton vehicles is prohibited and can result in damage to the vehicle or plow. Failure to comply could result in death or serious injury.
5	! WARNING	NEVER use the Home Plow without first CAREFULLY reading the Owner's Manual. It is CRITICAL for your safety to ALWAYS obey EVERY warning in the manual and follow EVERY instruction EXPLICITLY . Failure to comply could result in death or serious injury.
6	! WARNING	The Home Plow by Meyer should be used by drivers with a valid operator's license. Keep all body parts inside the vehicle. Failure to comply could result in death or serious injury.
7	! WARNING	To prevent accidental movement of the plow, always turn off the controller whenever the plow is not in use. Failure to comply could result in death or serious injury.
8	! WARNING	The Home Plow should NEVER be used for ANY other purpose other than plowing snow on a driveway, using The Home Plow for other purposes could result in serious injury or death.
9	! WARNING	Inspect plow assembly and mounting components and fasteners for wear and damage before and after each use. Worn or damaged components or fasteners could allow the plow to drop unexpectedly. Failure to comply could result in death or serious injury.
10	! WARNING	Do not change plow position while traveling. You could suddenly lower the plow accidentally. Failure to comply could result in death or serious injury.
11	! WARNING	ALWAYS wear a seat belt when plowing snow. Hidden obstructions can cause the vehicle to stop suddenly resulting in personal injury. Failure to comply could result in death or serious injury.
12	! WARNING	Do not mix different kinds of hydraulic fluid. Some fluids are not compatible and may cause performance problems and product damage Failure to comply could result in death or serious injury.
13	! WARNING	NEVER perform any repairs or maintenance with the plow controller turned on and the plow plugged into the vehicle harness and the plow attached to the vehicle. Failure to comply could result in death or serious injury.
14	! WARNING	The vehicle must not be operated when overloaded. In all cases, the loaded vehicle weight, including the entire snow plow system, all aftermarket accessories, driver, passenger, options, nominal fluid levels, and cargo must not exceed the front/rear Gross Axle Weight Rating (GAWR), and total Gross Vehicle Weight Rating (GVWR). These weights ratings are specified on the safety compliance certification label on the driver's side door opening. The use of rear ballast weight may be required to prevent exceeding the front GAWR. Failure to comply could result in death or serious injury.
15	! WARNING	Read the Home Plow Owner's Manual before operating or servicing a snow plow. FOLLOW THESE INSTRUCTIONS EXPLICITLY . Failure to comply could result in death or serious injury.
16	! WARNING	SAFETY PRECAUTIONS should be used when Hydraulic Unit is in OPERATION and plow is in a RAISED position. Lower plow to ground when vehicle is PARKED in case of hydraulic failure. Failure to comply could result in death or serious injury.

17		Remove Plow Assembly before placing vehicle on hoist/lift. Failure to comply could result in death or serious injury.
18		Do not exceed 10 mph transporting plow. Do not exceed 5 mph plowing snow. Know your road conditions at all times. Keep feet clear of moldboard at all times. Failure to comply could result in death or serious injury.
19		SAFETY PRECAUTIONS should be used when Hydraulic Unit is SERVICED. Hydraulic fluid under pressure can cause skin injection injury. If you are injured by hydraulic fluid, get medical attention immediately. Failure to comply could result in death or serious injury.
20		Vehicle exhaust contains lethal fumes. Breathing these fumes, even in low concentrations, can cause death. Never operate vehicle in an enclosed area without venting the exhaust to the outside. Failure to comply could result in death or serious injury.
21		Gasoline is highly flammable and gasoline vapor is explosive. Never smoke while working on vehicle. Keep all open flames away from gasoline tank and lines. Wipe up any spilled gasoline immediately. Failure to comply could result in death or serious injury.
22		Flag obstructions that are under snow to prevent damage to product or property. Failure to comply may result in minor or moderate injury.
23		A ballast weight may be required to prevent front GAWR overloading. If required, ballast must be securely attached at least 24 inches behind the rear axle. Failure to comply will result in property damage.
24		Batteries normally produce explosive gases which can cause personal injury. Therefore, do not allow flames, sparks or lit tobacco to come near the battery. When charging or working near a battery, always cover your face and protect your eyes, and also provide ventilation. Batteries contain sulfuric acid which burns skin, eyes and clothing. Failure to comply will result in property damage.
25		See your Home Plow Authorized Distributor/Web site for specific vehicle application recommendations before installation. Failure to comply will result in property damage.
26		Installation of a snow plow may affect your new vehicle warranty. For more information consult your Vehicle Owner's Manual / Vehicle Dealer. Failure to comply will result in property damage.
27		Warranty does not apply to a Home Plow product which has been negligently or improperly assembled or installed. Failure to comply will result in property damage.
28		CAUTION: To avoid harm to vehicles electrical system always disconnect battery before beginning installation. DO NOT BURN holes or WELD vehicle frame. This may cause frame failure. Failure to comply will result in property damage.
29		A driver's first responsibility is the safe operation of the vehicle and snow plow. The most important thing you can do to prevent a crash is to avoid distractions and pay attention to the road. Wait until it is safe to operate mobile communication equipment such as cell phones, two way radios, etc. Failure to comply will result in property damage.
30		Front end wheel alignment and headlight aim may require readjustment after installation of equipment, and is the responsibility of the equipment installer. Failure to adjust front wheel alignment may cause premature uneven tire wear. If required, reset to chassis manufacture's specifications. Failure to comply will result in property damage.

SAFETY DEFINITIONS



This is the safety alert symbol. It is used to alert you to potential personal injury hazards. Obey all safety messages that follow this symbol to avoid possible injury or death.



DANGER Indicates an imminently hazardous situation which, if not avoided, will result in death or serious injury.



WARNING Indicates a potentially hazardous situation which, if not avoided, could result in death or serious injury.



CAUTION Indicates an potentially hazardous situation which, if not avoided, may result in minor or moderate injury.



CAUTION used without the safety alert symbol indicates a potentially hazardous situation which, if not avoided, will result in property damage.

Introduction

The Home Plow has published this manual to help you get maximum performance from your snow plow and familiarize you with the features designed for efficiency and safety; be sure you recognize and understand them. Follow recommended operation and maintenance instructions, so when the storm hits, your Home Plow will be ready and you will know how to plow like a pro. **WARNING: Deployment of an air bag while using a The Home Plow will not be covered under The Home Plow's warranty.**

In conjunction with FMVSS (Federal Motor Vehicle Safety Standards) and OEM (Original Equipment Manufacturer) guidelines, The Home Plow has designed this plow pack.

We also strongly urge you to register your new Home Plow at thehomeplow.com. Registering will only take minutes and the benefits of doing so will last for years. When registered, you will receive timely and accurate communication on operation tips, maintenance, new products, and service bulletins. And in the unlikely event you need warranty work done, your local servicing dealer will be able to process your claim faster.

Vehicle requirements: Two or Four wheel drive SUV/Pick-up type vehicle 1/2 ton or smaller including Utility Vehicles. Use on vehicles greater than 1/2 ton is prohibited. Minimum 60 Amp alternator. Minimum 70 Amp Battery (550CCA/Cold Cranking Amps). Must be able to accept a front 2" category 3 receiver hitch. Front suspension must be able to handle 250 lbs. of added weight of plow and hitch. Stock vehicle with no suspension modifications (lift kits) that have modified the height of the vehicle.

Hitch Requirements: Category 3 2"x2" front receiver. 300lb. Tongue weight rating – 3000lb. pull rating

THE HOME PLOW HYDRAULIC SYSTEM HAS BEEN SHIPPED DRY. FILL ONLY WITH MEYER M-1 HYDRAULIC FLUID. SEE PAGE 6 FOR DETAILS.

Under the continuing Home Plow Improvement Plan, The Home Plow reserves the right to change design details and construction without prior notice and without incurring any obligation.

Registration Data Sheet

Register your snow plow at www.thehomeplow.com

Owner Name _____

Address _____

City _____

State/Province _____ Zip/Postal Code _____

Purchased From Company Name _____

Contact Name _____

Address _____

City _____

State/Province _____ Zip/Postal Code _____

Phone Number (_____) _____

E-mail _____

Date Purchased _____

Vehicle Make _____ Vehicle Model _____

Vehicle Year _____ Vehicle VIN _____

Controller Serial Number _____

Moldboard Serial number _____

Manufacturer of Hitch Mount _____

Snow Plow Assembly

Your new Home Plow System consist of two cartons, Plow Carton and Hydraulic Lift Frame Carton.

Plow Carton

Hydraulic Lift Frame Carton



Recommended assembly tools:



1/2" drive ratchet with 15/16" deep well socket

side cutters



15/16" combination wrench

1/2" combination wrench



8 or 10mm combination wrench
dependant on vehicle manufacturer

12mm combination wrench

Carton contains:

1. Plow Assembly
2. Hydraulic Assembly
3. Auto or Power Angling Ram
4. Hydraulic Cover
5. Plow Parts Bag (08258 pg. 18 or 08263 pg. 21)
6. Mounting Hardware Bag (08245 pg. 18 or 08264 pg. 21)
7. Hydraulic Fluid (2 quarts)
8. Dielectric Grease

Items not shown above:

- Controller
- Vehicle Harness
- Vehicle Harness Extension
- Zip Ties
- Plow Marker
- Hitch Mount (*sold separately*)

SAFETY PRECAUTIONS - See pages 2-3 for definitions

⚠ DANGER

⚠ CAUTION 27, 28

⚠ WARNING 12

STEP 1: PLOW & HYDRAULIC LIFT FRAME ASSEMBLY

STEP 1a

Connect Plow Assembly to Hydraulic Assembly (fig. 1) using 5/8-11 x 5" Bolt (fig. 2) and 5/8-11 Locknut (fig. 3) from the Mounting Hardware Bag.

STEP 1b

Attach the two wheel assemblies with the shorter brackets to either side of the plow pivot bar (fig. 4 & 5) and the third wheel assembly to the Hydraulic Assembly A-frame under the lifting cylinder using three Hair Pin Cotter (fig. 6) from the Mounting Hardware Bag.

STEP 1c

Attach the Auto or Power Angling Ram to the A-Frame using two 1/2 x 3" Pivot Pins (fig. 7), six 1/2" Flatwashers and two 1/8" x 1-5/16" Hair Pins (fig. 8). Be sure four 1/2" washers are positioned as shown in figure 8 and remaining two 1/2" washers are placed over the 1/2" x 3" Pivot Pins before the two 1/8" x 1-5/16" Hair Pins are installed. Figure 9 shows the proper set-up with the Power Angling Ram.

STEP 1d

Remove Reservoir Cap from Hydraulic unit (fig. 10) and fill with Meyer M-1 Fluid (fig. 11) Provided up to the full mark located on the reservoir. Re-install Reservoir Cap.

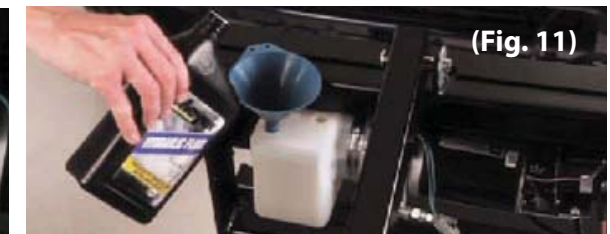
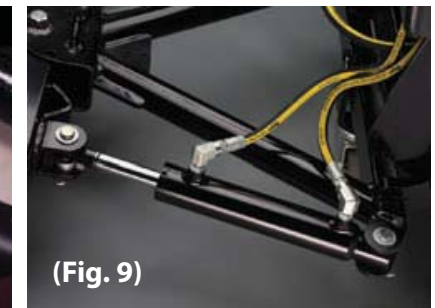
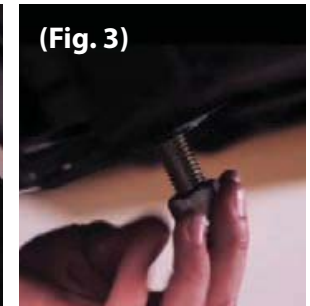
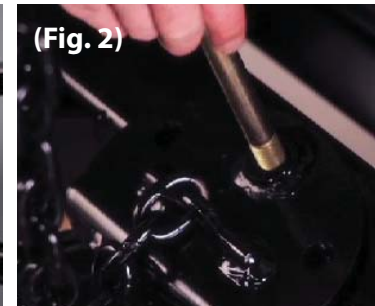
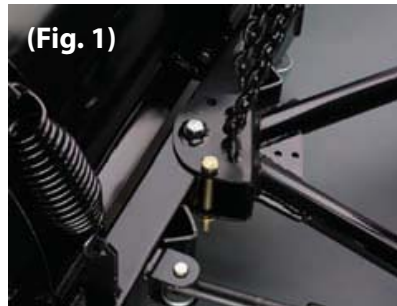

STEP 1e

Install Plow Markers to each side of plow using 5/16-18 x 1" bolt, 5/16 flatwashers and 5/16-18 locknut as shown below.



Your Home Plow System should now look like the picture below.



STEP 2: WIRING INSTALLATION

STEP 2a

Carefully route the Vehicle Harness to the vehicle battery (fig. 12). You may need to route thru the grille or behind/under the bumper. Be sure to stay away from hot, sharp or moving parts of the vehicle and use the zip ties provided to secure. Attach the Black wire to the negative (-) battery post (fig. 13) and the red wire to the positive (+) battery post (fig. 14).

STEP 2b

Carefully attach the Vehicle Harness Extension to the vehicle harness (fig. 15) and route extension into the vehicle. The extension can either be routed thru the firewall (fig. 16) or along the hood channel (fig. 17) and thru the window or door jamb (fig. 18). Be sure to stay away from hot, sharp or moving parts of the vehicle and use the zip ties provided to secure. **If routing thru window or door make sure the hood, door or window closes without pinching or cutting the harness.** Connect the Controller to the Harness Extension (fig. 19).

STEP 2c

Install your Receiver Hitch Mount (sold separately, see hitch requirements on pg. 4) per manufacturers instructions. Measure center of square hitch to the ground. This dimension (A) should be a minimum of 11" and a maximum of 14" (fig. 20). Measure from the hitch pin hole to the very end of your bumper. This dimension (B) should be not more than 8-1/2" (fig. 20). If your dimension does not fall within these ranges you should contact your hitch dealer/manufacturer for height or length adjustment accessories.

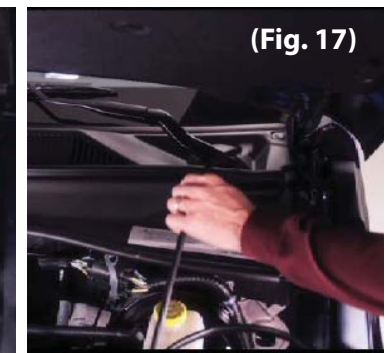
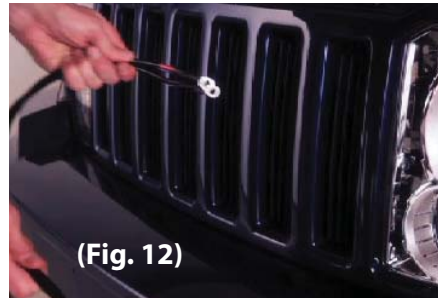

STEP 3: INSTALL PLOW ONTO VEHICLE

(Fig. 21)

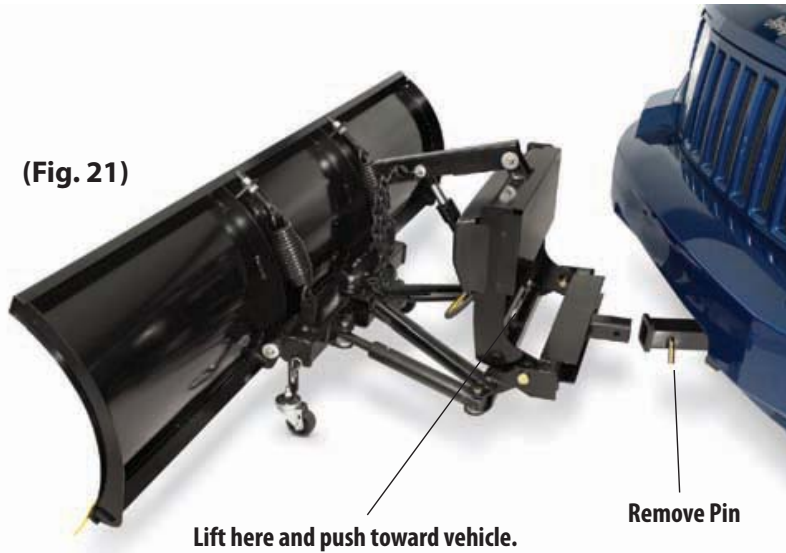

(Fig. 22)



(Fig. 23)

STEP 3a

Gently roll the plow to the receiver hitch on the vehicle so that the male tube on the lift frame is lined up directly in front of the receiver hitch (fig. 21). Lift slightly on the "Lift Here" decal (fig. 22) and push plow assembly into the vehicle receiver hitch until the pin holes align (fig. 23). Proper install is shown in Figure 24.



(Fig. 24)

STEP 3b

Remove both weather covers from the ends of the Plow Harness and Vehicle Harness, add dielectric grease to the connecting prongs and connect.



STEP 3c

Turn on Controller.



Auto Angling Controller (Part #22826)

Power Angling Controller (Part #22827)



Auto Angling Controller Operation

(Part #22826): Turn the controller on. When turned on the controller will illuminate. The Plow UP and Plow DOWN switch is a 3 position switch. The plow can be raised “up” by pressing on the top half of the Plow Up/Plow Down switch. Once released, the switch will return to the center position. The plow can be lowered by pressing the bottom half of the Plow Up/Plow Down switch. This will stay in the Down or “Float” position until the operator pushes the switch to the center position or raise “Plow UP” position. When the switch is in the Down or “Float” position it will keep the S1 valve energized which will allow the plow to remain in contact with the ground regardless of grade. When the switch is in the center position it will not allow the plow to lower automatically when encountering a different grade. Make sure controller is turned off when plow is not in use.

Power Angling Controller Operation

(Part #22827): Turn the controller on by holding down the on/off switch until the controller lights up (1 second). To raise the plow press the up arrow. To angle the plow left press the left arrow and to angle the plow right press the right arrow. The plow can be lowered by pressing the lower (down) arrow. If the lower button is pressed for more than 1 second the plow will go into “Float”. “Float” position will keep the S1 valve energized which will allow the plow to remain in contact with the ground regardless of grade. Pressing the raise arrow will take the plow out of Float and will not allow the plow to lower automatically when encountering a different grade. The controller has timers built in for safety. The plow will only raise continually for 4 seconds at a time and angle left or right continually for 6 seconds at a time. The controller will automatically shut down the function being used if the timer values (4 seconds for raise and 6 seconds for angle) are exceeded. In order to reset simply release the function being pressed and this will reset the timer and controller. Make sure controller is turned off when plow is not in use.

STEP 3d

Raise plow and reposition the two front wheel brackets 180 degrees (fig. 25) and the one rear wheel bracket 90 degrees (fig. 26) for plowing mode.

STEP 3e

Raise and lower (and angle left & right if equipped with power angling) plow 10 times to automatically purge the air out of the hydraulic system. Lower plow to ground and turn off controller. Check fluid level in hydraulic unit (fig. 27) and top off if necessary (fig. 28)(see step 1d). Attach Hydraulic Cover to Hydraulic Assembly Lift Frame using two Cover fasteners on each side (fig. 29). (The cover fasteners are locked in place when the center nail of the cover fastener is pushed in)



ATTACH PLOW TO VEHICLE

Remove Hitch Pin. Gently roll the plow to the receiver hitch on the vehicle so that the male tube on the lift frame is lined up directly in front of the receiver hitch (fig. 30). Lift slightly on the "Lift Here" decal (fig. 31) and push plow assembly into the vehicle receiver hitch until the pin holes align (fig. 32). Proper install is shown in Figure 34. Connect electrical plug (fig. 33) and raise plow to turn all three plow wheels to the plowing position (fig 35 & 36).

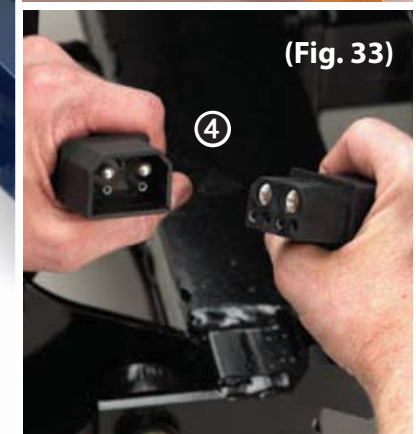
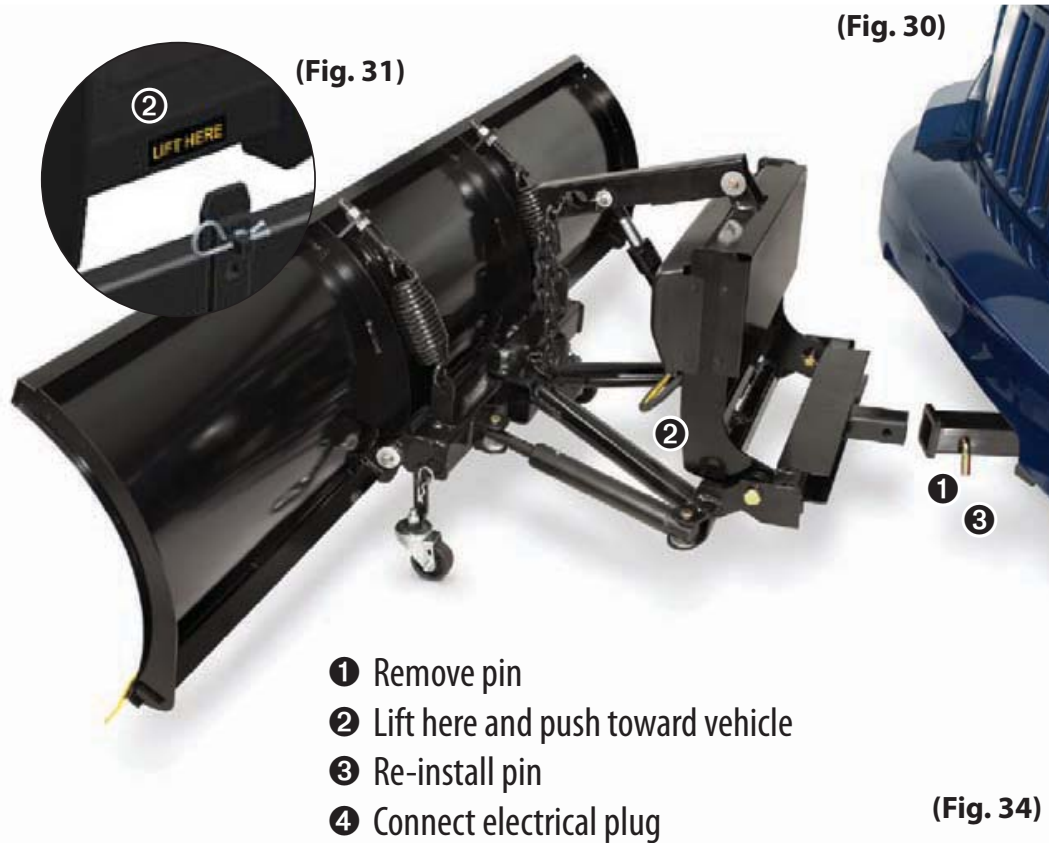

- 1 Remove pin
- 2 Lift here and push toward vehicle
- 3 Re-install pin
- 4 Connect electrical plug

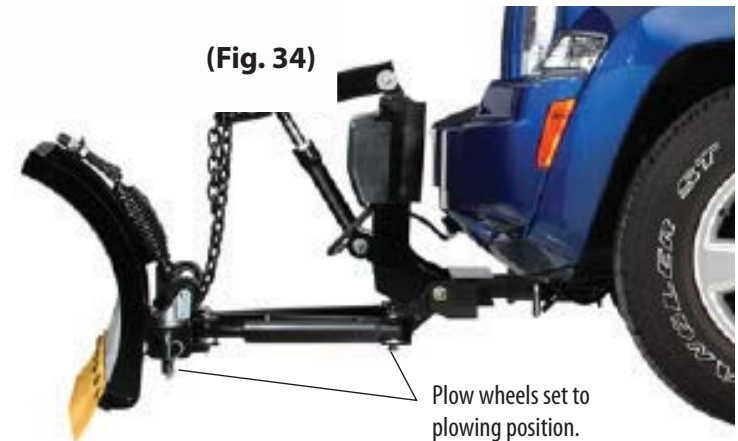
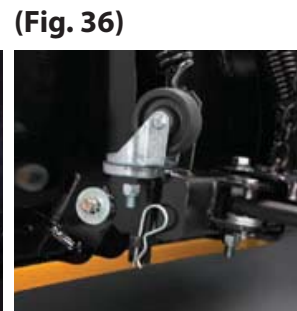

REMOVE PLOW FROM VEHICLE

Raise plow and set wheels to storage position (fig. 37-39). Lower plow into "Float" position and push down on lift arm to put slack into the lift chain (fig. 40). Disconnect electrical plug (fig. 41) and install weather covers to both end of the harness. Remove Hitch pin (fig. 40). Gently lift at "Lift Here" decal (fig. 42) and slide Lift Frame out of receiver hitch on vehicle (fig. 43). Re-install Hitch pin thru Lift Frame.



(Fig. 37)

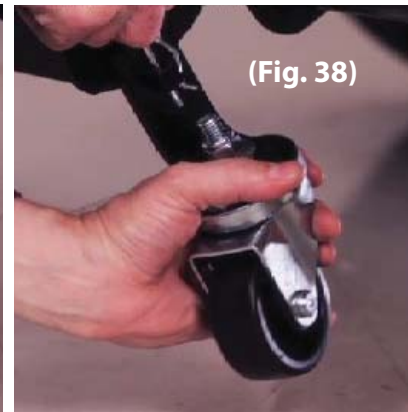

(Fig. 38)



(Fig. 39)

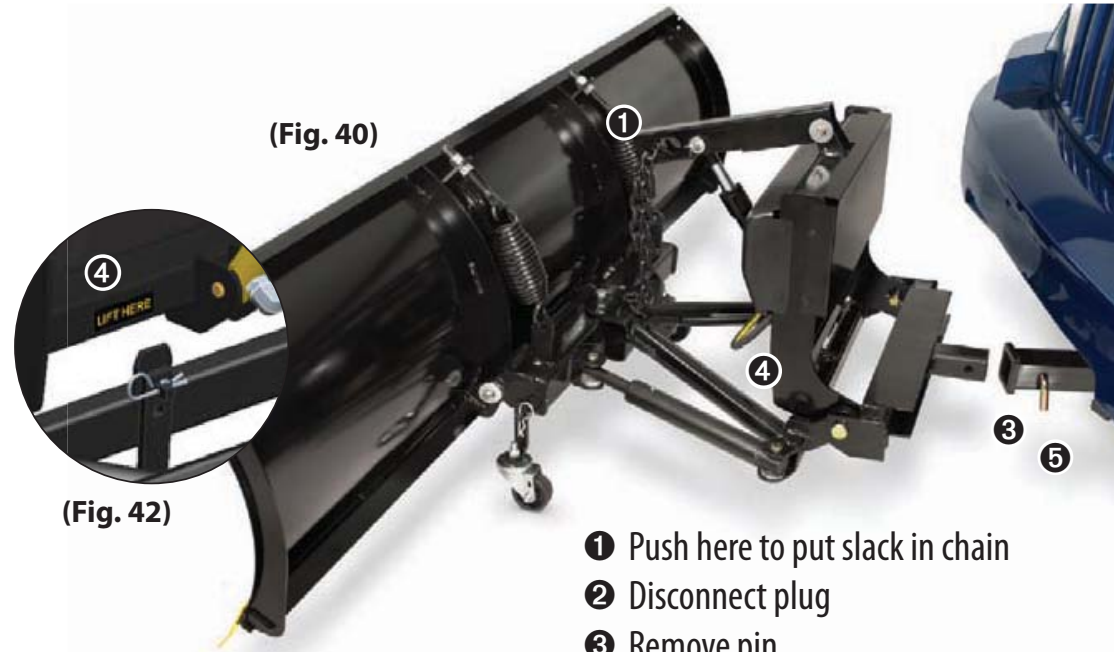

(Fig. 40)



(Fig. 42)



(Fig. 41)



(Fig. 43)

- ① Push here to put slack in chain
- ② Disconnect plug
- ③ Remove pin
- ④ Lift here and pull away from vehicle
- ⑤ Replace pin to plow hitch

HOW TO PLOW

Chain Adjustment

The chain is adjustable at the lift arm. The chain must be adjusted with the controller in the down (Float) position and the lift cylinder must be pushed down as far as it will go. The chain should be adjusted to have 2-3 links of slack (fig.44). Also if a major hydraulic malfunction is experienced the plow can be raised by a floor jack or two people and the chain can be adjusted up with no slack. This will then suspend the plow above ground so the vehicle can be driven to your nearest Home Plow Service center.

Plowing (with Auto Angling)

Always plow with the storm, every 2-3" of accumulation. The Auto Angling Plow will raise and lower the plow from inside the comfort of your vehicle and allows the plow to automatically angle to the side with the heaviest amount of snow and when raised the plow will automatically return to the center or straight position (fig. 45). The plow also is equipped with a fixed angle pin (fig. 46) which can position the plow to the left or right. To use the fixed angle pin manually push the plow to the left or right and drop in the fixed angle pin and secure with the hair pin. Lift as high as possible, then drive through the snow to the garage. Drop the blade and back drag away from the garage. Turn around, back into the cleared path to the garage, set the blade in an angled position if necessary and continue rolling snow away from the house. Complete as many passes as necessary to clear the snow. The first storm of the season, plow back from the drive area to allow space to pile future snowfall.

Plowing (with Power Angling)

Always plow with the storm, every 2-3" of accumulation. The Power Angling Plow will raise, lower, angle left and angle right from inside the comfort of your vehicle (fig. 47). Enter the driveway rolling snow away from the residence. Stop about two-thirds of the way in, set the blade in angled position, lift as high as possible, then drive through the snow to the garage. Drop the blade and back drag away from the garage. Turn around, back into the cleared path to the garage, reset the blade angle and continue rolling snow away from the house. Complete as many passes as necessary to clear the snow. The first storm of the season, plow back from the drive area to allow space to pile future snowfall.



(Fig. 44)



(Fig. 45)



(Fig. 46)



(Fig. 47)

Troubleshooting Guide for The Home Plow Auto Angling

CONDITION	POSSIBLE CAUSE	CORRECTION
Plow doesn't lift or lifts slowly – motor operates	<ol style="list-style-type: none"> 1. Low hydraulic fluid level. 2. Discharged battery. 3. Leaking or open "S1" cartridge. 4. Malfunctioning Hydraulic Unit. 	<ol style="list-style-type: none"> 1. Add fluid to proper level 2. Recharge battery. 3. Clean or replace "S1" cartridge. 4. Replace Hydraulic Unit.
Motor doesn't operate	<ol style="list-style-type: none"> 1. No current to Motor Solenoid (<i>small red wire</i>) 2. Small purple wire not grounded 3. Malfunctioning Motor Solenoid 4. Malfunctioning motor 5. Malfunctioning Hydraulic Unit 	<ol style="list-style-type: none"> 1. Locate malfunction and repair. (<i>Check controller</i>) 2. Ground small purple wire 3. Replace motor Solenoid 4. Replace motor 5. Replace Hydraulic Unit
Plow doesn't lower	<ol style="list-style-type: none"> 1. No current to "S1" coil. (<i>white and black with white stripe wires</i>) 2. "S1" cartridge jammed in closed position. 3. Inoperative "S1" coil. (<i>black with white stripe & white wire</i>) 	<ol style="list-style-type: none"> 1. Locate malfunction and repair. (<i>Check controller</i>) 2. Replace "S1" cartridge. 3. Replace "S1" coil. (<i>black with white stripe & white wire</i>)
Plow creeps down	<ol style="list-style-type: none"> 1. Leaking "S1" cartridge. 2. Leaking Raise Cylinder. 	<ol style="list-style-type: none"> 1. Clean or replace "S1" cartridge. 2. Replace Raise Cylinder.

"X" are the energized items.

	Motor Solenoid	S1
Raise	X	
Lower		X

"X" are the energized items.

	Motor Solenoid	S1	S2
Raise	X (T1)		
Lower		X	
Left	X (T2)		X
Right	X (T1)		X

Troubleshooting Guide for The Home Plow Power Angling

CONDITION	POSSIBLE CAUSE	CORRECTION
Plow does not lift or lifts slowly – motor operates	<ol style="list-style-type: none"> 1. Low hydraulic fluid level. 2. Discharged battery. 3. Leaking or open "S1" cartridge. 4. Motor turning counter clockwise 5. Malfunctioning Hydraulic Unit. 	<ol style="list-style-type: none"> 1. Add fluid to proper level 2. Recharge battery. 3. Clean or replace "S1" cartridge. 4. Check wiring to motor solenoid (<i>T1 should be energized</i>) – Check Controller – Replace motor solenoid. 5. Replace Hydraulic Unit.
Plow Angles Right when Raise switch is pressed	<ol style="list-style-type: none"> 1. Leaking or open "S2" cartridge. 2. Wiring not correct 3. Bad Controller 	<ol style="list-style-type: none"> 1. Clean or replace "S2" cartridge. 2. Check wiring harness 3. Replace Controller
Motor doesn't operate	<ol style="list-style-type: none"> 1. Check red and black wires at battery. 2. No current to Motor Solenoid. (<i>small red wire T1 & small black wire T2</i>) 3. Malfunctioning Motor Solenoid 4. Malfunctioning motor. 5. Malfunctioning Hydraulic Unit. 	<ol style="list-style-type: none"> 1. Clean and tighten connection 2. Locate malfunction and repair. (<i>Check controller</i>) 3. Replace motor Solenoid 4. Replace motor. 5. Replace Hydraulic Unit.
Plow doesn't lower	<ol style="list-style-type: none"> 1. No current to "S1" coil. (<i>black with white stripe & white wire</i>) 2. "S1" cartridge jammed in closed position. 3. Inoperative "S1" coil. (<i>black with white stripe & white wire</i>) 	<ol style="list-style-type: none"> 1. Locate malfunction and repair. (<i>Check controller</i>) 2. Replace "S1" cartridge. 3. Replace "S1" coil. (<i>black with white stripe & white wire</i>)
Plow creeps down	<ol style="list-style-type: none"> 1. Leaking "S1" cartridge. 2. Leaking Raise Cylinder, hose or fitting. 	<ol style="list-style-type: none"> 1. Clean or replace "S1" cartridge. 2. Replace Raise Cylinder or hose.
Plow does not angle Left	<ol style="list-style-type: none"> 1. No current to "S2" coil. (<i>orange and black w/white stripe wire</i>) 2. Motor tuning clockwise. 3. Bad "S2" valve. 	<ol style="list-style-type: none"> 1. Locate malfunction and repair. (<i>orange & black w/white stripe wire</i>) 2. Check wiring of motor solenoid. (<i>T2 should be energized</i>) – Check Controller – Replace motor solenoid. 3. Replace "S2" valve.
Plow does not angle Right	<ol style="list-style-type: none"> 1. No current to "S2" coil. (<i>orange and black w/white stripe wire</i>) 2. Motor tuning counter clockwise. 3. Bad "S2" valve. 	<ol style="list-style-type: none"> 1. Locate malfunction and repair. (<i>orange & black w/white stripe wire</i>) 2. Check wiring of motor solenoid. (<i>T1 should be energized</i>) – Check Controller – Replace motor solenoid. 3. Replace "S2" valve.

Pre-season & Post-season Maintenance

The Home Plow recommends this maintenance information for regular service. Sustained heavy operation may call for more frequent service. Snow plowing subjects a vehicle to exceptionally rugged use. As a result, it is very important to inspect and maintain the snow plow and vehicle up to maximum operating conditions. **Inspection should be made of both the vehicle and snow plow prior to the plowing season and after each use.**

PRE-SEASON MAINTENANCE Scheduled vehicle maintenance should be performed as recommended by the manufacturer.

Don't forget that in addition to keeping equipment in order:

1. Keep windshield wipers, heaters and lights working.
2. Use emergency flasher lights for increased visibility and safety.
3. Equip vehicles with chains where necessary.

VEHICLE ELECTRICAL SYSTEM For maximum efficiency, the vehicle supporting the snow plow must be properly serviced. The system should consist of at least a 70 amp./hr. battery and a 60 amp alternator. Be sure to check regularly:

1. Battery terminals to assure they're clean and free of corrosion.
2. Electrical connections, to assure they're tight and corrosion free.
3. Battery must be in top operating condition.
4. Alternator and regulator, to assure maximum electrical output.

Check the Diagnosis chart Pre/Post Season Maintenance for advice on maintaining the unit.

1. ALWAYS LOWER MOLDBOARD TO THE GROUND WHEN SNOW PLOW IS BEING SERVICED OR WHEN VEHICLE IS NOT IN USE.

2. Check and maintain hydraulic fluid reservoir level to Full. Oil level should be checked with lift ram down or retracted position.

3. Check entire hydraulic system for leaks. A significant drop in hydraulic fluid level is evidence of a leak which must be corrected to prevent serious damage.

4. Before and after each season, Grease all pins and lubricate all pivot points with chassis lube.

5. CUTTING EDGE – Replace the cutting edge as soon as it is 3-1/2" (5" is new) Tall. This will prevent permanent damage to the moldboard (fig. 48).

6. ADJUSTING TRIP SPRING TENSION – Tighten top locknut 4 turns beyond the point when spring coils begin to separate. Tighten bottom locknut to hold eye bolt in position (fig. 49).

7. MOUNTING BOLTS – Retighten all mounting bolts after first snow plowing session and at regular intervals through the season.

8. SNO-FLO® POWDER COATING, both black and yellow, should be checked at the beginning and end of each season for any signs of rust.

If any exists, use Sno-Flo® powder coat touch-up available in spray cans.

NOTE: PROTECTION AGAINST RUST AND CORROSION When the power unit is not used for extended periods, **protect the chromed lift rod by fully extending and coating it with chassis lubricant.** Coat the exposed portions of the power angling cylinder rods with chassis lubricant to protect against corrosion.



(Fig. 48)



(Fig. 49)

POST-SEASON SUMMER MAINTENANCE

1. Draining & Replacing The Home Plow Meyer M-1 Hydraulic Fluid Drain the fluid by un-bolting the hydraulic unit from the Lift Frame and removing the Reservoir Breather. Turn the hydraulic unit upside down and drain the fluid from the reservoir. To drain the fluid from the power angling cylinders(if equipped), disconnect the fittings and completely retract the cylinder rods and purge cylinder and hose of all hydraulic fluid. The complete system should then be flushed out with Meyer M-2 Flushing Fluid before adding new Meyer Hydraulic Fluid. To flush the unit, re-install the hydraulic unit to the Lift Frame and hose to the angle cylinder (if equipped). Add 1 quart of M-2 Flushing Fluid to the reservoir and replace the Reservoir Breather. Cycle the unit Up, Down, Left and Right 5 times in each direction. Then drain the hydraulic unit as before and re-fill with Meyer M-1 Fluid. Check fluid level after cycling plow and top off if necessary.

2. Meyer M-1 Hydraulic Fluid is specially formulated with an anti-ice additive for almost constant viscosity in subzero temperatures. Because it is free-flowing in extreme cold, the unit's performance and efficiency are not affected by winter weather. It is effective for a maximum of one year. Always carry an extra quart of **Meyer M-1 Hydraulic Fluid**. Use of any inferior fluids will void The Home Plow warranty.

SNOW PLOW STORAGE

1. When snow plow is disconnected, **disconnect lift chain from lift arm and extend lift cylinder to end of stroke and coat chrome rod with light grease.** This fills the cylinder with hydraulic fluid and protects the interior and exterior from rust and corrosion.

2. Whenever Moldboard is disconnected, coat the exposed portions of the power angling cylinder chrome rod (if equipped) with light grease to protect it from corrosion.

3. Coat pivot pin and other wear points with chassis lubricant. Be sure to grease all grease holes.

4. Unplug electrical connection. Coat connection with a dielectric compound to prevent corrosion and plug into their corresponding weather plug.

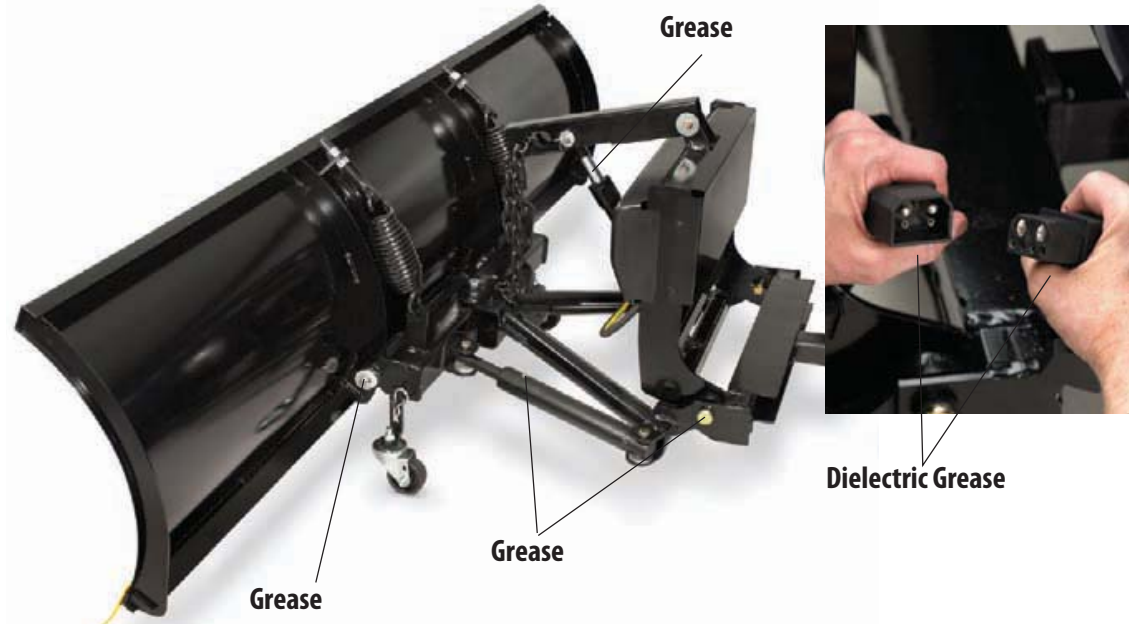

Available at www.thehomeplow.com



Meyer M1 Hydraulic oil and Flush is scientifically formulated to withstand extreme winter temps up to -40F.



Protects your electrical system with Meyer winter formula dielectric grease.



Yellow and black paint is formulated to withstand harsh temperatures and the winter environment.

PARTS LIST

HOME PLOW AUTO ANGLING

ITEM	PART NO.	QTY.	DESCRIPTION
	25000		Home Plow Auto Angling
	16609	1	• Home Plow PAF/Lift Frame Auto Angling
	13145	1	•• Lift Frame & Hydraulic Assy
1	13095	1	••• A-Frame
2	13129	1	••• Rear Cover
3	13130	1	••• Lift Frame
4	13142	1	••• Lift Arm
5	20027	2	••• Bolt 5/16-18 x 1" Gr. 2
6	20326	2	••• Lockwasher 5/16"
7	20352	2	••• Flatwasher 5/16"
8	20355	3	••• Flatwasher 1/2"
9	20420	2	••• Cotter Pin 1/4" x 2"
10	22436	2	••• Pin 1" x 3"
11	22816	3	••• Pivot Pin 1/2" x 3"
12	22821	4	••• Cover Fastener
13	22845	3	••• Hair Pin 1/8" x 1- 5/16"
14	09917	1	••• Plow Marker Kit
15	13853	1	••• Auto Angling Hydraulic Unit Assy.
16	22460	2	•••• 90 degree Elbow SAE 6
17	05816	1	•••• Lift Cylinder 1" x 6" SAE 6
18	22822	1	•••• Plow Side Harness
19	22427	1	•••• Hose Assembly SAE 6
20	05028	1	•••• Motor Solenoid
21	05026	1	•••• Power Cable
22	05027	1	•••• Motor Solenoid Ground Wire
23	08258	1	•• Plow Parts Carton
24	07650	1	••• Dual Compression Spring Ram
25	13146	2	••• Cart Pivot Bracket
26	15134	2	••• Quart Meyer M-1 Hydraulic Fluid
27	15636	1	••• Front Cover
28	22818	3	••• Plow Cart Caster
29	22823	1	••• Vehicle Side Harness
30	22825	1	••• Vehicle Side Harness Extension
31	22826	1	••• Auto Angling Controller

ITEM	PART NO.	QTY.	DESCRIPTION
	08245	1	••• Mounting Hardware Bag
32	11101	1	•••• Hinge Pin
33	20152	1	•••• Bolt 5/8-11 x 5" Gr. 5
34	20355	6	•••• Flatwasher 1/2"
35	21984	4	•••• Hairpin Cotter
36	22083	1	•••• Lynch Pin
37	20309	1	•••• Locknut 5/8-11
38	22816	2	•••• Pivot Pin 1/2" x 3"
39	22820	1	•••• Fixed Angle Pin
40	22845	2	•••• Hair Pin 1/8" x 1- 5/16"
41	20307	3	•••• Locknut 1/2-13
42	22821	4	•••• Cover Fastener
	09325	1	•• HP-6'8" Moldboard & Pivot Assembly
43	09124	2	••• Eye Bolt Kit
44	09323	1	••• Cutting Edge
45	12978	2	••• Trip Spring
46	13110	1	••• Pivot Bar
47	13125	1	••• HP-6'8" Moldboard
48	20307	6	••• Locknut 1/2-13
49	20357	2	••• Flatwasher 5/8"
50	20385	2	••• Cotter Pin 1/8" x 1-1/4"
51	21943	6	••• Bolt 1/2-13 x 1-3/4" Gr. 5
52	22720	2	••• Pivot Pin 5/8 x 7"

Parts indented are included in the assembly under which they are indented.

PARTS LIST

HOME PLOW

AUTO ANGLING

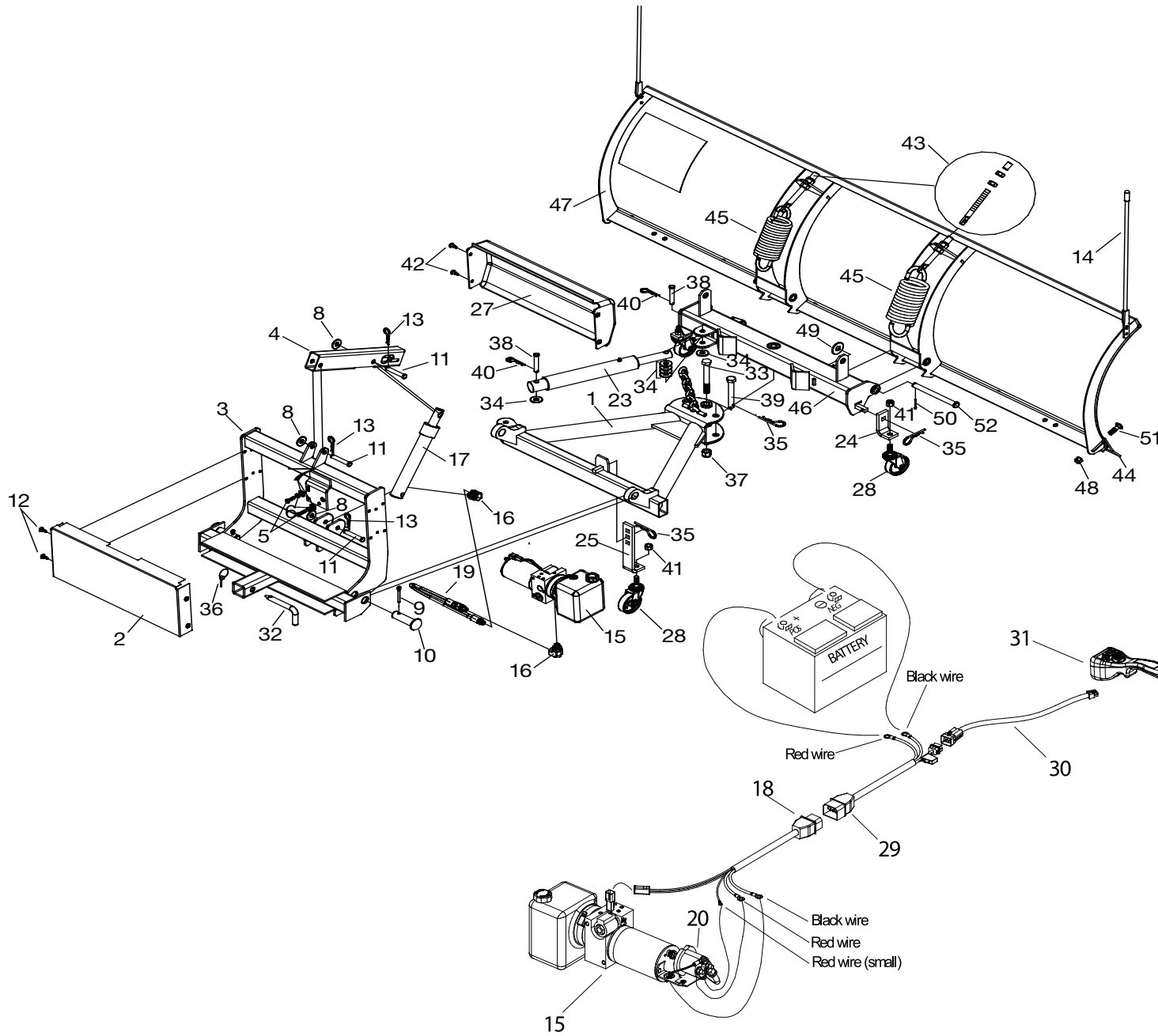

PARTS LIST

HOME PLOW AUTO ANGLING – Hydraulic Unit

ITEM	PART NO.	QTY.	DESCRIPTION
	13851		Home Plow Auto Angling Hydraulic Unit
1	N/A	1	• Base Assy.
2	N/A	1	• Pump Assy.
3	N/A	2	• 1/4 x 3/4" Dowel Pin
4	N/A	1	• Intermediate Shaft
5	N/A	4	• 1/4-20 x 1-1/4" Socket Head Cap Screw
6	15101	1	• Filter Screen
7	15142	1	• Poppet Assy.
8	N/A	1	• Street Elbow 3/8" NPT Black Pipe
9	N/A	1	• Suction Tube
10	N/A	1	• Return Tube
11	15143	1	• Motor 12VDC
12	15144	1	• Reservoir
13	15145	1	• Hose Clamp 2-9/16" - 3-1/2"
14	15067	1	• Reservoir Breather
15	15146	1	• "S1" Cartridge Valve
16	15147	1	• "S1" Coil
17	N/A	1	• Motor Solenoid Mounting Bracket
18	05028	1	• Motor Solenoid
19	N/A	2	• 10-32 x 5/16" Torx Pan Head
20	05027	1	• Motor Solenoid Ground Wire
21	05026	1	• Power Cable 5"

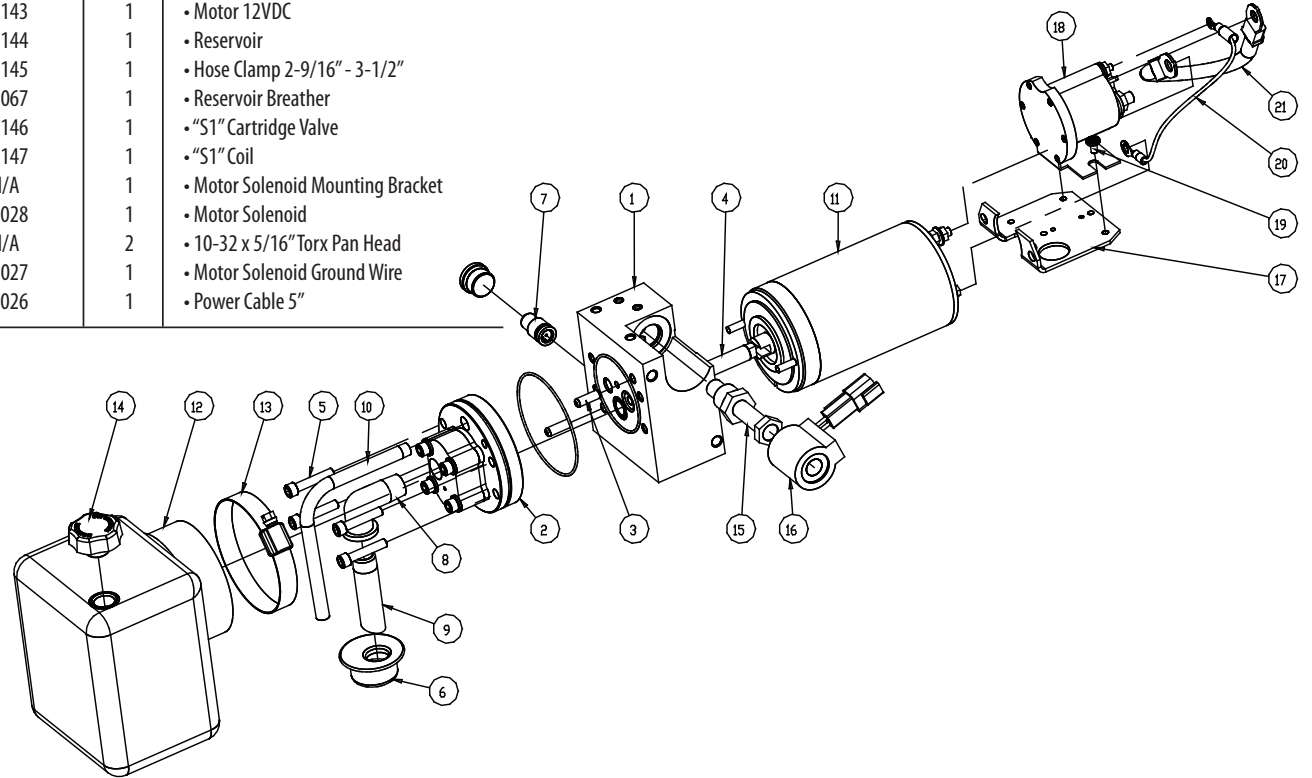

PARTS LIST

HOME PLOW POWER ANGLING

ITEM	PART NO.	QTY.	DESCRIPTION
	26000		Home Plow Power Angling
	16610	1	• Home Plow PAF/Lift Frame Power Angling
	13155	1	•• Lift Frame & Hydraulic Assy
1	13095	1	••• A-Frame
2	13129	1	••• Rear Cover
3	13130	1	••• Lift Frame
4	13142	1	••• Lift Arm
5	20027	3	••• Bolt 5/16-18 x 1" Gr. 2
6	20326	3	••• Lockwasher 5/16"
7	20352	3	••• Flatwasher 5/16"
8	20355	3	••• Flatwasher 1/2"
9	20420	2	••• Cotter Pin 1/4" x 2"
10	22436	2	••• Pin 1" x 3"
11	22816	4	••• Pivot Pin 1/2" x 3"
12	22821	4	••• Cover Fastener
13	22845	4	••• Hair Pin 1/8" x 1- 5/16"
14	09917	1	••• Plow Marker Kit
15	13854	1	••• Power Angling Hydraulic Unit
16	22460	5	•••• 90 degree Elbow SAE 6
17	05816	1	•••• Lift Cylinder 1" x 6" SAE 6
18	05817	1	•••• Dual Acting Angle Cylinder
19	22824	1	•••• Plow Side Harness
20	22427	3	•••• Hose Assembly SAE 6
21	05029	1	•••• Motor Solenoid
22	05030	1	•••• Power Cable 9"
23	05026	1	•••• Power Cable 5"
24	08263	1	•• Plow Parts Carton
25	13146	2	••• Cart Pivot Bracket
26	13147	1	••• Cart Jack Bracket
27	15134	2	••• Quart Meyer M-1 Hydraulic Fluid
28	15636	1	••• Front Cover
29	22818	3	••• Plow Cart Caster
30	22823	1	••• Vehicle Side Harness
31	22825	1	••• Vehicle Side Harness Extension
31	22827	1	••• Power Angling Controller

ITEM	PART NO.	QTY.	DESCRIPTION
	08264	1	••• Mounting Hardware Bag
32	11101	1	•••• Hinge Pin
33	20152	1	•••• Bolt 5/8-11 x 5" Gr. 5
34	20355	6	•••• Flatwasher 1/2"
35	21984	3	•••• Hairpin Cotter
36	22083	1	•••• Lynch Pin
37	20309	1	•••• Locknut 5/8-11
38	22816	2	•••• Pivot Pin 1/2" x 3"
39	22845	2	•••• Hair Pin 1/8" x 1- 5/16"
40	20307	3	•••• Locknut 1/2-13
41	22821	4	•••• Cover Fastener
	09325	1	•• HP-6'8" Moldboard & Pivot Assembly
42	09124	2	••• Eye Bolt Kit
43	09323	1	••• Cutting Edge
44	12978	2	••• Trip Spring
45	13110	1	••• Pivot Bar
46	13125	1	••• HP-6'8" Moldboard
47	20307	6	••• Locknut 1/2-13
48	20357	2	••• Flatwasher 5/8"
49	20385	2	••• Cotter Pin 1/8" x 1-1/4"
50	21943	6	••• Bolt 1/2-13 x 1-3/4" Gr. 5
51	22720	2	••• Pivot Pin 5/8 x 7"

Parts indented are included in the assembly under which they are indented.

PARTS LIST

HOME FLOW

POWER ANGLING

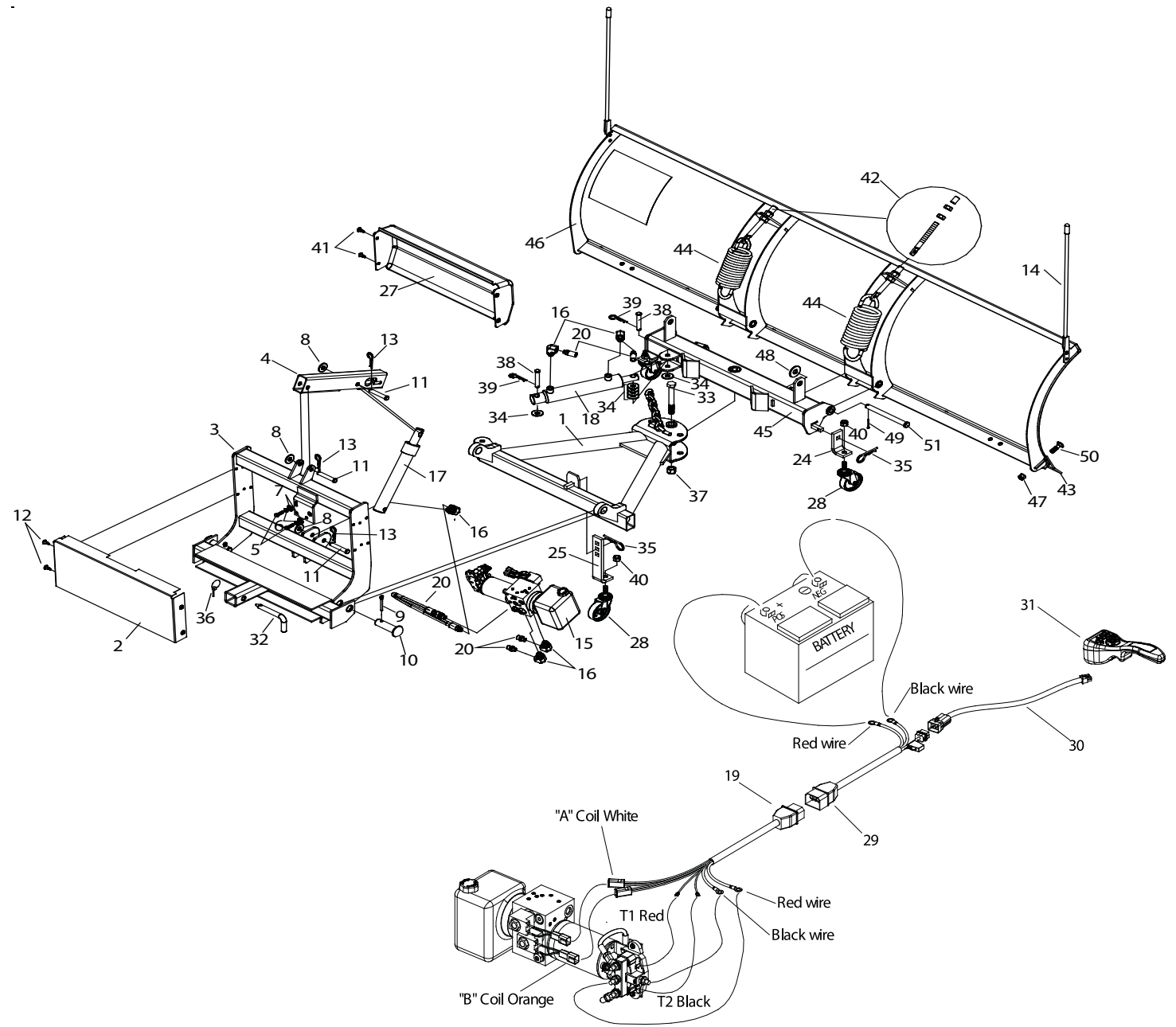

PARTS LIST

HOME PLOW POWER ANGLING – Hydraulic Unit

ITEM	PART NO.	QTY.	DESCRIPTION
	13848		Home Plow Power Angling Hydraulic Unit
1	N/A	1	• Base Assy.
2	N/A	1	• Pump Assy.
3	N/A	4	• 1/4-20 x 1-1/4" Socket Head Cap Screw
4	N/A	2	• 1/4 x 3/4" Dowel Pin
5	N/A	1	• Intermediate Shaft
6	15145	1	• Hose Clamp 2-9/16" - 3-1/2"
7	15067	1	• Reservoir Breather
8	15148	1	• Check Valve Cartridge
9	15149	1	• "S2" Cartridge Valve
10	15146	1	• "S1" Cartridge Valve
11	15150	2	• "S1" & "S2" Coil
12	05029	1	• Motor Solenoid
13	15144	1	• Reservoir
14	N/A	1	• Orifice Plug
15	15143	1	• Motor 12VDC
16	N/A	1	• Motor Solenoid Mounting Bracket
17	N/A	1	• Motor Solenoid Mounting Plate
18	N/A	2	• 10-24 x 3/8" Self Tapping Screw
19	05026	1	• Power Cable 5"
20	N/A	1	• Return Tube
21	N/A	1	• Street Elbow 3/8" NPT Black Pipe
22	N/A	1	• Suction Tube
23	15101	1	• Filter Screen
24	N/A	2	• 10-32 x 7/16" Hex/Washer Screw
25	05030	1	• Power Cable 9"

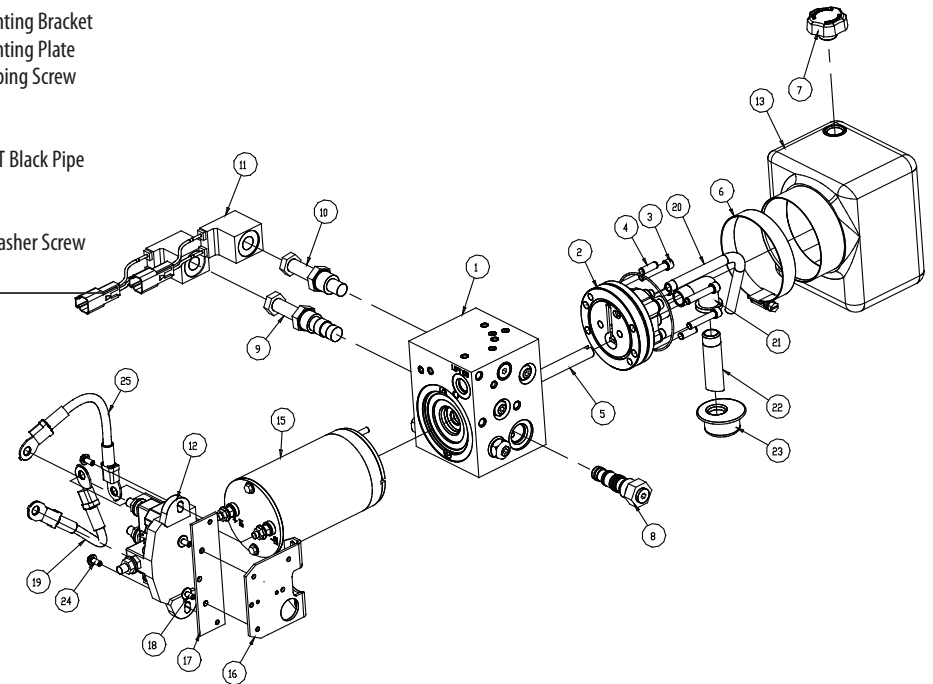

THE HOME PLOW SNOW PLOW LIMITED WARRANTY EFFECTIVE May 1, 2010

The Home Plow, warrants to the original purchaser of Home Plow brand products that they will be free from defects in materials or workmanship for a period of one year from date of purchase to only the original owner.

This warranty does not cover:

- Problems caused by failure to follow the product instructions, failure to maintain the product as described in the Operator's Manual, or failure to maintain proper levels of lubricants;
- Problems caused by contamination or restriction of lubricant systems, or damage resulting from rust, corrosion, freezing or overheating;
- Paint, or expendable snow plow parts such as pins, wheels, cutting edges, chrome plating and springs;
- Damage to any vehicle to which the products are mounted;
- Damage caused by usage that is not in accordance with product instructions, usage in an commercial or heavy duty environment (use of the snow plow for any purpose other than plowing snow is considered misuse and abuse);
- Any snow plow, or any part which has been modified or altered;
- Problems caused by using accessories, parts, or components not supplied by The Home Plow,
- Cost of tax, freight, transportation or storage charges, environmental charges, solvents, sealants, lubricants or any other normal shop supplies.
- Problems caused by collision, fire, theft, vandalism, riot, explosion, lightning, earthquake, windstorm, hail, water, flood, or any other Acts of God;
- Liability for damage to property, or injury to, or death of any person arising out of the operation, maintenance or use of the covered product;
- Products with missing or altered serial numbers;

The Home Plow will repair any product that proves to be defective in materials or workmanship. In the event repair is not possible or practical (as determined by The Home Plow in its sole discretion), The Home Plow will either replace the product with a new product of similar model and price, or refund the full purchase price, as determined by The Home Plow.

Customer must keep the Home Plow System serviced/maintained as recommended by The Home Plow. A written record of service must be maintained, along with receipts for maintenance materials purchased. A copy of the maintenance record and pertinent receipts may be requested in the event of a claim.

THE HOME PLOW

18513 Euclid Avenue
Cleveland, Ohio 44112

800- 412-PLOW (7569)

www.thehomeplow.com

In order to obtain service under this warranty, the original purchaser must:

- Return the claimed defective part to any authorized The Home Plow Dealer, transportation and freight charges prepaid. Only The Home Plow Dealers are authorized to perform the obligations under this warranty. For the address and telephone number of The Home Plow Dealer nearest you, check the telephone directory, go to www.thehomeplow.com, write us at the address to the left, or call (800) 412-PLOW (7569) for assistance;
- Provide maintenance record and receipts for required maintenance, if requested;
- Allow inspection of damaged parts and/or Home Plow System if deemed necessary by The Home Plow.
- It is the responsibility of the original purchaser to establish the warranty period by verifying the original delivery date. A bill of sale/sales receipt, cancelled check or some other appropriate payment record may be kept for that purpose.

EC DECLARATION OF CONFORMITY

The undersigned representing the manufacturer

and the authorized representative
established within the community

herewith declared that the Product: **Snow & Ice Equipment**

Model/Type ref.:

is in conformity with the Essential requirements of the following EC Directives when subject to correct installation, maintenance and use conforming to its(their)intended purpose, to the applicable regulations and standards, to our operation and maintenance manual.

2006/95/EC
2004/108/EC
2006/42/EC

EC Low Voltage Directive
EMC Directive
Machinery Directive

and that the Standards and/or technical specifications referenced below have been applied:

- ✓ BS EN 60204-1:2006 / IEC 60204-1:2005: Safety of machinery – Electrical equipment of machines-Part 1: General requirements.
- ✓ EN ISO 12100-1:2003:Safety of Machinery – Basic Concepts, General Principles of Design Part 1: Basic Terminology and Methodology
- ✓ EN ISO 12100-2:2003:Safety of Machinery – Basic Concepts, General Principles of Design Part 2: Technical principles
- ✓ EN 13021:2003+A1- Winter service machines - Safety requirements
- ✓ EN 61000-6-2: 2005. Generic standards – Immunity for Industrial Environments.
- ✓ EN 61000-6-4:2005. Generic emission standard, Part 2: Industrial environment.

Year of CE Marking:

Manufacturer:

Authorized Representative in the community:

Signature: John A. Kutz
Position: GENERAL MANAGER
Date: 5-14-2010
Place: CLEVELAND, OHIO

Signature _____
Position _____
Date _____
Place _____