



# M5050015A.1

ITEM NUMBER: 5050015

SERIAL NUMBER: \_\_\_\_\_

## Owner's Manual

Instructions for Installation, Operation, and Maintenance

**Battery Charger:** Electrical device for charging NorthStar battery pack #5043106.

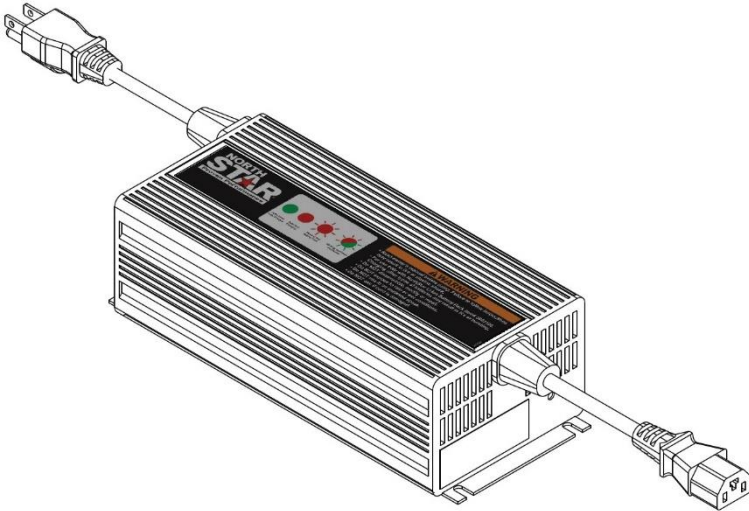

### **WARNING**

To reduce the risk of injury, the user must read and understand the Owner's Manual before using this product.  
Failure to follow instructions may result in fire or electric shock.

**Any Questions, Comments, Problems, or Parts Orders**  
***Call NorthStar Product Support 1-800-270-0810***



## Hazard Signal Word Definitions and Symbols





	This is the safety alert symbol. It is used to alert you to potential personal injury hazards. Obey all safety messages that follow this symbol to avoid possible injury or death.
	DANGER (red) indicates an imminently hazardous situation which, if not avoided, will result in death or serious injury.
	WARNING (orange) indicates a potentially hazardous situation which, if not avoided, could result in death or serious injury.
	CAUTION (yellow) indicates a potentially hazardous situation which, if not avoided, may result in minor or moderate injury.
	CAUTION (yellow) used without the safety alert symbol indicates a potentially hazardous situation which, if not avoided, may result in property damage.

fig01453

Symbols used in this manual or on this product:

Symbol	Definition (units)
V	Voltage (Volt)
A	Current (Ampere)
Hz	Frequency (Hertz)
W	Power (Watt)
~	Alternating current “AC”
==	Direct current “DC”

## Table of Contents

<b>Summary of Important Safety Information</b> .....	4
<b>Warning Label Location</b> .....	5
<b>Component Identification</b> .....	6
<b>Installation</b> .....	7
<b>Operation</b> .....	8
<b>Maintenance and Storage</b> .....	11
<b>Specifications</b> .....	12
<b>Limited Warranty</b> .....	13

## Summary of Important Information

### WARNING

Read and understand **this owner's manual** completely before using the charger. Failure to follow all instructions may result in electric shock, fire, and/or serious personal injury.

**LISTED BELOW is a summary of safety information of particular importance. See individual sections of this owner's manual for more details.**

- Save these instructions – This manual contains important safety and operating instructions for the NorthStar Li-Ion battery charger #5050015.
- Before using the charger, read and understand the owner's manual for this charger, the equipment owner's manual, and the battery pack owner's manual.
- To reduce the risk of injury, charge only NorthStar Li-Ion Battery Pack #5043106 with this charger. Charging other types of batteries may result in fire or bursting.
- Do not use the charger outdoors and do not expose the battery pack or battery charger to rain, snow, or wet locations.
- Do not handle the charger with wet hands. This includes the charger plug.
- Do not use this charger in explosive environments – gas fumes, dusty areas, or flammable materials. Sparks can be generated when the battery is connected to the charger.
- Do not use in an enclosed space. Proper ventilation is required for the charger. Do not block vents and do not allow smoking or open flame near the charger. Keep dust from accumulating on the charger's case.
- Do not charge the battery during operation.
- Do not use if either cord or plug is damaged. Inspect the cord jackets regularly for cuts. Handle the cords safely. Do not unplug by pulling on the cords. Do not carry the charger by either cord. Keep the cords away from oils, sharp edges, and heat. Replace the charger immediately if either of the cords is damaged.
- Do not use an extension cord.
- Charger is rated for 120V only. It must be plugged into an appropriate receptacle. Do not modify the plug.
- Unplug the charger when not in use. Remove battery packs from an unplugged charger.
- To reduce the risk of shock, always unplug the charger before cleaning. Do not use water or any solvents for cleaning. Surface of charger can be wiped with a dry rag or blown off with low pressure air.
- Do not burn or incinerate the battery charger.
- Do not disassemble the battery charger.

## Warning Label Location

### **⚠ WARNING**

- Read owner's manual before using. Failure to follow instructions may result in fire or electric shock.
- For use only with NorthStar Li-Ion Battery Pack item# 5043106. Charging other types of batteries may result in fire or bursting.
- Do NOT disassemble, modify or repair.
- Do NOT expose to rain or wet conditions.
- Do NOT use in an enclosed space.
- Do NOT use if cord is damaged.

804766

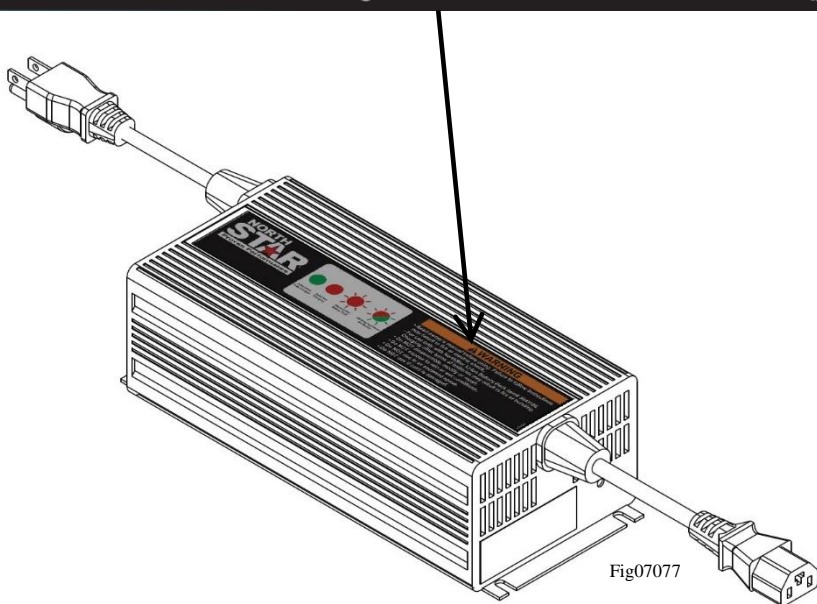

Fig07077

Part#	Description
804766	Decal, Charger

**Always make sure safety labels are in place and in good condition.** If a safety label is missing or not legible, order new labels or unsafe operation could result.

**To order replacement safety labels, call NorthStar Product Support at 1-800-270-0810.**

## Component Identification

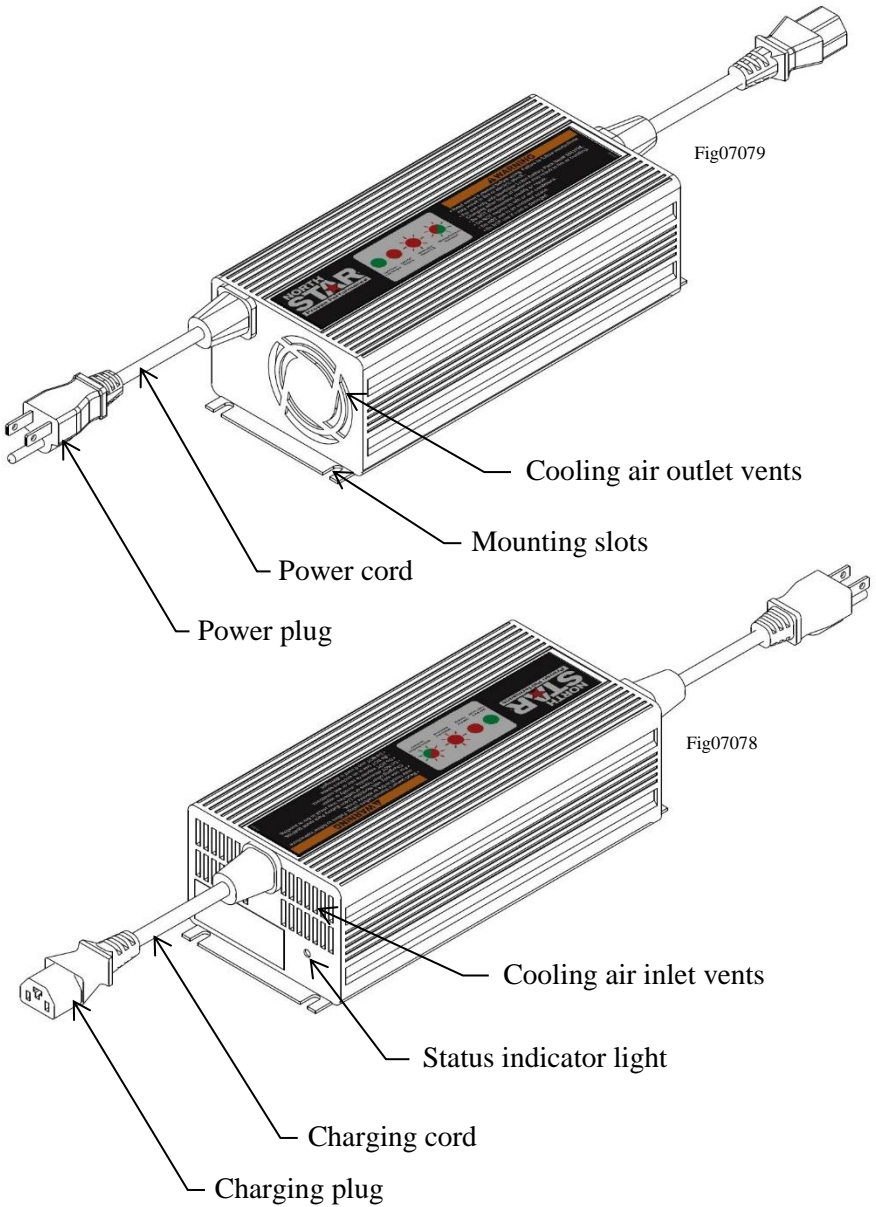

## Installation

### **⚠ WARNING**

The charger should be installed indoors in a well-ventilated, dry location.

#### **1. Mount the charger**

If desired, the charger can be attached to a shelf or wall using the mounting slots on the charger's base.

**Hole pattern is:**

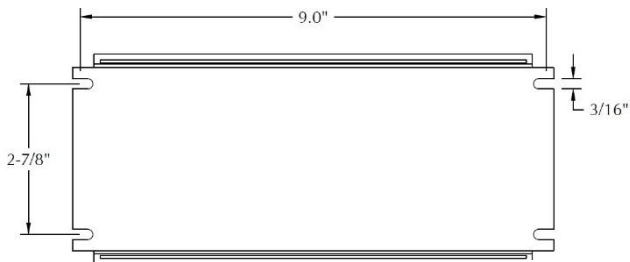

Fig07080

**Note:** The charger can be mounted in any orientation. However, the cooling air inlet and outlet vents must not be obstructed.

## Operation

### **⚠ WARNING**

Do not attempt to charge batteries other than NorthStar Li-Ion battery pack #5041036. Charging other batteries may result in fire or bursting.  
Do not use outdoors and do not expose to rain or wet conditions.  
Do not handle charger with wet hands.

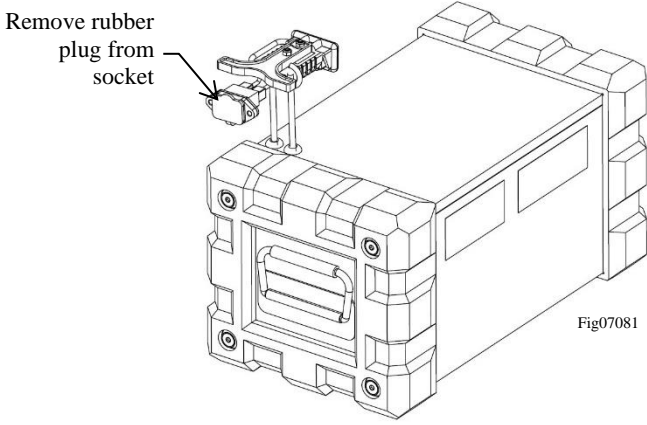
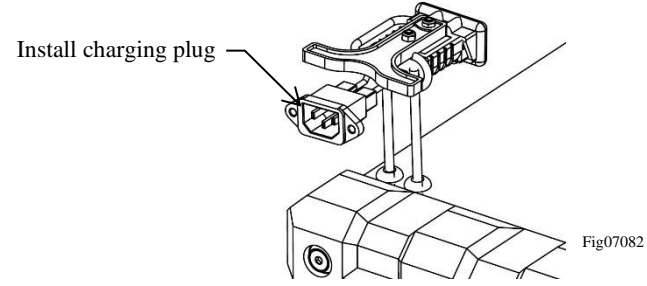
<b>1. Connect the power cord to power supply</b>	The status indicator light will shine green, indicating the charger is working correctly.
<b>2. Attach the charging cord to the battery</b>	<p>The charger can be connected to the battery using two different methods:</p> <p>a) Directly to the battery – connect the charging plug to the charging socket on the battery wire harness</p> <p>Remove rubber plug from socket</p>  <p>Fig07081</p> <p>Install charging plug</p>  <p>Fig07082</p>



## Operation

- b) Directly to the battery box on the equipment – connect the charging plug to the charging socket on the battery box control panel.

Notes: The battery's power plug must be connected to the receptacle inside the battery box if charging by this method.

- Do not charge the battery during operation. This can damage the battery.

### Sprayer Battery Box:

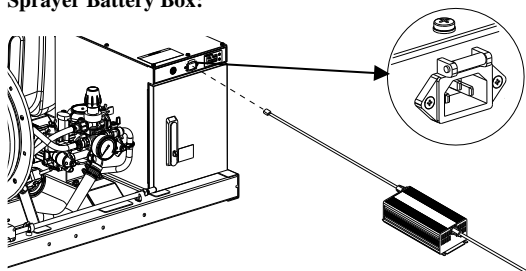

### Log Splitter Battery Box:

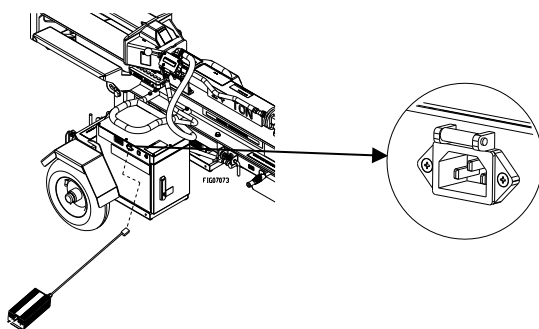

### 3. Monitor charging status

The status indicator light will shine red while the battery pack is charging.

When the battery pack is fully charged, the status indicator light will shine green.

Disconnect the charger from the battery pack or from the battery box when fully charged.

## Operation

Charger indicator status light functions:

Indicator light	Status	Action
Solid Green	Battery fully charged	Charging complete
	Nothing connected	Inactive
Solid Red	Battery charging	Charging
Blinking Red	Battery fault	Battery pack or charger is defective
Blinking Red/Green	Battery overheated	Wait for battery temperature to return to normal, then try charging again.
No light	Malfunction	Charger is broken, the power cord is not plugged in, or there is no power at the outlet.

<b>1. Charging a hot or cold battery pack</b>	<p>The battery pack will not charge correctly if its temperature is below 32°F (0°C) or above 105°F (40°C). Ensure the battery pack is within these limits before attaching to the charger.</p>
<b>2. Defective battery pack</b>	<p>A battery fault is indicated by a blinking red light. Ensure the battery pack is within the specified charging temperature range, then unplug the battery, wait a few seconds, and plug the battery in again.</p> <p>If the problem is not solved, and the charger is connected to the battery box enclosure on the product, remove the battery from the enclosure and connect the charger directly to the charging port on the battery pack.</p> <p>Call product support if the battery fault indicator light code persists.</p>

## Maintenance and Storage

### **WARNING**

Do not disassemble or attempt to modify or repair the charger.

The charger has no serviceable parts and the only maintenance required is periodic inspection and cleaning.

1. Inspect cords regularly for damage or cuts. Discontinue use immediately if damage is found.
2. Keep charger case clean and free of dust. Dust build-up will inhibit the cooling effect of the internal fan. Use a clean cloth to wipe dust from the exterior of the case or blow dust off with low pressure air.

Store the charger in a cool, dry location. Unplug the charger from the power source and disconnect the battery.

## Specifications

Item#	5050015
Charger input	120V~60Hz, 7A max
Charger output	65.7V $\pm$ , 8A max
Compatibility	NorthStar battery pack #5043106
Charging temp	32°F~105°F (0°C~40°C)
Weight	4.25 lbs
Charging time	3.5 hours for exhausted battery

**Any Questions, Comments, Problems or Parts Orders**  
***Call NorthStar Product Support 1-800-2700***

## Limited Warranty

Dear Valued Customer:

The NorthStar Product you just purchased is built with the finest material and craftsmanship. Use this product properly and enjoy the benefits from its high performance. By purchasing a NorthStar product, you show a desire for quality and durability. Like all mechanical equipment this unit requires a due amount of care. Treat this unit like the high-quality piece of machinery it is. Neglect and improper handling may impair its performance. Please thoroughly read the instructions and understand the operation before using your product.

### Limited Warranty

NorthStar shall warranty any piece of equipment manufactured, or parts of equipment manufactured, to be free from defects in material or workmanship for a period of 2 years from the date of purchase by user.

NorthStar shall warranty any wear item, including, but not limited to, valves, seals, pump diaphragms, hoses, and filter elements to be free from defects in material or workmanship for a period of 90 days from the date of purchase by user. This warranty applies to the original purchaser of the equipment and is non-transferable. Verification of purchase is the responsibility of the buyer. Parts will be replaced or repaired at no charge, except when the equipment has failed due to lack of proper maintenance. Any misuse, abuse, alteration or improper installation or operations will void warranty. Determining whether a part is to be replaced or repaired is the sole decision of NorthStar.

**NOTE:** Some services performed by parties other than NorthStar may void warranty.

This warranty specifically excludes the following: failure of parts due to damage caused by accident, fire, flood, windstorm, acts of God, applications not approved by NorthStar in writing, corrosion caused by chemicals, use of replacement parts which do not conform to manufacturer's specifications, and damage caused by vandalism. Additional exclusions: loss of running time, inconvenience, loss of income, or loss of use, including any implied warranty of merchantability of fitness for a specific use.

Warranty does not cover items subject to normal wear such as tires, receptacles or any part subject to direct physical contact by the public. This warranty does not cover any personal injury or damage to surrounding property caused by failure of any part.

This warranty is in lieu of any other warranty expressed or implied and NorthStar assumes no other responsibility or liability outside that expressed within this warranty.

Please fill in the following information and have it on hand when you call in on a warranty claim.

Customer Number: \_\_\_\_\_

Date of Purchase: \_\_\_\_\_

NorthStar Serial Number: \_\_\_\_\_

Item Number: \_\_\_\_\_



Northern Tool + Equipment Co., Inc.  
Burnsville, MN 55306  
NorthernTool.com  
Made in China