



# M5043106A.1

ITEM NUMBER: 5043106

SERIAL NUMBER: \_\_\_\_\_

## Owner's Manual

Instructions for Installation, Operation, and Maintenance

**Li-Ion Battery Pack:** Electrical device for operating NorthStar Li-Ion Sprayer #5042373 or NorthStar Li-Ion Log Splitter #5044310

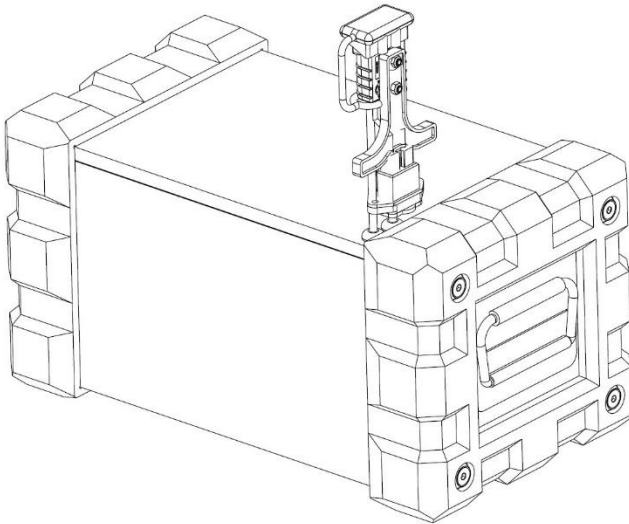

### **WARNING**

To reduce the risk of injury, the user must read and understand the Owner's Manual before using this product.

Failure to follow instructions may result in fire or electric shock.

**Any Questions, Comments, Problems, or Parts Orders**  
*Call NorthStar Product Support 1-800-270-0810*



## Hazard Signal Word Definitions and Symbols







	This is the safety alert symbol. It is used to alert you to potential personal injury hazards. Obey all safety messages that follow this symbol to avoid possible injury or death.
	DANGER (red) indicates an imminently hazardous situation which, if not avoided, will result in death or serious injury.
	WARNING (orange) indicates a potentially hazardous situation which, if not avoided, could result in death or serious injury.
	CAUTION (yellow) indicates a potentially hazardous situation which, if not avoided, may result in minor or moderate injury.
	CAUTION (yellow) used without the safety alert symbol indicates a potentially hazardous situation which, if not avoided, may result in property damage.

fig01453

Symbols used in this manual or on this product:

Symbol	Definition (units)
V	Voltage (Volt)
A	Current (Ampere)
Hz	Frequency (Hertz)
W	Power (Watt)
~	Alternating current “AC”
==	Direct current “DC”
	Do not dispose of battery packs into household waste. Dispose of battery packs promptly according to local recycling or waste regulations.

# Table of Contents

<b>Summary of Important Safety Information .....</b>	<b>4</b>
<b>Warning Label Location .....</b>	<b>5</b>
<b>Component Identification .....</b>	<b>6</b>
<b>Operation</b>	
<b>Install in Equipment.....</b>	<b>7</b>
<b>Charging.....</b>	<b>10</b>
<b>Maintenance and Storage.....</b>	<b>13</b>
<b>Specifications .....</b>	<b>14</b>
<b>Parts Breakdown – Exploded View.....</b>	<b>15</b>
<b>Limited Warranty .....</b>	<b>16</b>

## Summary of Important Information

### WARNING

Read and understand **this owner's manual** completely before using the battery pack. Failure to follow all instructions may result in electric shock, fire, and/or serious personal injury.

**LISTED BELOW is a summary of safety information of particular importance. See individual sections of this owner's manual for more details.**

- Save these instructions – This manual contains important safety and operating instructions for the NorthStar Li-Ion battery pack #5043106.
- Before using the battery pack, read and understand the owner's manual for this battery pack, the equipment owner's manual, and the battery charger owner's manual.
- To reduce the risk of injury, charge with only NorthStar Charger #5050015. Using other chargers may result in fire and/or bursting (explosion).
- Do not drop, disassemble, modify, crush, pierce, or attempt to repair the battery pack.
- Do not use the charger outdoors and do not expose the battery pack or battery charger to rain, snow, or wet locations.
- Do not expose the battery pack to fire or extreme temperatures. Do not burn or incinerate the battery pack or the charger.
- Do not short terminals. Keep paper clips and other metal objects away from the battery's terminals.
- Always keep rubber covers on the main power plug and charging port when not in use.
- Do not handle the battery or charger with wet hands.
- Do not charge the battery in explosive environments – gas fumes, dusty areas, or flammable materials. Sparks can be generated when the battery is connected to the charger.
- Do not charge in an enclosed space. Proper ventilation is required for the charger. Do not block vents and do not allow smoking or open flame near the charger. Keep dust from accumulating on the charger's case.
- Do not charge the battery during operation.
- Do not use if wires, cords, or plugs are damaged. Inspect the wire and cord jackets regularly for cuts. Handle the cords safely. Do not unplug by pulling on the cords. Do not carry the battery by its wires. Keep cords, wires, and terminals away from oils, sharp edges, and heat. Replace the battery pack immediately if wires or terminals are damaged.
- Do not attach an extension cord to the charger.
- Remove battery packs from an unplugged charger. Unplug the charger when not in use.
- To reduce the risk of shock, always unplug the charger before cleaning. Do not use water or any solvents for cleaning. Surface of charger can be wiped with a dry rag or blown off with low pressure air.
- Do not disassemble the battery pack.
- In the event of a cell leaking, do not allow the liquid to touch skin or eyes. If contact has been made, wash the affected area with large amounts of water and seek medical advice.
- Upon removal of the battery pack for disposal or recycling, cover the battery pack's power plug and charging plug with the included rubber covers and heavy-duty tape.
- Keep away from children.

## Warning Label Location

⚠ WARNING

- Read owner's manual before using. Failure to follow instructions may result in fire or electric shock.
- Charge only with NorthStar Charger item# 5050015.  
Using other chargers may result in fire and/or bursting (explosion).
- Do NOT drop, disassemble, modify, crush, pierce, or attempt to repair.
- Do NOT expose to water, fire, or extreme temperatures.
- Do NOT short terminals, may cause burns or a fire.
- Do NOT charge or use if damaged.
- Store indoors in a cool, dry, ventilated environment.

804768

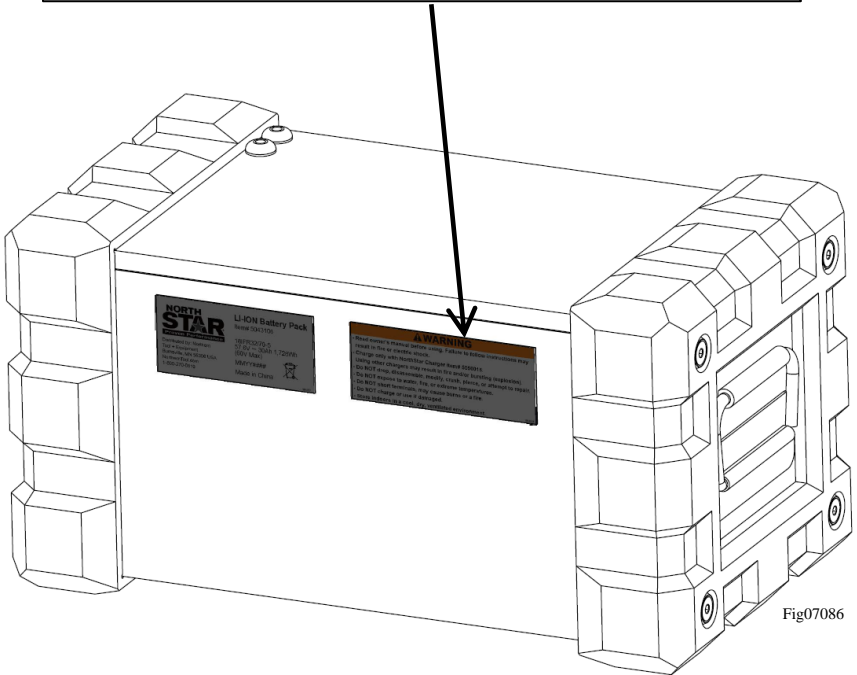

Fig07086

Part#	Description
804768	Decal, Battery Warning

**Always make sure safety labels are in place and in good condition.** If a safety label is missing or not legible, order new labels or unsafe operation could result.

**To order replacement safety labels, call NorthStar Product Support at 1-800-270-0810.**

## Component Identification

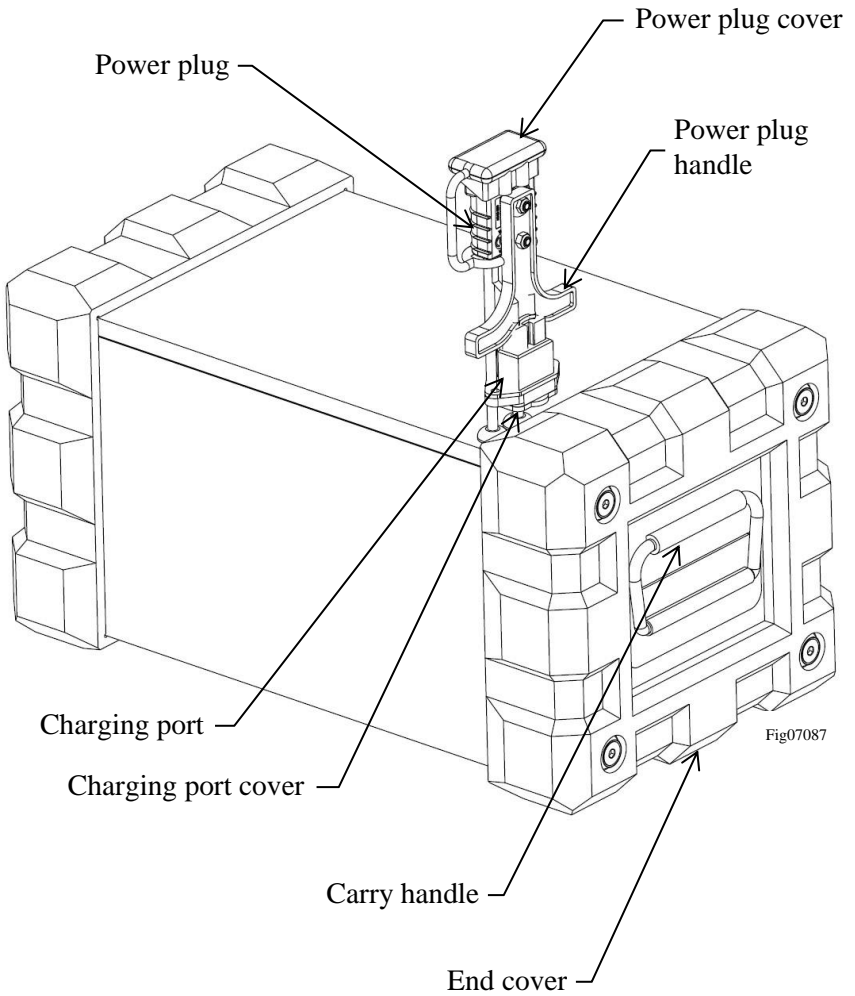

## Operation – Install in Equipment

### WARNING

Use both carry handles to move battery pack. Do not lift, push, or pull battery pack by the wires, terminals, or end covers.

Do not drop battery pack or expose it to water, fire, or extreme temperatures.

Use caution not to pinch or crush wires or terminals.

Do not use if damaged.

### 1. Install the battery pack into equipment

NOTE: The sprayer is used as an example, but the procedure is the same for the log splitter.

- a. Ensure main power switch on the battery box control panel is in the Off position.

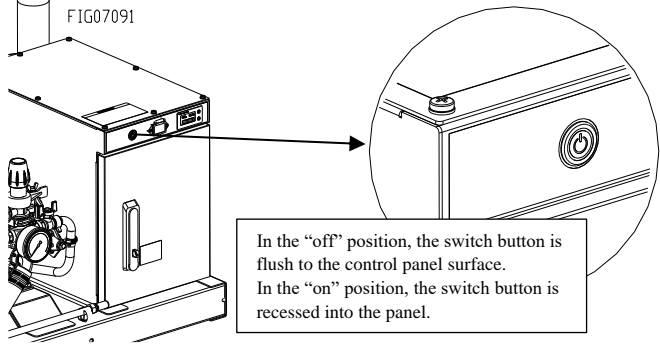

- b. Open battery enclosure door by lifting and rotating the handle.

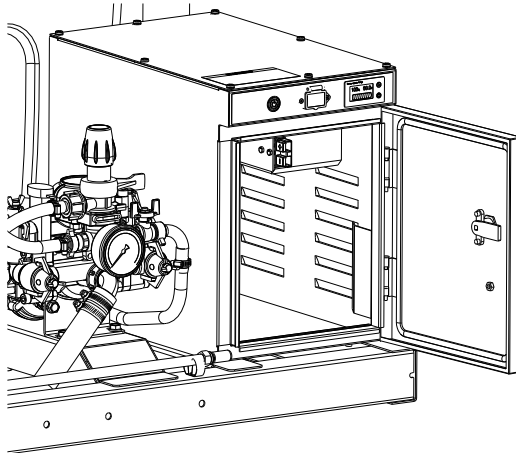
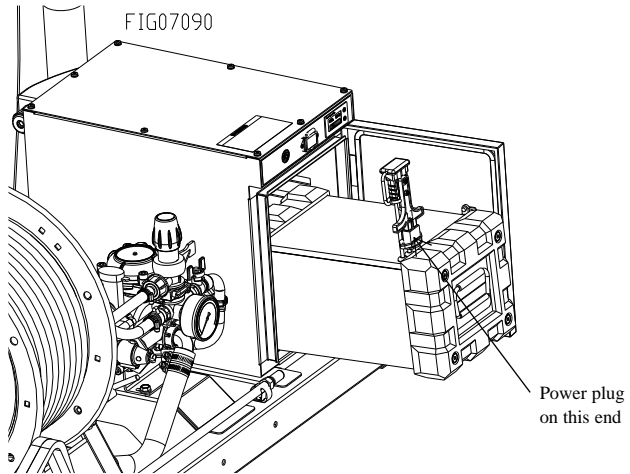

FIG07089

## Operation – Install in Equipment

c. Using both carry handles, place the end of the battery pack opposite the power plug just inside the battery box enclosure.



d. Make sure all wires and terminals are hanging over the outside end of the battery pack so they do not get pinched or damaged.

e. Slide the battery pack into the battery box until it reaches the back of the battery box. The front of the battery pack should be resting on the bottom of the battery box just inside the door.

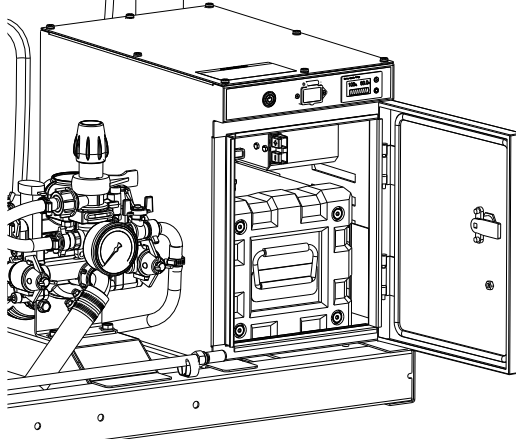
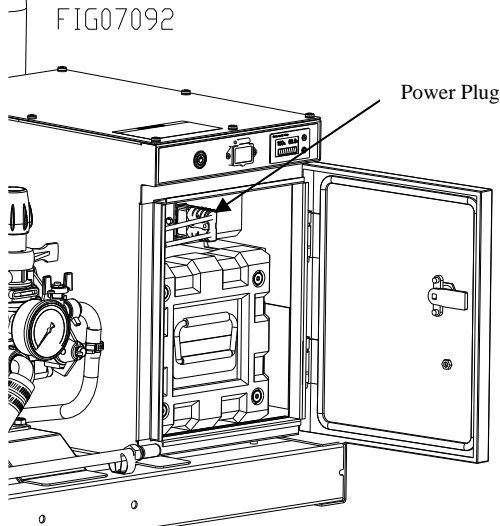

FIG07072

## Operation – Install in Equipment

f. Remove the power plug cover and use the power plug handle to insert the power plug into the receptacle mounted inside the battery box.



g. Close and latch the battery box door.

### 2. Remove the battery pack from equipment

a. Ensure main power switch on the battery box control panel is in the Off position.

b. Open battery enclosure door by lifting and rotating the handle.

c. Using the power plug handle, disconnect the power plug from the receptacle in the battery box.

d. Install the power plug cover.

e. Use the carry handle to lift the battery pack over the door's front lip and pull it out of the battery box until the rear end cover contacts the door's front lip. Reach into the battery box and grab the second carry handle, then lift the battery out of the battery box.

## Operation - Charging

### **WARNING**

Charge only with NorthStar Charger item# 5050015. Using other chargers may result in fire and/or bursting (explosion).  
Do not charge or use if damaged.

**1. Connect the charger's power cord to power supply**

The status indicator light on the charger will shine green, indicating the charger is working correctly.

**2. Attach the charging cord to the battery**

The charger can be connected to the battery using two different methods:  
a. Directly to the battery – connect the charging plug to the charging socket on the battery wire harness

Remove rubber plug from socket

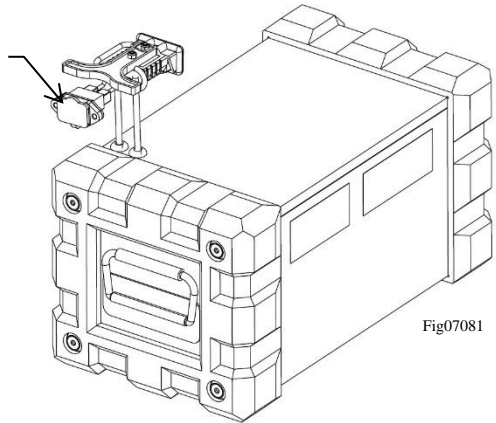

Fig07081

Install charging plug

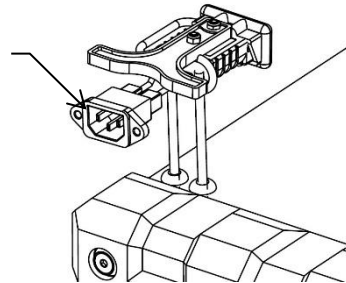

Fig07082

## Operation - Charging

- b. Directly to the battery box on the equipment – connect the charging plug to the charging socket on the battery box control panel.

Notes: The battery's power plug must be connected to the receptacle inside the battery box if charging by this method.

- Do not charge the battery during operation. This can damage the battery.

### Sprayer Battery Box:

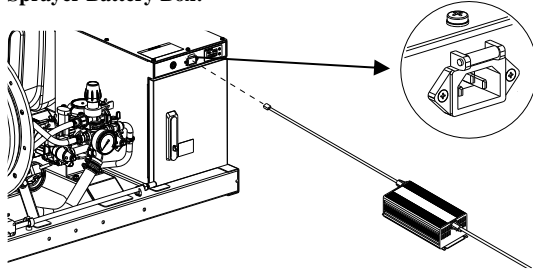

### Log Splitter Battery Box:

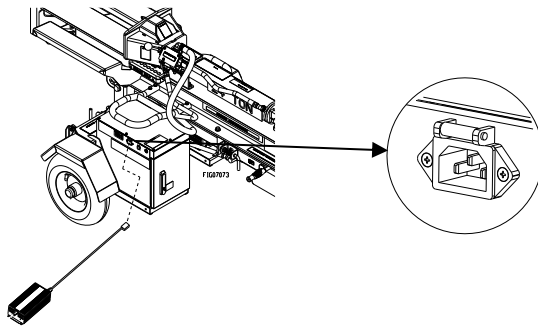

### 3. Monitor charging status

The status indicator light on the charger will shine red while the battery pack is charging.

When the battery pack is fully charged, the status indicator light will shine green.

Disconnect the charger from the battery pack or from the battery box when fully charged.

## Operation - Charging

### Charger LED functions

LED Indicator	Status	Action
Solid Green	Battery fully charged	Charging complete
	Nothing connected	Inactive
Solid Red	Battery charging	Charging
Blinking Red	Battery fault	Battery pack or charger is defective
Blinking Red/Green	Battery overheated	Wait for battery temperature to return to normal, then try charging again.
No light	Malfunction	Charger is broken, the power cord is not plugged in, or there is no power at the outlet.

<b>1. Charging a hot or cold battery pack</b>	<p>The battery pack will not charge correctly if its temperature is below 32°F (0°C) or above 105°F (40°C). Ensure the battery pack is within these limits before attaching to the charger.</p>
<b>2. Defective battery pack</b>	<p>A battery fault is indicated by a blinking red light. Ensure the battery pack is within the specified charging temperature range, then unplug the battery, wait a few seconds, and plug the battery in again. If the problem is not solved, and the charger is connected to the battery box enclosure on the product, remove the battery from the enclosure and connect the charger directly to the charging port on the battery pack. Call product support if the battery fault indicator light code persists.</p>

## Maintenance and Storage

### **WARNING**

Do not drop, disassemble, modify, crush, pierce, or attempt to repair the battery pack.

Do not short terminals, may cause burns or a fire.

Do not charge or use if damaged.

Store indoors in a cool, dry, ventilated environment.

The battery pack has no serviceable internal parts.

Periodic inspection and cleaning are required.

1. Inspect wires regularly for damage or cuts. Discontinue use immediately if damage is found.
2. Ensure the power plug cover and charging port cover are in good condition and stay firmly fitted when installed. Replace as needed.
3. Keep battery case clean and free of dust. Dust build-up will reduce heat dissipation from the battery case. Battery case material is 304 stainless steel. It can be cleaned with a mild detergent and cloth. For stubborn stains, a stainless steel cleaner can be used.
4. Avoid cleaning agents that are harmful to plastic or rubber. A few examples are gasoline, turpentine, paint thinner, and ammonia. Never use flammable or combustible solvents around batteries, charger, or equipment.

Storage:

1. Store the battery indoors in a cool, dry, ventilated environment.
2. Unplug the battery from the charger.
3. Keep the battery's charge above 50%. Charge the battery at least once every three months.
4. Do not stack items on top of the battery.
5. Inspect the battery and wires for any damage prior to use.

## **Specifications**

Item #	5043106
Battery Chemistry	Lithium Iron Phosphate
Battery Voltage	57.6V <sup>==</sup> (60V Max)
Battery Capacity	30Ah, 1,728Wh
Battery Charger	NorthStar Charger #5050015
Charging temp	32°F~105°F (0°C~40°C)
Weight	35 lbs
Charging time	3.5 hours for exhausted battery

**Any Questions, Comments, Problems or Parts Orders**  
***Call NorthStar Product Support 1-800-2700***

## Parts Breakdown

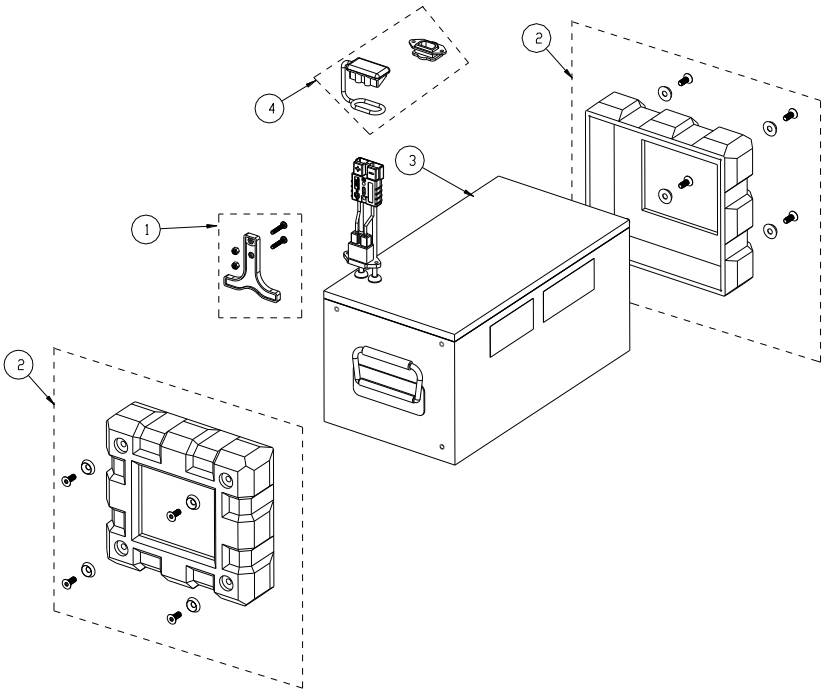

REF #	PART #	DESCRIPTION	QTY
1	805117	HANDLE KIT (INCLUDES ITEMS LISTED BELOW)	1
-	-	HANDLE	1
-	-	SCREW, M3 -0.5 X 20mm PPHM	2
-	-	NUT, M3 -0.5 NYLOC	2
2	805118	END CAP KIT (INCLUDES ITEMS LISTED BELOW)	1
-	-	END CAP	2
-	-	WASHER, M6 COUNTERSUNK	8
-	-	SCREW, M6 -1 X 16mm FLATHEAD	8
3	5043106	BATTERY, 60V/30Ah	1
4	805119	COVER KIT (MAIN CONNECTOR & CHARGE PORT)	1

## Limited Warranty

Dear Valued Customer:

The NorthStar Product you just purchased is built with the finest material and craftsmanship. Use this product properly and enjoy the benefits from its high performance. By purchasing a NorthStar product, you show a desire for quality and durability. Like all mechanical equipment this unit requires a due amount of care. Treat this unit like the high-quality piece of machinery it is. Neglect and improper handling may impair its performance. Please thoroughly read the instructions and understand the operation before using your product.

### Limited Warranty

NorthStar shall warranty any piece of equipment manufactured, or parts of equipment manufactured, to be free from defects in material or workmanship for a period of 1 year from the date of purchase by user.

NorthStar shall warranty any wear item, including, but not limited to, valves, seals, pump diaphragms, hoses, and filter elements to be free from defects in material or workmanship for a period of 90 days from the date of purchase by user. This warranty applies to the original purchaser of the equipment and is non-transferable. Verification of purchase is the responsibility of the buyer. Parts will be replaced or repaired at no charge, except when the equipment has failed due to lack of proper maintenance. Any misuse, abuse, alteration or improper installation or operations will void warranty. Determining whether a part is to be replaced or repaired is the sole decision of NorthStar.

**NOTE:** Some services performed by parties other than NorthStar may void warranty.

**This warranty covers parts only. It will not provide for replacement of complete products due to defective parts.**

**Components not manufactured by NorthStar are guaranteed by their manufacturer and can be serviced at factory-authorized locations near you. Any costs incurred due to replacement or repair of items outside of a NorthStar approved facility is the responsibility of the buyer and not covered under warranty. NorthStar can supply you with the service center location in your area.**

This warranty specifically excludes the following: failure of parts due to damage caused by accident, fire, flood, windstorm, acts of God, applications not approved by NorthStar in writing, corrosion caused by chemicals, use of replacement parts which do not conform to manufacturer's specifications, and damage caused by vandalism. Additional exclusions: loss of running time, inconvenience, loss of income, or loss of use, including any implied warranty of merchantability of fitness for a specific use.

Warranty does not cover items subject to normal wear such as tires, receptacles or any part subject to direct physical contact by the public. This warranty does not cover any personal injury or damage to surrounding property caused by failure of any part.

This warranty is in lieu of any other warranty expressed or implied and NorthStar assumes no other responsibility or liability outside that expressed within this warranty.

Please fill in the following information and have it on hand when you call in on a warranty claim.

Customer Number: \_\_\_\_\_

Date of Purchase: \_\_\_\_\_

NorthStar Serial Number: \_\_\_\_\_

Item Number: \_\_\_\_\_

*This page has intentionally been left blank.*



Northern Tool + Equipment Co., Inc.  
Burnsville, MN 55306  
NorthernTool.com  
Made in China