



# M5042373B

ITEM NUMBER: 5042373

SERIAL NUMBER: \_\_\_\_\_

## Owner's Manual

Instructions for Assembly, Testing, Operation, Servicing, and Storage  
**Skid Sprayer:** Agricultural product used to spray herbicides, pesticides  
and insecticides.\*\*

### ⚠ WARNING

**READ and UNDERSTAND the Owner's Manual completely before using this sprayer.** Assemble, test, and use only in accordance with the Owner's Manual instructions.

**READ and FOLLOW chemical label instructions.** Pesticides are hazardous chemicals.

**KNOW emergency procedures BEFORE handling chemicals.** Sprayer leaks, bodily chemical contact, poisoning, and spills require immediate response.

**AVOID inhaling, ingesting, or coming into contact with any chemicals.**

**WEAR personal protective gear when filling, using, cleaning, and servicing the sprayer.**

**KEEP sprayer and spray materials away from children and pets.** Pesticides are especially toxic to them.

**DO NOT START sprayer until ready to spray** in order to avoid unintentional spray release.

**EXERCISE CAUTION in vehicle handling when driving with filled sprayer** to avoid loss of control or rollover.

**ALWAYS keep a fire extinguisher rated "ABC" nearby**

**Improper use of the sprayer or handling of chemicals could result in serious injury or illness to the operator or nearby persons/animals or could cause damage to the environment.**

### Equipment Protection Quick Facts

**Inspect Upon Delivery:** FIRST! Inspect for missing or damaged components. See "*Unpacking*" section for where to report missing or damaged parts.

**Check Pump Oil Level:** Pump is shipped with oil. Check pump oil level before starting. See pump manual for instructions on capacity and viscosity recommendations.

**Chemical Spraying:** Use only chemicals compatible with all materials in the spraying system. See "Specifications" section for a list of materials.

**Storage:** Do not allow water to freeze in the pump, hose, or spray gun(s). See "Storage" for more information.

**Maintenance Schedule:** Pump requires periodic inspection and servicing to keep sprayer functioning efficiently. See pump manual for frequency of servicing.

**Battery Recycling:** To protect the environment, do not dispose of the battery using standard waste collection. Observe local laws and regulation for disposal.

\*\* These sprayers are recommended for use in spraying non-flammable liquids such as pesticides, or water for plants/trees or dust control. However, WE RECOMMEND THAT THE SPRAYERS ARE NOT USED FOR OTHER PURPOSES ONCE IT HAS BEEN USED FOR SPRAYING PESTICIDES. Any chemical will leave some residual in the tank liner or sprayer components, even after the sprayer has been properly cleaned. These residual chemicals can have unexpected effects on future uses. For example, spraying water or other liquids that are contaminated with residual pesticide may result in unforeseen hazards to plant or animal life.

**Any Questions, Comments, Problems, or Parts Orders**

*Call NorthStar Product Support 1-800-270-0810*

## Hazard Signal Word Definitions





	<p>This is the safety alert symbol. It is used to alert you to potential personal injury hazards. Obey all safety messages that follow this symbol to avoid possible injury or death.</p>
	<p>DANGER (red) indicates an imminently hazardous situation which, if not avoided, will result in death or serious injury.</p>
	<p>WARNING (orange) indicates a potentially hazardous situation which, if not avoided, could result in death or serious injury.</p>
	<p>CAUTION (yellow) indicates a potentially hazardous situation which, if not avoided, may result in minor or moderate injury.</p>
	<p>CAUTION (yellow) used without the safety alert symbol indicates a potentially hazardous situation which, if not avoided, may result in property damage.</p>

fig01453

# Table of Contents

<b>Intended Use</b> .....	4
<b>Summary of Important Safety Information</b> .....	5
During Assembly	
During Operation	
• General Chemical Safety	
• Chemical Application Safety	
• Transporting Safety	
• Chemical Accident Procedures	
During Storage / Troubleshooting	
<b>Warning Label Locations</b> .....	8
<b>Unpacking</b>	
Unpacking .....	10
<b>Assembly</b>	
Step One: Attach hose reel handle to the hose reel .....	11
Step Two: Attach the sprayer to the vehicle .....	11
Step Three: Check and test completed assembly .....	12
<b>Machine Components</b> .....	13
<b>Operation</b>	
<b>Operation - Important Safety Information</b> .....	14
• General Chemical Safety	
• Chemical Application Safety	
• Transportation Safety	
• Chemical Accident Procedures	
<b>Operation - Preparing the Sprayer for Each Use</b>	
Step One: Inspect/Repair .....	19
<b>Operation - Using the Sprayer</b>	
Step One: Assess wind conditions and clear work area .....	23
Step Two: Check and set accumulator pressure .....	23
Step Three: Fill the sprayer .....	24
Step Four: Operate the sprayer .....	26
Step Five: Clean sprayer and decontaminate after use .....	30
<b>Storage</b> .....	32
Preparing for storage	
Removing from storage	
<b>Troubleshooting</b> .....	33
<b>Specifications</b> .....	34
<b>Sprayer Exploded View</b> .....	35
<b>Pump Exploded View</b> .....	38
<b>Limited Warranty</b> .....	41
<b>California Proposition 65 Information</b> .....	42

## Intended Use

The sprayer is intended for use in spraying residential, commercial, or agricultural pesticides and other non-flammable liquids.

### **SPRAYING PESTICIDES:**

Pesticides are hazardous chemicals that must be handled with caution as directed throughout this manual and on the pesticide label. Pesticides are regulated by the United States Environmental Protection Agency (EPA) and defined as:

*Any substance or mixture of substances intended for preventing, destroying, repelling, or mitigating any pest. Though often misunderstood to refer only to insecticides, the term pesticide is a comprehensive term that applies to insecticides, herbicides, fungicides, and various other substances used to control pests.*

The sprayer is intended for use in spraying pesticides in liquid form only. The sprayer is NOT intended for use in spraying pesticides in dry or aerosolized form, or for use with fumigants.

Some formulations of liquid pesticides do not remain in solution and should be agitated to maintain a uniform mix. This sprayer is equipped with an **agitator** that should be used when spraying pesticides classified as “flowable” (“F” or “L”), “wettable powder” (“WP” or “W”), “emulsion” (“EC” or “E”), “microencapsulated” (“M”), or water dispersible granules (“WDG” or “DF”). (See pesticide label to determine its classification.)

This sprayer comes equipped with a spray gun for applying pesticides on selected plants. If you wish to spray large ground areas, a broadcast kit (Item #5042381), is available as an optional accessory.

### **SPRAYING OTHER LIQUIDS:**

In addition to spraying pesticides, this sprayer may be used to spray other non-flammable liquids. Example uses includes watering plants/trees or spraying water for dust control. However, **WE RECOMMEND THAT THE SPRAYER NOT BE USED FOR OTHER PURPOSES ONCE IT HAS ALREADY BEEN USED FOR SPRAYING PESTICIDES.** Any chemical will leave some residual in the tank liner or sprayer components, even after the sprayer has been properly cleaned. These residual chemicals can have unexpected effects on future uses. For example, spraying water or other liquids that are contaminated with residual pesticide may result in unforeseen hazards to plant or animal life.

**Contact NorthStar Product Support at 1-800-270-0810 for any questions about the appropriate use of the sprayer and/or optional accessories.**

# Summary of Important Safety Information

## **WARNING**

Read and understand **this owner's manual** completely before using the sprayer. Read each **chemical label's instructions** before handling the chemical.

*Improper use of the sprayer or handling of chemicals could result in serious injury or illness for the operator or nearby persons/animals, or cause damage to the environment.*

LISTED BELOW is a summary of safety information of particular importance. See individual sections of this owner's manual for more details.

### ----- DURING ASSEMBLY -----

- **CHECK and TEST completed assembly** as directed in this manual. Serious injury could result from chemical leaks if sprayer is improperly assembled.
- **DO NOT MODIFY sprayer design.**

### ----- DURING OPERATION -----

#### General Chemical Safety

- **READ and FOLLOW** each chemical label's instructions and warnings.
- **AVOID inhaling, ingesting, or coming into contact with any chemicals.**
- **KNOW applicable licensing and regulatory requirements** for the chemical you plan to use.
- **KNOW emergency procedures before handling chemicals.** Carefully review "Chemical Accident Procedures" listed below and later in this manual. Also see First Aid instructions on the chemical label.
- **WEAR protective clothing, eye protection, and chemical resistant gloves** when filling, using and cleaning the sprayer. Wear additional protective gear, such as facemask or apron, as recommended on the chemical label.
- **EXERCISE EXTRA CAUTION around children and pets.** Pesticides are especially toxic to them. Keep sprayer and spray materials away from them at all times.
- **DO NOT MIX OR POUR chemicals in an enclosed, unventilated area**
- **DO NOT USE flammable or corrosive chemicals** in the sprayer.
- **FLUSH the sprayer before switching chemicals** in order to prevent dangerous chemical interactions.
- **STORE pesticides in a correctly labeled container and in a secure location.**
- **MONITOR the health of operators frequently exposed to pesticides**, as recommended by the chemical label or local/federal regulations.

## **DANGER**

Failure to follow the instructions below may result in excessive heat, fire, and/or bursting (explosion), etc.

Do not heat, or place into fire. Do not use, charge, or leave in a hot place.

#### General Electrical Safety

- **READ** owner's manual before using. Failure to follow instructions may result in fire or electric shock.
- **FOR USE ONLY** with NorthStar Li-Ion Battery Pack item #5043106 and NorthStar Charger item #5050015. Using other batteries or chargers may result in fire and/or bursting (explosion).
- **DO NOT** operate in a wet environment or expose to rain.
- **DO NOT** operate in extreme temperatures or expose to fire.
- **DO NOT** charge or use if damaged.
- **DO NOT** drop or impact the battery.
- **DO NOT** disassemble, modify, or repair the battery.
- **DO NOT** allow water to contact the battery terminals or get inside the battery.
- **DO NOT** touch the battery connectors with metal objects or insert metal objects through openings into the battery.
- **DO NOT** store battery in damp location. Doing so can cause a malfunction.
- **IF THE BATTERY LEAKS** fluid or smells strangely, immediately move it away from any heat sources or flame. There is a risk of fire or rupturing if the leaked liquid or gas ignites. Also, if liquid gets into your eyes, rinse them with plenty of water. After that, immediately seek medical care.
- **WHEN BATTERY IS NOT IN USE**, keep away from metal objects, like paper clips, coins, keys, nails, screws, or other small metal objects that can make a connection from one terminal to another. Shorting battery terminals together may cause burns or a fire.

# Summary of Important Safety Information

- **IN CASE OF FIRE**, stop using machine immediately and extinguish with dry chemical, sandy soil, carbon dioxide, or appropriate foam.

## Chemical Application Safety

### Before Spraying

- **INSPECT and PREPARE sprayer before each use** as directed in this manual.
- **DO NOT START sprayer until ready to spray** in order to avoid unintentional spray release.
- **WEAR ADDITIONAL PERSONAL PROTECTIVE EQUIPMENT if you will be spraying overhead.** You will be exposed to much more chemical fallout in these applications. Wear chemical resistant head and neck protection, full face mask or half face mask with sealed goggles and consider using a respirator.
- **DO NOT SPRAY when wind speed exceeds 4 MPH** to minimize spray drift.
- **KEEP sprayer and spray materials away from children/pets.** Pesticides can be especially toxic to children and animals.
- **DO NOT ALLOW anyone younger than 16 to operate sprayer** since pesticides are especially toxic to children.

### During Spraying

- **DO NOT OVERAPPLY pesticide.** Apply at rate recommended by chemical manufacturer. Excess pesticide can be dangerous to humans/animals, damage desirable plants, and contaminate soil and water sources.
- **DO NOT EAT, DRINK, SMOKE, RUB YOUR EYES, or TOUCH YOUR BARE SKIN while handling chemicals and spraying.**
- **NEVER POINT THE SPRAY GUN at people or animals.**
- **DO NOT SPRAY near open flames or sources of heat.**
- **ALWAYS HOLD THE SPRAY GUN FIRMLY when using it to spray at higher pressures** in order to prevent gun from whipping. Always keep good footing and balance.
- **EXERCISE EXTRA CAUTION when spraying near areas accessible to children and pets.**
- **CLEAN up spills immediately** per instructions on the chemical label.
- **TURN OFF vehicle and set brake or block wheels, TURN OFF sprayer, and RELIEVE system pressure** before leaving sprayer unattended.
- **SEE Troubleshooting section of this manual before attempting any repairs.** Wear personal protective equipment and follow safety instructions.

### After Spraying

- **CLEAN sprayer immediately after use** according to the directions provided in this manual.
- **DECONTAMINATE yourself after you are done spraying** and have cleaned the sprayer. Wash all exposed areas of the body with soap and water and remove and launder clothing.
- **DISPOSE OF or STORE remaining chemicals in secure storage with correctly marked container.**

## Transporting Safety

- **READ safety instructions** in your vehicle manual with regard to carrying heavy cargo loads.
- **DISCONNECT battery** and ensure rubber caps/plugs are installed before transporting.
- **DO NOT ALLOW drivers younger than 16** to drive the vehicle with the filled sprayer attached.
- **MAKE SURE SPRAYER IS SECURELY ATTACHED to vehicle.**
- **EXERCISE CAUTION in vehicle handling when driving with filled sprayer** to avoid loss of control or rollover.
  - **Keep speed to a minimum** so you can maintain control. Reduce speed prior to turns.
  - **Allow for more distance to stop.**
  - **Avoid any sudden steering maneuvers, starts, or stops** that could create liquid sloshing in the sprayer and instability.
- **SLOW DOWN and EXERCISE EXTRA CAUTION on sloped or uneven terrain.** Pick the most level route possible across fields--drive up and down slopes when necessary, rather than across. Use a vehicle equipped with a roll over protection system (ROPS) if you will be working on non-level terrain.
- **BE AWARE that visibility may be reduced** when making turns or backing up.
- **DO NOT RIDE or TRANSPORT cargo on the sprayer.**
- **TURN OFF both sprayer and vehicle, and SET BRAKES** before leaving unattended.

# Summary of Important Safety Information

## Chemical accident procedures

Immediate response is necessary in the event of sprayer leaks, bodily chemical contact, poisoning, or spills. See instructions below:

<b>Sprayer leak</b>	<b>If the sprayer develops a leak, <i>immediately stop spraying</i>.</b> Turn off power to the sprayer and follow directions below, as applicable.
<b>Bodily chemical contact</b>	<p><b>Personal contamination can occur when chemicals splash, spill, or spray directly onto a person.</b></p> <p>1. Immediately follow First Aid instructions on <u>chemical label</u>.</p> <p style="padding-left: 40px;"><u>General procedures can include:</u></p> <p style="padding-left: 40px;">a) Eyes – immediately flush with water.  b) Skin – wash all contaminated skin surfaces with soap and water.  c) Clothing – remove contaminated clothing. Dispose of heavily contaminated clothing per chemical label instructions.</p> <p>2. Seek medical advice if instructed on the label or the victim experiences symptoms of harmful effects. Bring the chemical label for reference.</p>
<b>Poisoning by ingestion or inhalation</b>	<p><b>In case of poisoning from ingestion or inhalation:</b></p> <p><i>If the victim has collapsed or is not breathing, call 911.</i> Otherwise:</p> <p>1. If you are the victim, immediately seek assistance from nearby personnel because you may become incapacitated.  2. Immediately follow first aid instructions on <u>chemical label</u>.  3. Call a poison control center for further advice. <b>In the U.S., call 1-800-222-1222.</b> Have the chemical label available for reference.</p>
<b>Chemical spills</b>	<p><b>Chemical spills must be quickly contained and properly cleaned up.</b></p> <p>Refer to the chemical label for any specific clean-up instructions.</p> <p><u>General procedures include:</u></p> <p>1. <b>Controlling</b> the spill by stopping the source of the spill.  2. <b>Containing</b> the spill so that it does not spread and get into water sources.  3. <b>Cleaning up</b> the spill immediately.  4. <b>Seeking additional advice</b> from:  - <u>Chemical manufacturer</u>. See chemical label for contact information.  - <u>State pesticide regulatory agency</u>. In the U.S., call the National Pesticide Info. Ctr. at 800-858-7378 for assistance in contacting your state’s agency.</p>

### ----- DURING STORAGE / TROUBLESHOOTING -----

- **PREPARE THE SPRAYER FOR STORAGE** according to the instructions in this manual.
- **READ and FOLLOW the safety rules for troubleshooting / servicing** the sprayer to avoid accidental exposure to chemical and risk of electric shock.

# Warning Label Location

## ⚠ WARNING ⚠

THIS SPRAYING SYSTEM CONTAINS SOME RV ANTIFREEZE FOR PROTECTION DURING SHIPPING AND STORAGE. RV ANTIFREEZE IS 100% SAFE, NON-TOXIC, AND BIODEGRADABLE.

- CHECK TO MAKE SURE ALL FITTING AND HOSE CONNECTIONS ARE TIGHT BEFORE USE.
- PERFORM A FULL PRESSURE RUN TEST WITH WATER ONLY, AS INSTRUCTED BY THE MANUAL.
- CHECK FOR LEAKS, AND COMPLETELY FLUSH THE SYSTEM BEFORE USING ANY CHEMICALS.

32362

## CAUTION

### Rinse/Flush Unit

Sprayer life will be shortened if these rules are not followed:

- Flush the unit with clean water after each use to clean the chemicals out of the pump, hoses, and spray gun.
- Rinse sprayer off after each use. Corrosive chemicals will shorten the life of the unit if it is not rinsed off.

Part No. 779260

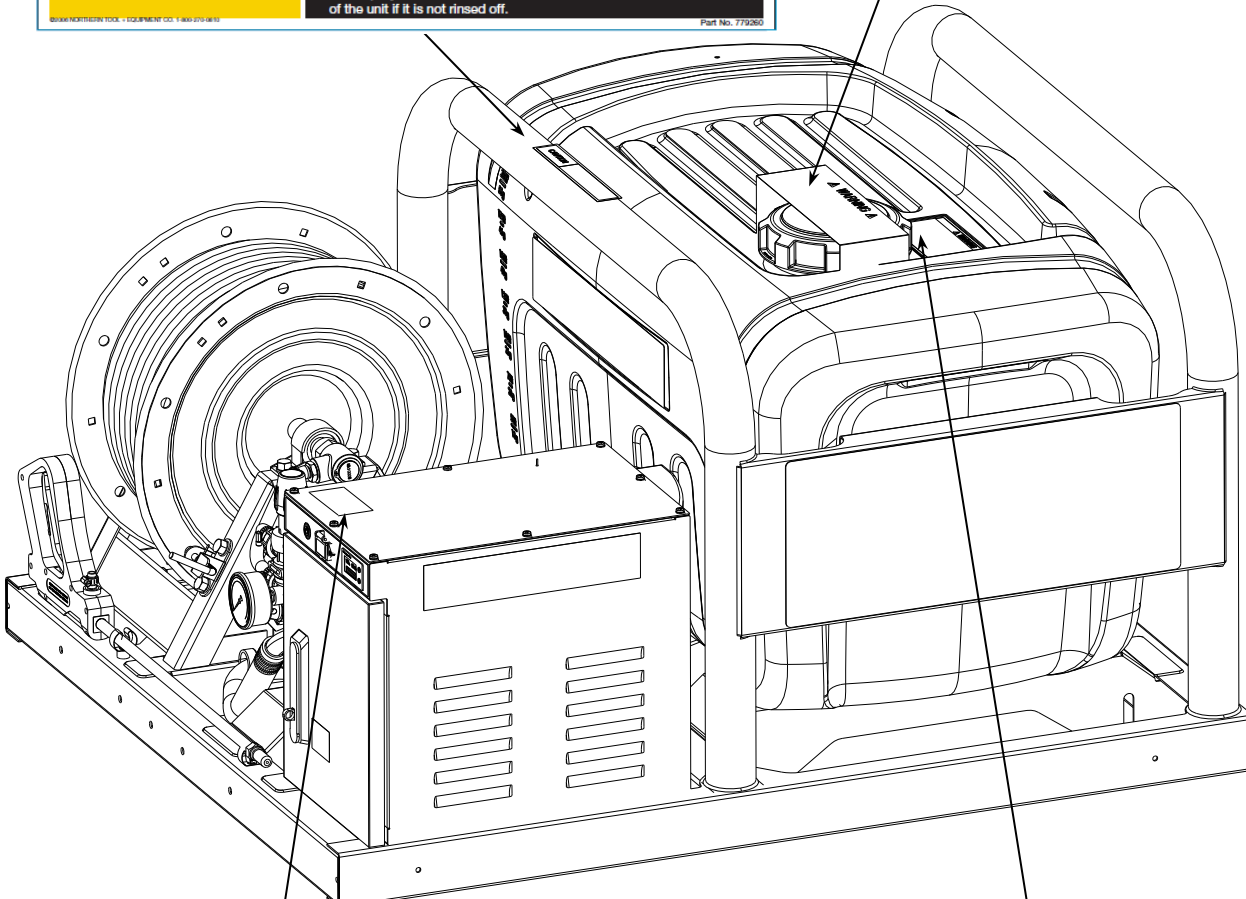

FIG07055

## ⚠ WARNING

- Read owner's manual before using. Failure to follow instructions may result in fire or electric shock.
- For use only with NorthStar Li-Ion Battery Pack item # 5043106 and NorthStar Charger item # 5050015. Using other batteries or chargers may result in fire and/or bursting (explosion).
- Do NOT operate in a wet environment or expose to rain.
- Do NOT operate in extreme temperatures or expose to fire.
- Do NOT charge or use if damaged.

804884

## ⚠ WARNING

READ and UNDERSTAND the Owner's Manual completely before using this sprayer. Assemble, test, and use only in accordance with the Owner's Manual instructions. READ and FOLLOW chemical label instructions. Pesticides are hazardous chemicals which must be handled carefully. KNOW emergency procedures BEFORE handling chemicals. Sprayer leaks, bodily chemical contact, poisoning, and spills are all situations which require immediate response. AVOID inhaling, ingesting, or coming into contact with any chemicals. EXERCISE CAUTION in vehicle handling. Vehicle will be less stable and handle very differently with filled sprayer attached. DO NOT TURN ON power to sprayer until ready to spray in order to avoid inadvertent spray release. DO NOT LIFT sprayer unless tank is empty.

*Improper use of the sprayer or handling of chemicals could result in serious injury or illness to the operator or nearby persons/animals, or could cause damage to the environment.*

Replace this label if damaged or destroyed. Consult Owner's Manual for ordering instructions.

PN 77499

Call 1-800-270-0810 to order new labels.  
 Order Part No. 779260 for Rinse/Flush label  
 Order Part No. 777499 for Chemical label.  
 Order Part No. 32362 for Antifreeze label.  
 Order Part No. 804884 for Product Warning Label.

# Warning Label Location

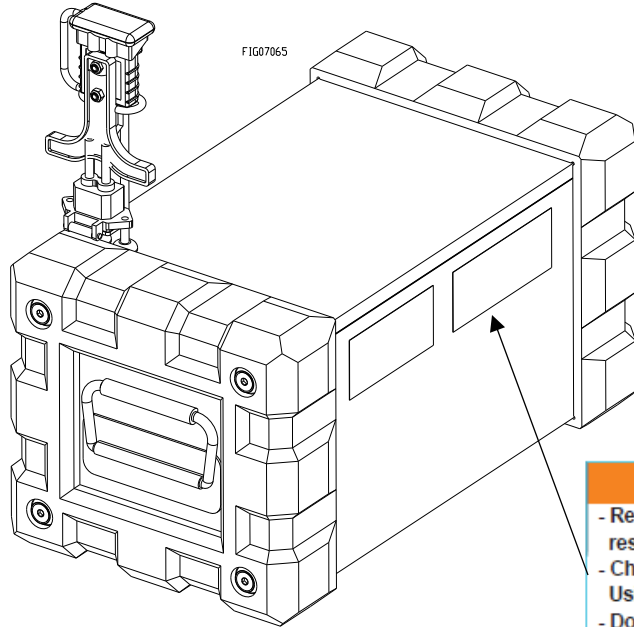

## ⚠ WARNING

- Read owner's manual before using. Failure to follow instructions may result in fire or electric shock.
- Charge only with NorthStar Charger item# 5050015. Using other chargers may result in fire and/or bursting (explosion).
- Do NOT drop, disassemble, modify, crush, pierce, or attempt to repair.
- Do NOT expose to water, fire, or extreme temperatures.
- Do NOT short terminals, may cause burns or a fire.
- Do NOT charge or use if damaged.
- Store indoors in a cool, dry, ventilated environment.

804768

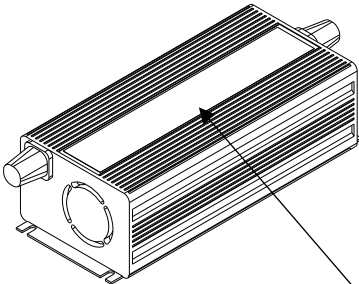

**NORTH  
STAR**  
Proven Performance



## ⚠ WARNING

- Read owner's manual before using. Failure to follow instructions may result in fire or electric shock.
- For use only with NorthStar Li-Ion Battery Pack item# 5043106. Charging other types of batteries may result in fire or bursting.
- Do NOT disassemble, modify or repair.
- Do NOT expose to rain or wet conditions.
- Do NOT use in an enclosed space.
- Do NOT use if cord is damaged.

804766

Call 1-800-270-0810 to order new warning labels.  
Order Part No. 804768 for Battery warning label  
Order Part No. 804766 for Charger label.

# Unpacking

**Closely inspect all contents in the shipping carton.**

If you have missing or damaged components, please contact NorthStar Product Support at 1-800-270-0810.

**The following items are found in the manual bag.**

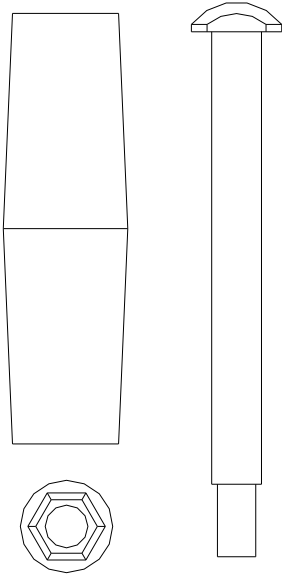

Hose reel handle kit

# Assembly

## **Step One: Attach hose reel handle to the hose reel.**

Attach the hose reel handle to the hose reel with the handle bolt and handle nut.

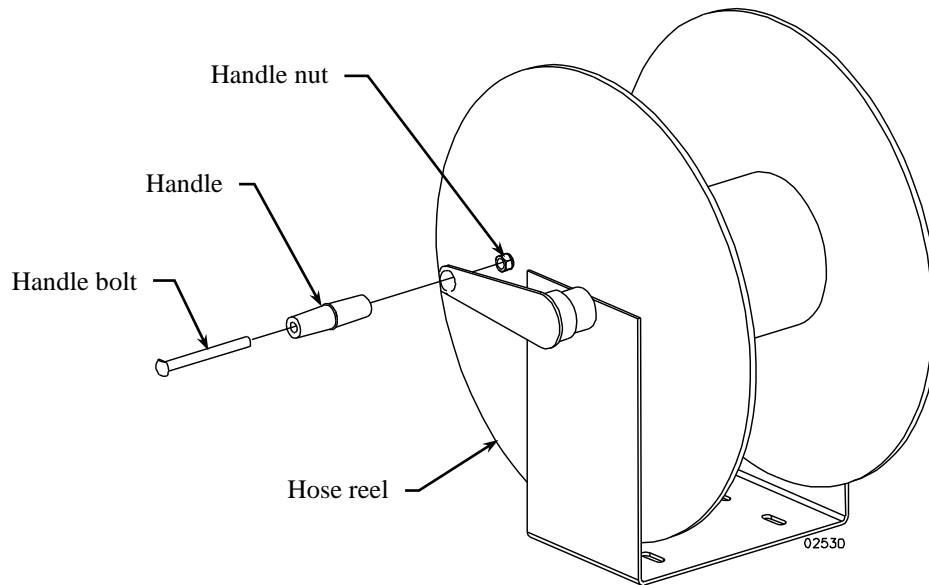

## **Step Two: Attach the sprayer to the vehicle**

Secure the sprayer to the vehicle to prevent the sprayer from shifting during transport.

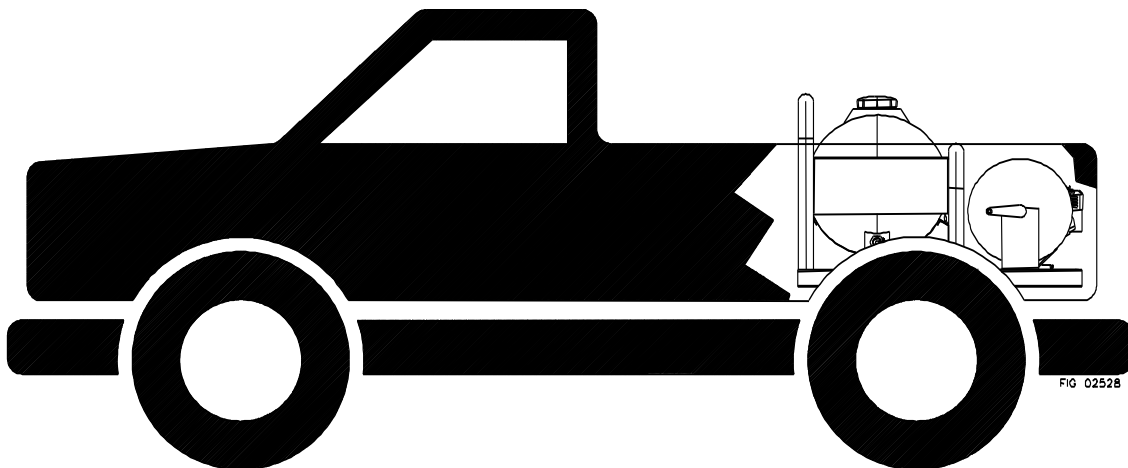

# Assembly

## Step Three: Check and test completed assembly

### ⚠ WARNING

#### Check and test completed assembly

Serious injury could result from chemical leaks if sprayer is improperly assembled, or the design of the sprayer is modified.

Follow the steps below to make sure the sprayer is properly assembled. Never modify the sprayer design.

<b>1. Check assembly</b>	<p><b>Check assembly to make sure the sprayer is properly assembled and in safe working condition:</b></p> <ul style="list-style-type: none"> <li>a) Check that the gun clip screws are tight, hose clamps are secure, and tank straps are properly fastened.</li> <li>b) While it is unlikely that factory assembled components become loose, they should also be checked to make sure they are tight.</li> </ul>
<b>2. Fill tank with water</b>	<p><b>Test the system for leaks with water:</b></p> <ul style="list-style-type: none"> <li>a) First read the instructions in this Owner's Manual for Operation of the sprayer.</li> <li>b) Fill the tank with water per the instructions in this manual. <u>Important:</u> The sprayer should NOT be turned on when you fill the tank.</li> <li>c) Check for leaks throughout the system by operating the sprayer per the instructions in this manual:             <ul style="list-style-type: none"> <li>i) Turn the sprayer ON. (See Operation Instructions)</li> <li>ii) With the agitation valve closed and the spray gun trigger released, adjust the pressure through its full range – to maximum and back. (See Operation Instructions)</li> <li>iii) Open the agitation valve to initiate agitation. (See Operation Instructions)</li> <li>iv) Operate the spray gun. (See Operation Instructions)</li> </ul> </li> <li>d) If a leak is detected, <u>fix the leak and re-test the system with water.</u></li> </ul>

# Machine Components

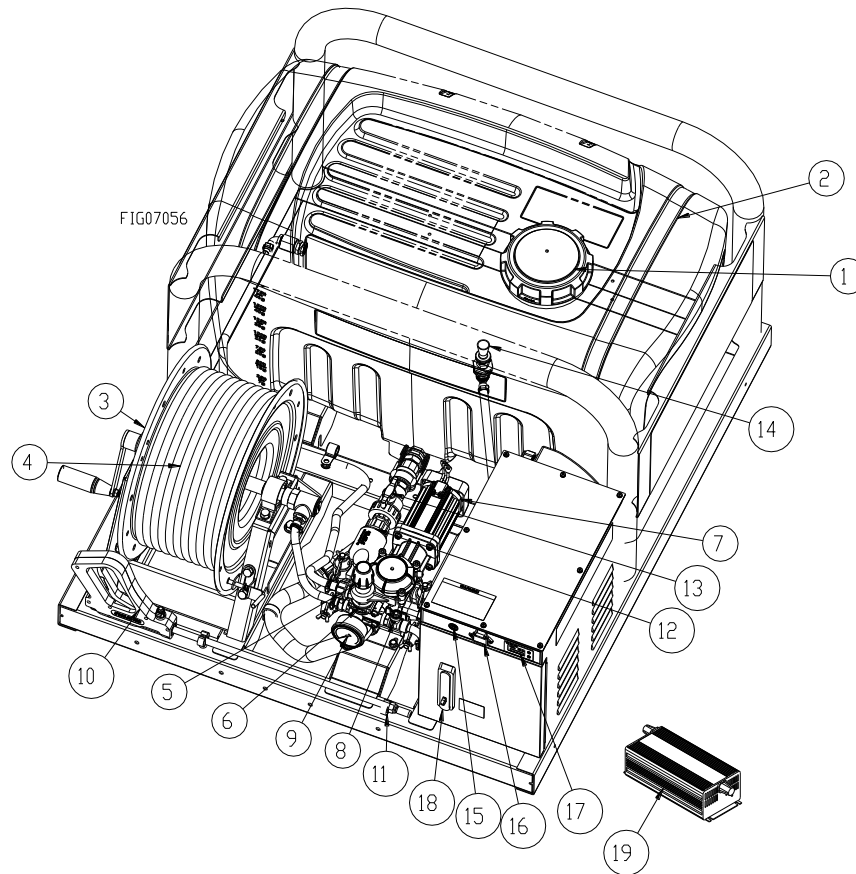

1. **Fill Cap:** The fill cap is vented to allow air to enter the tank as the chemical is used but doesn't allow chemical to escape the tank.
2. **Sprayer Tank:** The sprayer tank holds the chemical.
3. **Hose Reel:** The hose reel is the storage location for the gun hose.
4. **Gun Hose:** The gun hose transfers the chemical from the sprayer to the spray gun.
5. **Pressure Regulator:** Turn the pressure regulator until the sprayer is at the desired pressure. Do not exceed 350PSI.
6. **Pump:** The pump produces the chemical flow.
7. **Motor:** Powers the pump.
8. **Agitation Valve:** Open valve for agitation. Close valve to send all flow to the spray gun.
9. **Pressure Gauge:** The gauge is an indicator of the system pressure
10. **Spray Gun:** Use the spray gun to apply chemical to specific areas.
11. **Gun Clips:** Use the gun clips to store the spray gun.
12. **Suction Strainer:** The strainer prevents debris from entering the pump. It also serves as the tank drain.
13. **Ball Valve:** The ball valve allows strainer filter removal without draining the sprayer tank.
14. **Agitator (inside tank):** The agitator creates a turbulent flow in the tank and keeps chemicals well mixed.
15. **On/Off Switch:** Turns the sprayer on and off.
16. **Charge Port:** Connects the charger to charge battery.
17. **Battery Meter:** Indicates level of battery charge.
18. **Door Latch:** Open and close battery box door, with provision to add optional padlock.
19. **Charger:** Charge battery directly or through battery box charge port in 3.5 hours. Do not charge the battery during operation.

## Operation – Important Safety Information

### WARNING

Carefully read and make sure you understand the following safety information before using the sprayer.

Now that you have completed and tested your assembly, there is some important safety and health information you need to know with regard to handling and spraying chemicals, as well as vehicle handling with the sprayer attached.

### **General Chemical Safety:**

### WARNING

Pesticides are hazardous chemicals.

Heed the warnings below and follow all instructions carefully.

Improper handling of chemicals can result in serious injury or illness, or cause damage to the environment.

- **Chemical label.** ALWAYS READ and FOLLOW all chemical label instructions.
- **Licensing/regulation.** Refer to any applicable licensing restrictions or state/federal regulations with regard to the application of the particular chemical you plan to use.
- **Emergency procedures.** Before handling chemicals, carefully review the “Chemical Accident Procedures” listed later in this section, as well as the “Statement of Practical Treatment” on the chemical label.
- **Inhalation/contact.** ALWAYS take precautions to avoid inhaling or coming into contact with the chemical.
- **Personal protective equipment.** ALWAYS wear protective clothing, eye protection, and chemical-resistant gloves when filling, using and cleaning the sprayer. Wear additional protective gear (such as facemask or apron) as recommended on the chemical label.
- **Children/pets.** Pesticides can be especially toxic to children and animals. ALWAYS exercise extra caution around children. Keep sprayer and all spray materials away from children and animals.
- **Ventilation.** ALWAYS ensure there is adequate ventilation when mixing, pouring, or spraying.
- **Flammables.** NEVER use any flammable chemicals in the sprayer.
- **Corrosives.** DO NOT use corrosive chemicals in the sprayer. They can weaken the sprayer and its parts, resulting in leaks. Check with the chemical manufacturer to ensure chemical is compatible with all components of the sprayer.
- **Chemical interaction.** ALWAYS flush the sprayer before switching chemicals. Different chemicals may interact dangerously with each other.
- **Chemical storage.** ALWAYS store pesticides in a properly labeled container and in a secure location per the manufacturer’s recommendations.
- **Health monitoring.** Monitor the health of operators who are frequently exposed to pesticides, as recommended by the chemical label or local/federal regulations.

## Operation – Important Safety Information

### **WARNING**

Failure to follow the instructions below may result in excessive heat, fire, and/or bursting (explosion), etc.

Do not heat, or place into fire. Do not use, charge, or leave in a hot place.

### **General Electrical Safety:**

- **READ** owner's manual before using. Failure to follow instructions may result in fire or electric shock.
- **FOR USE ONLY** with NorthStar Li-Ion Battery Pack item #5043106 and NorthStar Charger item #5050015. Using other batteries or chargers may result in fire and/or bursting (explosion).
- **DO NOT** operate in a wet environment or expose to rain.
- **DO NOT** operate in extreme temperatures or expose to fire.
- **DO NOT** charge or use if damaged.
- **DO NOT** disassemble, modify, or repair the battery.
- **DO NOT** allow water to contact the battery terminals or get inside the battery.
- **DO NOT** touch the battery connectors with metal objects or insert metal objects through openings into the battery.
- **DO NOT** store battery in damp location. Doing so can cause a malfunction.
- **DO NOT** charge the battery during operation. This can damage the battery.
- **IF THE BATTERY LEAKS** fluid or smells strangely, immediately move it away from any heat sources or flame. There is a risk of fire or rupturing if the leaked liquid or gas ignites. Also, if liquid gets into your eyes, rinse them with plenty of water. After that, immediately seek medical care.
- **WHEN BATTERY IS NOT IN USE**, keep away from metal objects, like paper clips, coins, keys, nails, screws, or other small metal objects that can make a connection from one terminal to another. Shorting battery terminals together may cause burns or a fire.
- **IN CASE OF FIRE**, stop using machine immediately and extinguish with dry chemical, sandy soil, carbon dioxide, or appropriate foam.

# Operation – Important Safety Information

## Chemical Application Safety:

### **WARNING**

Caution must be used when spraying chemicals to avoid unsafe exposure to humans and the environment.

Heed the warnings below and follow all instructions carefully.

#### Before Spraying

- **Sprayer prep.** ALWAYS inspect and prepare the sprayer before use according to the directions provided in this manual.
- **Keep sprayer off.** Do not turn on power to the sprayer until ready to spray in order to avoid unintentional spray release.
- **Wind speed.** NEVER spray when wind speed exceeds 4 MPH in order to minimize spray drift.
- **Clear area/post.** ALWAYS keep the work area clear of people and pets. POST warning notices to restrict access by the public for the period recommended on chemical label.
- **Operator age.** You must be 16 years of age or older to operate this sprayer. Pesticides are especially toxic to children.

#### During Spraying

- **Over application.** DO NOT over apply pesticide. Apply at a rate recommended by chemical manufacturer. Excess pesticide can be dangerous to humans, damage desirable plants, and contaminate soil and water sources.
- **Never point gun.** NEVER point the spray gun at people or animals.
- **Use firm grip.** ALWAYS hold the spray gun with a firm grip when using it to spray at higher pressures in order to prevent gun from whipping. Keep good footing and balance at all times.
- **Children/pets.** ALWAYS exercise extra caution when spraying near areas accessible to children and pets.
- **Eating/smoking.** DO NOT eat, drink, smoke, rub your eyes, or touch any part of your bare skin while handling chemicals and spraying.
- **Heat/flames.** DO NOT spray near open flames or sources of heat.
- **Spills.** ALWAYS clean up spills immediately per instruction on the chemical label.
- **Unattended.** ALWAYS turn off vehicle and set brake or block wheels, turn off power to sprayer, and relieve system pressure before leaving sprayer unattended.
- **Troubleshooting.** ALWAYS refer to the safety instruction in the Troubleshooting Section before attempting any repairs.

#### After Spraying

- **Clean sprayer.** ALWAYS clean the sprayer immediately after use according to the directions provided in this manual.
- **Decontaminate.** ALWAYS decontaminate yourself immediately after you are finished spraying and handling chemicals. Wash all exposed areas of the body with soap and water and remove and launder clothing.
- **Chemical disposal/storage.** ALWAYS dispose of or store remaining chemicals properly as recommended on the chemical label.

# Operation – Important Safety Information

## Transporting Safety:

### ⚠ WARNING

Serious injury can occur if the vehicle on which the sprayer is mounted is driven unsafely.

- **Read vehicle instructions.** Review safety instructions in your vehicle manual with regard to carrying heavy cargo loads.
- **Disconnect** battery and ensure rubber caps/plugs are installed before transporting.
- **Driver age.** You must be 16 years of age or older to drive the vehicle with the filled sprayer attached.
- **Vehicle handling.** Be aware that vehicle handling will be affected when driving with the filled sprayer. Exercise caution to avoid loss of control or rollover:
  - **Keep speed to a minimum** so you can maintain control at all times. Reduce speed prior to turns.
  - **Allow for more distance to stop.**
  - **Avoid any sudden** steering maneuvers, starts, or stops that could create liquid sloshing in the sprayer and instability.
- **Rough or sloped terrain.** Slow down and exercise extra caution on rough or sloped terrain in order to reduce risk of rollover. Pick the most level route possible when transporting across fields. Drive up and down slopes that cannot be avoided, rather than across. Use a vehicle equipped with a Roll Over Protection System (ROPS) if you will be operating on non-level terrain.
- **Reduced visibility.** Be aware that visibility may be reduced with sprayer attached. Be extra cautious when backing up or turning.
- **Ride / transport.** Never ride or transport cargo on the sprayer.
- **Under the influence.** Never transport or operate this sprayer while under the influence of alcohol, drugs, or medication
- **Unattended.** Before leaving the sprayer unattended, turn off both the vehicle and sprayer, and set vehicle brakes.

## Chemical accident procedures:

### ⚠ WARNING

Before you fill the sprayer, review the following information with regard to handling accidents. Chemical spills, sprayer leaks, personal contamination, and poisoning are accident situations that you may encounter. **All require an immediate response – See instructions below.**

<b>Sprayer leak</b>	<p><b>In the event that the sprayer develops a leak while spraying chemicals, you must <i>immediately stop spraying.</i></b></p> <p style="padding-left: 40px;">Turn off the sprayer and follow the directions below, as applicable.</p>
<b>Bodily chemical contact</b>	<p><b>Personal contamination can occur when chemicals splash, spill, or spray directly onto a person.</b></p> <p>1. Follow the emergency first aid instructions on the chemical label listed in the “First Aid” or “Statements of Practical Treatment” section.</p> <p><u>General procedures include:</u></p> <p>a) Eyes – immediately flush with water or follow other directions as specified on the chemical label.</p> <p>b) Skin – immediately wash all contaminated skin surfaces with soap and water, or follow directions as specified on the chemical label.</p>

## Operation – Important Safety Information

	<p>c) Clothing – remove contaminated clothing immediately. Dispose of heavily contaminated clothing per the instructions on the chemical label for safe chemical/container disposal.</p> <p>2. Seek medical advice if instructed on the label, or if the victim experiences symptoms of harmful effects such as burning, swelling, nausea, chest pain, difficulty breathing, dizziness or confusion. When seeking medical advice, be sure to bring the chemical product label.</p>
<b>Poisoning by ingestion or inhalation</b>	<p><b>In case of poisoning from ingestion or inhalation:</b></p> <p>IF THE VICTIM HAS COLLAPSED OR IS NOT BREATHING, <b><u>CALL 911</u></b>.</p> <p>Otherwise:</p> <ol style="list-style-type: none"> <li>1. If you are the victim, immediately seek assistance from nearby personnel because you may become incapacitated.</li> <li>2. Follow the emergency first aid instructions on the chemical label in the “First Aid” or “Statement of Practical Treatment” section.</li> <li>3. Call a poison control center for further advice. <b>In the U.S., call 1-800-222-1222 to be automatically linked to the nearest certified poison control center.</b> Have the chemical label available for reference.</li> </ol>
<b>Chemical spills</b>	<p><b>Chemical spills must be quickly contained and properly cleaned up.</b></p> <p>Refer to the chemical label for any specific clean-up instructions with regard to the chemical spilled.</p> <p><u>General procedures include:</u></p> <ol style="list-style-type: none"> <li>1. <b>Control</b> the spill by stopping the source of the spill. If the source of the spill is a container leak, place the leaking container in a larger, watertight container. Keep unprotected people away from the spill site.</li> <li>2. <b>Contain</b> the spill so that it does not spread and get into water sources. Use a shovel or other tool to make a dike around the spill with soil, sod, or absorbent material.</li> <li>3. <b>Clean up</b> the spill immediately -- Absorbent materials like ground corncobs or pet litter should be spread on the spill area to soak up the pesticide. The contaminated material should then be shoveled into a leak proof container. Do not flush the spill area with water until you receive advice as directed below.</li> <li>4. <b>Seek additional advice</b> from the chemical manufacturer and your state’s pesticide regulatory agency regarding decontamination of the spill site:             <ul style="list-style-type: none"> <li>- <i>Chemical manufacturer.</i> The chemical label provides contact information for the chemical manufacturer.</li> <li>- <i>State pesticide regulatory agency.</i> In the U.S., call the National Pesticide Information Center at 1-800-858-7378 for assistance in determining how to contact your state’s pesticide regulatory agency.</li> </ul> </li> </ol>

# Operation – Preparing the Sprayer for Each Use

## Step One: Inspect/Repair

If the sprayer has been used previously, it must be prepared BEFORE EACH SUBSEQUENT USE.

### ⚠ WARNING

Read instructions below carefully for inspecting and preparing the sprayer. Damaged or clogged equipment could result in leaks or uncontrolled spray. Leaks could result in injury to the operator or bystanders from chemical exposure, or cause damage to the environment.

### Important safety rules:

- **Power off.** Make sure all power is OFF and battery is disconnected before cleaning, inspecting, or servicing the sprayer.
- **Guards / shields.** Make sure all guards and shields are replaced after servicing the sprayer.
- **Replacement parts.** If a part needs replacement, only use parts that meet the manufacturer’s specifications. Replacement parts that do not meet specifications may result in a safety hazard or poor operation of the sprayer.

<b>1. Ensure sprayer attached</b>	<b>Ensure the sprayer is securely attached to vehicle.</b>
<b>2. Ensure tank empty</b>	<b>Ensure the sprayer has been thoroughly flushed and drained of all residual chemical from prior uses.</b>

**3. Clean suction strainer**  
**Clean the suction strainer of any chemical residue.**  
 It is important to clean the suction strainer before each use to ensure it is not clogged and to prevent residual chemical from contaminating sprayer contents.

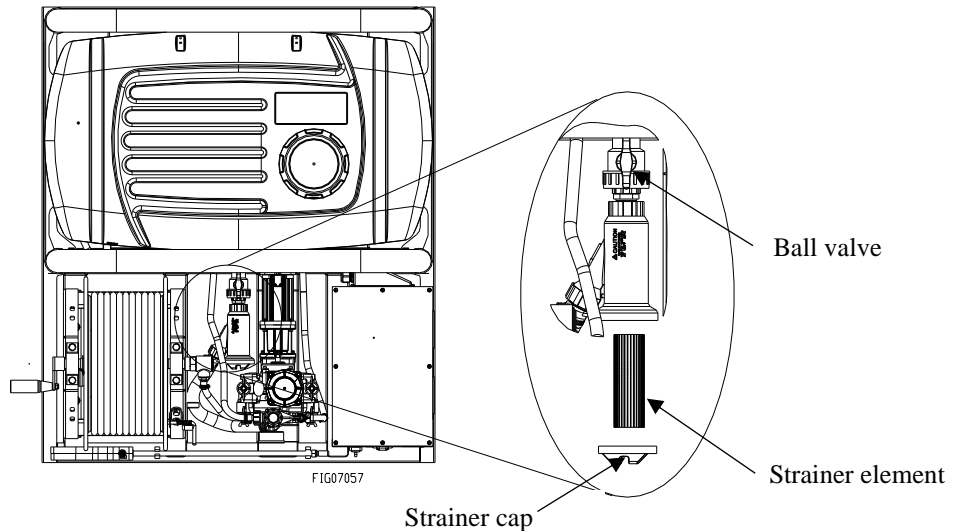

**Directions:**

- a) Close the ball valve.
- b) USING CHEMICAL RESISTANT GLOVES, unscrew the strainer cap and remove the strainer element.
- c) Run the strainer element under fresh water to remove debris.
- d) Replace the strainer element and reinstall the strainer cap.
- e) Open the ball valve.

*NOTE: It is not unusual for the operator to be exposed to chemical residue while cleaning the strainer—wear chemical resistant gloves.*

# Operation – Preparing the Sprayer for Each Use

## 4. Inspect & repair

### Inspect and test the sprayer thoroughly

- a. Inspect hoses for exposed mesh and holes. Replace all worn or damaged hoses.
- b. Inspect fittings for cracks and leaks. Replace all damaged fittings with original NorthStar parts.
- c. Inspect tank for cracks.
- d. Check to be sure all nuts, bolts, and screws are tight.
- e. Ensure tank straps are snug.
- f. Check oil levels in pump and gearbox. See pump owner’s manual.
- g. Partially fill tank with plain water and spray to test for leaks. Repair as needed.

**IMPORTANT:** After any repair work has been done, ALWAYS test for leaks with water one final time before using.



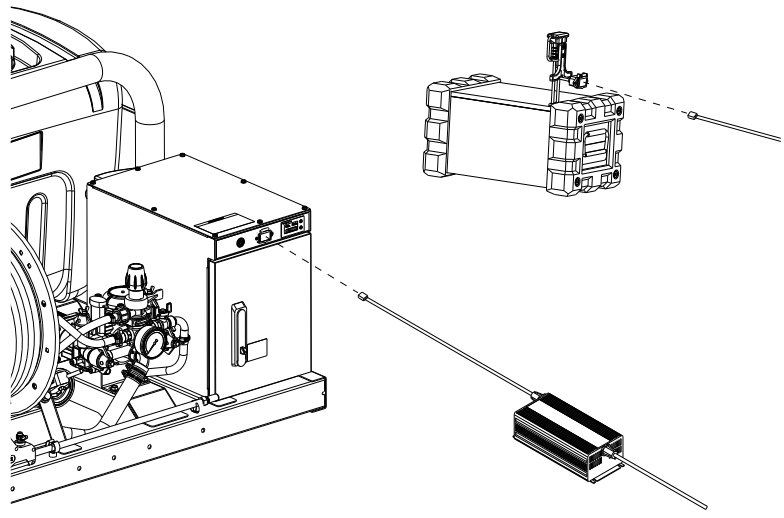

## 5. Charge battery

**Plug charger into battery or battery box (if battery is already installed in battery box, if not see step 6 to install).** See charger manual for more detail.

**ONLY USE** NorthStar Charger item #5050015. Using other chargers may result in fire and/or bursting (explosion). Do not charge the battery during operation. This can damage the battery.



### Charger indicator lights:

			
Solid Green Fully Charged	Solid Red Charging	Blinking Red Battery Fault	Blinking Red/Green Overheated

# Operation – Preparing the Sprayer for Each Use

## 6. Install and connect battery

- a. Ensure main power switch on the battery box control panel is in the Off position.

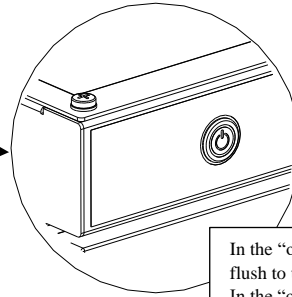
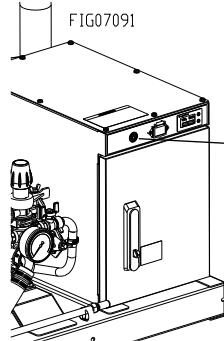

In the "off" position, the switch button is flush to the control panel surface.  
In the "on" position, the switch button is recessed into the panel.

- b. Open battery enclosure door by lifting and rotating the handle.

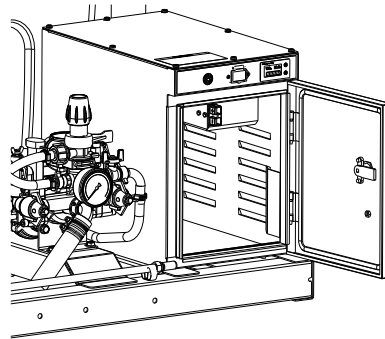

- c. Using both carry handles, place the end of the battery pack opposite the power plug just inside the battery box enclosure.

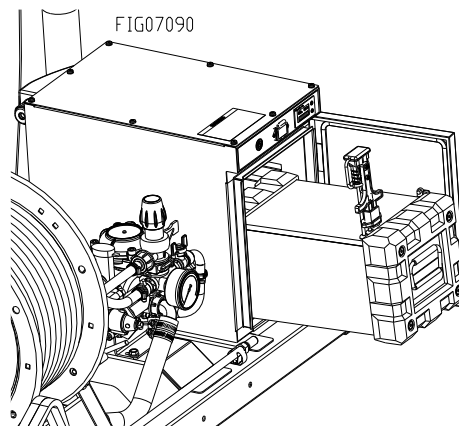

- d. Make sure all wires and terminals are hanging over the outside end of the battery pack so they do not get pinched or damaged.

## Operation – Preparing the Sprayer for Each Use

- e. Slide the battery pack into the battery box until it reaches the back of the battery box. The front of the battery pack should be resting on the bottom of the battery box just inside the door.

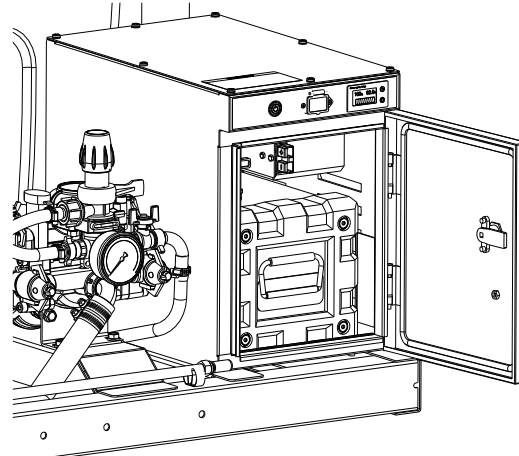
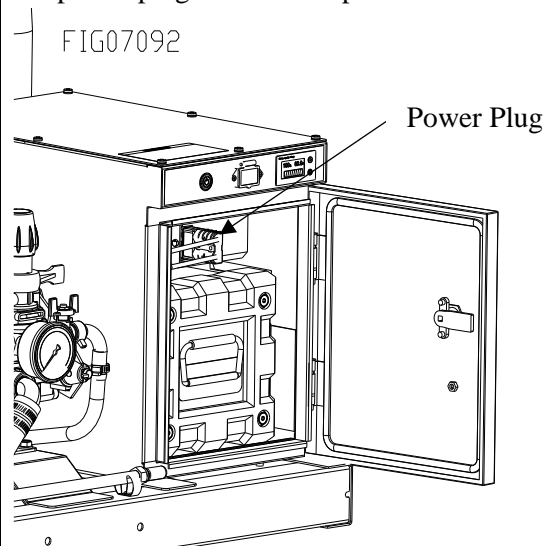

FIG07072

- f. Remove the power plug cover and use the power plug handle to insert the power plug into the receptacle mounted inside the battery box.



- g. Close and latch the battery box door.

# Operation – Using the Sprayer

## **Step One: Assess wind conditions and clear work area.**

Before you decide to spray, you must determine whether wind conditions are suitable. You must also restrict access to the work area to ensure the safety of bystanders.

### **⚠ WARNING**

Do not spray if wind speeds are greater than 4 MPH or if there are bystanders in the intended spray area.

<b>1. Assess wind speed</b>	<p><b>Assess weather conditions to ensure that it is not too windy to spray.</b></p> <p><b>DO NOT SPRAY if wind speeds are greater than 4 MPH.</b></p> <p><i>Visible indication of wind speed:</i></p> <p>If leaves are in constant motion or there is any branch movement, DO NOT spray because the wind is too strong.</p>
<b>2. Clear work area</b>	<p><b>Clear the work area of all bystanders and pets.</b></p> <p>Restrict access by the public for the period recommended on chemical label.</p>

## **Step Two: Check and set accumulator pressure.**

Using an air pressure gauge, check the pressure in the accumulator. The accumulator dampens water pulsations created by the pump's diaphragms. This provides smoother water delivery to the nozzle. The accumulator's pressure must be adjusted according to the operating pressure. See table below.

Pump Operating Pressure	Accumulator Inflating Pressure
PSI	PSI
29-73	29
73-145	29-73
145-363	73-102

Locate the pressure valve on the accumulator, and:

1. Check the pressure in the accumulator with an air pressure gauge.
2. Add or remove air and recheck with air pressure gauge to achieve correct pressure.

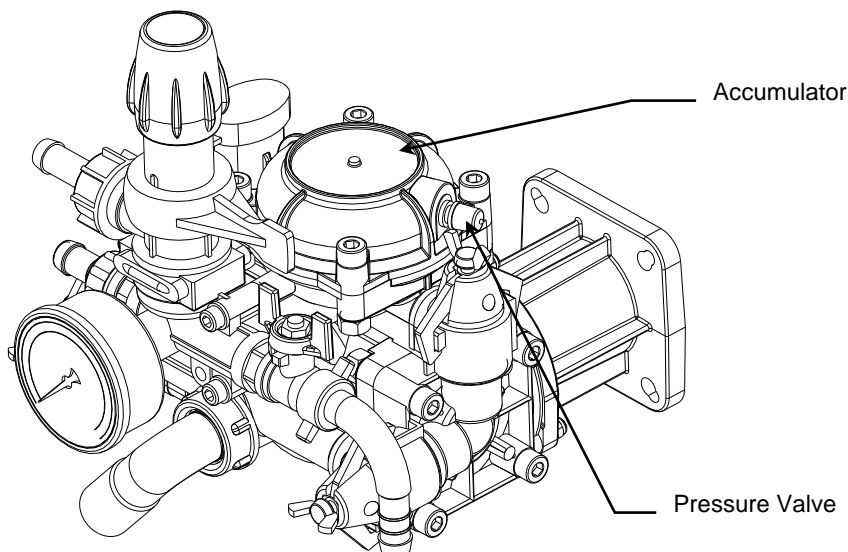

# Operation – Using the Sprayer

## Step Three: Fill the sprayer.

### ! WARNING

ALWAYS wear personal protective equipment as directed on the chemical label when handling pesticides.

Long pants and sleeves, chemical resistant gloves, and eye protection are strongly recommended. Additional protective gear may be required depending on the particular pesticide.

### Fill the sprayer using the following steps:

<b>1. Review safety information</b>	<b>Review the “Operation – Important Safety Information”</b> related to <u>General Chemical Safety</u> and <u>Chemical Accident Procedures</u> provided in this manual.
<b>2. Choose safe mixing/loading area</b>	<b>Choose a safe pesticide mixing and loading area.</b> - Choose an outdoor, well-ventilated area away from unprotected people, animals, food, and other items that might become contaminated.
<b>3. Wear personal protective equipment</b>	<b>Wear personal protective equipment as directed on the chemical label.</b> - Note that additional equipment may be specified for mixing and loading activities.
<b>4. Turn off sprayer and vehicle</b>	<b>Turn OFF the sprayer before filling.</b> - The vehicle should also be off, with brake set or wheels blocked to prevent unintended movement.
<b>5. Remove fill cap</b>	<b>Remove the fill cap located on top of the sprayer.</b>
<b>6. Ensure tank flushed</b>	<b>Ensure tank is flushed of all chemicals from prior uses.</b> - Chemicals can interact dangerously when mixed, and residue chemicals are also a health hazard. - To flush the tank the strainer cap has to be removed and the suction line ball valve has to be opened.

**7. Check strainer cap**      **Ensure strainer cap is securely fastened.**

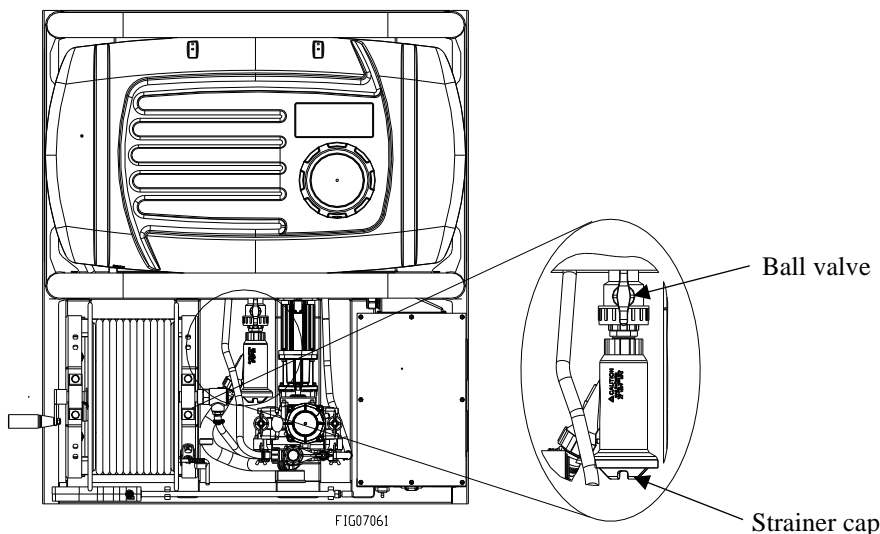

# Operation – Using the Sprayer

**8. Fill tank**

**Add pesticide to tank through fill cap:**

- a) Confirm the chemical/water dilution ratios specified on the chemical label.
- b) Determine chemical and water volumes needed for the planned application, taking into consideration that maximum tank capacity is 55 gallons.

*Note: Only purchase and mix as much chemical as you need for the planned application in order to minimize chemical over application and the need for storing unused chemicals.*

- c) Add chemical to the tank through the fill cap.

*If the chemical is not pre-mixed, add water and pesticide concentrate in the order prescribed on the label.*

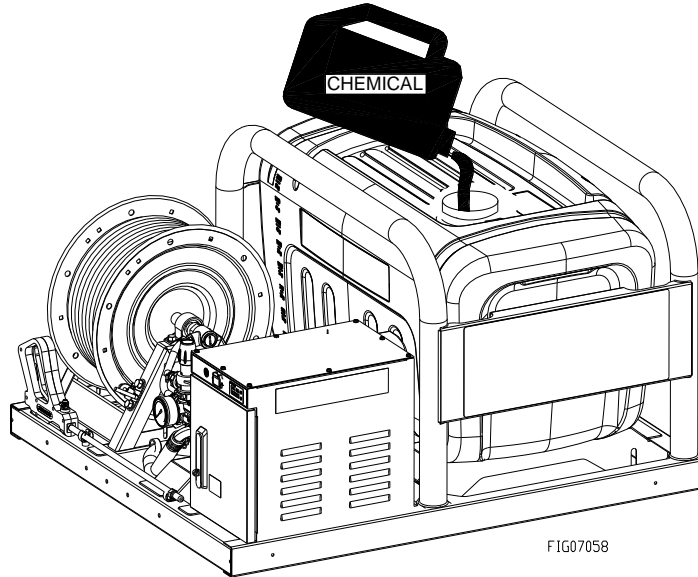

**8. Ensure chemical mixed**

**Ensure chemical is thoroughly mixed in tank.**

- Stirring device should be made of metal or plastic, non-chemical absorbing material, and then properly cleaned and stored after use.

**9. Replace fill cap**

**Replace fill cap and tighten securely.**

# Operation – Using the Sprayer

## Step Four: Operate the sprayer.

### **⚠ WARNING**

ALWAYS wear personal protective equipment as directed on the chemical label when spraying. Long pants and sleeves, chemical-resistant gloves, and eye protection are strongly recommended. Additional protective gear may be required depending on the particular pesticide.

<b>1. Review safety information</b>	Review the “ <b>Operation – Important Safety Information</b> ” related to <u>Chemical Application Safety</u> and <u>Transportation Safety</u> provided in this manual.
<b>2. Wear personal protective equipment</b>	Wear personal protective equipment as directed on the chemical label.
<b>3. Open ball valve</b>	Open the suction line ball valve.

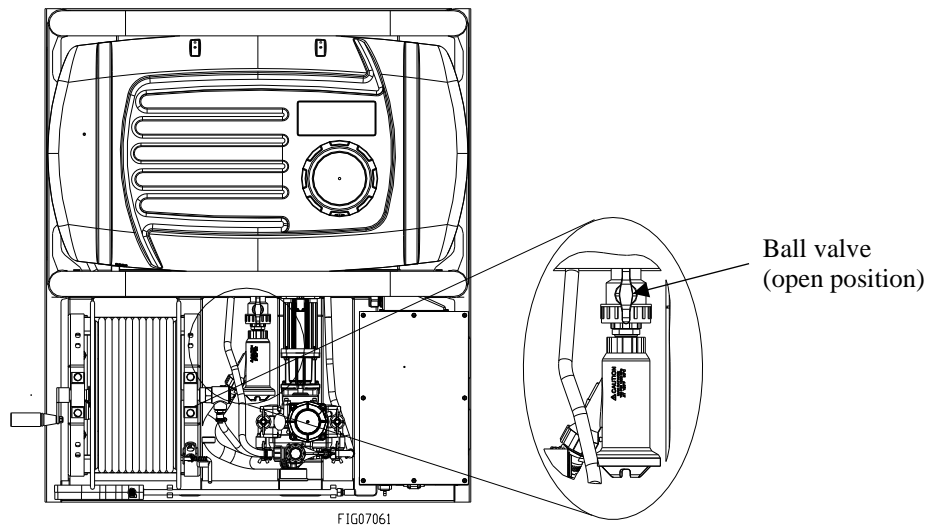

## Operation – Using the Sprayer

**5. Rotate bypass lever to start**

**Rotate the bypass lever to the START position.**

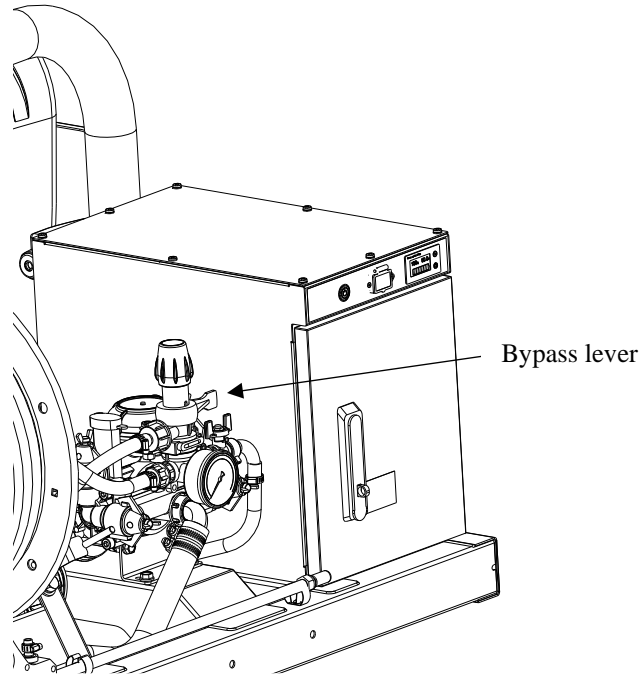

**6. Start motor**

**Turn the power switch ON**

**7. Rotate bypass lever to run**

**Rotate the bypass lever to the RUN position.**

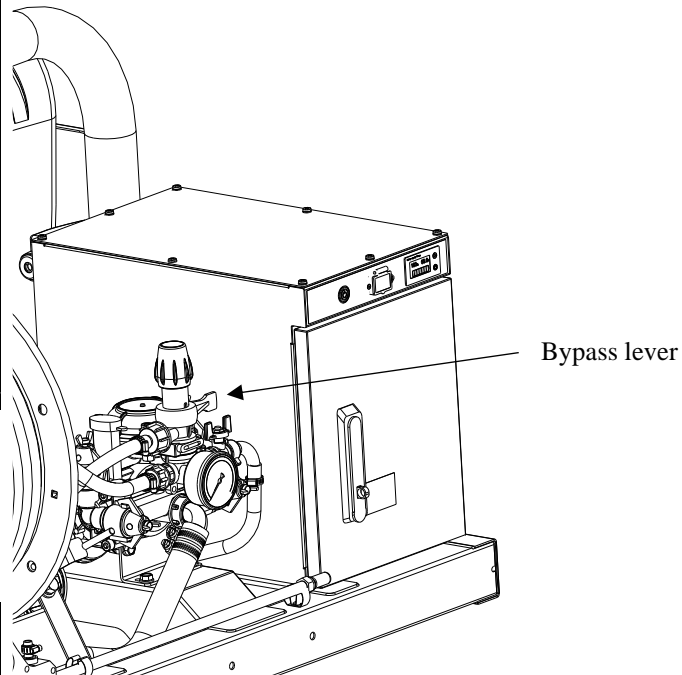

## Operation – Using the Sprayer

### 8. Begin agitation if needed

- 1. Decide if agitation is required. Some formulations of liquid pesticides do not remain in solution and should be agitated to maintain a uniform mix.**

This sprayer is equipped with an *agitator* that should be used when spraying pesticides classified as “flowable” (“F” or “L”), “wetable powder” (“WP” or “W”), “emulsion” (“EC” or “E”), “microencapsulated” (“M”), or water dispersible granules (“WDG” or “DF”). (See pesticide label to determine its classification.)

- 2. Operation principle:**

The nozzle design creates a venturi effect, speeding up the fluid flow as it exits the nozzle. This increase in velocity creates a low-pressure area (vacuum) which draws in additional fluid from the tank, multiplying the outlet flow for increased agitation.

- 3. Operate the agitator**

Begin agitation by opening the agitation valve.

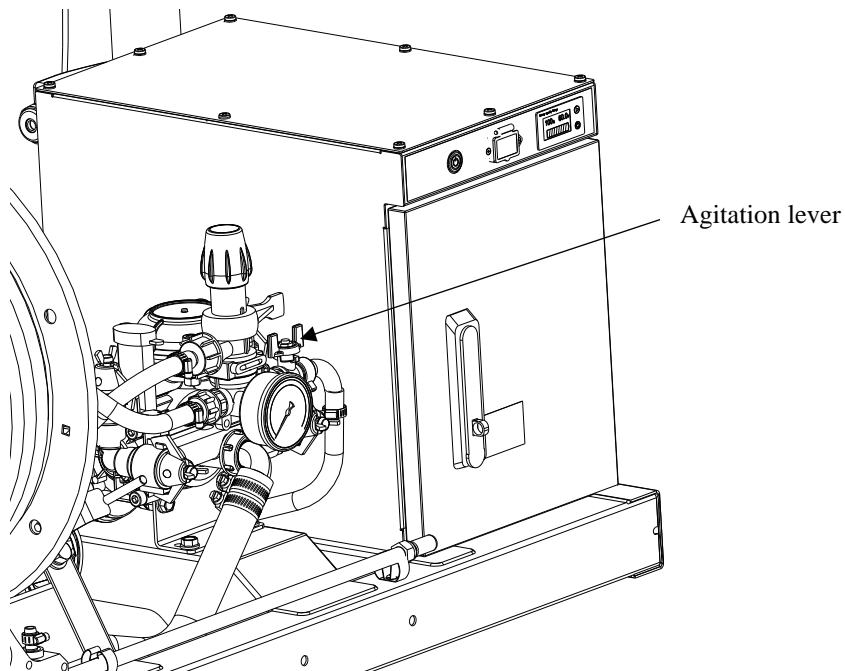

### 9. Adjust pressure as needed

- Turn the pressure regulator until desired pressure is achieved. Turn clockwise to increase pressure, counterclockwise to decrease pressure. Do not exceed 350psi.**

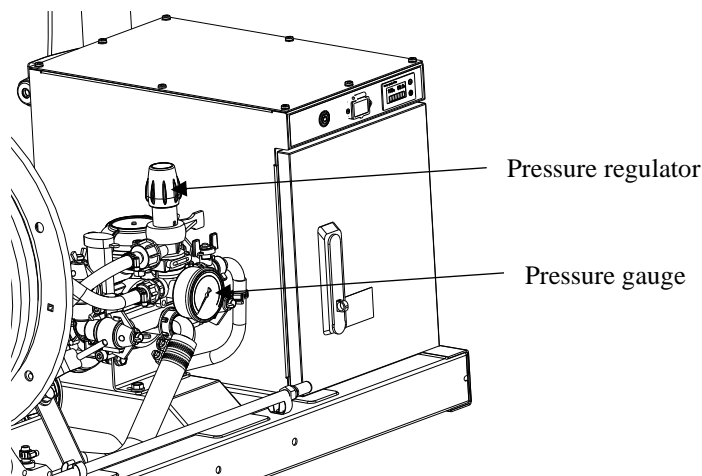

## Operation – Using the Sprayer

**10. Operate spray gun (as needed for application)**

**Proper Operation of the Spray Gun.**

1. Squeeze the handle to begin spraying.

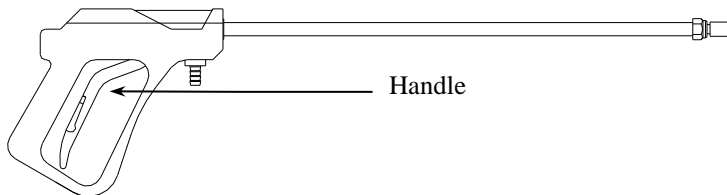

**IMPORTANT:** ALWAYS hold the spray gun with a firm grip when spraying at higher pressures to prevent gun from whipping. Keep good footing and balance at all times.

**NOTE:** It is not unusual for the operator to be exposed to chemical while operating the spray gun—gloves should be chemical resistant.

**11. Leaving unattended**

**If the sprayer must be left unattended at any time:**

- a) Turn off power to the sprayer and disconnect battery.
- b) Relieve system pressure by depressing the gun trigger.
- c) Turn off the vehicle. Set brake or block the wheels.

**12. Discontinue use if clogged or inoperative**

**If the sprayer becomes clogged or inoperative during use, *discontinue use immediately.***

- DO NOT attempt to service while chemicals are in the sprayer and motor is on.
- Return to service area to review instructions for troubleshooting before attempting to service.

*Note: A reserve, clean container capable of holding at least 55 gallons should be kept for use when the sprayer tank needs to be emptied temporarily for repairs. It is advisable to purchase a reserve tank suitable for pesticide storage from Northern Tool and Equipment for use in these circumstances. The container should be properly labeled as to its contents if it is used.*

# Operation – Using the Sprayer

## **Step Five: Clean sprayer and decontaminate after use.**

When done using the sprayer, it is important to clean the sprayer and decontaminate yourself. Do not store the sprayer with chemicals in the tank, as it is unsafe and could also result in damage to the equipment.

### **⚠ WARNING**

Clean-up and decontamination procedures must be followed after each use.

Improper equipment clean-up and disposal of chemicals can result in dangerous chemical exposure to humans and the environment, as well as equipment damage.

Personal decontamination is required after spraying to minimize unsafe exposure to chemicals and potential illness.

### **1. Drain tank**

#### **If there is excess pesticide left in tank, drain the tank.**

- a) Turn off the sprayer and relieve system pressure by operating the spray gun.
- b) Find a suitable container in which to drain the unused pesticide. Place it under the strainer cap.
- c) While wearing rubber gloves, eye protection, and all other required personal protective equipment, close the suction line ball valve and remove strainer cap and strainer element.
- d) Open suction line ball valve and drain tank into the suitable container.
- e) When tank stops draining, replace strainer element and tighten strainer cap securely.

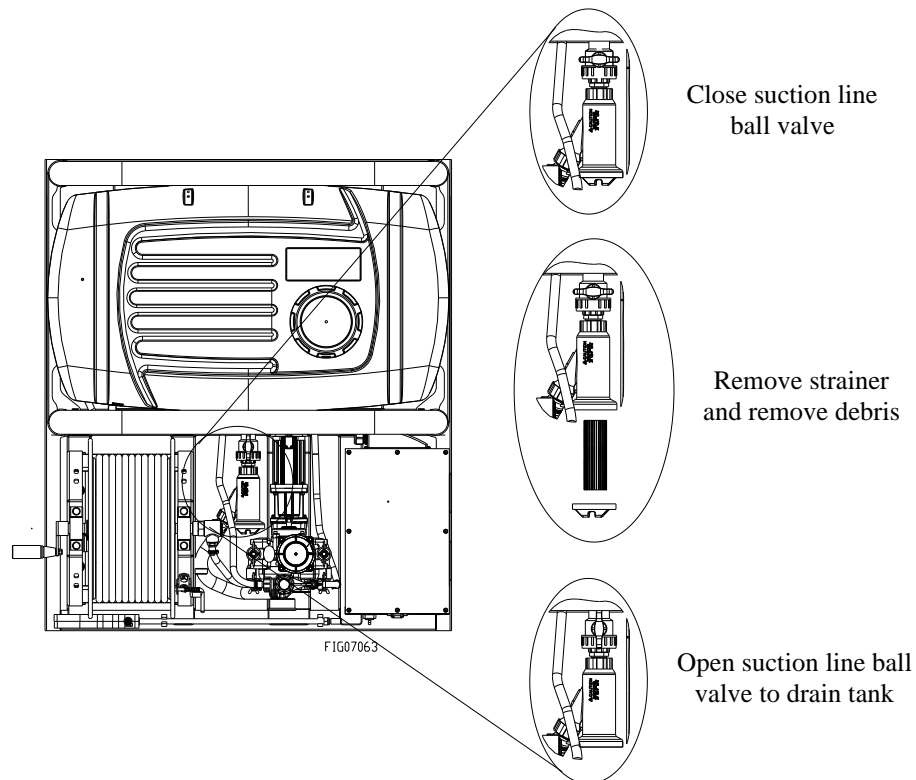

## Operation – Using the Sprayer

<b>2. Unused chemical</b>	<p><b>Properly store or dispose of unused chemical:</b></p> <p>a) <u>If the unused pesticide is to be stored for future use:</u> Store all unused pesticide in its original, or a suitably marked, container in a secure location out of the reach of children &amp; animals.</p> <p>b) <u>If remaining pesticide is to be disposed:</u> Properly dispose of the remaining chemical and its container per the chemical manufacturer's recommendation and according to local hazardous waste disposal regulations.</p>
<b>3. Flush sprayer</b>	<p><b>Flush the sprayer per the chemical manufacturer's recommendations.</b> A general procedure is as follows:</p> <p>a) Add fresh water to the tank.</p> <p>b) Start the motor.</p> <p>c) Operate the spray gun and discharge all rinse water onto an area that can accept dilute pesticide application.</p> <p>d) Add 5 gallons of the chemical manufacturer's recommended cleaning solution. Operate the spray gun, collecting the discharged solution if recommended by the manufacturer.</p> <p>e) After flushing, turn off the motor and be sure all system pressure is relieved by operating the gun.</p> <p>f) Dispose of cleaning solution discharge as recommended by the manufacturer of the solution.</p>
<b>4. Decontaminate &amp; launder</b>	<p><b>Decontaminate yourself after you are finished handling chemicals:</b></p> <p>a) Remove all clothing worn during spraying and chemical handling.</p> <p>b) Wash all exposed parts of the body with soap and water.</p> <p>c) Launder clothing separately from other wash.</p>

## Storage

Prepare the sprayer for end-of-season storage by running RV antifreeze through the system. This will keep internal parts lubricated, protect against corrosion, and keep the unit from freezing.

### CAUTION

The sprayer will be damaged if it freezes.

Protect the sprayer from freezing during storage by following the instructions below.

#### **Preparing for storage:**

<b>1. Add antifreeze</b>	<p>Pour 2 gallons of RV antifreeze into the tank.</p> <p><i>NOTE: RV antifreeze is non-toxic and biodegradable and generally safer for the environment than automotive antifreeze.</i></p>
<b>2. Spray briefly</b>	<p>Start the sprayer and squeeze the gun trigger briefly until fluid sprays.</p>
<b>3. Charge battery and store indoors</b>	<p><b>Plug charger into battery or battery box (if battery is installed in battery box).</b></p> <p>Once fully charged, bring battery inside for storage.</p> <ol style="list-style-type: none"> <li>1. Store the battery indoors in a cool, dry, ventilated environment.</li> <li>2. Unplug the battery from the charger.</li> <li>3. Keep the battery's charge above 50%. Charge the battery at least once every three months.</li> <li>4. Do not stack items on top of the battery.</li> <li>5. Inspect the battery and wires for any damage prior to use.</li> </ol>

#### **Removing from storage:**

<b>1. Drain</b>	<p>Drain the antifreeze left in tank. (See cleaning section of Operation Instructions.)</p>
<b>2. Flush with water</b>	<p>Fill the tank with fresh water and run through the system. Operate the spray gun until the system is completely flushed. Be sure to set up containers to capture the antifreeze flush water.</p>
<b>3. Disposal</b>	<p>Dispose of the antifreeze and flush water properly.</p>

# Troubleshooting

## ⚠ WARNING

Before troubleshooting or attempting to service, read the following safety rules to avoid accidental exposure to chemical and also risk of electric shock.

*Note: A reserve, clean container capable of holding at least 55 gallons should be kept for use when the sprayer tank needs to be emptied temporarily for repairs. It is advisable to purchase a reserve tank suitable for pesticide storage from Northern Tool and Equipment for use in these circumstances. The container should be properly labeled as to its contents if it is used.*

### **Before attempting to service the sprayer:**

<b>1. Personal protective equipment</b>	<b>Wear personal protective equipment as directed on the chemical label while servicing your sprayer.</b>
<b>2. Review troubleshooting table</b>	<b>Review the Troubleshooting Table below for the type of problem you are experiencing.</b> However, DO NOT attempt to repair until the steps listed below are followed.
<b>3. Empty and flush</b>	<b>If the cause listed for your problem is Clogged intake tube, Clogged suction strainer, or Worn spray gun nozzle:</b> empty the tank and flush the sprayer with water as directed in the section, “Operation – Step Four”.  <i>- In order to avoid accidental exposure to chemicals, never attempt to unclog the intake tube or suction strainer, or service the spray gun nozzle, until the tank has been emptied and the sprayer flushed with water.</i>
<b>4. Disconnect power/relieve pressure</b>	<b>Stop the motor and be sure all system pressure is relieved by operating the spray gun. Disconnect battery and install rubber cover over terminals.</b>
<b>5. Perform repairs</b>	<b>Follow the directions provided in the troubleshooting table to repair the sprayer.</b>  <i>NOTE: Never try to unclog the sprayer nozzle by blowing through it.</i>
<b>6. Test after servicing</b>	<b>After servicing, ALWAYS test the sprayer for leaks with plain water before using.</b>

PROBLEM	CAUSE	SOLUTION
Low pressure	Agitation not tuned properly	Tune agitator with desired agitator tip
	Pressure regulator not adjusted	Adjust pressure regulator
	Worn spray gun nozzle	Replace spray gun nozzle
	Leak in the system	Tighten leaking fitting/hose
Low flow	Agitation valve is open	Close agitation valve
	Agitation not tuned properly	Tune agitator with desired agitator tip
	Strainer clogged	Remove strainer and clean
	Clogged suction line	Remove obstruction
Poor spray distribution	Worn spray gun nozzle	Replace spray gun nozzle
Output drops and the pump is noisy	Pump failure	See pump owner’s manual

# Specifications

## Sprayer Specifications

Item #	5042373
Pump	Comet MC25
Pump Oil	30-weight, non-detergent
Tank Maximum Capacity	55 Gallons
Maximum GPM	5.0 GPM
Maximum Pressure	350 PSI
Spray gun hose length	150 ft.
Maximum hose reel capacity	250 ft. of 3/8" hose
Overall Dimensions	46.5" L x 40" W x 32" H
Dry Weight	280 lbs.
Weight full of liquid	Approx. 720 lbs.
Volts	57.6 Nominal (60V Max)
Amp rating	30 Ah
Charge time	3.5 hours

### Component Materials\*

Tank.....	Polyethylene
Fittings.....	Polypropylene, Nylon, Brass, Stainless steel
Suction line ball valve....	Polypropylene, EPDM, Teflon
Suction line strainer.....	Polypropylene, EPDM, Stainless steel
Hose.....	PVC
Pump.....	Aluminum, Desmopan, Stainless Steel
Hose reel.....	Steel, Brass, Teflon
Gun and Nozzle.....	Brass, Stainless Steel, Teflon

\*Before using any chemical, check to ensure the chemical is compatible with all materials in the system.

The manufacturer reserves the right to make improvements in design and/or changes in specifications at any time without incurring any obligation to install them on units previously sold.

**Any Questions, Comments, Problems or Parts Orders**  
***Call NorthStar Product Support 1-800-270-0810***

# Exploded View – 5042373 – Rev B

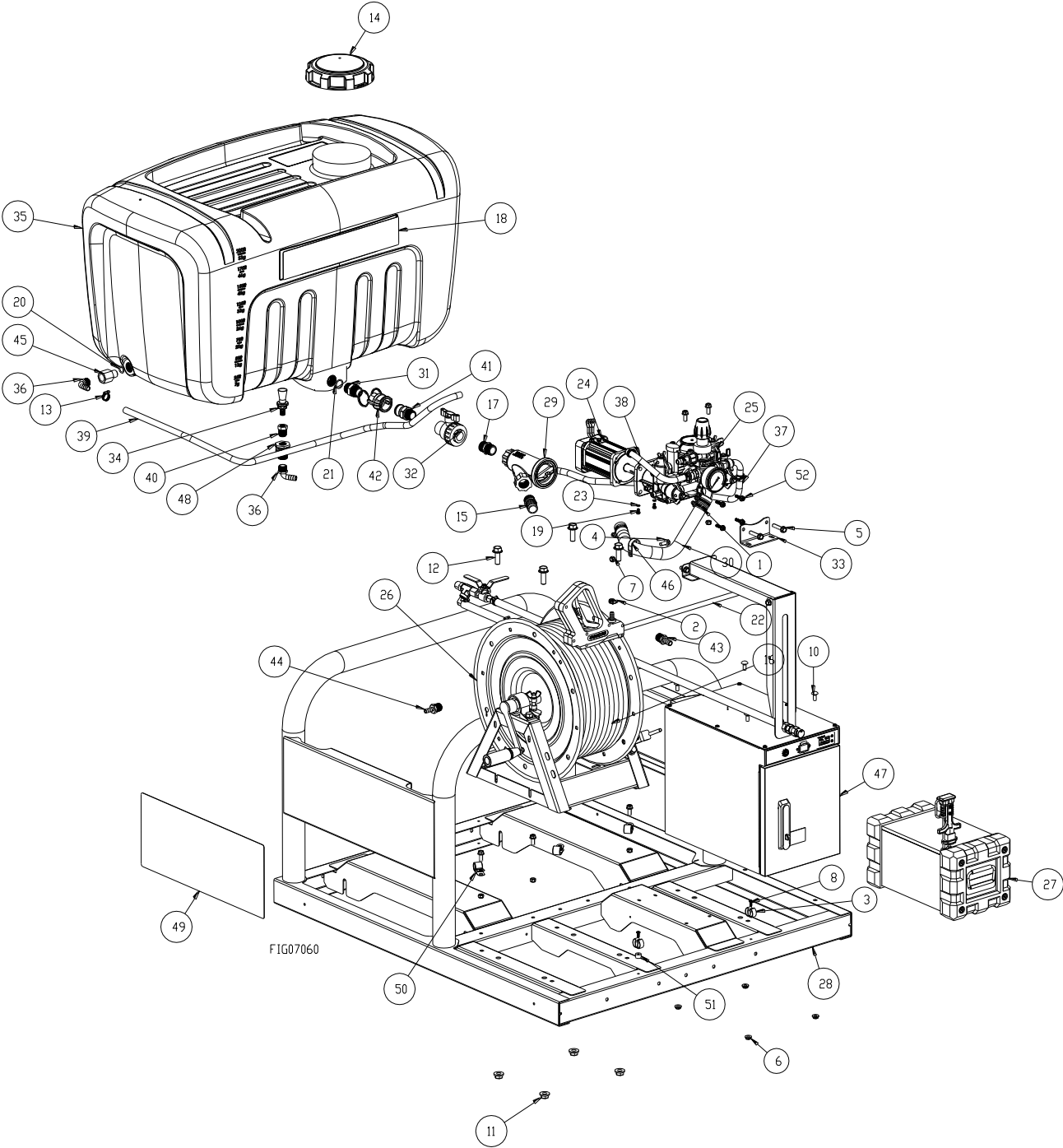
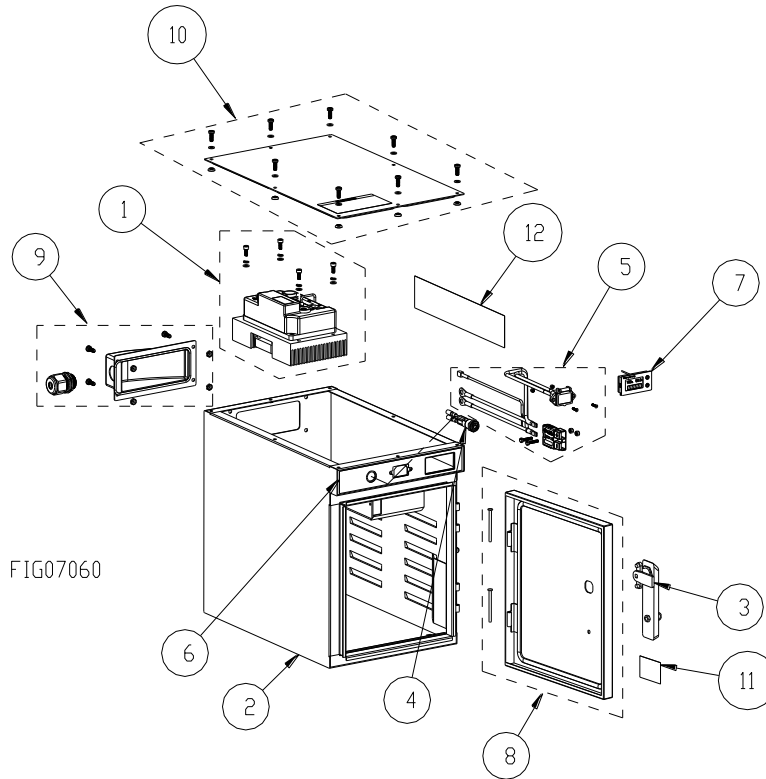

FIG07060

## Exploded View – 5042373 – Rev B

Ref #	Part #	Description	QTY
1	17141	3/4" HOSE CLAMP	3
2	30746	3/8" - 1/2" HOSE CLAMP	1
3	52034	HOSE CLIP	2
4	82015	5/16-18 X 3/4 HHSF BOLT	6
5	82017	SERRATED FLANGE BOLT	2
6	82019	SERRATED FLANGE NUT	4
7	82020	NUT, 5/16-18 NYLON INSERT	8
8	82059	10-24 X 1/2" PAN HEAD PHILLIPS	2
9	-	-	-
10	82088	CARRIAGE BOLT, 5/16 X 3/4"	4
11	82273	M12-1.75 SER FLANGE NUT	4
12	82551	M12-1.75 x 35 HHSF GR5 z	4
13	777119	1/2" - 3/4" HOSE CLAMP	6
14	778143	SPRAYER CAP ASSEMBLY	1
15	779214	3/4" MPT X 1" HB POLY	1
16	779256	3/8" ID HOSE 150'	1
17	779270	3/4" HEX NIPPLE	1
18	779319	BILLBOARD DECAL	1
19	804868	M5-0.8 X 12MM SCREW	2
20	784460	QUICK CONNECT O-RING	1
21	790588	VALVE PLATE O-RING	1
22	798573	DELUXE SPRAY GUN, #2.8	1
23	802459	WASHER, M5 SPRING	2
24	804299	MOTOR, 60V DC, 1.2Kw	1
25	CO6084010000	PUMP, MC25 (SEE PUMP EXP VIEW FOR REGULATOR AND CONTROL VALVE)	1
26	804408	HOSE REEL, GP A-FRAME	1
27	5043106	BATTERY, 60V/30Ah	1
28	804502	SKID SPRAYER FRAME WELDMENT	1
29	804544	STRAINER, 3/4" Y-LINE	1
	805009	STRAINER MESH	1
30	804545	HOSE, 1" X 18" SUCTION	1
31	804546	FITTING, 3/4G X 3/4MPT	1
32	804547	BALL VALVE, 3/4" FPT	1
33	804548	BRACKET, PUMP MOUNT	1
34	804550	EDUCTOR NOZZLE	1
35	804571	200 LITER TANK ASSEMBLY	1
36	804573	FITTING, G1/2 X 1/2" HB ELBOW	2
37	804575	HOSE, 1/2" X 32" HIGH PRESSURE	1
38	804576	HOSE, 1/2" X 10" HIGH PRESSURE	1
39	804577	HOSE, 1/2" X 50" REIN. CLEAR PVC	1
40	804583	FITTING, G1/2 X 1/4" ADAPTER	1
41	804587	QUICK CONNECT, 3/4" PLUG CAM-AND-GROOVE COUPLING	1
42	804588	QUICK CONNECT, 3/4" SOCKET CAM-AND-GROOVE COUPLING	1
43	804607	FITTING, 1/2" MPT X 1/2" HB, BRASS	1
44	804608	FITTING, 1/2" MPT X 3/8" HB, BRASS	1
45	804609	FITTING, 1/2G-M X 1/2G-F, BRASS	1
46	804611	LOOP CLAMP, 1-1/4"	1
47	804620	BATTERY BOX ASM, SPRAYER	1
48	804777	BULKHEAD FITTING, 1/2"ID	1
49	804883	NORTHSTAR DECAL 8.63"x20"	2
50	804904	STRAIN RELIEF HOSE CLIP, 19mm	3
51	804962	SPACER, GUN CLIP	1
52	805012	BOLT, M6-1.0 X 25MM HHFB	4
N/A	5050015	CHARGER	1

# Exploded View – 804620



Ref #	Part #	Description	QTY
1	805127	CONTROLLER KIT	1
	-	MOTOR CONTROLLER	1
	-	SCREW, M5 -0.8 X 15mm PPHM	3
	-	SCREW, M5 -0.8 X 12mm SHCS	4
	-	WASHER, M5 SPRING	4
	-	WASHER, M5 FLAT	4
2	804621	BATTERY BOX WELDMENT, SPRAYER	1
3	804626	LATCH, BATTERY BOX DOOR	1
4	805028	SWITCH, MAIN POWER	1
5	805126	WIRE HARNESS KIT, SPRAYER	1
	-	WIRE HARNESS	1
	-	SCREW, M3 -0.5 X 12mm	2
	-	NUT, M3 -0.5 NYLOC	2
	-	MAIN CONNECTOR	1
	-	BOLT, M4 -0.7 X 20mm HHCS	2
	-	NUT, M4 -0.7 NYLOC	2
	802671	WIRE SLEEVING, 1200mm	1
6	804772	DECAL, CONTROL PANEL, SPRAYER	1
7	805196	BATTERY MONITOR, 60V	1
8	805120	DOOR KIT	1
	-	DOOR	1
	-	PIN	2
9	805122	WIRE ROUTING BOX KIT, SPRAYER	1
	-	WIRE ROUTING BOX	1
	-	CORD STRAIN RELIEF	1
	-	SCREW, #10-24 X 15mm PPHM	4
	-	NUT, #10-24 NYLOC	4
10	805123	BATTERY BOX LID KIT	1
	-	LID	1
	-	SCREW, #10-24 X 15mm PPHM	8
	-	D-RING	8
	-	WASHER, NYLON	8
11	805003	DECAL, LATCH INSTRUCTIONS	1
12	805004	DECAL, 60V LI-ION	1
N/A	804620	BATTERY BOX FULL ASSEMBLY, SPRAYER	1

# Pump Exploded View

• MC 25 •

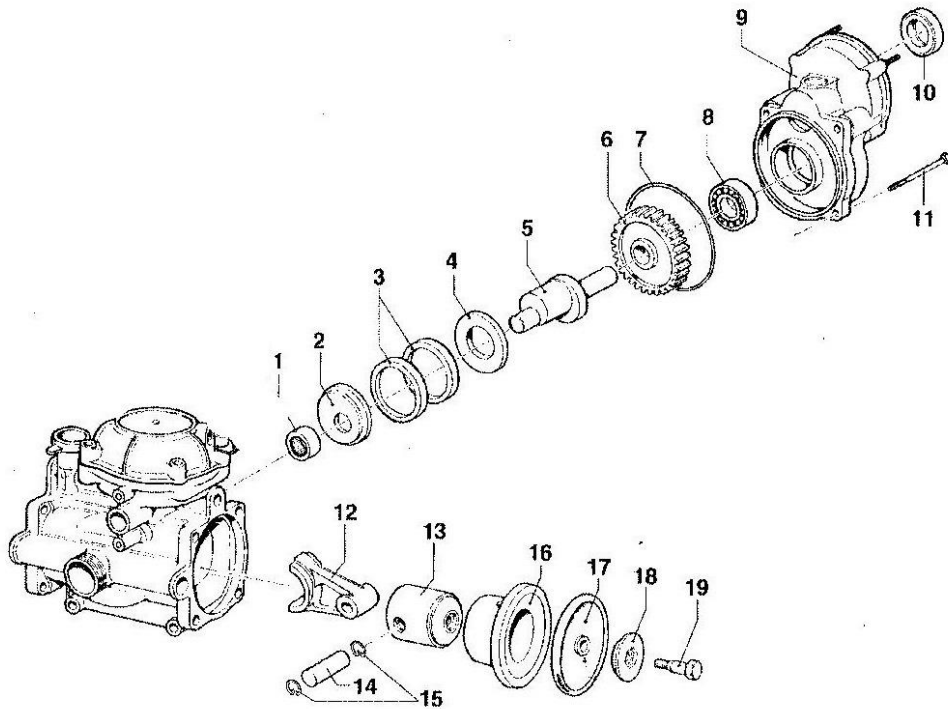

*Regulator shown separately*

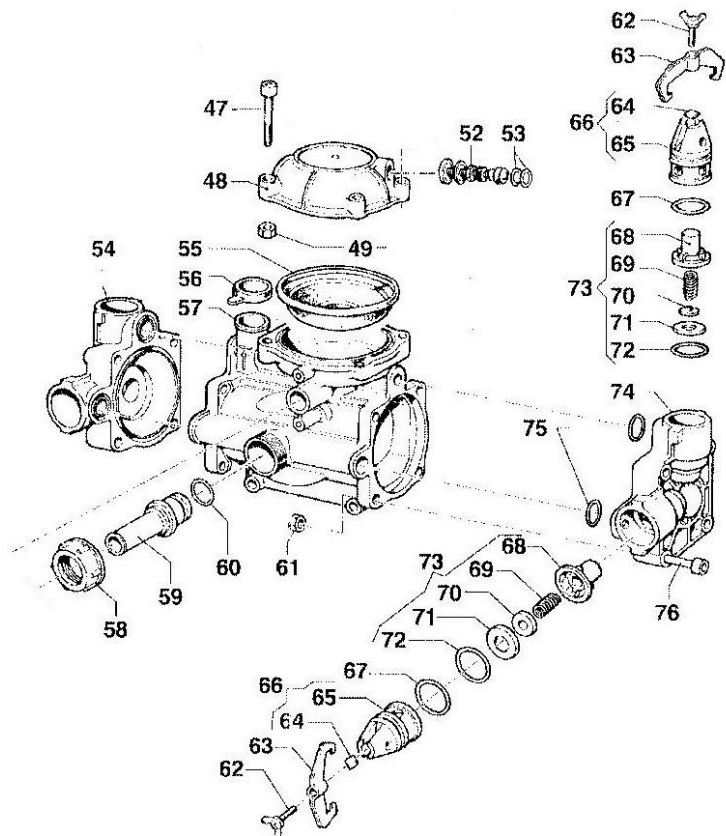

## Pump Exploded View

Ref #	Part #	Description	Qty
1	0437001700	Bearing	1
2	0601023500	Spacer	1
3	0010001200	Conn rod ring	2
4	2813007300	Conn rod washer	1
5	0001029100	Shaft	1
6	0409001900	Gear	1
7	1210005300	O-ring	1
8	0438006500	Bearing	1
9	3002049100	Support	1
10	0019008600	Oil seal	1
11	3609017300	Screw	4
12	0205005900	Conn rod ass'y	1
13	2409002300	Piston	2
14	3011000600	Pin	2
15	3020002000	Retaining clip	4
16	0400006900	Piston sleeve	2
17	1800002000	Diaphragm	2
18	0602003300	Disc	2
19	3605002700	Screw	2

47	3609016500	Screw	2
48	0003001100	Press acc'r	1
49	0604006300	Nut	4
50	3609016200	Screw	2
51	2811001600	Washer	2
52	3610000300	Air valve	1

Ref #	Part #	Description	Qty
53	1209003300	Gasket	2
54	3218001500	Pump manifold	1
55	1800003300	Diaphragm	1
56	1800007900	Oil cap	1
57	0403013400	Pump crankcase	1
58	1200000800	Wing nut	1
59	2801003100	Suction barb	1
60	1210004600	O-ring	1
61	0604006300	Nut	8
62	3605003200	Screw	4
63	0418001800	U clip	4
64	2403007500	Plate	4
65	3202002700	Plug	4
66	3202021400	Tap	1
67	1210005200	O-ring	4
68	1205000700	Valve cage	4
69	1802001500	Spring	4
70	3604000700	Valve	4
71	3009002300	Valve seat	4
72	1210002900	O-ring	4
73	1212000400	Valve kit	4
74	3218001600	Manifold	1
75	1210004600	O-ring	4
76	3609016200	Screw	8

Repair Kit	#5026011600		
Ref #	Part #	Description	Qty
7	1210005300	O-ring	1
17	1800002000	Diaphragm	2
24	0015001300	Rod	1
26	1216000600	Gasket	1
30	1210005700	O-ring	1
31	3600008800	Regulator valve	1
33	1209003000	Gasket	1
42	1210002500	O-ring	1
55	1800003300	Acc'r diaphragm	1
56	1800007900	Oil cap	1
60	1210004600	O-ring	1
67	1210005200	O-ring	4
73	1212000400	Valve	4

# Pump Exploded View

## MC 25 Regulator 1204181800

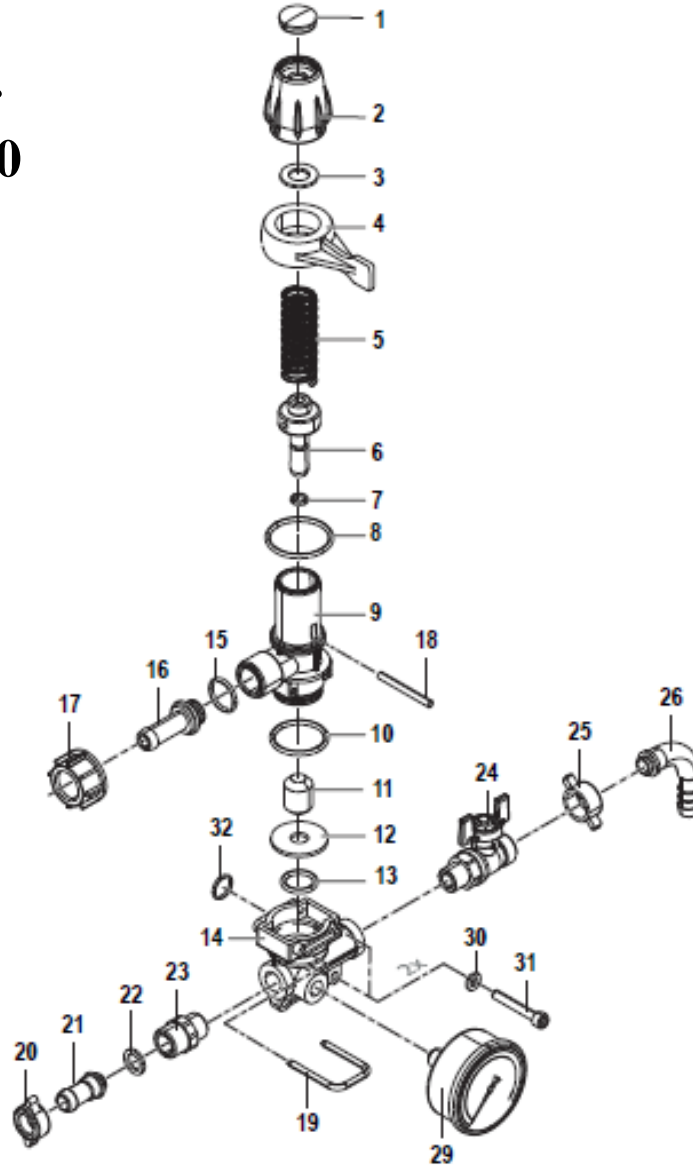

Ref #	Part #	Description	Qty	Ref #	Part #	Description	Qty
1	32020464	Plug	1	16	28000102	Straight Bypass Tail	1
2	12230102	Adjustable Nut	1	17	12000059	Wing Nut	1
3	28120073	Special Washer	1	18	30050027	Pin	1
4	16000078	Lever	1	19	12020051	Hook	1
5	18020043	Spring	1	20	12000038	Right Wing Nut	1
6	24260024	Valve Guide	1	21	28020020	Hose Connector	1
7	12100072	O-Ring	1	22	12090013	Gasket	1
8	12100461	O-Ring	1	23	20000099	Nipple	1
9	04240432	Regulation Valve Body	1	24	28260077	Butterfly Lever Tap	1
10	12100079	O-Ring	1	25	12000066	Wing Nut	1
11	36000009	Pressure Valve	1	26	28030574	Curved Hose Fitting	1
12	30090133	Valve Seat	1	29	18160114	Pressure Gauge	1
13	12100021	O-Ring	1	30	28110030	Washer	2
14	04240371	Control Ass'y Body	1	31	36090100	Screw	2
15	12100036	O-Ring	1	32	12100078	Gasket	1

# Limited Warranty

Dear Valued Customer:

The NorthStar Product you just purchased is built with the finest material and craftsmanship. Use this product properly and enjoy the benefits from its high performance. By purchasing a NorthStar product, you show a desire for quality and durability.

Like all mechanical equipment this unit requires a due amount of care. Treat this unit like the high-quality piece of machinery it is. Neglect and improper handling may impair its performance. Please thoroughly read the instructions and understand the operation before using your product.

## Limited Warranty

NorthStar shall warranty any piece of equipment manufactured, or parts of equipment manufactured, to be free from defects in material or workmanship for a period of 2 years from the date of purchase by user. This warranty applies to the original purchaser of the equipment and is non-transferable. Verification of purchase is the responsibility of the buyer. Parts will be replaced or repaired at no charge, except when the equipment has failed due to lack of proper maintenance. Any misuse, abuse, alteration or improper installation or operations will void warranty. Determining whether a part is to be replaced or repaired is the sole decision of NorthStar.

**NOTE:** Some services performed by parties other than NorthStar may void warranty.

This warranty covers parts only. It will not provide for replacement of complete products due to defective parts. Components not manufactured by NorthStar are guaranteed by their manufacturer and can be serviced at factory-authorized locations near you. Any costs incurred due to replacement or repair of items outside of a NorthStar approved facility is the responsibility of the buyer and not covered under warranty. NorthStar can supply you with the service center location in your area.

This warranty specifically excludes the following: failure of parts due to damage caused by accident, fire, flood, windstorm, acts of God, applications not approved by NorthStar in writing, corrosion caused by chemicals, use of replacement parts which do not conform to manufacturer's specifications, and damage caused by vandalism. Additional exclusions: loss of running time, inconvenience, loss of income, or loss of use, including any implied warranty of merchantability of fitness for a specific use.

Warranty does not cover items subject to normal wear such as tires, receptacles or any part subject to direct physical contact by the public. This warranty does not cover any personal injury or damage to surrounding property caused by failure of any part.

This warranty is in lieu of any other warranty expressed or implied and NorthStar assumes no other responsibility or liability outside that expressed within this warranty.

Please fill in the following information and have it on hand when you call in a warranty claim.

Customer Number: \_\_\_\_\_

Date of Purchase: \_\_\_\_\_

NorthStar Serial Number: \_\_\_\_\_

Item Number: \_\_\_\_\_

**⚠ WARNING:** This product can expose you to soot, tars, and mineral oils (untreated and mildly treated oils and used pump oils), which are known to the state of California to cause cancer.

For more information go to [www.P65Warnings.ca.gov](http://www.P65Warnings.ca.gov).



Manufactured by  
Northern Tool + Equipment Co.,  
2800 Southcross Drive West  
P.O. Box 1499 Burnsville, MN 55337-0499