

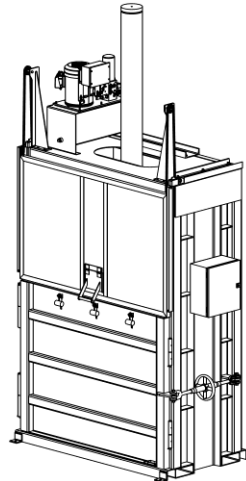

Vestil Manufacturing Co.

2999 North Wayne Street, P.O. Box 507, Angola, IN 46703
 Telephone: (260) 665-7586 -or- Toll Free (800) 348-0868
 Fax: (260) 665-1339
www.vestil.com e-mail: info@vestil.com

CBB-3000-37 CARDBOARD BALER



Receiving Instructions

After delivery, remove the packaging from the product. Inspect the product closely to determine whether it sustained damage during transport. If damage is discovered, record a complete description of it on the bill of lading. If the product is undamaged, discard the packaging.

NOTE: The end-user is solely responsible for confirming that product design, use, and maintenance comply with laws, regulations, codes, and mandatory standards applied where the product is used.

Technical Service & Replacement Parts

For answers to questions not addressed in these instructions and to order replacement parts, labels, and accessories, call our Technical Service and Parts Department at (260) 665-7586. The department can also be contacted online at <https://www.vestil.com/page-parts-request.php>.



Electronic Copies of Instruction Manuals

Additional copies of this instruction manual may be downloaded from <https://www.vestil.com/page-manuals.php>.

TABLE OF CONTENTS	PAGE
Signal Words.....	2
Safety Instructions.....	2
Specifications.....	3
National Standards.....	3
Installing the Baler.....	4
Assembling the Baler.....	5 - 6
CBB-3000-37 Exploded View & Bill of Materials.....	7, 8
Power Unit Exploded View & Bill of Materials.....	9
Power Unit Subassembly Exploded View & Bill of Materials.....	10
Motor/Pump Exploded View & Bill of Materials.....	10
Manifold Subassembly Exploded View & Bill of Materials.....	11
Hydraulic Circuit Diagram.....	11
Manifold, Pressure Switches, and Valves.....	12
208-230V AC Standard Single Phase Electrical Circuit Diagram.....	13
208-230/460V AC Standard 3-Phase Electrical Circuit Diagram.....	14
Using the Baler.....	15 - 16
Record of Satisfactory Condition.....	16 - 17
Inspections & Maintenance.....	17
Labeling Diagram.....	18
Limited Warranty.....	19

SIGNAL WORDS

SIGNAL WORDS appear in this manual to draw the reader's attention to important safety-related messages. The following are signal words used in this manual and their definitions.

 DANGER	Identifies a hazardous situation which, if not avoided, <u>WILL</u> result in DEATH or SERIOUS INJURY. Use of this signal word is limited to the most extreme situations.
 WARNING	Identifies a hazardous situation which, if not avoided, <u>COULD</u> result in DEATH or SERIOUS INJURY.
 CAUTION	Indicates a hazardous situation which, if not avoided, <u>COULD</u> result in MINOR or MODERATE injury.
NOTICE	Identifies practices likely to result in product/property damage, such as operation that might damage the product.

SAFETY INSTRUCTIONS

Vestil strives to identify foreseeable hazards associated with the use of its products, but no manual can address every conceivable risk. Minimize the likelihood of injury by observing the hazards identified below and by inspecting and maintaining the product as instructed in [INSPECTIONS & MAINTENANCE](#) on [p. 17](#).

WARNING

Risks of serious personal injuries or death.

- **Read and understand the entire manual before assembling, using, inspecting, or servicing the baler.**
- Read and understand the entire manual before installing, using, or servicing the product.
- Read the manual whenever necessary to refresh your understanding of proper use and maintenance procedures.
- Do not climb on or into the baler.
- Do not operate the machine if the emergency stop switch does not function properly.
- Do not stand in front of the door during operation.
- Do not disable any of the safety features, e.g. switches, gates/barriers. In particular, the baler must not be able to operate with the loading door open.
- Do not overload the baling chamber.
- Keep clear of all moving parts during operation.
- High pressure oil easily punctures skin and can cause injury such as gangrene. If a hose or coupling develops a leak, repair the leak before operating the baler.
- Do not continue to use the baler if it is damaged or makes unusual noises during operation.
- Do not change the relief valve setting! In particular, do not increase the setting.
- Do not clean out baling chamber unless the baler is disconnected from electrical power.
- Do not attempt to compact filled boxes with this machine. Only fill the baling chamber with empty boxes. Evenly distribute cardboard within the chamber to prevent side loading the baler platen.
- Do not use brake fluids or jack oils in the hydraulic system. Only use AW-32 hydraulic oil or equivalent oil.
- Do not modify the product in any way. Modifications might make the baler unsafe to use and automatically void the [LIMITED WARRANTY](#) on [p. 19](#).
- DO NOT use this device unless every label is in place and easily readable. See [LABELING DIAGRAM](#) on [p. 18](#). Contact the [TECHNICAL SERVICE AND PARTS DEPARTMENT](#) to order replacement labels.

SPECIFICATIONS

The CBB-3000-37 is a single-stage, vertical downstroke baler, i.e. single-stage baler in which the ram only travels up-and-down: A downward compression stroke and an upwards retraction stroke. A specifications document for CBB-3000-37 balers is available online to anyone who visits Vestil's website. Specifications include dimensions, net weight, and capacity information. To access the appropriate specifications document, navigate to this webpage: <https://www.vestil.com/product.php?FID=1704>. Scroll the page to the "Product Specifications Table". Click the button in the "PDFs" column that looks like a pencil inside a box. A PDF file will open. This file is the specifications document. Print a copy of the document and keep it with your copy of this manual. The following is an exemplar specifications document.

CARDBOARD BALER - CBB-3000-37

APPROX WEIGHT: 4178.10 lbs.
DOES NOT INCLUDE WEIGHT OF POWER OR PACKAGING!!!

*** ANY ADDITIONS, DELETIONS, OR OMISSIONS MUST BE CORRECTED ON THIS DRAWING AS THIS DRAWING WILL BE CONSIDERED ALL INCLUSIVE ***
ALL GRAPHICS PROVIDED ARE FOR REFERENCE ONLY. IF CERTAIN DIMENSIONS ARE CRITICAL PLEASE VERIFY THOSE DIMENSIONS WITH YOUR SALESPERSON

Unit ships knocked down (partially disassembled).

DIMENSION TOLERANCE ± 1/2"

STANDARD FEATURES

MODEL NUMBER IS CBB-3000-37
 OVERALL WIDTH: 72 11/16"
 OVERALL DEPTH: 41"
 OVERALL HEIGHT: 140 1/16"
 SHIPPING HEIGHT: 95 11/16"
 LOADING HEIGHT: 23"
 LOAD OPENING HEIGHT: 51 11/16"
 BALE SIZE: 60"L x 30"D x 42"H
 APPROX CYCLE TIME: 60 SEC
 SEMI-AUTO BALE EJECTION SYSTEM
 FRAME IS DURABLE LIQUID PAINT BLUE FINISH
 GATE IS DURABLE LIQUID PAINT YELLOW FINISH

SPECIAL FEATURES

NONE

APPROVAL

I, THE UNDERSIGNED, AGREE THAT THE PRODUCT AS REPRESENTED SATISFIES DESIGN AND DIMENSION REQUIREMENTS. I ALSO ACKNOWLEDGE MY DUTY TO CONFIRM PRODUCT AND INSTALLATION COMPLIANCE WITH ALL APPLICABLE FEDERAL, STATE AND LOCAL REGULATIONS AND STANDARDS.

UNITS REQUIRING APPROVAL DRAWINGS OR MODIFIED ARE NON-RETURNABLE

As drawn As marked

Signed: _____ Date: _____

Printed Name: _____

LEAD TIME WILL START UPON RECEIPT OF SIGNED APPROVAL DRAWING

DISTRIBUTOR'S NAME: VESTIL MANUFACTURING		P.O.# X
DRAWN BY: NBE	DATE: 3/25/2022	W.O.# X
REFERENCE: X	SCALE: 1:32	SALES: X
QUOTED LEAD TIME: X	QUOTE # X	FILE NAME: 22-007-023

NOTE: If your model is not included on the webpage, or if you cannot access and/or print the document, contact the [TECHNICAL SERVICE DEPT.](#) Contact information is provided on the front page of this manual.

NATIONAL STANDARDS

American National Standard ANSI Z245.5 "Baling Equipment – Safety Requirements for Installation, Maintenance and Operation" (the "Standard") provides inspection, testing, maintenance, and operation instructions for single-stage, vertical down-stroke balers. The Standard can be purchased online at <https://webstore.ansi.org/Standards/EIA/ANSIZ2452013-1506110>. Acquire a copy of the Standard. Apply all mandatory provisions. Contact local occupational safety and health specialists to determine whether there are laws, ordinances, codes, etc. ("Authorities") in addition to the Standard that apply to balers in the location where it is used. If content in this manual conflicts with provisions in Authorities or the Standard, apply the provisions from the authorities or Standard. Vestil requests that you immediately contact [TECHNICAL SERVICE](#) to report conflicts.

INSTALLING THE BALER

The following items are necessary to install the device:

- Fork truck.
- Lag bolts, masonry drill, masonry bit, and wrench for lag bolt, grout, and steel shims.
- Power circuit with voltage matching the voltage of the unit including fuses and disconnect or circuit breakers. Minimize voltage drop by using adequate wire size. Refer to NEC 70 for power circuit specifications.

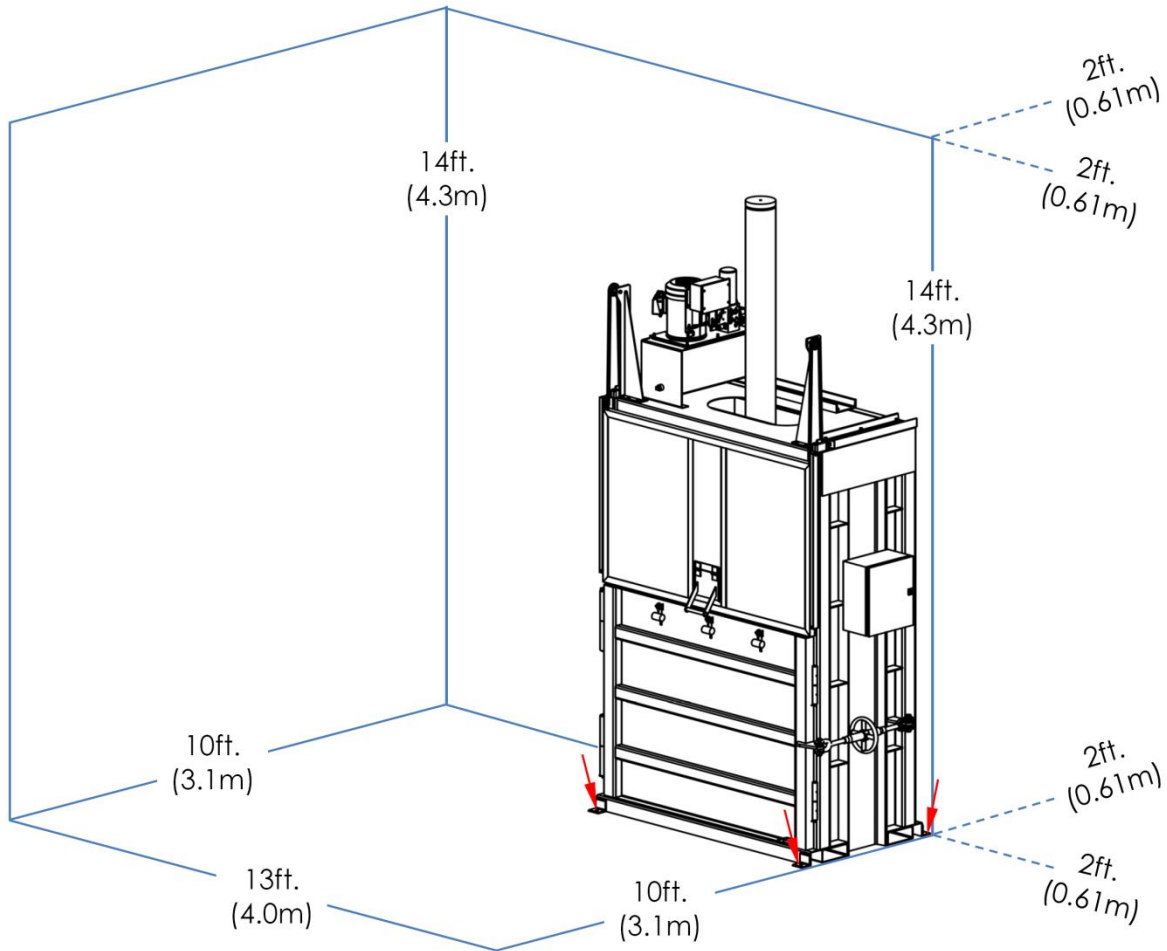

Only install this baler indoors in a location where it will remain dry at all times. Proper installation requires at least 13ft (W) x 10ft (D) of free floor space and 14ft (H) of unobstructed overhead clearance (4m x 3.1m of free floor space and 4.3m of overhead clearance).

Insert the forks of your lift truck into the fork tubes and transport the baler to the installation location. The back side of the baler should be no closer than 24" (61cm) from the closest permanent structure. The baler should only be installed on a steel reinforced concrete surface of at least 3,000psi capacity. Concrete must be at least 4 inches (10.2cm) thick.

Mark the floor with the locations of the anchor bolt holes in the 4 mounting brackets (1 at each corner; arrows in diagrams). Bolt holes will accept 9/16" anchor bolts. 9/16" (14.3mm) anchor bolts should be 6" long (15.2cm). Drill holes at the marked locations according to the instructions provided with your anchoring hardware. Install anchor bolts through the bolt holes and tighten them against the mounting brackets (see arrows in diagram).

ASSEMBLING THE BALER

The following items are necessary to install the device:

- Fork truck or overhead lifting device
- Wrenches or socket wrenches
- Retaining ring pliers.

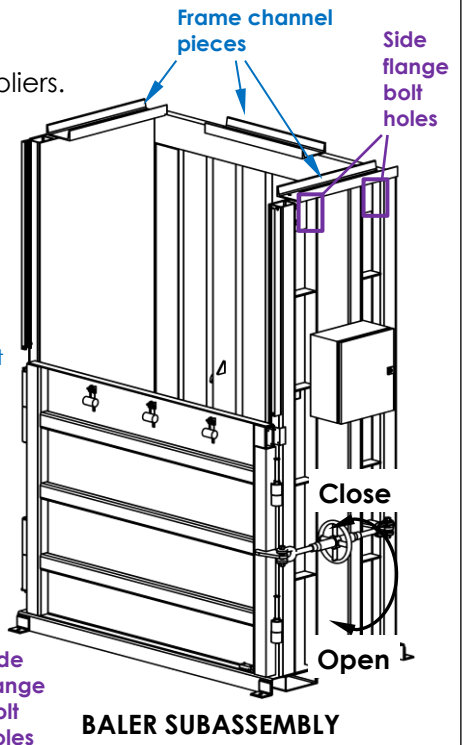
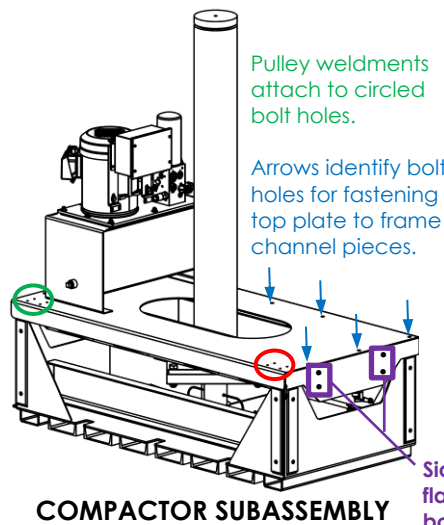
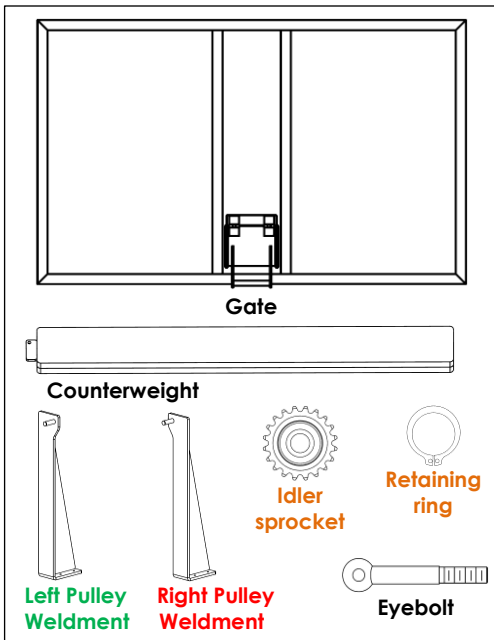

The cardboard baler ships with the compactor subassembly (ram, platen, top plate, power unit) disconnected from the frame channel pieces at the top of the baler subassembly. To assemble the unit:

- 1) Turn the turnbuckle wheel in the OPEN DOOR direction to release the door latch.
- 2) Open the door as widely as possible.
- 3) Lift the upper subassembly with a fork truck, overhead hoist, or other suitable lifting device.
- 4) Align the bolt holes in the TOP PLATE (22-514-062) with the bolt holes in the channel pieces. There are 3 channel pieces and 3 bolt holes in each channel piece.
- 5) Insert 1/2"-13 x 1-1/2" bolts (11209) up through the bolt holes in the top plate and the channel pieces. Put a 1/2" flat washer (33012) on each bolt and secure each connection with a 1/2"-13 lock nut (37030). Tighten all lock nuts.
- 6) Insert bolts (13363) through the side flange bolt holes (4 on each side). Secure each bolt with a washer (33018) and lock nut (37039).

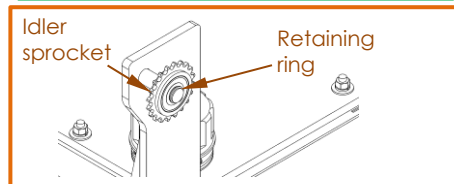
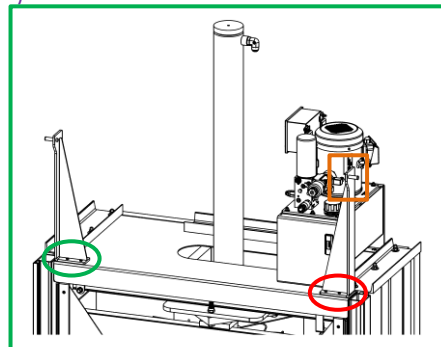
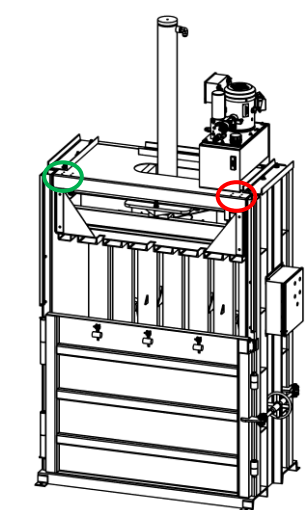
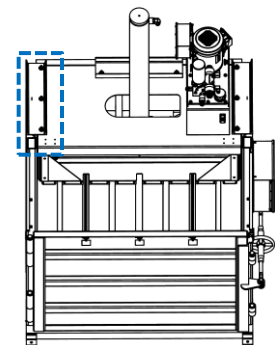
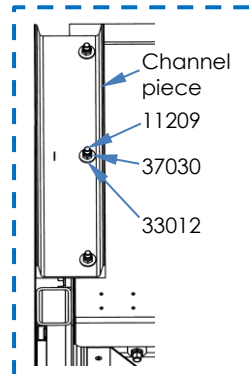

- 7) Attach the left pulley weldment to the top plate (locations circled) with four 1/4"-20 x 1" bolts (11005) and 1/4"-20 lock nuts (37018). Attach the right pulley weldment to the other side of the top plate in the same manner.
- 8) Slide an idler sprocket (20-042-033) onto the sprocket peg of the left pulley weldment. Use a snap ring tool to attach a 5/8" external retaining ring (68013) to the peg. There is a circumferential groove near the end of the peg. Install the retaining ring in this groove. Attach the remaining idler sprocket to the sprocket peg of the right pulley weldment.

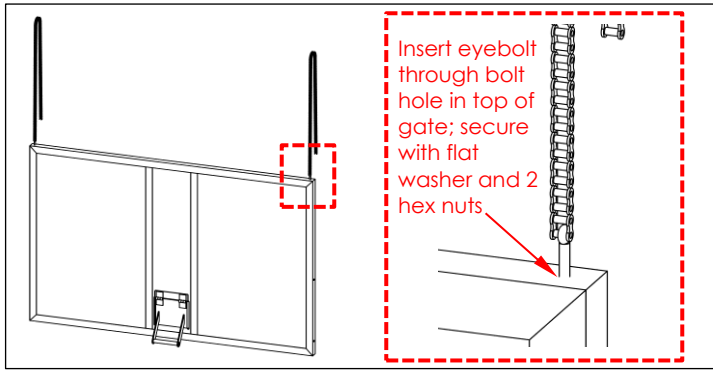

9) Insert an eyebolt (21-145-008) through each bolt hole in the top of the gate. Put a flat washer (33076) and 2 hex nuts (36102) on each eyebolt to secure it in place. Do not tighten the nuts against the gate frame at this point so that the eyebolts can rotate.

10) Lift the gate and chains. Slide the gate into the gate channels with the gate handle on the outside.

NOTE: Steps 8 - 10 are instructions for assembling the gate counterweight system. The baler might ship with chains (22-145-009) already connected to counterweights (22-514-065) and eyebolts (21-145-008).

11) Use a bicycle chain tool to remove the rivet from one end of a counterweight chain (22-145-009). Align the pivot holes in the chain links with the hole in one of the counterweight brackets and reinstall the rivet.

12) Remove the rivet from the other end of the chain. Align the rivet holes in the chain links with the eye of an eyebolt (21-145-008) & reinstall the rivet.

13) Repeat steps 11 & 12 with the other chain, counterweight, and eyebolt.

NOTE: The gate counterweights are heavy. Apply ergonomic lifting practices to avoid back injury.

14) Lift the chains and set them on the idler sprockets. Direct the counterweights into the counterweight receivers. Notice the orientation of the counterweight brackets.

15) Install a 1/4"-20 x 3/4" bolt (11003) through the bolt hole at the top of a gate channel from the outside. Tighten a 1/4"-20 lock nut (37018) on the bolt. Install another bolt and lock nut on the other gate channel.

16) Attach the 2 yellow electrical cords from the power unit to the connectors on top of the control box.

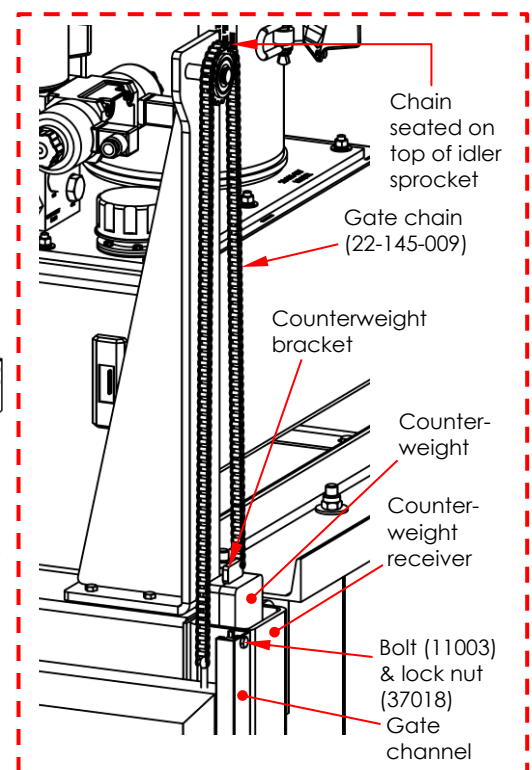
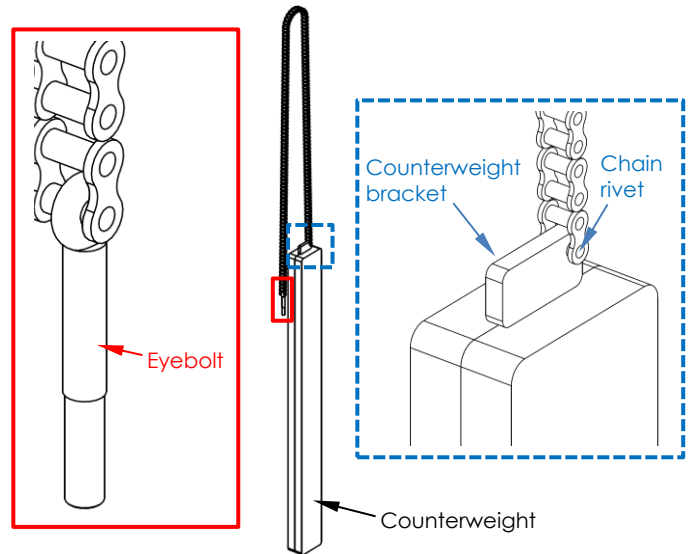
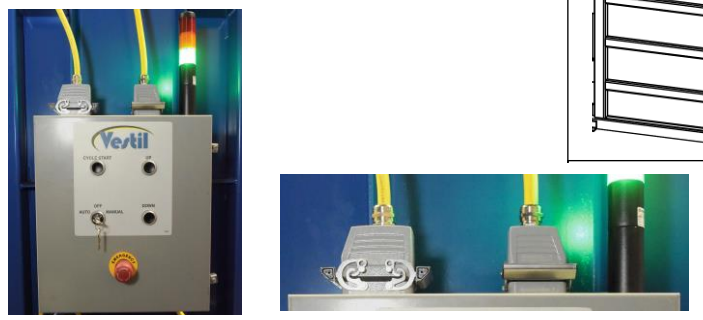

17) Connect the baler to the appropriate power source as shown in the applicable electrical circuit diagram on [page 13](#) (208-230V AC; 1-phase) or [page 14](#) (208-230V/460V AC; 3-phase).

CBB-3000-37 EXPLODED VIEW ([BILL OF MATERIALS ON FOLLOWING PAGE](#))

22-006-023

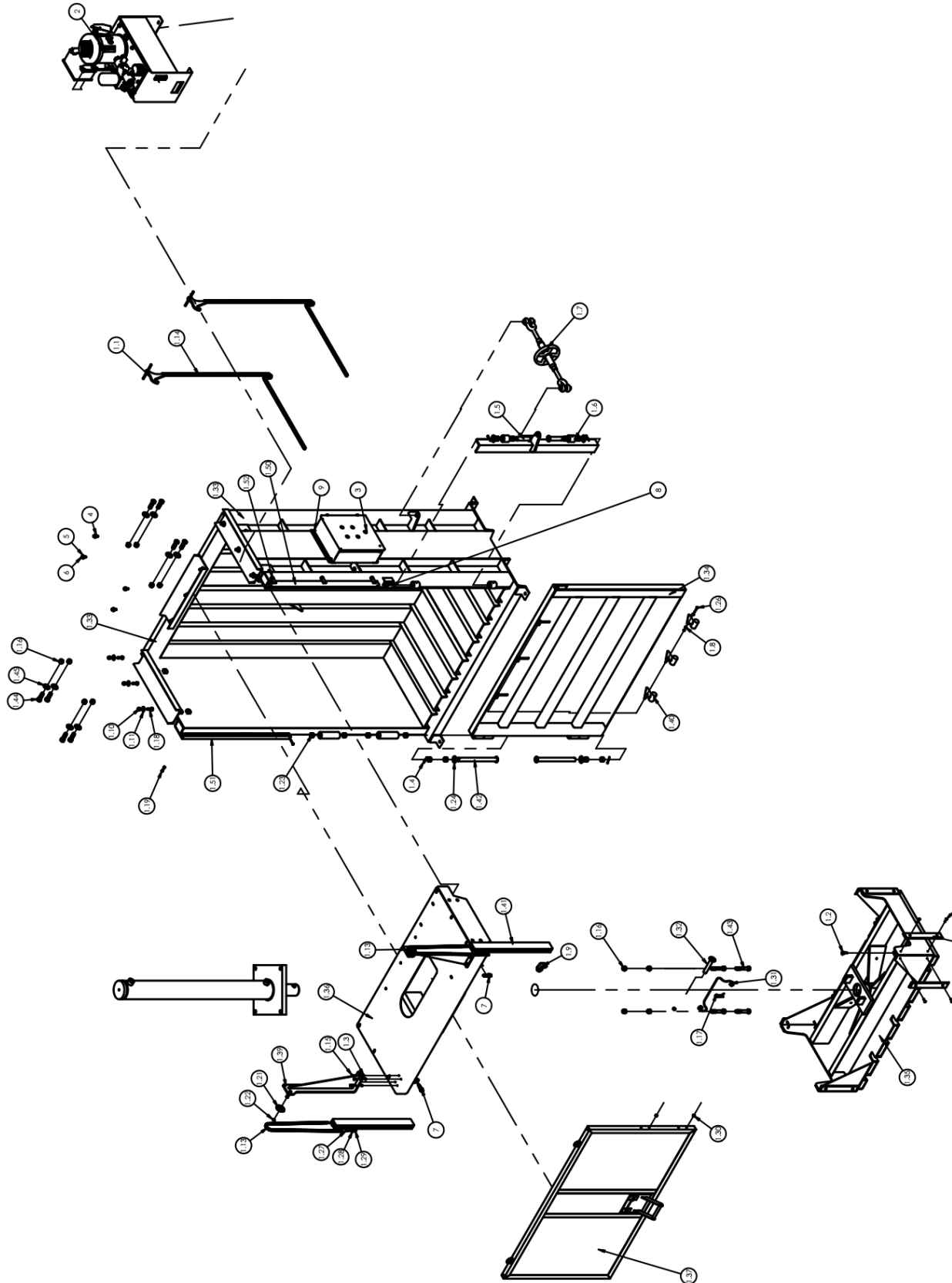

CBB-3000-37 BILL OF MATERIALS (22-006-023)

ITEM	PART NO.	DESCRIPTION	QTY.	ITEM	PART NO.	DESCRIPTION	QTY.
1	22-002-023	FINAL ASSEMBLY W/O POWER UNIT	1	1.3	37021	NYLON INSERT LOCK NUT, GRADE 2, ZINC FINISH, 5/16"-18	4
1.1	22-514-066	WELDMENT, EJECT HOOK	2	1.31	22-514-068	SUBASSEMBLY, SAFETY CABLE	1
1.2	22805	ELEVATOR BOLT, GRADE A, LIMIT SWITCH	1	1.32	22-612-006	WELDMENT, PIN, CYLINDER	1
1.3	37018	NYLON LOCK NUT, GRADE 2, ZINC FINISH, 1/4"-20	15	1.33	22-514-061	WELDMENT, FRAME	1
1.4	65127	COTTER PIN Z PLATED, 3/16 x 2	4	1.34	22-514-063	WELDMENT, MAIN DOOR	1
1.5	22-612-008	WELDMENT, PIN, HINGE	2	1.35	22-513-001	WELDMENT, CRUSH PLATE	1
1.6	22-537-005	WELDMENT, LOCK, DOOR, ANGLE	1	1.36	22-514-062	WELDMENT, FRAME, TOP	1
1.7	22-145-012	SPECIALTY HARDWARE, HANDWHEEL TURNBUCKLE	1	1.37	22-514-064	WELDMENT, FRAME, GATE	1
1.8	22-113-021	SPACER	6	1.38	22-516-007	WELDMENT, PULLEY, RIGHT	1
1.9	99-116-126	FITTING, HYDRAULIC, 16MJ-16MAORB 90° ELBOW	1	1.39	22-516-008	WELDMENT, PULLY, LEFT	1
1.1	37030	1/2"-13 NYLON INSERT LOCK NUT, GRADE 2	9	1.4	22-537-003	WELDMENT, DYNAMIC STOP	3
1.11	33012	FLAT WASHER, LOW CARBON, ZINC FINISH, 1/2"	9	1.41	22-514-065	WELDMENT, COUNTERWEIGHT	2
1.12	24226	1/4"-20 X 1 1/4" FLAT HEAD SOCKET CAP SCREW	16	1.42	22-612-005	WELDMENT, PIN, HINGE	2
1.13	22-145-009	CHAIN, GATE	2	1.43	13371	HEX BOLT, GRADE 5, ZINC FINISH, 3/4"-10 X 4-1/2"	4
1.14	22-145-010	CHAIN, BALE EJECT	2	1.44	13363	3/4-10 x 2 1/2 HHCS #5 Z PLATED, GRADE 5	8
1.15	11005	BOLT, GRADE A, Ø1/4-20 UNC x 1 LG, HHCS #2 Z-PLATED	8	1.45	33018	USS FLAT WASHER, Z PLATED, Ø 3/4"	8
1.16	37039	NYLOCK NUT Z PLATED, GRADE 2, Ø3/4 - 10	12	1.46	22-113-025	SPACER, NYLON, GATE SLIDE	4
1.17	45282	#6 HITCH PIN CLIP	1	1.47	22-021-014	CYLINDER, 5" HYDRAULIC	1
1.18	11209	1/2-13 X 1 1/2" LG HHCS - ASTM A307 GRADE A, ZINC PLATED	9	1.48	22-014-189	FRAME, CHAIN BRACKET	2
1.19	11003	HEX BOLT, GRADE A, ZINC PLATED, 1/4-20 X 3/4"	2	1.49	32408	1/4" x 20 UNC x 3/4", HWH TYPE F THREAD CUTTING	4
1.2	11009	HEX BOLT, GRADE A, ZINC PLATED, 1/4"-20 X 1-1/2"	2	1.5	22-514-078	WELDMENT. GATE RAILING, RIGHT	1
1.21	20-042-033	SPROCKET, IDLER ASSEMBLY	2	1.51	22-514-077	WELDMENT. GATE RAILING, LEFT	1
1.22	68013	Ø5/8 EXTERNAL RETAINING RING	2	1.52	13105	HEX BOLT, GRADE 5, ZINC FINISH, 3/8"-16 X 1"	6
1.23	01-111-073	BUSHING, DU, 1 1/8 ID X 3/4 LG	16	2	22-660-002	SUB-ASSEMBLY, REMOTE POWER UNIT, 208-230/460V AC, 3PH, 6.5 HP, 1750 RPM, .97/.499 DISP., DA, PLC	1
1.24	01-115-001	WASHER, THRUST BEARING, 1 1/8 ID	4	3	99-029-190	ELECTRICAL ENCLOSURE, 16" X 14" X 6", MACHINED	1
1.25	22-113-020	SPACER, NYLON STRIP	8	4	37024	NYLON INSERT LOCK NUT, GRADE 2, ZINC FINISH, 3/8"-16	4
1.26	11010	HEX BOLT, GRADE A, ZINC PLATED, 1/4"-20 x 1 3/4"	3	5	33008	FLAT WASHER, LOW CARBON, USS, ZINC PLATED, 3/8"	4
1.27	21-145-008	SPECIALTY HARDWARE, EYEBOLT	2	6	11107	HEX BOLT, GRADE A, ZINC FINISH, 3/8"-16 x 1-1/4"	4
1.28	33076	#12, SAE FLAT WASHER, ZINC FINISH	2	7	22-022-001	SENSOR, PROXIMITY SWITCH	2
1.29	36102	HEX NUT, GRADE A, ZINC PLATED, 1/4-20	4	8	34-022-001	MAGNETIC POWER UP, ASSEMBLY	1
				9	11005	BOLT, GRADE A, Ø1/4-20 UNC x 1 LG, HHCS #2 Z-PLATED	4

*Shown in detail in [POWER UNIT EXPLODED VIEW](#) on p. 9.

POWER UNIT EXPLODED VIEW & BILL OF MATERIALS

22-660-002 REV. B

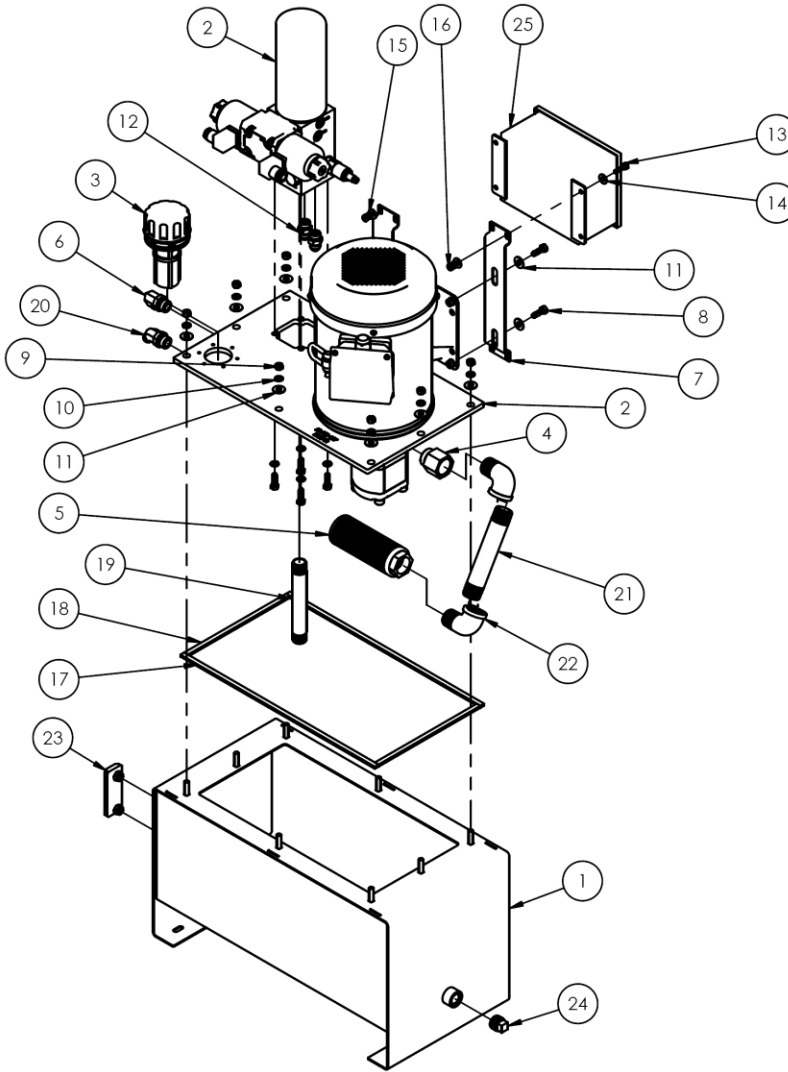

Item	Part no.	Description	Qty.
1	99-523-005	WELDMENT, STEEL RESERVOIR	1
*2	22-160-002	POWER UNIT, SUB ASSEMBLY, 460V AC, 3PH, 6.5 HP, 1750 RPM, .97/.499 DISP., DA	1
3	99-031-036	ACCESSORIES, FILLER BREATHER	1
4	99-116-167	FITTING, HYDRAULIC, 1/6MORB-1/6FP STRAIGHT	1
5	99-031-035	ACCESSORIES, 1" NPT STRAINER	1
6	99-116-123	FITTING, HYDRAULIC, 08MJ-10MAORB 90° ELBOW	1
7	22-016-016	BRACKET, ELECTRICAL BOX	2
8	11055	HEX BOLT, GRADE A, ZINC PLATED, 5/16-18 X 1	4
9	36104	HEX NUT, GRADE A, ZINC PLATED, 5/16-18	12
10	33620	LOCK WASHER, MEDIUM SPLIT, Ø5/16"	12
11	33006	FLAT WASHER, ZINC PLATED, USS, Ø5/16"	12
12	99-116-044	FITTING, HYDRAULIC, 08MJ-08MORB STRAIGHT	2
13	11005	BOLT, GRADE A, Ø1/4-20 UNC x 1 LG, HHCS #2 Z-PLATED	2
14	33004	FLAT WASHER, USS, ZINC PLATED, Ø1/4"	4
15	33618	MEDIUM SPLIT LOCK WASHER, Ø1/4"	2
16	36102	HEX NUT, GRADE A, ZINC PLATED, 1/4-20	2
17	05-031-011	ACCESSORIES, HYDRAULIC, GASKET SEALANT, 20", FORMED	2
18	05-031-009	ACCESSORIES, HYDRAULIC, GASKET SEALANT, 11", FORMED	2
19	99-031-078	ACCESSORIES, PIPE, 3/4" NPT	1
20	99-116-130	FITTING, HYDRAULIC, 08MJ-10MAORB 45° ELBOW	1
21	99-031-055	ACCESSORIES, PIPE, NIPPLE, 1" X 7"	1
22	99-031-039	ACCESSORIES, PIPE, 1" NPT STREET ELBOW	2
23	99-031-038	ACCESSORIES, SIGHT LEVEL GAUGE W/THERMOMETER	1
24	99-031-016	ACCESSORIES, HYDRAULIC, 3/4" PIPE PLUG BLACK NPT	1
25	99-029-130	ELECTRICAL ENCLOSURE, 8" X 6" X 4", ROUGH	1

*Shown in detail in [POWER UNIT SUBASSEMBLY EXPLODED VIEW](#) on p. 10.

POWER UNIT SUBASSEMBLY EXPLODED VIEW & BILL OF MATERIALS

22-160-002 REV. B

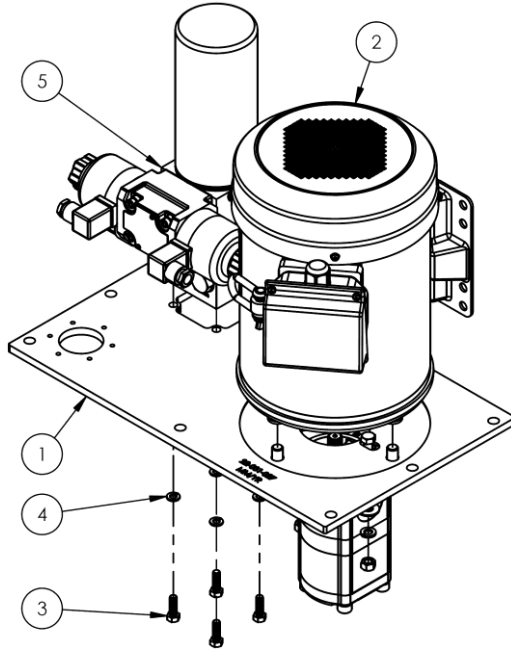

Item	Part no.	Description	Qty.
1	22-031-027	HYDRAULIC PUMP ADAPTER, 20"	1
*2	99-137-043	MOTOR/PUMP, 208-230/460V, 6.5 HP, 3 PH, 1750 RPM, .97/.499 DISP.	1
3	11055	HEX BOLT, GRADE A, ZINC PLATED, 5/16-18 X 1	4
4	33620	LOCK WASHER, MEDIUM SPLIT, Ø5/16"	4
**5	22-627-026	ASSEMBLY, MANIFOLD	1

*Shown in detail in [MOTOR/PUMP SUBASSEMBLY EXPLODED VIEW](#) (below).

**Shown in detail in [MANIFOLD SUBASSEMBLY EXPLODED VIEW](#) on p. 11.

MOTOR/PUMP EXPLODED VIEW AND BILL OF MATERIALS

99-137-043

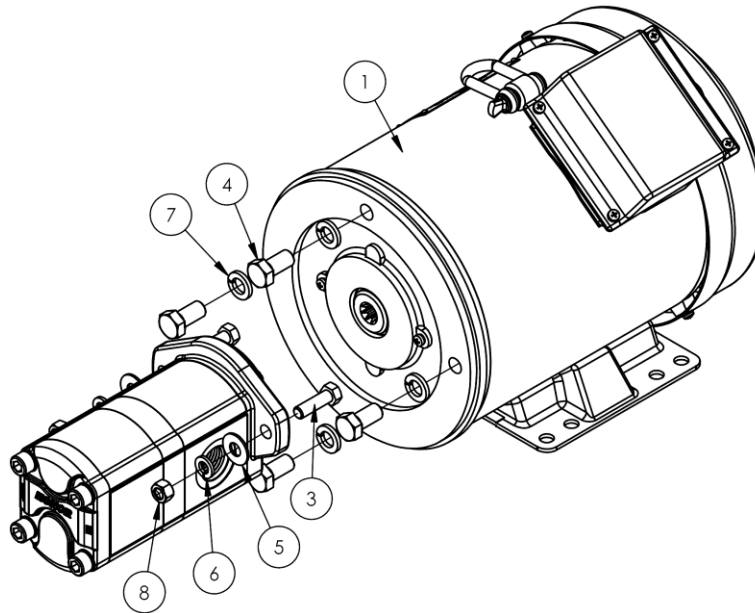

Item	Part no.	Description	Qty.	Item	Part no.	Description	Qty.
1	99-135-036	MOTOR, 6.5 HP, 3 PH, 1750 RPM, 184T, 208-230/460V, 60 HZ, ELECTRIC, 9T SHAFT	1	5	33008	FLAT WASHER, LOW CARBON, USS, ZINC PLATED, 3/8"	2
2	22-143-001	PUMP, HYDRAULIC GEAR	1	6	33622	SPLIT LOCK WASHER, CARBON STEEL, MEDIUM ZINC FINISH, 3/8"	2
3	11107	HEX BOLT, GRADE A, ZINC FINISH, 3/8"-16 x 1-1/4"	2	7	33626	LOCK WASHER Z PLATED, Ø 1/2	4
4	11205	HEX BOLT, GRADE A, ZINC PLATED, 1/2"-13X 1"	4	8	36106	HEX NUT, GRADE A, ZINC PLATED, 3/8-16	2

MANIFOLD ASSEMBLY EXPLODED VIEW AND BILL OF MATERIALS

22-627-026

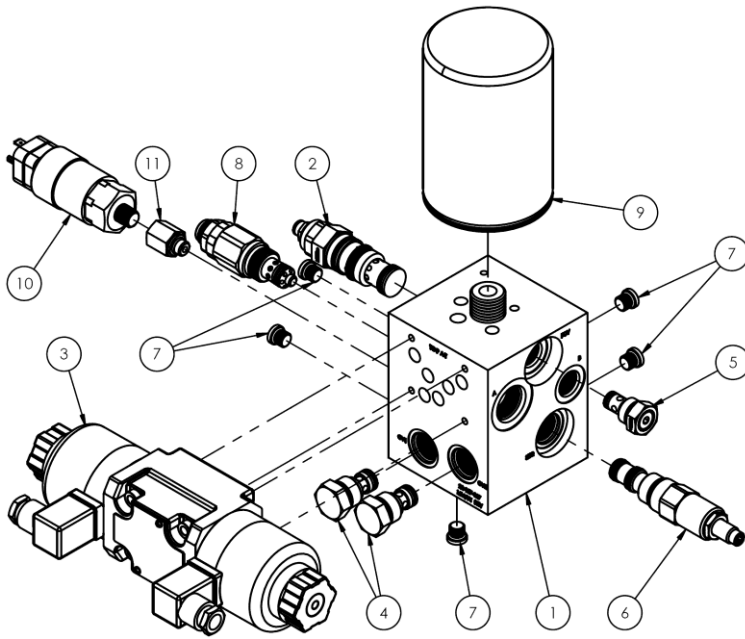

ITEM	PART NO.	DESCRIPTION	QTY.
1	22-127-027	MANIFOLD, HYDRAULIC, DOUBLE ACTING	1
2	99-153-114	VALVE, HYDRAULIC, COUNTERBALANCE, 55T2	1
3	22-153-007	VALVE, HYDRAULIC, 3-POS 4-WAY, SHOCKLESS, TANDEM CENTER, DIN	1
4	99-153-035	VALVE, CHECK, NOSE-IN / SIDE-OUT, SIZE 10, 5 PSI	2
5	99-153-068	VALVE, CHECK, NOSE-IN/SIDE-OUT, 25 PSI	1
6	99-153-028	VALVE, CARTRIDGE, SEQUENCE VALVE, SIZE 10	1
7	99-116-005	FITTING, HYDRAULIC, 04MORB HOLLOW HEX PLUG	5
8	99-153-078	VALVE, CARTRIDGE, RELIEF, NOSE-IN/SIDE-OUT, SIZE 10	1
9	22-031-007	RESERVOIR, FILTER, HYDRAULIC, SPIN-ON, 1"-12 THREAD, 10 MICRON	1
10	99-022-004	SWITCH, PRESSURE, 1200-4500 PSI, SPDT	1
11	99-116-156	FITTING, HYDRAULIC, 04MORB-04FP STRAIGHT	1

HYDRAULIC CIRCUIT DIAGRAM

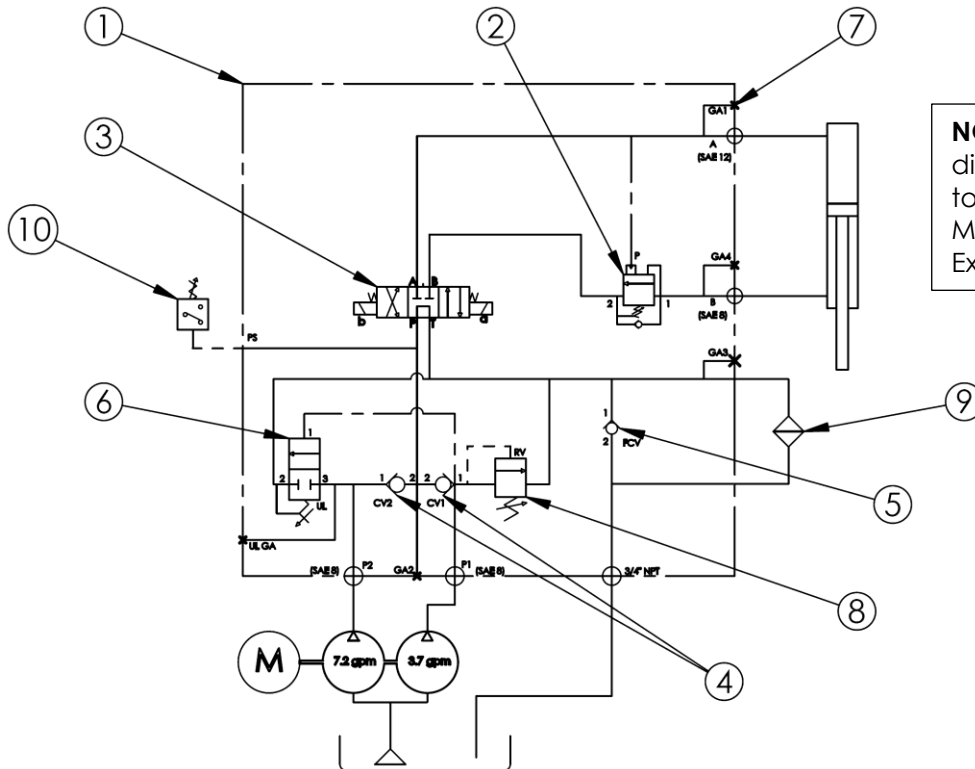

NOTE: Numbers in this diagram correspond to item numbers in the Manifold Assembly Exploded View.

GA1 = PRESSURE REQUIRED TO EXTEND CYLINDER (COMPACT)
 GA2 = SYSTEM OPERATING PRESSURE. NEVER EXCEED 2500 PSI
 GA3 = NO NEED TO TEST
 GA4 = PRESSURE REQUIRED TO RAISE
 UL-GA = PRESSURE AT WHICH THE LARGE PUMP UNLOADS

MANIFOLD, PRESSURE SWITCHES, AND VALVES

Manifold assembly is part no. [22-627-026](#) on [pages 10](#) and [11](#).

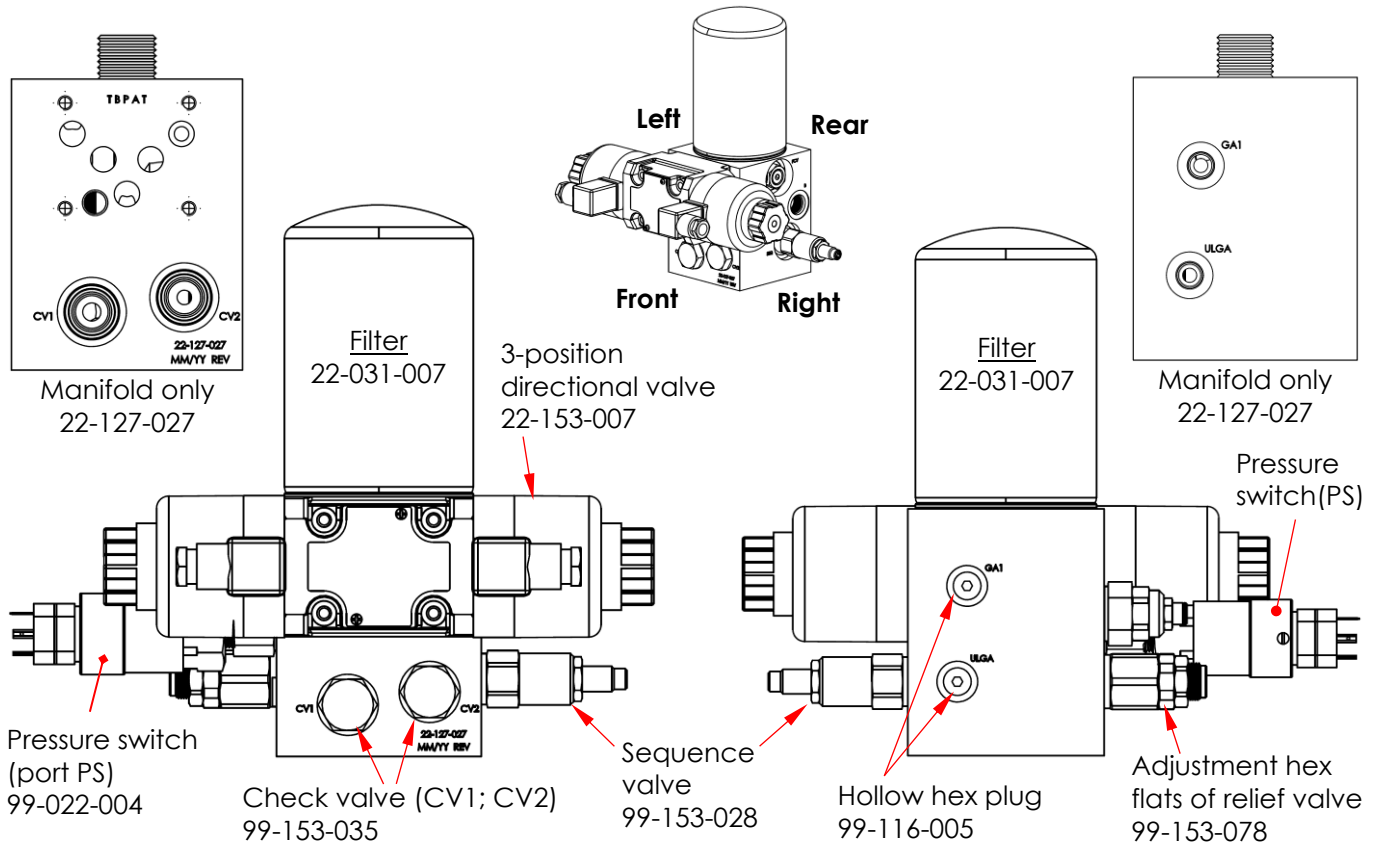

FIG. 5: Front view

FIG. 6: Rear view

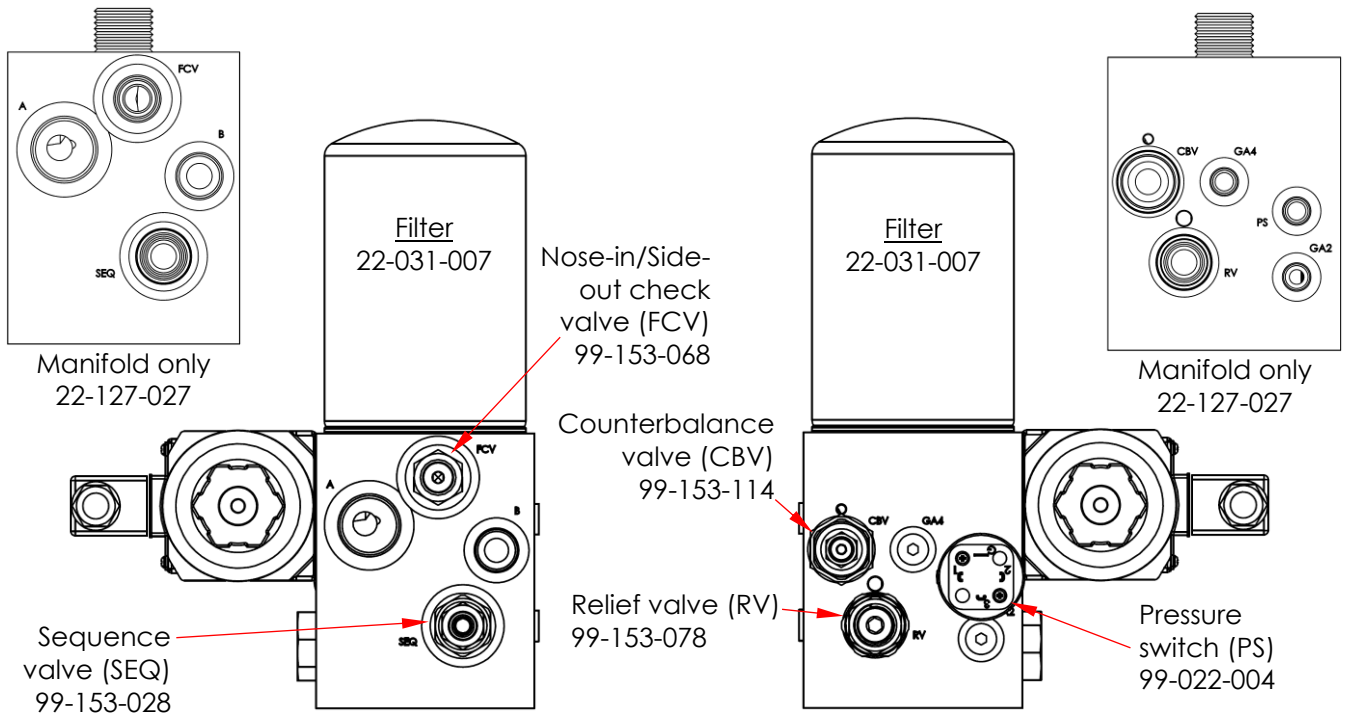

FIG. 7: Left side view

FIG. 8: Right side view

USING THE BALER

Do not attempt to compact anything but cardboard in the baler.

All cardboard containers must be **empty**. Do not attempt to compact filled boxes. Cardboard inside the chamber should be level and evenly distributed within the chamber to prevent uneven loading of the baler platen. Uneven loading could damage the platen, ram, or both.

1. Verify that the baler is connected to electrical power and ready for operation. Check the stack light on top of the control box. The stack light includes three colored lights: red, yellow, and green. The green light should be illuminated. If none of the lights are illuminated, then either baler is not connected to electrical power or the E-stop button is pressed. Raise the E-stop button if necessary.
2. If cardboard is already present in the baling chamber, proceed to step 4. If the baling chamber is empty:
 - a. Press the red E-STOP button;
 - b. Turn the turnbuckle wheel in the OPEN DOOR direction to release the door latch; and then
 - c. Open the baling chamber door and place a full sheet of cardboard on the floor of the baler.
3. Close the baling chamber door. Latch the door by turning the turnbuckle wheel in the CLOSE DOOR direction. Turning the wheel brings the door latch into solid contact with the free end of the chamber door. The green stack light illuminates when the door is closed.
4. Turn the red E-STOP button clockwise until it pops up.
5. Raise the gate and evenly add cardboard to the baling chamber until the chamber is full. DO NOT put material other than cardboard in the baling chamber. The baler must only be used to compact cardboard.
6. Grasp the gate latch handle & pull the gate all the way down.
7. Turn the mode selection switch to the desired mode of operation: MANUAL or AUTO (automatic). In MANUAL mode, the ram only moves while the operator presses control buttons. In AUTO mode, the ram extends and returns to home position *entirely on its own* after the operator presses and releases the CYCLE START button. **The baler should generally be operated in AUTO mode.**
8. Compact the cardboard in the baling chamber.
 - a. If AUTO mode is selected, press the CYCLE START button. Release the button when the platen begins to move and the yellow stack light turns on. The ram extends and causes the platen to compact the cardboard in the chamber. The ram automatically reverses direction and returns to home position. The green stack light turns on when the platen reaches home position.
 - b. If MANUAL mode is selected, press and hold both the CYCLE START and DOWN buttons. The ram extends and presses the platen against the cardboard in the chamber. The ram automatically stops moving when the cardboard is fully compacted. Press both the CYCLE START and UP buttons to raise the platen. The platen automatically stops moving when it reaches home position.
NOTE: ONLY perform step 7 in MANUAL mode to make less-than-full-sized bales.
9. Repeat steps 4-8 until the bale-full condition occurs.
 - a. In AUTO mode, the platen stops *and does not return to home position* and the red stack light turns on. The red stack light illuminates when the baler is full.
 - b. In MANUAL mode, the platen stops moving on its own and the red stack light turns on.
10. If operating in AUTO mode, turn the mode selector switch to MANUAL.
11. Press and hold the CYCLE START and UP buttons until the platen is in home position. Open the gate. Place a full sheet of cardboard on top of the bale. Close the gate. Press and hold both the CYCLE START and DOWN buttons until the platen stops and the red stack light turns on. Then, press the red E-STOP button on the control box.

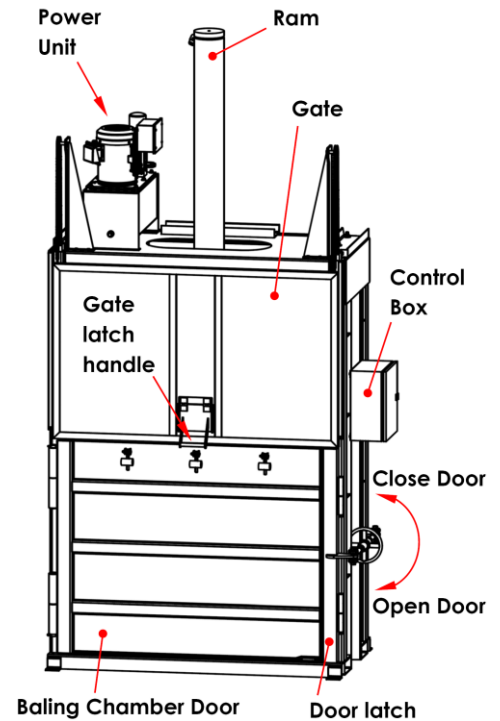
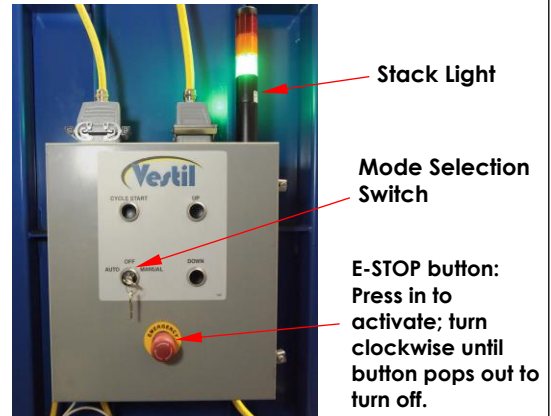

12. Unlatch the door by turning the turnbuckle wheel in the OPEN DOOR direction. Then, open the door as widely as possible.
 13. There are channels in the compacting surface of the platen that extend from the front of the platen to the back of the platen. Feed baling wire/strapping/twine (baling material) through these channels until the baling material comes out of the slots in the back of the baler. NOTE: Do not feed baling material through the channels marked with an X in the diagram. Bale ejecting chains are present at the back of the baling chamber in these locations.
 14. Move to the back of the baler. Pull more of the baling material through the channels. Insert the baling material into the channels in the floor of the baling chamber. Feed baling material through the channels until the ends come out of the front of the bale.
 15. Attach the yellow bale ejecting hooks to the platen.
 16. Move to the front of the baler. Pull the baling material taut and tie it off or crimp it together as appropriate.
 17. Remove all cardboard scraps and other material from the top of the platen.
 18. Make sure that nobody is standing in front of the baler, then twist the red E-STOP button clockwise until it pops out. With the **gate and the chamber door both fully open**, press and hold both the CYCLE START and UP buttons. The platen ascends and the bale is ejected from the chamber.
 19. Clean out the baling chamber and place a full sheet of cardboard on the floor of the chamber.
 20. Disconnect the bale ejecting hooks from the platen. Set the hooks on their holders.
- The baler is now ready to make another bale by repeating steps 3-20.

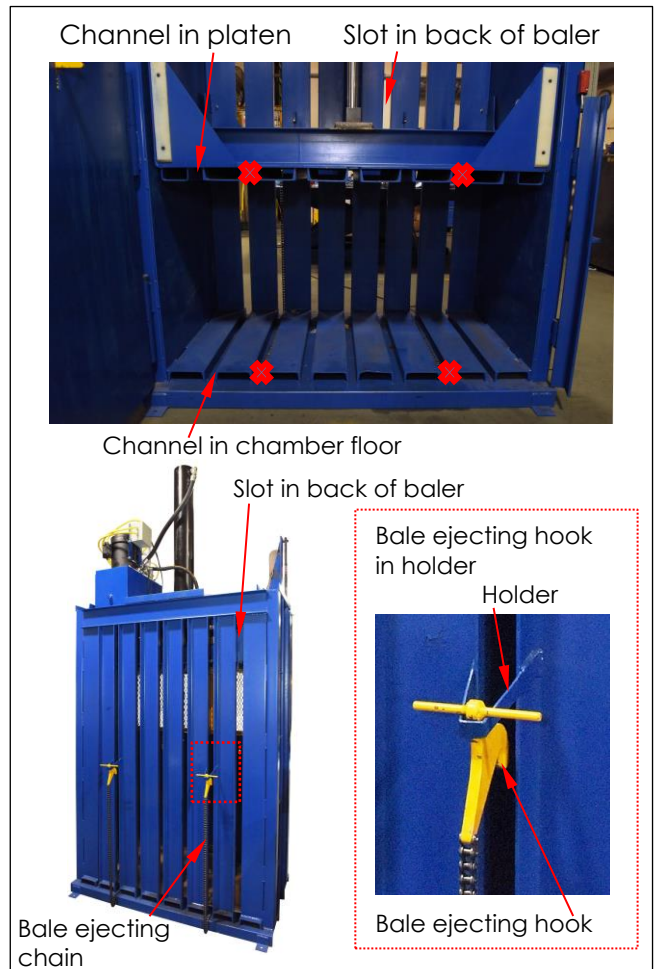

In order to achieve a short cycle time, both sections of the pump in the power unit drive oil to the cylinder until the cylinder pressure reaches approximately 1000 PSI. At this threshold pressure, the high-displacement, low pressure section of the pump begins to direct oil to the reservoir while the low-displacement, high-pressure section continues to direct oil to the cylinder. This arrangement creates a High-Low hydraulic circuit.

As the platen compacts cardboard, oil pressure increases until it reaches the set-point of the pressure switch. The directional valve shifts and oil flows away from the cylinder. Reversing the flow of oil causes the cylinder to retract and raise the platen to the home position. When the cylinder returns the platen to the top of the cabinet, the power unit automatically turns off.

The ram can be stopped at any point during an AUTO cycle. Stop the ram by pressing the red emergency stop button located on the control box. Pressing the button instantly stops the motor and prevents the cylinder from extending any further. Disengage the E-stop button by turning it clockwise. Press the cycle start button again to resume the cycle.

RECORD OF SATISFACTORY CONDITION (THE “RECORD”)

Record the condition of the baler/compactor before putting it into service. Thoroughly photograph the unit from multiple angles. Include close range photographs of the power unit, door hinges and latches/closures, the interior of the baling chamber, the compactor platen, labels, the hydraulic cylinder, frame elements, and anchoring sites. Close the door and operate the baler through a complete cycle (cylinder fully extended and then retracted to home position). Describe the motion of the cylinder, e.g. smooth and at a constant rate, as well as sounds produced by the power unit and cylinder during the cycle. Collect all photographs and writings in a single file. This file is a record of the unit in satisfactory condition. Compare the results of all inspections to this record to determine whether the unit is in satisfactory condition. Do not use the baler unless it is in satisfactory condition. Purely cosmetic changes, like damaged paint/powdercoat, do not constitute changes from satisfactory condition. However,

touchup paint should be applied to all affected areas as soon as damage occurs to prevent rusting and/or corrosion from occurring. Left untreated, rust/corrosion could become a safety concern.

INSPECTIONS & MAINTENANCE

Inspections and repairs should only be performed by qualified persons. Compare the results of each inspection to the [RECORD OF SATISFACTORY CONDITION](#). Do not use the machine unless all parts are in satisfactory condition. Replace parts that are not in satisfactory condition before returning the unit to service. *Never make temporary repairs of damaged or missing parts.* Only use manufacturer-approved replacement parts to restore the unit to satisfactory condition. **DON'T GUESS! If you have any questions about the condition of your baler, contact the [TECHNICAL SERVICE](#) department.** The phone number is provided on the cover page of this manual.

At least once per month (once per week for units used more than 5 times per week), evaluate the condition of the crusher. Repair all issues *before* returning it to service.

1. **Electrical system:** Examine the electrical system for damaged wires/cables.
2. **Hoses:** Inspect hydraulic hoses and fittings for cuts, bulges, tears, kinks, punctures, or other damage causing oil leaks or that could cause leaks.
3. **Ram:** Empty the baling chamber and cycle the ram. Listen for unusual noises and watch for cylinder binding during the cycle. Check the cylinder to make sure that it is not bent, cracked, etc.
4. **Oil:** Check the oil level in the reservoir. With the ram in the home position (cylinder fully retracted), oil should be 2" – 2½" below the top of the tank. If oil is needed, add ISO AW-32 hydraulic fluid or its equal. *Change the oil at least once per year. Immediately change oil if it darkens, looks milky, or becomes gritty. Replace the oil by removing the oil fill plug. Drain oil from the reservoir. Then, flush the reservoir with fresh hydraulic fluid before filling it. Install the drain plug and fill the reservoir with new hydraulic fluid. Only use ISO AW-32 hydraulic oil or its equal.*
5. **Labels:** Make sure that all labels are in place and easily readable from a reasonable distance. See [LABELING DIAGRAM](#) on p. 18.
6. **Compacting system:** Disconnect the baler from electrical power. Open the door. Inspect the platens, cylinder, and crushing chamber. Make sure that the circular compactor platen is securely pinned to the end of the cylinder. Determine the condition of whichever platen(s) will be used. Look for broken welds, cracks, and other damage. Clean the chamber surfaces as needed.
7. **Fork tubes:** Inspect the fork tubes. Tubes should be square and rigid and free of significant rust and corrosion.
8. **Finish:** Repair areas where the finish has been damaged. Use steel wool or a steel bristle brush to remove rust before applying touchup paint to the affected areas.

LABELING DIAGRAM

Label content and location are subject to change without notice. Compare the diagram (below) with your [RECORD](#). If you have any questions about labeling, contact [TECHNICAL SERVICE](#). Replace all labels that are damaged, missing, or not easily readable (e.g. faded). To order replacement labels, contact the [TECHNICAL SERVICE AND PARTS DEPARTMENT](#) online at <https://www.vestil.com/page-parts-request.php>. Alternatively, request replacement parts and/or service by calling (260) 665-7586 and asking the operator to connect you to [TECHNICAL SERVICE](#).

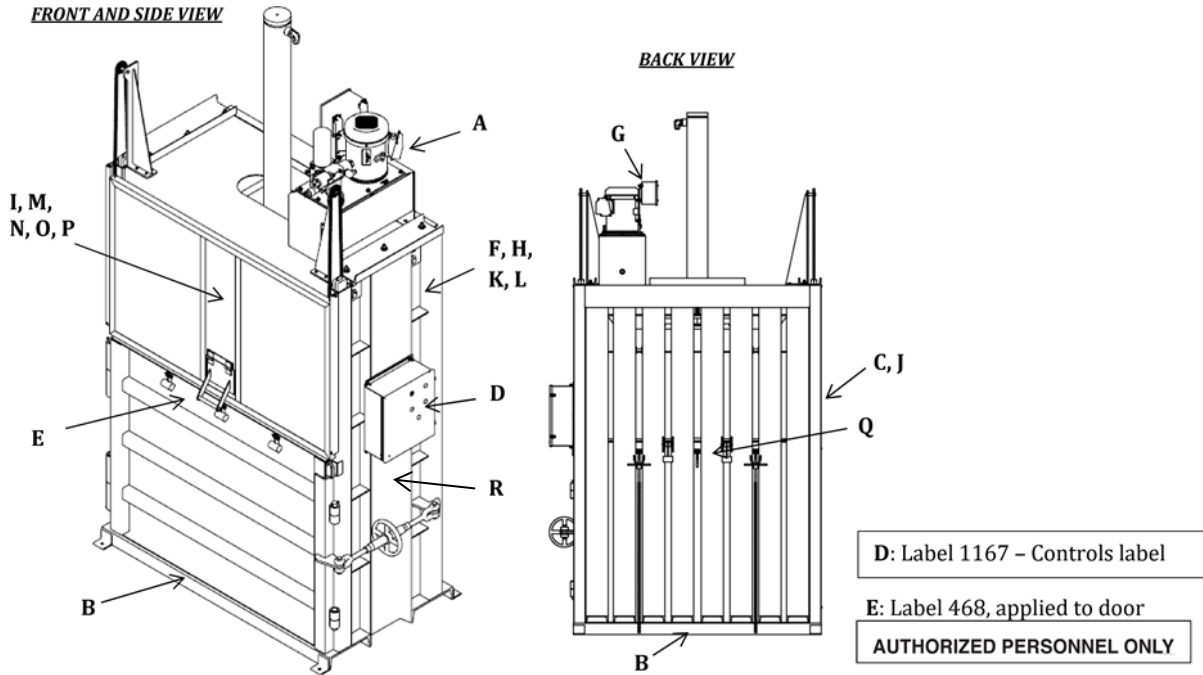

A: Label 206 (oil specifications, applied above reservoir drain plug)

ISO 32 / 150 SUS
 HYDRAULIC OIL OR NON-SYNTHETIC TRANSMISSION FLUID
 ACEITE HIDRAULICO O LIQUIDOS DE TRANSMISION NO SINTETICOS
 HUILE OU LIQUIDE HYDRAULIQUE NON-SYNTHEIQUE

B: Label 1107, applied to base frame front & back

Anchor to Floor

C: Label 970, applied to side opposite of control box

PICK UP FROM THIS SIDE ONLY

F: Label 1185 by control box

WARNING
 Appropriate PPE for Arc Flash and Shock Hazard Required. Refer to NFPA 70E for PPE requirements. Do not operate controls or open covers unless you are wearing appropriate personal protective equipment. Failure to comply might result in death or serious personal injury.

G: Label 221, applied to junction box of power unit

H: Label 249 or 251, applied near control box

I: Label 1173, applied to gate

DANGER
BALE EJECTION AREA
 Do not stand in front of baler while ejecting bale. Failure to comply will result in serious injury or death.

⚠ DANGER ELECTRICAL SHOCK
 Shut power off and consult owners manual before working on this equipment.

⚠ PELIGRO **BI GOLPE ELECTRICO**
 Consulte la corriente consulte el manual de propietario antes de trabajar en este equipo.

⚠ DANGER **CHOC ELECTRIQUE**
 Couper le courant et consulter le manuel d'utilisation avant de travailler sur cet équipement.

NOTICE / NOTA / AVIS
 POWER SUPPLY: 208-230V/1Phase/60Hz
 CONTROL VOLTAGE: 24V AC
 CORRIENTE: 208-230V/1Phase/60Hz
 VOLTAJE DE CONTROL: 24V AC
 ALIMENTATION ELECTRIQUE: 208-230V/1Phase/60Hz
 VOLTAJE DE CONTROLE: 24V AC

K: Label 1186, by control box

WARNING
 US Federal law prohibits tampering with safety devices. Do not override safety devices. Overriding or tampering with safety devices could result in death or serious person injuries.

L: Label 1187 by control box

DANGER
 Lockout switches before working on this baler. Failure to comply will result in death or serious personal injury.

M: Label 1188

WARNING
 Failure to comply with any of the following could result in serious personal injury or death.
 • Do not climb baler.
 • Keep baler clean and free of debris.
 • Bale clean, recyclable cardboard only.
 • Do not put hazardous chemicals or biohazardous materials in baling chamber.
 • Load baling chamber as evenly as possible.

J: Label 1153 with 770 overlay, applied to gate

MODEL / MODELO / MODÈLE _____
 WEIGHT / PESO / MASS _____
 CAPACITY / CAPACIDAD / CAPACITÉ _____
 SERIAL / SERIE / SÉRIE _____
 UNITS: 2.2 lb. = 1kg 1" (or 1in.) = 2.54cm 1153

O: Label 1190

DANGER
 CLOSE GATE BEFORE OPERATING BALER.

P: Label 1191

NOTICE
 Do not operate this baler unless you are at least 18 years old. No exceptions. Baling chamber door must be open more than 90° when ejecting a bale.

N: Label 1189

DANGER
CONFINED SPACE HAZARD
 Apply lockout-tagout procedures before entering baling chamber. Failure to comply will result in death or serious personal injury.

Q: Label 1192

DANGER
TIPPING HAZARD
 Do not store items behind baler.

R: Label 1194 - Operation instructions

Label 1072 is to be applied to the outside of individual packaging

WARNING: Reproductive Health: www.Pfizer.com
ADVERTENCIA: Salud Reproductiva: www.Pfizer.com
WARNING: Cancer: www.Pfizer.com
ADVERTENCIA: Cáncer: www.Pfizer.com

CARDBOARD BALER

01/17/2023



LIMITED WARRANTY

Vestil Manufacturing Company ("Vestil") warrants CBB-3000-37 drum crushers to be free of defects in material and workmanship during the warranty period. Our warranty obligation is to provide a replacement for a defective, original part covered by the warranty after we receive a proper request from the Warrantee (you) for warranty service.

Who may request service?

Only a warrantee may request service. You are a warrantee if you purchased the product from Vestil or from an authorized distributor AND Vestil has been fully paid.

Definition of "original part"?

An original part is a part used to make the product as shipped to the Warrantee.

What is a "proper request"?

A request for warranty service is proper if Vestil receives: 1) a photocopy of the Customer Invoice that displays the shipping date; AND 2) a written request for warranty service including your name and phone number. Send requests by one of the following methods:

US Mail
Vestil Manufacturing Company
2999 North Wayne Street, PO Box 507
Angola, IN 46703

Fax
(260) 665-1339
Phone
(260) 665-7586

Email
info@vestil.com
Enter "Warranty service request" in subject field.

In the written request, list the parts believed to be defective and include the address where replacements should be delivered. After Vestil receives your request for warranty service, an authorized representative will contact you to determine whether your claim is covered by the warranty. Before providing warranty service, Vestil will require you to send the entire product, or just the defective part (or parts), to its facility in Angola, IN.

What is covered under the warranty?

The warranty covers defects in the following original, dynamic parts: motors, hydraulic pumps, motor controllers, and cylinders. It also covers defects in original parts that wear under normal usage conditions ("wearing parts"), such as bearings, hoses, wheels, seals, brushes, and batteries.

How long is the warranty period?

The warranty period for original dynamic components is 1 year. For wearing parts, the warranty period is 90 days. Both warranty periods begin on the date Vestil ships the product to the Warrantee. If the product was purchased from an authorized distributor, the periods begin when the distributor ships the product. Vestil may, at its sole discretion, extend a warranty period for products shipped from authorized distributors by up to 30 days to account for shipping time.

If a defective part is covered by the warranty, what will Vestil do to correct the problem?

Vestil will provide an appropriate replacement for any covered part. An authorized representative of Vestil will contact you to discuss your claim.

What is not covered by the warranty?

The Warrantee (you) are responsible for paying labor costs and freight costs to return the product to Vestil for warranty service.

Events that automatically void this Limited Warranty.

- Misuse;
- Negligent assembly, installation, operation or repair;
- Installation/use in corrosive environments;
- Inadequate or improper maintenance;
- Damage sustained during shipping;
- Collisions or other accidents that damage the product;
- Unauthorized modifications: Do not modify the product IN ANY WAY without first receiving written authorization from Vestil.

Do any other warranties apply to the product?

Vestil Manufacturing Co. makes no other express warranties. All implied warranties are disclaimed to the extent allowed by law. Any implied warranty not disclaimed is limited in scope to the terms of this Limited Warranty. Vestil makes no warranty or representation that this product complies with any state or local design, performance, or safety code or standard. Noncompliance with any such code or standard is not a defect in material or workmanship.