



5' X 8' ALUMINUM TRAILER KIT

Owner's Manual



WARNING:

Read carefully and understand all ASSEMBLY AND OPERATION INSTRUCTIONS before operating. Failure to follow the safety rules and other basic safety precautions may result in serious personal injury.

Item# 49802



5' X 8' ALUMINUM TRAILER KIT Owner's Manual

Thank you very much for choosing an Ultra-Tow Product! For future reference, please complete the owner's record below:

Serial Number/Lot Date Code: _____ Purchase Date: _____

Save the receipt, warranty and these instructions. It is important that you read the entire manual to become familiar with this product before you begin using it.

This 5' x 8' aluminum trailer kit is designed for certain applications only. Northern Tool and Equipment cannot be responsible for issues arising from modification or use of this product in an application for which it was not designed. We strongly recommend that this product not be modified and/or used for any application other than that for which it was designed

For technical questions, please call 1-800-222-5381.

Table of Contents

- Intended Use.....1
- Technical Specifications.....1
- Important Safety Information.....2
- Specific Operation Warnings.....2
- Assembly Instructions.....3
- Trailer Licensing Notice.....10
- Before Each Use.....10
- Operating Instructions.....10
- After Each Use.....12
- Maintenance.....12
- Parts Diagram.....12
- Parts List.....12
- Replacement Parts14
- Limited Warranty.....14

Intended Use

The heavy-duty aluminum trailer kit features a large 5ft. x 8ft. bed, a rustproof aluminum frame, and a 1,715-lb. payload capacity and includes fenders to prevent cargo damage from rocks and debris, and lights make the trailer street legal. Meets all DOT requirements.

Technical Specifications

Property	Specifications
Tires	5.30-12 Tubeless
Bed Dimensions	5-ft. x 8-ft.
Full Dimensions	144"L x 75"W x 22-1/2"H
Ball/Coupler Size	2 Inch
Load Capacity	1715 lbs. max
GVWR	1,980 lbs.
Shipping Weight	186 lbs.

Important Safety Information**WARNING:**

- Read and understand all instructions. Failure to follow all instructions may result in serious injury.
- The warnings, cautions, and instructions in this manual cannot cover all possible conditions or situations that could occur. Exercise common sense and caution when using this tool. Always be aware of the environment and ensure that the tool is used in a safe and responsible manner.
- DO NOT allow persons to operate or assemble this product until they have read this manual and have developed a thorough understanding of how the product works.
- DO NOT modify the product in any way. Unauthorized modification may impair the function and/or safety and could affect the life of the product. There are specific applications for which the product was designed.
- Use the right tool for the job. DO NOT attempt to force a small equipment to do the work of larger industrial equipment. There are certain applications for which this equipment was designed. It will do the job better and more safely at the capacity for which it was intended. DO NOT use this equipment for a purpose for which it was not intended.
- Industrial or commercial applications must follow OSHA requirements.

**WARNING:****WORK AREA SAFETY**

- Inspect the work area before assembly. Keep work area clean, dry, free of clutter, and well lit. Cluttered, wet, or dark work areas can result in injury.
- Do not assemble the trailer where there is a risk of causing a fire or an explosion; e.g., in the presence of flammable liquids, gases, or dust. Assembly can create sparks, which may ignite the dust or fumes.
- Keep children and bystanders away from the work area while assembling the trailer. Do not allow children to play on the trailer.
- Be aware of all power lines, electrical circuits, water pipes, and other mechanical hazards in your assembly area. Some of these hazards may be below the work surface hidden from your view and may cause personal harm or property damage if unintentionally contacted.

PERSONAL SAFETY

- Stay alert; watch what you are doing, and use common sense when assembling and towing the trailer. Do not assemble or tow with the trailer while you are tired or under the influence of drugs, alcohol, or medication. A moment of inattention may result in serious personal injury.
- Do not wear loose clothing, dangling objects, or jewelry during assembly. Loose clothes, jewelry, or long hair can be caught between parts.
- During assembly, use ANSI-approved safety goggles or safety glasses with side shields. Use a dust mask in dusty work conditions. Also use non-skid safety shoes, gloves, and hearing protection when appropriate.
- Do not overreach. Keep proper footing and balance at all times.

Specific Operation Warnings**WARNING:**

- Before each use, always examine the trailer for proper tire condition and air pressure, damaged Tail Lights, damaged Side Running Lights, loose bolts and nuts, structural cracks, bends and any other condition that may affect its safe operation. Do not use the Trailer even if minor damage appears.

- Before each use, always attach the Safety Chains of the trailer to the towing vehicle. Make sure the Safety Chains are attached to the towing vehicle with the equal length at each side. Do not allow the Safety Chains to drag on the ground.
- Always check to make sure the payload being transported properly and safely secured in the trailer. Load the Trailer evenly from side to side with 60% of the load forward of the Axle.
- Make sure the towing vehicle is capable of towing this trailer and its payload. Make sure the hitch on the towing vehicle is capable of towing the Trailer and its payload. The towing capacity of the hitch is typically stamped on the hitch drawbar.
- Make sure the hitch coupler and the vehicle's Ball Hitch (not included) are of equal mating size (2in.) and are rated equal to or greater than the weight of the trailer and its payload.
- Do not exceed 45 miles per hour when towing the trailer. Excess speed is a major cause of vehicle-trailer accidents.
- The Tail Light Bulbs supplied with this trailer are for a 12 Volt DC electrical system only. Do not attempt to power the Light Bulbs with any other type or voltage electrical current.
- Whenever possible, park the trailers on a flat, level, paved surface and chock both tires to keep the trailer from accidentally moving.
- Before attempting to fold up the trailer, make sure it is on a flat, level, solid surface and chock both tires.
- DO NOT exceed the 1715 pound weight capacity.
- DO NOT allow anyone to ride in the towed vehicle or on the trailer.
- The coupler must be properly secured to the hitch ball. After assembly and attachment, pull up and down on the hitch coupler to make sure the hitch ball is snug in the hitch coupler. If the coupler is not secured properly, it could come loose while the trailer is in motion, causing property damage, serious personal injury or even death.
- Make wide turns when towing a loaded trailer, avoiding both sharp turns and U-turns. Turning too sharply can cause damage to the trailer and/or the tow vehicle.

Assembly Instructions**Warning:**

- Beams have sharp edges. Wear work gloves to prevent cuts on hands and fingers.
- Wear ANSI Z87.1 compliant safety goggles.

Read sections 1 – 7 and all the sub-steps of these assembly instructions carefully and follow them step-by-step for easy and correct assembly. Also be sure to read the licensing notice at the end.

NOTE:

- The trailer parts are called out by standing at the rear of the trailer looking forward toward the coupler (left & right).
- Do not fully tighten any nuts and bolts until the entire trailer is assembled. Installing the plywood deck (not included) is the last step after tightening all the nuts and bolts.

1. Open the boxes and check the contents of the three boxes to ensure that all parts are present:

Box 1

1 hardware kit	2 leaf springs	1 safety chain
2 wheels	2 hubs	1 lights set
2 fenders	1 coupler	1 light brackets set
2 fender brackets	1 coupler plate	

Box 2	Box 3
1 tongue set	6 cross members
2 side rails	2 leaf spring hangers
1 axle	1 spare tie bar

SECTION 1: FRAME ASSEMBLY

2. Lay out the side rails (1) and the six cross members (2). NOTE: the 3rd, 5th and 6th cross members are reversed as shown below.
3. Assemble the side rails (1) with the cross members (2) using M10*25 bolts, \varnothing 10 flat washer and M10 nuts (30, 28, 29 bolt set A). NOTE: there are 2 small holes with one regular hole on the wall of side rail must be toward the front.
 - a) Lightly tighten the bolts on the top and bottom first.
 - b) Use a squaring tool to square the frame before fully tightening bolts.
 - c) Fully tighten the corners opposite each other before tightening bolts near the middle.
 - d) Periodically check that the frame stays square during tightening.
4. Bolt the spring hangers (17) with the side rails using M10*25 bolts, \varnothing 10 flat washer and M10 nuts (30, 28, 29 bolt set A).

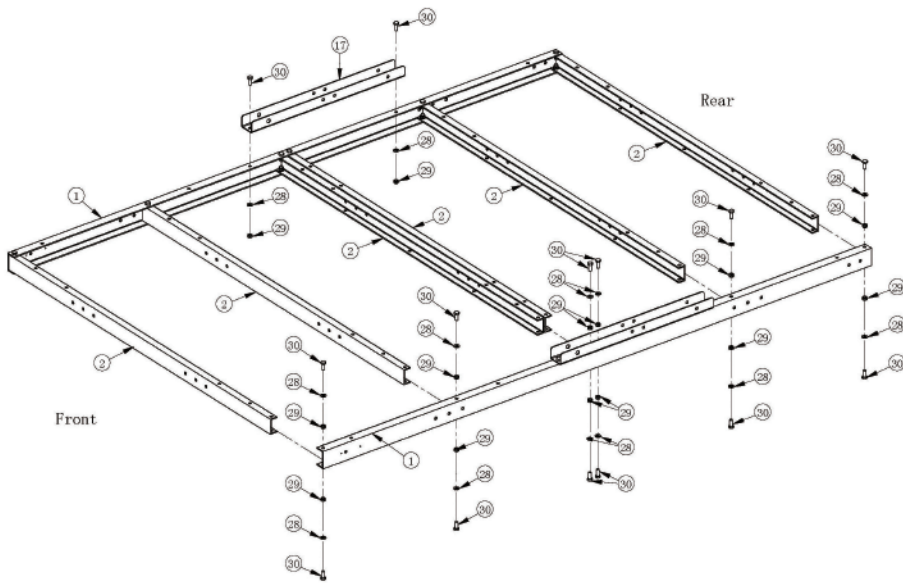

SECTION 2: FENDER ASSEMBLY

5. Bolt the fender seats (21) to the spring hanger using M10*25 bolts, \varnothing 10 flat washer and M10 nuts (30, 28, 29 bolt set A).
6. Bolt the fenders (20) to the fender seats using M10*25 bolts, \varnothing 10 flat washer and M10 nuts (30, 28, 29 bolt set A).

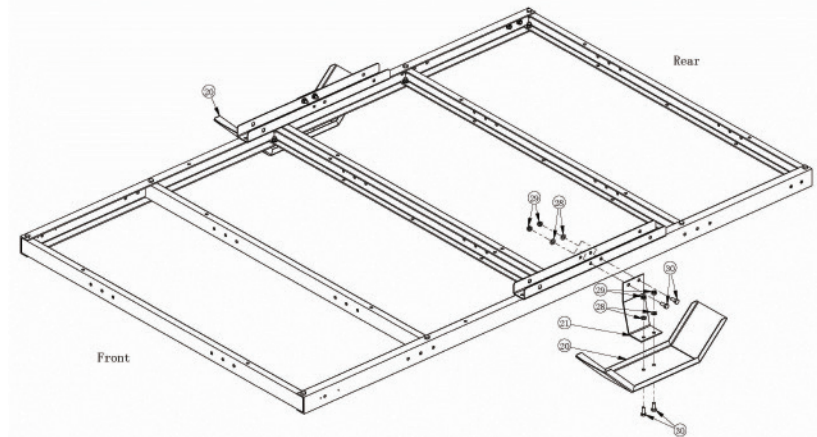

SECTION 3: WHEEL ASSEMBLY

7. Place the leaf springs (11) on the spring hangers with the spring eye toward the front and secure with M14*80 bolt, \varnothing 14 flat washer and M14 nylon lock nut (32, 33, 34 bolt set B) at front portion and M10*80 bolt, \varnothing 10 flat washer and M10 nylon lock nut (31, 28, 29 bolt set B) at rear portion as shown below. (Do not over tighten.)
8. Place the axle (9) on the leaf springs. NOTE: The hole in the axle must face downward. The bolt hole in the center of the leaf springs should match with the bolt holes on the axle (see parts diagram). Put the spring plates (18) under the leaf springs, then using U bolts (19) pass them through the axle, leaf springs and into the holes of the spring plates (18) (18, 19 bolt set B). Secure the assembly with \varnothing 10 flat washers and M10 nylon lock nuts (28, 29 bolt set B) as shown below.

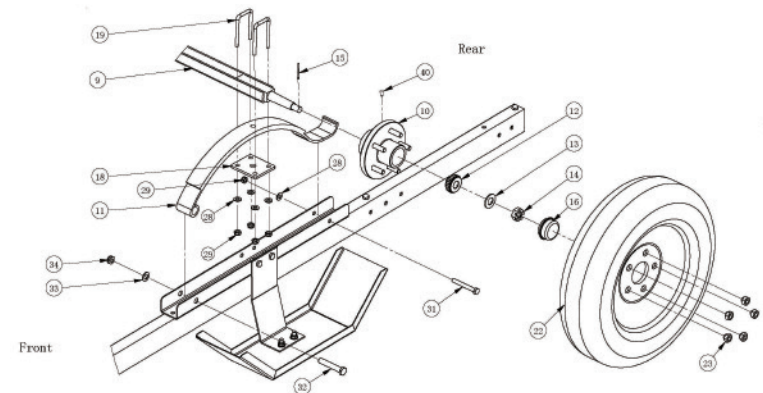

9. Locate both tire/hub assemblies (22, 10). Using a flat head screwdriver and rubber mallet, pry open the dust cap (16) of the wheels and find the cotter pin (15).
10. Attach both tire/hub assemblies to the axle (9) by sliding the hub (wheel studs pointed outward) over the axle spindles. Slide the outer bearings (12) onto the spindles and into the bearing caps in the hubs. Secure the hubs with washers (13) and castle nuts (14). Tighten them snugly then back off the castle nuts (14) a little bit so that the hubs can spin freely.
11. Grease the grease fittings (40) located on the backside of each hub assembly.
12. Insert cotter pins (15) through the holes at the end of axle spindles and bend the pins over to lock it in place. Gently tap the dust caps (16) over the hub openings until the flange of the cap seats is on the hubs.
13. Secure each tire /wheel assembly using the lug nuts (23). Torque the lug nuts to 85-90ft-lbs.

SECTION4: TOW BAR ASSEMBLY

14. Attach the tow bar rails (3) to the side rails (1) and cross member (2). NOTE: the tow bar rails should have the three holes end toward the front. Secure with M10*25 bolts, 10 flat washer and M10 nuts (30, 28, 29 bolt set A).
- Do not fully tighten the bolts yet. Leave them loose enough to adjust the tow bar in step 5.
15. Place the stand base (6) at the front of the tow bar rails (3), secure with six holes by M10*25 bolts, 10 flat washer and M10 nuts (30, 28, 29 Bolt set A) as shown.
- Do not fully tighten the bolts yet. Leave them loose enough to adjust the tow bar in step 5.

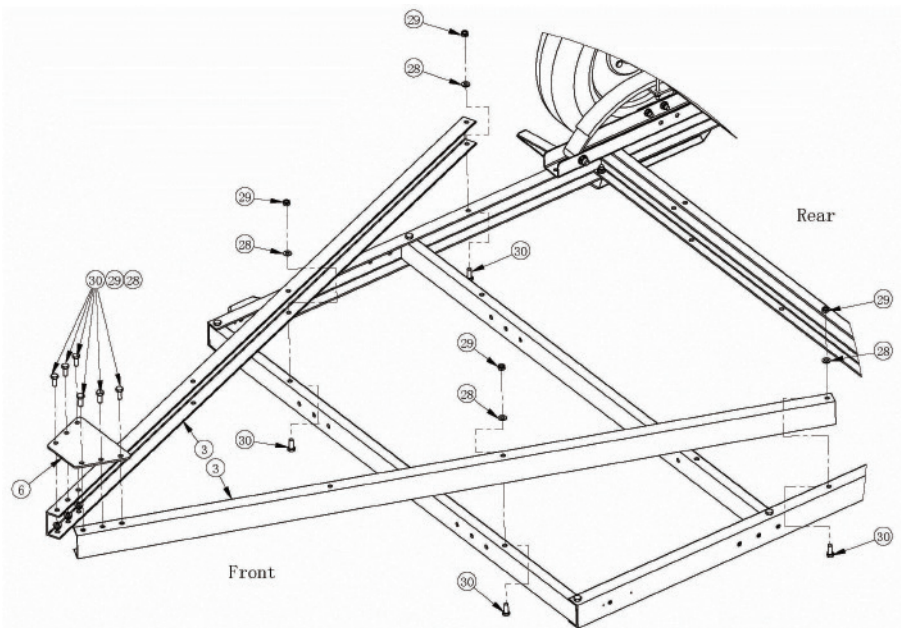

SECTION5: HITCH ASSEMBLY

16. With assistance, turn the trailer assembly over (with the wheels on the ground).
 17. Attach the spare tire bar (4) to the tow bar and secure with M10*25 bolts, 10 flat washer and M10 nuts. (30, 28, 29 Bolt set C).
- Do not fully tighten bolts yet. Leave the bolts loose enough to adjust the tow bar (below).
18. Bolt coupler (7) to the coupler base (5) with M12*90 hex bolts, flat washers, and M12 nuts (35, 36, 37 bolt Set C), attach the safety chain (8) to the coupler with bolt M12*90 by putting the bolt through the center link of the chain, then lock it. NOTE: Make sure the chain is the same length on each side.
 19. Place the coupler with coupler base (7, 5) on the front of the tow bar and secure it with sets of M10*25 bolts, 10 flat washers and M10nuts (30, 28, 29 Bolt set C) as shown.
 20. Adjust the tow bar so it is in line with the center line of the frame to help prevent the trailer from fish-tailing during towing.
 21. While keeping the tow bar aligned with the frame, fully tighten all bolts on the tow bar, spare tire bar, and coupler.

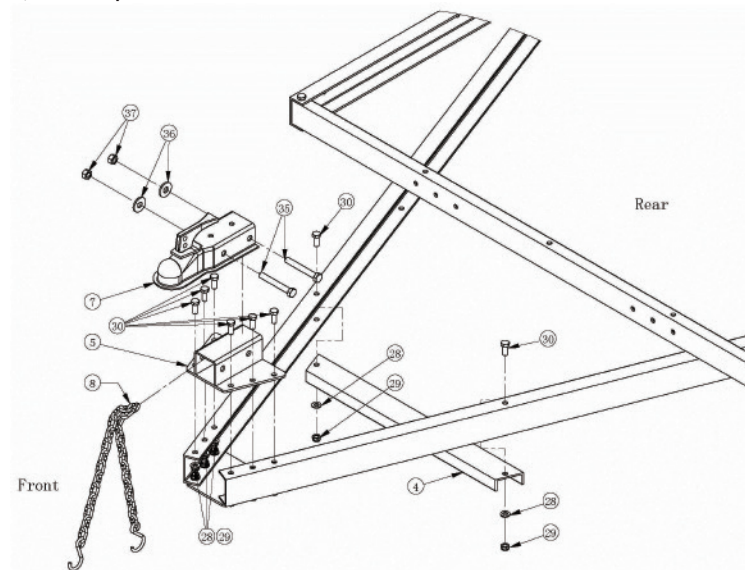

22. Lock coupler trigger using safety pin (41) through the trigger hole then insert the R pin (42) through the end hole of safety pin to lock the coupler.

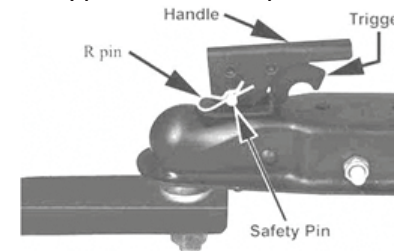

SECTION6: LIGHT SYSTEM ASSEMBLY

23. Remove the left tail light (24L) from the light bracket (25L), attach the bracket to the left side rail with M10*25 bolts, 1/2" 10 flat washer and M10 nuts (30, 28, 29 Bolt set A) as shown below. Install the left tail light and license plate holder (26) (with clear lens facing down) with M6 padded nuts (38) on the light.
24. Remove the right tail light (24R) from the light bracket (25R), attach the bracket to side right rail with M10*25 bolts, 1/2" 10 flat washer and M10 nuts (30, 28, 29 Bolt set A) as shown below. Install the right tail light with M6 padded nuts (38) on the light.
25. Attach the supporting plates(43) to the four corners of the frame and tighten with M10*25 bolts, 1/2" 10 flat washer and M10 nuts (30, 28, 29 Bolt set A).
26. Remove the lenses of the side running lights (27), feed the wire through the hole in the center of the light and the center hole in the frame and attach the lights to frame with self-tapping screws (39). Replace the lenses on the lights.

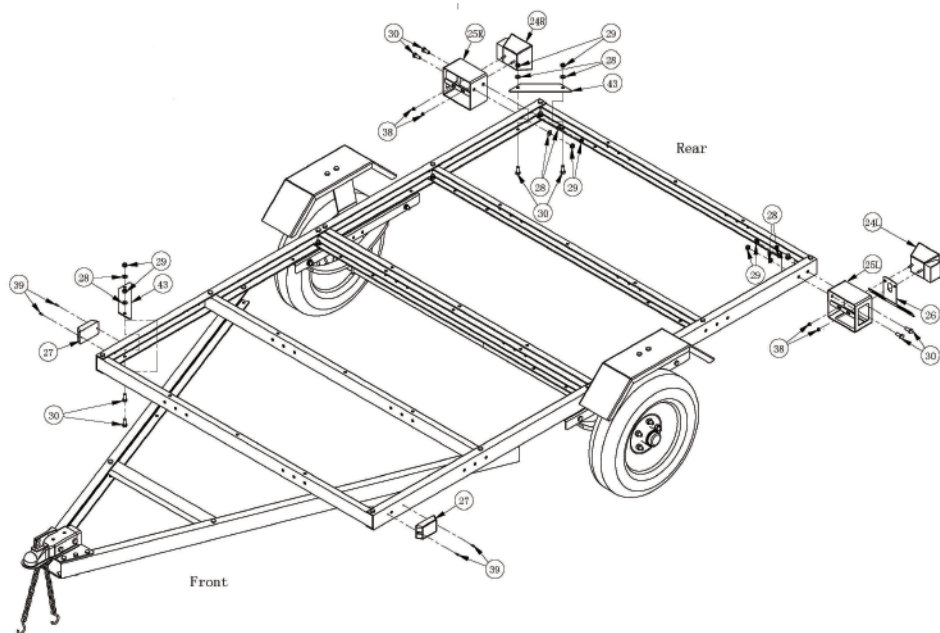

TRAILER LIGHT KIT
WINDOW DIAGRAM AND INSTRUCTION

Check alignment of all parts and install 4-wire vehicle connector in trunk area of your car. Locate the connector plug near the hitch ball and lay out wires. Connect the brown wire to tail light by stripping, wrapping and taping connector, similarly connect the yellow wire to left single & stop light wire and green wire to the right single & stop light wire. Some foreign vehicle may require an adaptor to convert their 5-wire system to 4-wire vehicle connector.

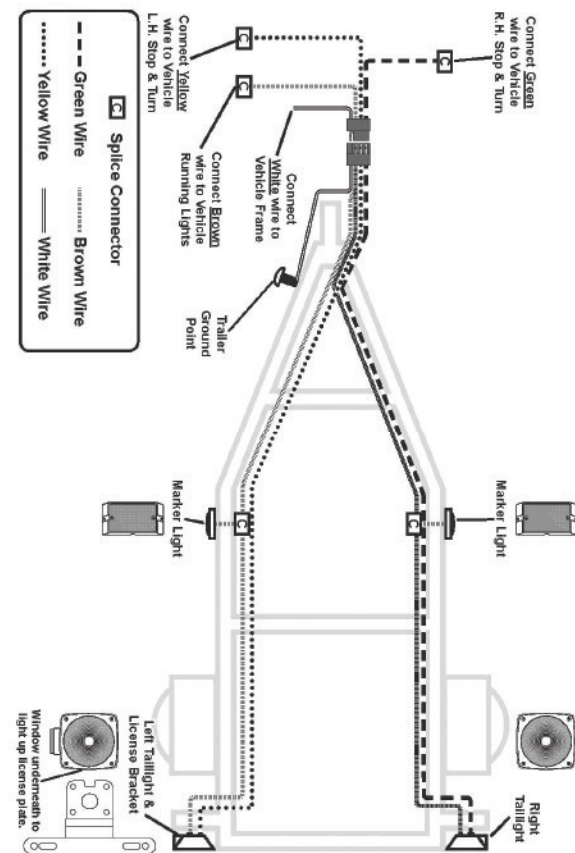

27. Attach while ground wire at plug end of wiring harness to the small hole on coupler base (15) with 4mm tapping screw.
 28. Leave about 18" of wire beyond the coupler and lay out wire to the channel of tow bar and side rail as shown. Holes wire to rail with wire clip as circle D.
 29. Connect the wire lead from the side running light to the brown wire on each side with the wire connector. Use pliers to squeeze the connector closed as circle E.
 30. Strip end of wire 3/4" for yellow / brown and green / brown wires.
 31. Make tail light connections as per color code with connector as circle C.
- | | |
|-------------------------------------|-------------------------------------|
| Left Side | Right Side |
| Yellow-yellow wire | Green-green wire |
| Brown- brown wire | Brown- brown wire |
| White- tighten with tail light bolt | White- tighten with tail light bolt |

SECTION7: ASSEMBLY CHECK

- Double-check the assembly to be sure all the steps were followed and all the parts are used. Fully tighten all bolts and nuts.
- Do not remove the VIN sticker from the tow bar.

Trailer Licensing Notice

Some states may consider that this trailer kit is and specially constructed or a homemade vehicle for registration, licensing and/or titling purposes. The M.C.O. (Manufacturer's Certificate of Origin) supplied with your trailer must be filled out and signed by the dealer transferring ownership to you. When licensing your trailer, you will need the signed M.C.O., a purchase invoice, cash register receipt, or bill of sale showing the purchase and retail sales tax or use tax collection by the retailer. Take these to your local Department of Motor Vehicles and upon payment of the appropriate State fees, you will be issued a title, registration and license plate (if required). Some states will require inspection of the assembled and finished trailer kit before issuing a title registration/license. If you require additional information or guidance on licensing or titling, please consult your State Department of Motor Vehicles.

Before Each Use

Check for loose, damaged, or cracked parts on the trailer before each use. Carefully check that the trailer will operate properly and perform its intended function, including the tire condition and pressure and correct function of the tail and side lights (see Operating Instructions below). Replace damaged or worn parts immediately. Never use the trailer even if minor damage is present.

Operating Instructions

Plan your towing, and use the correct trailer for the job. Tools do a better and safer job when used in the manner for which they are designed.

TOW VEHICLE

- Make sure the tow vehicle is capable of towing the load.
- Excess speed is the second highest cause of car-trailer accidents. Recommended maximum speed for all passenger cars towing trailers is 45 MPH.

HITCH, BALL, COUPLER

- Check that the hitch on the tow vehicle is capable of towing the trailer and load. The towing capability of the hitch is normally stamped on the hitch drawbar.
- Make sure the tow vehicle ball is the same size as the trailer coupler (2 inch) and are rated equal to, or greater than the load. Only attach the proper size ball to the coupler for towing.

SAFETY CHAINS

- Always use safety chains.
- Check that the safety chains are attached to the tow vehicle with the same length on each side.
- Always cross the chains under the coupler and connect the safety chains to the tow vehicle frame.
- Do not allow the chains to drag on the ground.

LOADING

- Never overload the trailer. Maximum load is 1715 lbs.
- Trailer load size should not exceed trailer's bed-board size (5' x 8').
- Load the trailer evenly from side to side with 60% of the load forward of the axle (see picture at right). It is important that the trailer coupler press down on the vehicle hitch, but not beyond the trailer capacity of 1715 lbs.
- Reduce the weight in the car trunk and rear seat areas by the amount of the hitch force from the trailer.
- It is unsafe and also against the law to carry passengers in any trailer.

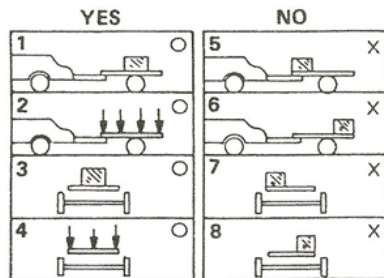

LIGHTING

- Check lighting before each use and every 100 miles to be sure the stop, tail, and turn signals are working properly. REPLACE ANY BROKEN LENSES, REFLECTORS, OR BULBS.
- Check the wires for good connections and possible fraying or wearing of insulation.
- Lights supplied with this trailer are for 12-volt DC systems only. Do not attempt to power the bulbs with any other type of voltage.

TIRES

- Check tires for wear, damage and proper inflation before each use and every 100 miles.
- Tire pressure should be kept at 60 PSI.
- Check and tighten the lug nuts. Torque to 85-90 ft.-lbs.
- Re-torque the lug nuts after the first 25, 50 and 100 miles and before each tow thereafter.

OPERATION

- Tighten the trigger lock on the coupler and hook the safety chains securely (see Safety Chains above and Coupler Operation below). After assembly and attachment, pull up and down on the hitch coupler to make sure the hitch ball is snug in the hitch coupler. If the coupler is not secured properly, it could come loose while the trailer is in motion, causing property damage, serious personal injury or even death.
- Know how to properly control your tow vehicle-trailer combination on the highway under all conditions. Remember the loaded weight of the trailer will increase your braking and stopping distances appreciably.
- DO NOT allow anyone to ride on the trailer.
- Make wide turns when towing a loaded trailer, avoiding both sharp turns and U-turns. Turning too sharply can cause damage to the trailer and/or the tow vehicle.
- **CAUTION:** Care must be taken when backing up the trailer; only back up the trailer on a straight path. The trailer could jackknife if allowed to turn off the straight path while backing up and possibly cause severe damage to the trailer and the tow vehicle.
- When towing a trailer over long distances, stop and check the tightness of all connections, lights, and running gear every 100 miles.
- Carry emergency flares, and a fire extinguisher if required for operation in your state.
- It is recommended to carry extra bulbs and fuses if you are towing the trailer at night or over any great distance.
- Whenever possible, park the trailer on a flat, level, paved surface and chock both tires to keep the trailer from unexpectedly moving.

COUPLER OPERATION

1. Temporarily remove the "R" pin and safety pin. Then, pull up on the trigger and lift up on the handle. **NOTE:** To reduce friction between the hitch ball and coupler, apply a layer of heavy weight grease over the hitch ball.
2. With assistance, place the trailer coupler over the vehicle's hitch ball and pull back on the trigger and push down on the handle until the trigger locks in the slot.
3. Pull up and down on the coupler to make sure the hitch ball fits snugly in the coupler. There should be no play between the hitch ball and coupler. **IMPORTANT:** If there is play, tighten the adjustment nut (shown below, right) until no play is present – after unlocking the handle, the nut retaining plate (holding the adjusting nut in place) needs to be pressed back while the nut is tightened. After the nut is tightened, the retaining plate needs to be fit in place against the flats of the nut to prevent it from moving. This adjustment should be done by two people. If the adjustment nut is too tight, the handle will not lock. After an adjustment of the nut, repeat steps 2 and 3 to properly attach the hitch and coupler.
4. Replace the safety pin and the "R" pin.

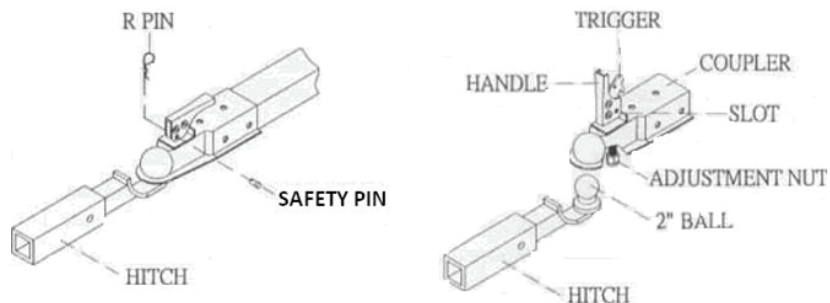

After Each Use

Check for damaged or cracked parts on the trailer after each use, including the tire condition and pressure. This way replacement parts can be purchased and replaced before the next use. Wash off the trailer to prevent dirt and road grime from hardening on the components.

Maintenance

Maintain your trailer. It is recommended that the general condition of any tool be examined before it is used. Keep your tool in good repair by adopting a program of conscientious repair and maintenance including the following points:

- Use only identical replacement parts on the trailer. Parts that may be suitable for a different trailer may create a risk of injury when used with this trailer.
- Check and maintain the trailer, coupler, ball and hitch before each use and every 200 miles.
- To prevent bearing damage, disassemble and repack the wheel bearings with a good grade of wheel bearing grease every 2000-3000 miles or yearly. If you do not know how to repack wheel bearing, take your trailer to a qualified service technician.
- When servicing the trailer, check that the tire pressure is 60 PSI when the tires are cold. Refill the tire with air as needed.

Store the trailer when it is not in use. Inspect the trailer for good working condition prior to storage and again before re-use.

Parts Diagram & parts list

Part No.	Description	Q'ty	Part No.	Description	Q'ty
1L	Left side rail	1	23	M12 hub lug nut	10
1R	Right side rail	1	24L	Left LED tail light	1
2	Cross member	6	24R	Right LED rail light	1
3	Tow bar	2	25L	Left light bracket	1
4	Spare tire bar	1	25R	Right light bracket	1
5	Coupler base	1	26	License plate holder	1
6	Stand base	1	27	Side running light	2
7	2" coupler	1	28	∅ 10 flat washer	68
8	Safety Chain	1	29	M10 nylon lock nut	68
9	Axle	1	30	M10x25 bolt	58
10	5 stub hub	2	31	M10x80 bolt	2

Part No.	Description	Q'ty	Part No.	Description	Q'ty
11	T3 leaf spring	2	32	M14x80 bolt	2
12	Bearing	4	33	∅ 14 flat washer	2
13	Washer	2	34	M14 nylon lock nut	2
14	Castle nut	2	35	M12x90 bolt	2
15	Cotter pin for spindle	2	36	∅ 12 flat washer	2
16	Dust cap	2	37	M12 nylon lock nut	2
17	Spring hanger	2	38	M6 padded nut	4
18	Spring plate	2	39	M4x12 self-tapping screw	4
19	U bolt	4	40	Hub grease fitting	2
20	Aluminum fender	2	41	Coupler safety pin	1
21	Fender seat	2	42	Coupler R pin	1
22	530-12 tire and wheel assembly	2	43	Supporting plate	4

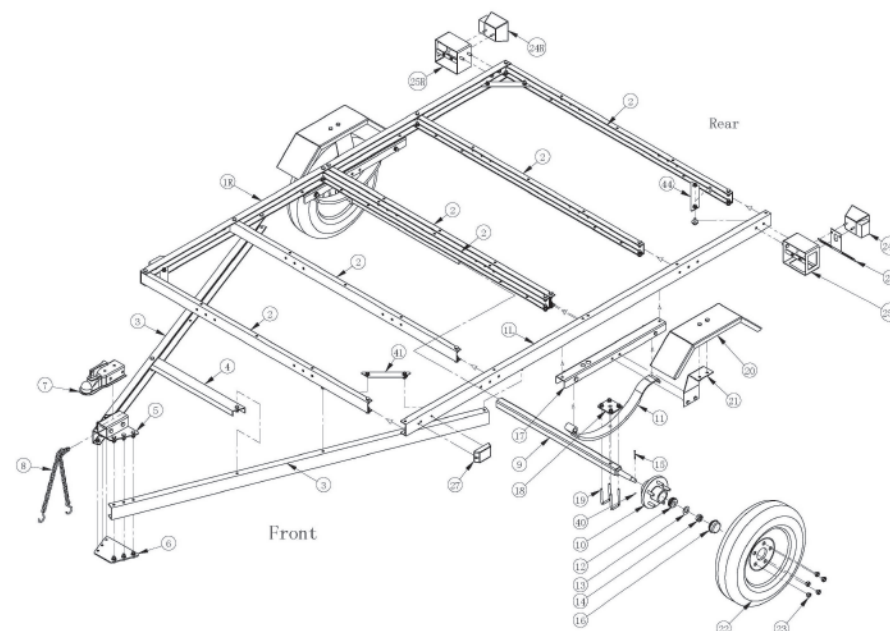

Replacement Parts

- For replacement parts and technical questions, please call Customer Service at 1-800-222-5381.
- Not all product components are available for replacement. The illustrations provided are a convenient reference to the location and position of parts in the assembly sequence.
- When ordering parts, the following will be required: Model Number, Serial Number/Lot Date Code, and Description.
- The distributor reserves the rights to make design changes and or improvements to product lines and manuals without notice.

Limited Warranty

Northern Tool and Equipment Company, Inc. ("We" or "Us") warrants to the original purchaser only ("You" or "Your") that the Ultra Tow product purchased will be free from material defects in both materials and workmanship, normal wear and tear excepted, for a period of one year from date of purchase. The foregoing warranty is valid only if the installation and use of the product is strictly in accordance with product instructions. There are no other warranties, express or implied, including the warranty of merchantability or fitness for a particular purpose. If the product does not comply with this limited warranty, Your sole and exclusive remedy is that We will, at our sole option and within a commercially reasonable time, either replace the product or product component without charge to You or refund the purchase price (less shipping). This limited warranty is not transferable.

Limitations on the Warranty

This limited warranty does not cover: (a) normal wear and tear; (b) damage through abuse, neglect, misuse, or as a result of any accident or in any other manner; (c) damage from misapplication, overloading, or improper installation; (d) improper maintenance and repair; and (e) product alteration in any manner by anyone other than Us, with the sole exception of alterations made pursuant to product instructions and in a workmanlike manner.

Obligations of Purchaser

You must retain Your product purchase receipt to verify date of purchase and that You are the original purchaser. To make a warranty claim, contact Us at 1-800-222-5381, identify the product by make and model number, and follow the claim instructions that will be provided. The product and the purchase receipt must be provided to Us in order to process Your warranty claim. Any returned product that is replaced or refunded by Us becomes our property. You will be responsible for return shipping costs or costs related to Your return visit to a retail store.

Remedy Limits

Product replacement or a refund of the purchase price is Your sole remedy under this limited warranty or any other warranty related to the product. We shall not be liable for: service or labor charges or damage to Your property incurred in removing or replacing the product; any damages, including, without limitation, damages to tangible personal property or personal injury, related to Your improper use, installation, or maintenance of the product or product component; or any indirect, incidental or consequential damages of any kind for any reason.

Assumption of Risk

You acknowledge and agree that any use of the product for any purpose other than the specified use(s) stated in the product instructions is at Your own risk.

Governing Law

This limited warranty gives You specific legal rights, and You also may have other rights which vary from state to state. Some states do not allow limitations or exclusions on implied warranties or incidental or consequential damages, so the above limitations may not apply to You. This limited warranty is governed by the laws of the State of Minnesota, without regard to rules pertaining to conflicts of law. The state courts located in Dakota County, Minnesota shall have exclusive jurisdiction for any disputes relating to this warranty.

ULTRA-TOW™

Distributed by
Northern Tool + Equipment Co., Inc.
Burnsville, MN 55306
NorthernTool.com
Made in China