

'S' Pumps

OPERATOR'S MANUAL & PARTS LIST

for Self-priming Centrifugal Pumps

Before reading or using this manual be certain of the material of construction of your pump. Check the model number label as follows:

POLYESTER pumps have model numbers beginning with SE
POLYPROPYLENE pumps have model numbers beginning with SP
RYTON® pumps have model numbers beginning with SY



SAFETY WARNING

Verify the chemical compatibility of the materials of your pump with the liquid you want to pump. If you are uncertain regarding the chemical compatibility contact your dealer for applications assistance and request a copy of our corrosion resistance charts. Do not use a pump that is not chemically compatible with the liquid you intend to pump or serious bodily injury, death, fire, explosion or environmental damage could result.

ALSO, PLEASE READ SECTIONS I, II AND III BEFORE OPERATING PUMP.

page no.

I. Safety precautions	2
II. Preparing the pump for operation	3
III, Pump Operating Instructions	4

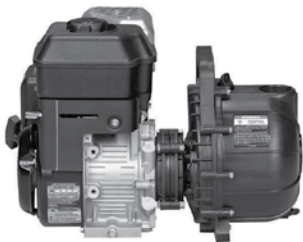

Gasoline Engine Drive with
PROTEK System



Pedestal Mount



Hydraulic Drive
Close Coupled



Gasoline Engine Drive
Close Coupled



Electric drive Close Coupled



Gasoline Engine Drive with
Optional Roll Cage

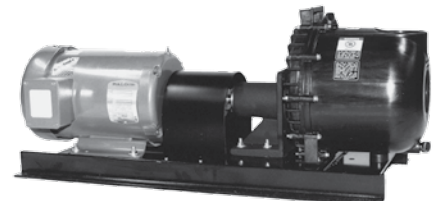

Electric Drive long-coupled



SAFETY WARNING

Verify the chemical compatibility of the materials of your pump with the liquid you want to pump. If you are uncertain regarding the chemical compatibility contact your dealer for applications assistance and request a copy of our corrosion resistance charts. Do not use a pump that is not chemically compatible with the liquid you intend to pump or serious bodily injury, death, fire, explosion or environmental damage could result.

OPERATOR'S MANUAL FOR SELF PRIMING CENTRIFUGAL PUMP

Table of contents

Please read sections I, II and III before operating pump page no.

I. Safety Precautions	2
II. Preparing the Pump for Operation	2
III. Pump Operating Instructions	3
IV. Pump Trouble Shooting and Repair	3
V. Pump Disassembly and Repair	4
VI. Special Information: A. Flexible - Coupling: Coupling alignment.....	4
1. Couplings	
VII. Pump Parts List and Parts Diagram	5-6
VIII. Pump Accessories and Options List	7

OPERATOR'S MANUAL

I. SAFETY PRECAUTIONS

WARNING:

- Never use these pumps for pumping flammable liquids such as gasoline. AN EXPLOSION AND SERIOUS INJURY MAY RESULT IF THIS WARNING IS IGNORED.
- In pumping corrosive materials, extreme caution should be exercised. Provide safety guards, ventilation and drains to protect people and property in case of a leak in the pump. Handling instructions from the manufacturer(s) of the liquids being pumped should be closely followed. See Page 8.
- Before starting the pump, follow all of the instructions in this manual and any supplemental instructions supplied with the pump.
- Any person operating the pump and its power unit should be fully aware of its safe operation before they start using it.
- Never operate an engine driven unit in an explosive atmosphere, near combustible materials or where insufficient ventilation exists unless specific provisions have been made regarding the power unit so as to prevent possible injury and damage. Be certain any other power unit is safe for the area in which it is to be operated.
- Always be sure that the pump is on secure footing so that it can not slide, shift or tip over. If the pump is sitting beside a pit, secure it so that it does not fall in. Pump and engine units have slots and holes for fastening to a secure base. Base rail, skid (rail) and roll cage kits are available from your pump dealer.
- Never operate the unit with any guards removed.
- With engine driven pumps:
 - In refueling engine, observe all safety precautions for the handling of the fuel.
- Never refuel the engine while it is running. Care should be exercised so that no fuel is spilled on a hot engine. Always allow engine to cool at least two minutes before refueling.
- Before working on this pump make sure that the power unit cannot inadvertently be started.
- Be sure that the power unit, pump, wiring and piping installations are suitable for the liquid being pumped. Comply with all applicable codes and regulations.
- Do not use torches or apply fire or flames to this pump for any reason.
- This pump must not be subjected to more than 65 pounds per square inch internal pressure for polyester pumps... 55 psi for Rytol® and polypropylene pumps. The pump itself normally cannot develop more than 55 pounds per square inch pressure. The conditions must not be used under any of the following unusual conditions which can result in excessive pressures being developed:
 - Pump shaft speed over 3600 RPM.
 - Quick closing valves in suction or discharge line or any other device which may introduce hydraulic shock to the system.
 - Possible sudden obstruction of discharge line such as vehicle driving over hose.
 - High positive suction pressures (such as with a flooded suction) which would increase the total system pressure to 65 PSI or above... 55 psi maximum for polypropylene and Rytol® pumps.

- Do not pump liquids with specific gravities exceeding the following values:

Impeller Number	Maximum Specific Gravity* at 3450 rpm	
	Polyester - Polypropylene - Rytol®	1.5
58-0667	1.8	1.5
58-0704	1.3	1.1
58-0706	1.2	1.0
58-0974	1.8	1.5
58-0975	1.8	1.5

*The specific gravity is the ratio of the weight of the liquid to be pumped to the weight of an equal volume of water. Water has a specific gravity of 1.0 therefore, a liquid which is heavier than water has a specific gravity greater than 1.0.

- Do not overtighten the drain or filler plugs. Hand tighten only. Excessive force may damage the threads of the pump body. Do not use metal plugs.
- Use at least one foot of flexible hose to make plumbing connections to the pump body. Rigid piping may put stresses on the pump, causing damage. If rigid piping must be used, properly support it so as to eliminate stresses to the pump.



II. PREPARING THE PUMP FOR OPERATION

CAUTION! Fill With Liquid Before Operating Pump. Do Not Open When Pump Is Operating.

- Pump Preparation**
 - Inspect unit for shipping damage immediately upon receipt and before signing for merchandise. If any visible damage exists, note damage on shipping bill of lading or receiving document(s) before signing. Also notify your dealer or distributor immediately of any damage to the shipment.
 - Read these instructions and the power unit instructions until you are sure you can operate it safely and correctly.
 - IMPORTANT INFORMATION ABOUT PUMP ELASTOMERS ("RUBBER PARTS").**

BUNA-N ELASTOMERS
This pump is equipped with Buna-N elastomers ("rubber parts"). Buna-N material is suitable for use with water (clean and dirty) and other non-hazardous liquids. Consult factory for additional specific non-hazardous application recommendations.

EPDM ELASTOMERS
This pump is equipped with EPDM shaft seal and EPDM static seals. The elastomers ("rubber parts") are suitable for use with water (clean or dirty) and many non-hazardous agricultural and industrial chemicals. Consult the factory for specific non-water application recommendations.

VITON ELASTOMERS
This pump is equipped with Viton elastomers ("rubber parts"). Viton material is suitable for use with water (clean or dirty), and many non-hazardous agricultural and industrial chemicals. However, due to the wide range of chemical solutions, it is not possible to list them all here. Consult the factory for specific non-water application recommendations.

- Do not tighten inlet and discharge fittings more than one turn beyond hand tight. Excessive force will damage the fittings.

Use teflon sealing tape on all threaded fittings.

- Long suction and discharge hoses or pipes must be supported so that the weight of the hoses or pipes filled with liquid does not drag or tip the pump over.
- Use replacement parts supplied by the manufacturer only.
- Do not run the pump dry. Always fill the pump body with the liquid to be pumped before starting the pump. It is not necessary to drain the pump body after use, unless there is danger of freezing, settling of solids or crystallization.
- Do not restrict flow through the pump such as with a closed discharge valve or "starved" suction line. Harmful heat build up will result. If it is necessary to restrict flow through the pump for longer than five minutes, either the pump must be stopped or a discharge bypass line installed to keep liquid temperatures below the maximum recommended operating temperatures.
- Do not subject pump to extreme conditions of acidity or basicity. Consult factory for specific recommendations concerning chemicals and temperature.

- Power unit preparation-Gasoline engine driven pumps:**
 - For complete operating and maintenance information consult the engine manufacturer's instructions included with the pump.



OIL

- BEFORE STARTING FILL CRANKCASE WITH OIL SPECIFIED BY THE ENGINE MANUFACTURER.** Use a high quality detergent SAE 30 oil classified for service SF, SH, SJ or higher. Do not add anything to the recommended oil.



FUEL

- Before starting, fill fuel tank with clean, fresh, unleaded grade automotive gasoline. DO NOT mix oil with gasoline. Refer to engine manufacturer's operating manual for further instructions.

CAUTION: Always remove spark plug or spark plug wire before working on unit to prevent accidental starting.

CAUTION: The engine governor is set at the factory. Do not tamper with any part which may increase the governed engine speed.

WARNING

The engine exhaust from this product contains chemicals known to the state of California to cause cancer, birth defects or other reproductive harm

NOTE: Reducing pipe size will drastically reduce pump performance and can damage pump if overly restricted. The suction line should always be the same size or larger than the discharge line. For optimum pump performance the pipe size should remain the same as the port sizes.

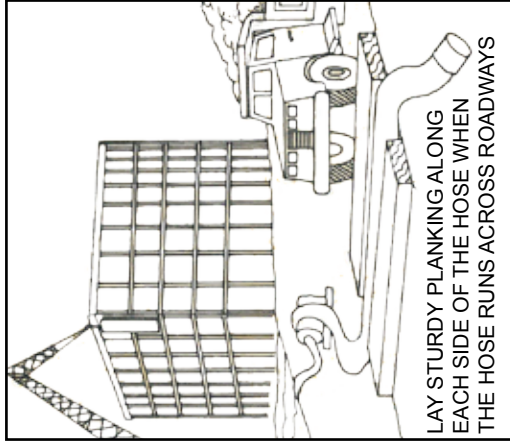
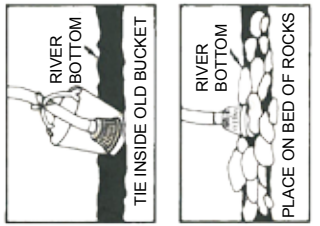

FIGURE 2

IV. PUMP TROUBLESHOOTING AND REPAIR



SUGGESTED WAYS TO KEEP STRAINER OUT OF RIVER SILT

D. Power unit preparation - Hydraulic and Pneumatic motors:

Consult the separate instruction sheet supplied with each hydraulic or pneumatic motor powered unit.

Power requirements:

NOTE: For liquids having specific gravities greater than 1.0, increase the rated horsepower (from catalog) by a factor equal to the specific gravity of the liquid being pumped. (Ex. Catalog HP x Specific gravity = Actual HP required)

III. PUMP OPERATING INSTRUCTIONS

A. Fill the pump body with liquid before starting.

Do not run the pump dry; damage to the seal may result. There are no points on the pump which need lubrication. The shaft seal is self lubricating, and is designed to handle clean liquids.

B. Make certain that all hose and pipe connections are air tight. IMPORTANT: An air leak in the suction line may prevent priming, and will reduce the capacity of the pump.

C. Always place the pump as close as possible to the liquid to be pumped. Keep all lines as short and straight as possible. Avoid sharp bends in the hoses. Keep the pump on a level foundation. See Figure #1.

D. If flexible hoses must be laid across a roadway, protect it with planking. Instantaneous shut-off pressures applied when a vehicle runs across an unprotected hose will cause "hydraulic shock". This shock can damage the pump and/or damage the hose. See Figure #2.

C. Power unit preparation - Electric Motors

1. Make certain the input power to your electric motor is proper, single phase or three phase, and is of the proper voltage according to the motor specification plate.
2. Be sure of the proper motor rotation. Pump impeller should rotate counterclockwise, looking from the suction inlet side. For single phase motors consult the motor manufacturer's for wiring for counterclockwise rotation. Three phase motor rotation may be reversed by interchanging any two of the three power leads.
3. Make certain that wiring for your electric motor complies with all existing codes.

E. When pumping dirty water or other liquids which may contain solids, always use a pump strainer on the end of the suction line specified by the manufacturer. If the suction strainer is likely to clog with dirt and debris, do one of the following:

- (a) Prepare a bed of rocks on which to rest the strainer. (See Figure #3)
- (b) Tie the strainer so that it stays off the bottom of the pit, excavation, etc.
- (c) Tie the strainer inside a basket or pail. (See Figure #3)

F. Drain the pump body whenever there is a danger of freezing.

G. Always use rubber feet under portable pump when operating on a hard surface. This will prevent damage to the pump and power unit.

H. Always flush out the pump at the end of operation if the liquid being pumped may leave a solid or sticky residue in the pump. If this is not done, damage to the pump may result.

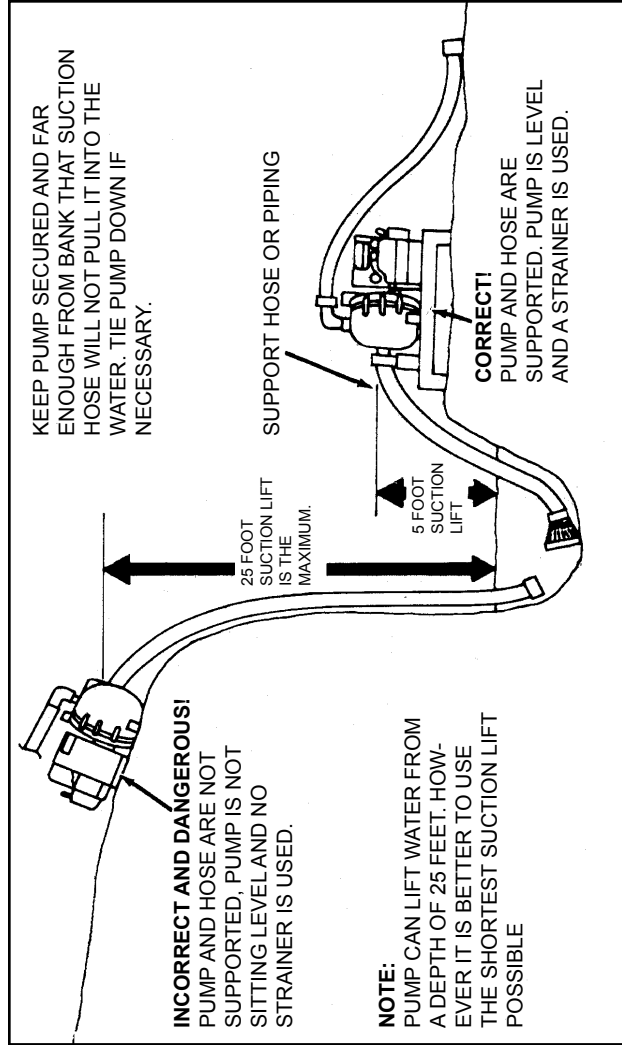
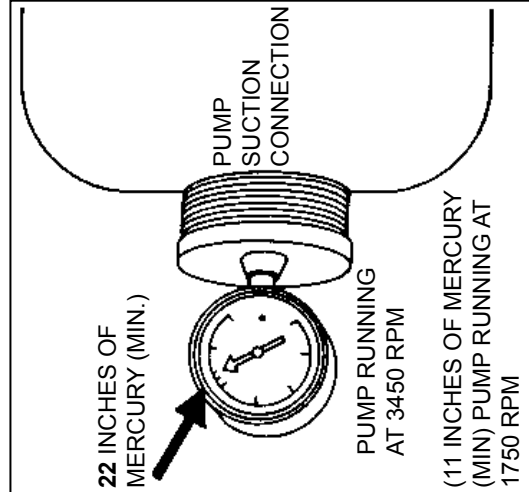

FIGURE 4

DIAGNOSIS

A. Does not prime or does not pump



B. Pump has insufficient flow

TREATMENT

1. Fill the pump with clean liquid and try pumping again.
2. Shut off power source to the pump. Shut off valves to and from pump. While observing all safety precautions for the liquid being pumped, disconnect suction and discharge lines and drain the pump completely. Fill the pump with water. Install a vacuum gauge in the suction port (See Figure #4). Turn on power source. Vacuum should exceed 22 inches of mercury when pump shaft is rotating at 3450 RPM and should equal or exceed 11 inches of mercury with pump shaft at 1750 RPM. If vacuum is below these values, check the following:
 - a. Leak at suction fitting.
 - b. Pump rotation, impeller should rotate counter clockwise when viewing through suction end.
 - c. Pump speed. (Maximum vacuum performance drops off rapidly with decreasing RPM).
 - d. Sealing of check valve gasket between body and volute.
 - e. Check for worn impeller or volute. If necessary, replace these parts. (See items B.5, B.6 and B.7 of section V)
 - f. Worn shaft seal.
3. If pump suction tests ok, attach suction line and check suction at end of suction line. Failure to get suction here indicates leaking connections, leaking hoses, pipes or obstruction in the lines. Liners of suction nose will occasionally collapse inside the hose.

1. Check the items as in 1,2 and 3 above.
2. Replace any worn or broken components; check clearance between impeller vanes and volute face (See section V #B.5).

V. PUMP DISASSEMBLY AND REPAIR

- A. DISASSEMBLY**
- Remove the ten 1/4"-20 body screws. Remove the pump body.
 - Remove the rubber check valve from the volute and the large O-ring from around the perimeter of the bracket.
 - Remove the volute.
 - Unscrew the impeller screw and remove it along with the small O-ring. Slide the impeller and the key off the shaft. (to facilitate removal of the impeller, gently force two screw drivers 180 degrees apart, under the back of the impeller and gently pry the impeller off the shaft.)
 - One half of the shaft seal is in the impeller hub, and the other half is around the shaft, inside the bracket. The impeller portion of the seal can be carefully pried out with a screwdriver. If you plan to reuse the seal, be careful not to nick or scratch either of its flat polished surfaces.
 - Remove the four bracket screws* and the small O-rings on each screw and remove the 9" O-ring segment which forms an arc over the shaft seal. Pull the bracket off the engine. The stationary half of the shaft seal can now be pressed out from the back side the bracket. Use a round wooden plug 1-3/16 in diameter and carefully press the seal out straight if it might be reused. (Be careful not to damage the seal face).
Remove the O-ring from around the seal.
*NOTE: if plugs are installed over the bracket screws on your pump remove the plugs by screwing a body screw into the hole and carefully pulling them out.

B. ASSEMBLY

- Put all parts back together in the reverse of the order used in disassembly.
- When installing a new seal, always replace both elements of the seal and put the O-ring in place around the bracket half of the seal. Protect the smooth lapped sealing surfaces from damage when pressing in the new parts. To press the bracket portion of the seal in place, use a piece of pipe that will bear only on the flange of the metal seal case. Be sure both seal halves are fully seated and square with respect to the pump shaft.
- During the final assembly, it is recommended that all of the screw head O-ring seals (item #8, fig. 7) be replaced. Lubricate these with vegetable oil (*DO NOT* use petroleum base oil) before assembly.

threads with teflon sealing tape. Proper tightness is hand tight plus one full turn with a pipe wrench.

CAUTION: After pump is assembled and before starting, rotate the shaft by hand and listen for possible scraping noises.

VI. SPECIAL INFORMATION

A. FLEXIBLE COUPLED PUMPS:

COUPLING ALIGNMENT

Measure the diameter of the pump shaft and power unit shaft. Choose the appropriate coupling for your pump and power unit. (See flexible couplings chart VI-A). Proper shaft and coupling alignment reduces vibration and prevents premature coupling failure. The following 8 steps help in obtaining proper shaft alignment:

- Make sure you use a rigid base plate large enough for the assembly of the pump and the drive unit. We offer kits, 58-0028 and 58-0016, for this purpose. (See base plate kits listed after couplings chart VI-A)**
- Place the pump and drive unit on the baseplate.
- Measure the distance between the centerline of the of the pump shaft and the baseplate surface.
- Measure the distance between the centerline of the drive unit shaft and the baseplate.
- Compare measurements obtained from steps 3 and 4 and use spacer blocks for height adjustment to ensure alignment of both shafts.

6. Place the coupling halves over each shaft. Put the "spider" between the two halves and couple the two halves together.

7. To assure parallel alignment (Figure 5) place a straight edge along the side of

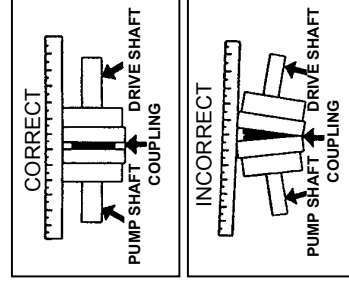

FIGURE 5

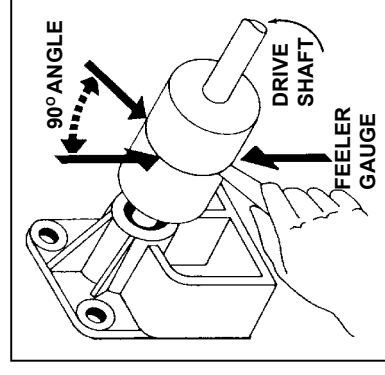

FIGURE 6

COUPLING PART NUMBER	POWER UNIT SHAFT* DIAMETER	ELECTRIC MOTOR FRAME SIZES
58-0786	.652"	56
58-0786	.875"	143T-145T 182-184
58-0787	1.125"	183T-184T
58-0788	1.375"	213T-215T
58-0875	1"	213-215
58-0876	.75"	-----

FLEXIBLE COUPLING CHART VI-A
* One half of each coupling has a .750" diameter bore to fit the pedestal pump shaft.

A scraping noise indicates improper clearances, requiring disassembly and reshimming.

12. With pump running and with pump body full of water, put a vacuum gauge over the suction opening and check suction ability according to section IV.

both coupling halves in two different locations, 90 degrees apart. The coupling is aligned when the straight edge rests squarely in the sides of both coupling halves.

8. To avoid angular misalignment, insert a measuring device (taper gauge or feeler gauge) between the coupling faces at four locations 90 degrees apart. (See arrows in Figure 6) and measure the gap at each of the four locations. For proper alignment all four measurements should be equal. Reshimming may be required to achieve this alignment.



SELF-PRIMING CENTRIFUGAL PUMP - "S" SERIES

PARTS LIST
PP-9900-J
June 2013

NOTE 1: You will note a multiple choice of impellers, volutes, and top volute screws. Once you have identified the impeller (from the pump model no., or by comparing your impeller to the descriptions given the various impellers) you can make your choice of impeller, volute, or volute screws by following the same letter grouping. For example: if your impeller is black, open type, 5 vane, .535" wide, then it is part no. 58-0706 30 and has an "A" designation, under the column marked "Group". You now choose the proper top volute screw (ref no. 19, as required).

NOTE 2: Impellers (ref. no. 15) may be ordered with the seal (ref. no. 14) installed. The part no. for these assemblies is the same as the impeller part no. except that the last digit is a "1" for Buna-N seal, a "2" for EPDM and a "3" for Viton seal. For example: Assembly 58-0704 31 consists of impeller 58-0704 30 (ref. no. 15) and a Buna-n seal half (ref. no. 14).

NOTE 3: Bracket assemblies are available with the shaft seal (ref. no. 13), shaft seal O-ring (ref. no. 11) and O-ring segment (ref. no. 10) installed. For example: in Buna order 58-0703 31, EPDM order 58-0703 32, and Viton, order 58-0703 34.

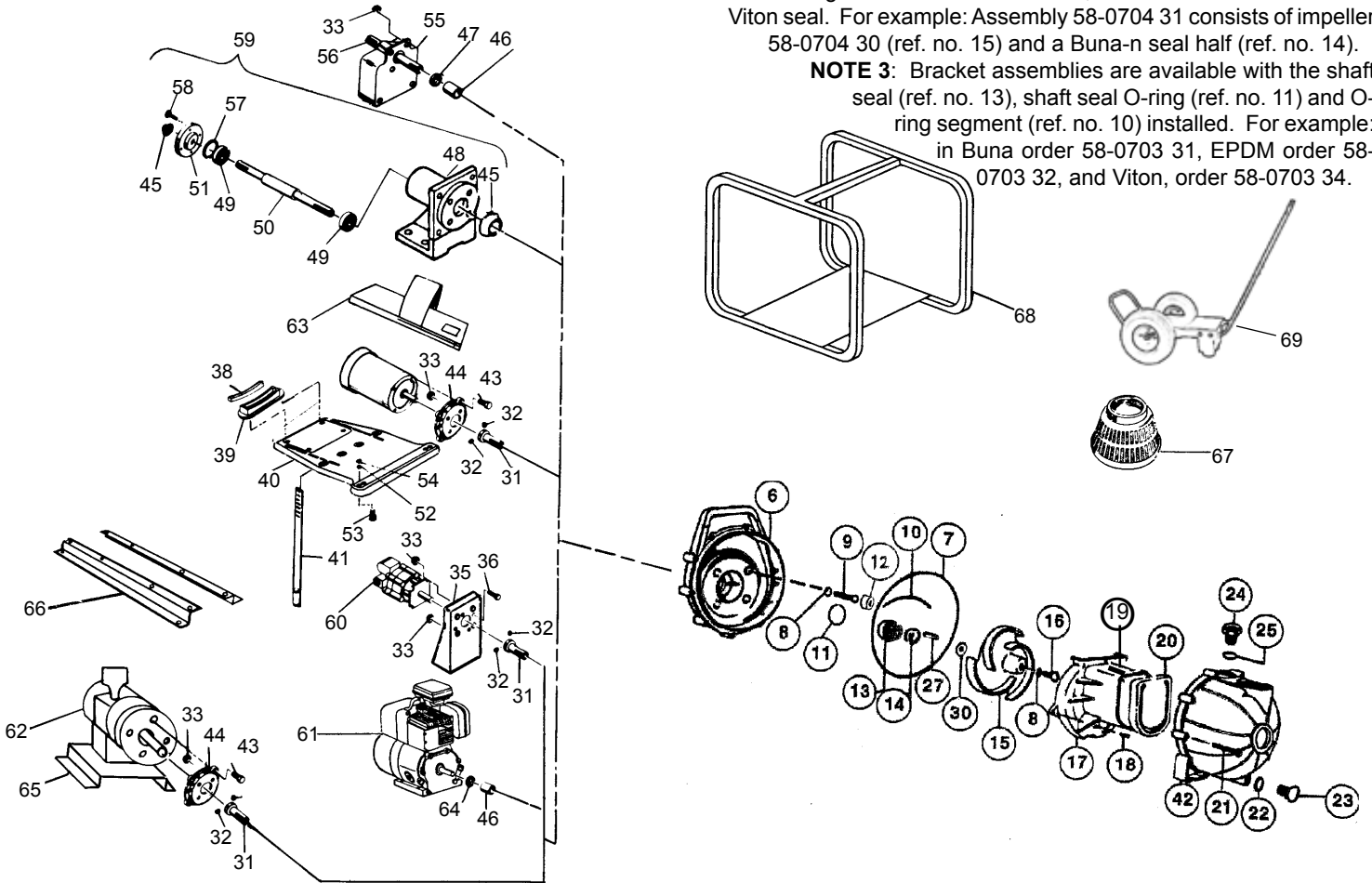

PUMP PARTS LIST

ITEM #	PART #	PART DESCRIPTION	QTY./PUMP	ITEM #	PART #	PART DESCRIPTION	QTY./PUMP
6	58-0703 30B	BRACKET, Polyester, Black	1	11	58-0976 71	O-RING, Shaft Seal, BUNA-N	1
	58-0703 40	BRACKET, Polypropylene, grey	1		58-0976 72	O-RING, Shaft Seal, EPDM	1
	58-0703 60	BRACKET, Ryton, brown	1		58-0976 73	O-RING, Shaft Seal, VITON	1
7	58-0719 71	O-RING, Body, BUNA-N	1	12	58-1750 90	PLUG, Bracket Screw (non-metallic only)	4
	58-0719 72	O-RING, Body, EPDM	1	11,13,14	58-0714 11	SEAL, Shaft, BUNA-N, 316 S.S.,carbon/ceramic	1
	58-0719 73	O-RING, Body, VITON	1		58-0714 12	SEAL, Shaft, EPDM, 316 S.S.,carbon/ceramic	1
8	58-0717 71	O-RING, Screw, BUNA-N	5		58-0714 14	SEAL, Shaft, VITON, 316 S.S.,carbon/ceramic	1
	58-0717 72	O-RING, Screw, EPDM	5		58-0714 15	SEAL, Shaft, Hastelloy C, Teflon, silicon carbide	1
	58-0717 73	O-RING, Screw, VITON	5		58-0714 92SG	SEAL, Shaft, Non-Metallic, ECTFE, EPDM siliconized graphite	1
9	58-0715 10	SCREW, Bracket, stainless steel for pumps close-coupled to engine and cast ped. mount, 5/16"-24 x 1.25"	4		58-0714 94SG	SEAL, Shaft, Non-Metallic, ECTFE, VITON siliconized graphite	1
	58-2167 10	SCREW, Bracket, stainless steel for pumps pedestal mounted (plastic), close-coupled to electric, hydraulic or pneumatic motor, 5/16"-18 x 1.5"	4		58-0891 92SG	SEAL, Shaft, Kynar, Polypro, Hastelloy C, EPDM, silicon carbide	1
10	58-0754 71	O-RING, Segment, BUNA-N	1		58-0891 94SG	SEAL, Shaft, Kynar, Polypro, Hastelloy C, VITON, silicon carbide	1
	58-0754 72	O-RING, Segment, EPDM	1		58-46250 11	SEAL, Shaft, BUNA-N, 316 SS, silicon carbide	1
	58-0754 73	O-RING, Segment, VITON	1		58-46250 12	SEAL, Shaft, EPDM, 316 SS, silicon carbide	1
					58-46250 13	SEAL, Shaft, VITON, 316 SS, silicon carbide	1

"S" SERIES PUMP PARTS LIST

PP-9900-J

ITEM #	PART #	GROUP	PART DESCRIPTION	QTY./PUMP	ITEM #	PART #	PART DESCRIPTION	QTY./PUMP
15	58-0704 30	A	IMPELLER, 3 Vane, .535" wide 5.5" dia., Polyester, black	1	30	58-1837 11	SHIM, .006", S.S. (8hp only)	as required
	58-0704 40	A	IMPELLER, 3 Vane, .535" wide 5.5" dia., Polypropylene, grey	1		58-1837 12	SHIM, .015", S.S. (8hp only)	as required
	58-0704 60	A	IMPELLER, 3 Vane, .535" wide 5.5" dia., Ryton, brown	1		58-1837 13	SHIM, .030", S.S. (8hp only)	as required
	58-0706 30	A	IMPELLER, 5 Vane, .535" wide 5.5" dia., Polyester, black	1	31	58-1014 10	ADAPTER, shaft, for close-coupled electric or pneumatic motor, stainless steel, .625" bore	1
	58-0706 40	A	IMPELLER, 5 Vane, .535" wide 5.5" dia., Polypropylene, grey	1		58-1165 10	ADAPTER, S.S., for hydraulic motor, .563" bore	1
	58-0706 60	A	IMPELLER, 5 Vane, .535" wide 5.5" dia., Ryton, brown	1	32	58-0883	SET SCREW, 1/4"-20 x .25" long, steel	2
	58-0974 30	B	IMPELLER, 4 Vane, .600" wide 4.75" dia., Polyester, black	1	33	58-0745 10	NUT, FLANGE 5/16"-18, stainless steel	4
	58-0974 40	B	IMPELLER, 4 Vane, .600" wide 4.75" dia., Polypropylene, grey	1	35	58-1011 20	PEDESTAL, hydraulic motor, molded plastic	1
	58-0974 60	B	IMPELLER, 4 Vane, .600" wide 4.75" dia., Ryton, brown	1	36	58-0729 10	SCREW, for mounting hydraulic motor to pedestal, 5/16"-18 x 1.0" long, plated steel	4
	58-0975 30	C	IMPELLER, 4 Vane, .975" wide, 4.75" dia., Polyester, black	1	38	58-1826 71	PAD, Rubber, Saddle	1
	58-0975 40	C	IMPELLER, 4 Vane, .975" wide, 4.75" dia., Polypropylene, grey	1	39	58-1828 90	SADDLE, Electric motor, 6-5/8" dia. motor	1
	58-0975 60	C	IMPELLER, 4 Vane, .975" wide, 4.75" dia., Ryton, brown	1		58-1825 90	SADDLE, 5-11/16" diameter motor	1
	58-0667 30	B	IMPELLER, 3 Vane, .535" wide, 4.75" dia., Polyester, black	1	40	58-1823 40	BASEPLATE, for close-coupled electric motors, molded plastic	1
	58-0667 40	B	IMPELLER, 3 Vane, .535" wide, 4.75" dia., Polypropylene, grey	1	41	58-0934 10	STRAP, for close-coupled electric motors, SS	1
	58-0667 60	B	IMPELLER, 3 Vane, .535" wide, 4.75" dia., Ryton, brown	1	42	58-1001 30B	BODY, 1-1/2" NPT, Polyester, black	1
	58-8706 30		IMPELLER, 5 Vane, .535" w. 5.5" d, black Polyester (8hp pumps only, 7/2003)	1		58-1001 40	BODY, 1-1/2" NPT, Polypropylene, grey	1
	58-8975 30		IMPELLER, 4 vane, .975" w x 4.75" d, black Polyester, (8hp pumps only, 7/2003)	1		58-1001 60	BODY, 1-1/2" NPT, Ryton, brown	1
16	58-0716 10		SCREW, Impeller, S.S., 5/16"-24x.75"	1		58-1002 30B	BODY, 2" NPT, Polyester, black	1
	58-1668 10		SCREW, Impeller, S.S., 3/8-24x1" (8hp only)	1		58-1002 40	BODY, 2" NPT, Polypropylene, grey	1
	58-1673 42		SCREW, Impeller, Polypropylene, EPDM	1		58-1002 60	BODY, 2" NPT, Ryton, brown	1
	58-1673 43		SCREW, Impeller, Ryton, Viton	1		58-0755 30B	BODY, 3" NPT, Polyester, black	1
	58-1673 62		SCREW, Impeller, Polypropylene, EPDM	1		58-0755 40	BODY, 3" NPT, Polypropylene, grey	1
	58-1673 63		SCREW, Impeller, Ryton, Viton	1		58-0755 60	BODY, 3" NPT, Ryton, brown	1
17	58-0702 30	A	VOLUTE, Flat, Polyester	1		58-0943 30B	BODY, 1-1/2" BSP, Polyester, black	1
	58-0702 60	A	VOLUTE, Flat, Ryton, brown	1		58-0784 30B	BODY, 2" BSP, Polyester, black	1
	58-0773 31	A	VOLUTE, Buna-N lined Polyester	1		58-0784 40	BODY, 2" BSP, Polypropylene, grey	1
	58-0773 32	A	VOLUTE, EPDM lined Polyester	1		58-0877 30B	BODY, 3" BSP, Polyester, black	1
	58-0954 30	B	VOLUTE, Flat, Polyester	1	43	58-1015 10	SCREW, hex head cap, 3/8"-16x1.25" long, S.S	4
	58-0954 60	B	VOLUTE, Flat, Ryton, brown	1	44	58-1010 20	ADAPTER, Motor, for pump close-coupled to electric or pneumatic motor, molded plastic	1
	58-0955 31	B	VOLUTE, Buna-N lined Polyester	1	45	58-1955 71	SEAL, lip, .710" ID, Buna-N	2
	58-0955 32	B	VOLUTE, EPDM lined Polyester	1		58-1955 73	SEAL, lip, .710" ID, VITON	2
	58-0977 30	C	VOLUTE, Flat, Polyester	1	46	58-0882 90	SHAFT, Sleeve, Polyethylene	1
	58-0977 60	C	VOLUTE, Flat, Ryton, brown	1	47	58-0884 71	SLINGER, Buna-N	1
	58-0978 31	C	VOLUTE, Buna-N lined Polyester	1	48	58-1951 90	HOUSING, Bearing, cast metal	1
	58-0978 32	C	VOLUTE, EPDM lined Polyester	1	49	58-1954 90	BEARING, Ball, .787" ID	2
18	58-0725 10		SCREW, side volute, S.S., #6-cc x.5" long	as required	50	58-1952 10	SHAFT, stainless steel, .75" diameter	1
19	58-0771 10	A	SCREW, top volute, S.S., #10-24x1.5"	as required		58-1952 91	SHAFT, Hastelloy, .75" diameter	1
	58-0997 10	B,C	SCREW, top volute, S.S., #10-24 x .5"	as required		58-1952 93	SHAFT, Titanium, .75" diameter	1
20	58-0705 71		CHECK VALVE, Buna-N	1	51	58-1953 10	PLATE, End, stainless steel	1
	58-0705 72		CHECK VALVE, EPDM	1	52	58-0730 10	FLAT WASHER, .563", stainless steel	2
	58-0705 73		CHECK VALVE, VITON	1	53	58-0729 10	SCREW, 5/16"-18 x 1", stainless steel	2
	58-1206 10		SCREW, Body, SS, 1/4"-20 x 2-1/8" long	10	54	58-0745 10	KEPNUT, 5/16"-18, stainless steel	2
21	58-1009 71		O-RING, Drain Plug, Buna-N	1	55	58-0759 20	BEARING Pedestal, molded plastic	1
	58-1009 72		O-RING, Drain Plug, EPDM	1	56	58-0777	BEARING, Shaft Assy., standard, carbon steel	1
	58-1009 73		O-RING, Drain Plug, VITON	1		58-0777 10	BEARING, Shaft Assy., with S.S. shaft sleeve	1
22	58-0723 30		PLUG, Drain, Polyester, black	1	55,56	58-2053 01	ASSEMBLY, Pedestal, 3/4" carbon steel shaft	1
	58-0723 40		PLUG, Drain, Polypropylene, grey	1		58-2053 02	ASSEMBLY, Pedestal, with S.S. shaft sleeve	1
	58-0723 60		PLUG, Drain, Ryton, brown	1	57	58-1956 10	SHIM, Bearing Shaft, cast metal pedestal, .006" thick	as required
23	58-0722 30B		PLUG, Filler, Polyester, black	1	58	58-2525 10	SCREW, hex, 1/4"-20 x 3/4" stainless steel	4
	58-0722 40		PLUG, Filler, Polypropylene, grey	1	59	58-1950 01	BEARING & PEDESTAL ASSY., with 3/4" S.S. shaft (includes items 45, 48, 49, 50, 51, 57 & 58)	1
	58-0722 60		PLUG, Filler, Ryton, brown	1		58-1950 01H	BEARING & PEDESTAL ASSY., with 3/4" Hastelloy shaft (includes items 45, 48, 49, 50, 51, 57 & 58)	1
24	58-0765 71		O-RING, Filler plug, Buna-N	1		58-1950 01T	BEARING & PEDESTAL ASSY., with 3/4" Titanium shaft (includes items 45, 48, 49, 50, 51, 57 & 58)	1
	58-0765 72		O-RING, Filler plug, EPDM	1	60	58-0686	MOTOR, Hydraulic, Parker	1
	58-0765 73		O-RING, Filler plug, VITON	1		58-0686B	MOTOR, Hydraulic, Cast Iron, Barnes	1
25	58-0718		KEY, steel	1	61	58-0926	GASOLINE ENGINE, CONSULT FACTORY	1
	58-0718 10		KEY, stainless steel	1	62	58-0028	MOTOR, pneumatic	1
	58-0718 30		KEY, Polyester	1	63	58-0016	BASEPLATE KIT, standard duty, call factory for details	1
26	58-0778 11		SHIM, .006", stainless steel	as required		58-0016	BASEPLATE KIT, heavy duty, call factory for details	1
	58-0778 12		SHIM, .015", stainless steel	as required	64	58-0933 72	GASKET, Engine Protection, EPDM, 3.5HP only	1
	58-0778 13		SHIM, .030", stainless steel	as required		58-0935 72	GASKET, Engine Protection, EPDM, INTEK only	1
					65	58-0929	BASE PLATE, for pumps coupled to pneumatic motor	1
					66	58-0002	BASE RUNNER KIT, two steel rails with fasteners	1
					67	58-0009	SUCTION STRAINER, see Bulletin PA-206Q	1
					68	58-0008	ROLL CAGE, w/rubber feet, mounting hardware	1
					69	58-0008	WHEELED CART, for most engine driven pumps	1

NOTE: All specifications, as shown, are subject to change without previous notice.

**servicing
industry
worldwide**

PACER® PUMPS
Div. ASM Industries, Inc.

41 Industrial Circle
Lancaster, PA 17601-5927
Email: sales@pacerpumps.com
717-656-2161
800-233-3861
FAX: 717-656-0477

Distributed By:

www.pacerpumps.com

(Printed in U.S.A.)

PACER ACCESSORIES

PART NUMBER **DESCRIPTION** **TYPES OF 'S' PUMP TO BE USED WITH/ON** **PART NUMBER** **DESCRIPTION** **POLYPROPYLENE QUICK-CONNECT COUPLERS**

P-58-0002	BASE RUNNER KIT - Includes two steel runners (rails) with fasteners	3.5 to 6.5 HP gas engine driven			
P-58-0114	RUBBER FEET KIT - Includes 4 rubber feet/fasteners to be used with 58-0002 base runner kit	3.5 to 8HP gas engine driven	TYPE A	P-58-1405	1 1/2" Male Adapter/Female Threads, NPT
P-58-0003	RUBBER FEET KIT, Includes 4 rubber feet with fasteners	3.5 to 8HP gas engine driven		P-58-1406	2" Male Adapter/Female Threads, NPT
P-58-0014	BUNA-N KIT - Buna-N fitted shaft seal, check valve, allo-rings to rebuild pump.	All pumps		P-58-1505	1 1/2" Male Adapter/Female Threads, BSP
P-58-0005	EPDM KIT, Same as P-58-0014, except EPDM	All pumps		P-58-1506	2" Male Adapter/Female Threads, BSP
P-58-0017	VITON® KIT - Same as P-58-0014, except Viton	All pumps		P-58-1507	3" Male Adapter/Female Threads, BSP
P-58-0015	PROTEK Engine Protection System	All 3.5 to 6.5 HP engines with 3/4" diameter shaft	TYPE B	P-58-1415L	1 1/2" Female Coupler/Male Threads, NPT
P-58-0020	1 1/2" PIPE FITTINGS KIT, NPT - Two faced steel nipples, one polypropylene elbow (for PVC nipples order P-58-0037)	All 1 1/2" pumps		P-58-1416L	2" Female Coupler/Male Threads, NPT
P-58-0021	2" PIPE FITTINGS KIT, NPT - Same as Kit 0020 (for PVC nipples order P-58-0038)	All 2" pumps		P-58-1417L	3" Female Coupler/Male Threads, NPT
P-58-0022	3" PIPE FITTINGS KIT, NPT - Same as Kit 0020 (for PVC nipples order P-58-0039)	All 3" pumps		P-58-1515L	1 1/2" Female Coupler/Male Threads, BSP
P-58-0161	1 1/2" NPT CAMELOT QUICK CONNECT FITTINGS KIT	All 1 1/2" pumps	TYPE C	P-58-1516L	2" Female Coupler/Male Threads, BSP
P-58-0162	2" NPT CAMELOT QUICK CONNECT FITTINGS KIT	All 2" pumps		P-58-1517L	3" Female Coupler/Male Threads, BSP
P-58-0163	3" NPT CAMELOT QUICK CONNECT FITTINGS KIT	All 3" pumps	TYPE D	P-58-1425L	1 1/2" Female Coupler/Hose Shank
P-58-0211	FILL PLUG & DRAIN PLUG KIT	Polyester/EPDM pumps		P-58-1426L	2" Female Coupler/Hose Shank
P-58-702EP-P	REBUILD KIT, for Polyester pumps with 704 impeller contains all internal components	Models starting with SEB2PL, SE2PL, SE11/2 AL and SE2FL		P-58-1427L	3" Female Coupler/Hose Shank
P-58-702EP-U	REBUILD KIT, for Polyester pumps with 706 impeller contains all internal components	Models starting with SEB2UL, SE2UL, SE2CL, SE2L and SE3NL	TYPE E	P-58-1435L	1 1/2" Female Coupler/Female Threads, NPT
P-58-954EP-Y	REBUILD KIT, for Polyester pumps with 974 impeller contains all internal components	Models starting with SEB2YL and SE2YL		P-58-1436L	2" Female Coupler/Female Threads, NPT
P-58-977EP-RS	REBUILD KIT, for Polyester pumps with 975 impeller contains all internal components	Models starting with SEB2RL, SE3SL, SE3LL and SE2JL	TYPE F	P-58-1437L	3" Female Coupler/Female Threads, NPT
P-58-0734	STRAINER, 1 1/2" NPT - For end of suction hose, molded polyethylene	All 1 1/2" pumps		P-58-1535L	1 1/2" Female Coupler/Female Threads, BSP
P-58-0733	STRAINER, 2" NPT - For end of suction hose, molded polyethylene	All 2" pumps		P-58-1536L	2" Female Coupler/Female Threads, BSP
P-58-0757	STRAINER, 3" NPT - For end of suction hose, molded polyethylene	All 3" pumps		P-58-1537L	3" Female Coupler/Female Threads, BSP
P-58-0753-40	ELBOW, 90°, 1 1/2" NPT - Male x Female Street El, molded polypropylene	All 1 1/2" pumps	TYPE G	P-58-1445	1 1/2" Male Adapter/Hose Shank
P-58-0752-40	ELBOW, 90°, 2" NPT - Male x Female Street El, molded polypropylene	All 2" pumps		P-58-1446	2" Male Adapter/Hose Shank
P-58-0756-40	ELBOW, 90°, 3" NPT - Male x Female Street El, molded polypropylene	All 3" pumps		P-58-1447	3" Male Adapter/Hose Shank
P-58-1610-40	ELBOW, 90°, 1 1/2", Male NPT x Hose Shank, polypropylene	All 1 1/2" pumps		P-58-1455	1 1/2" Male Adapter/Male Threads, NPT
P-58-1611-40	ELBOW, 90°, 2", Male NPT x Hose Shank, polypropylene	All 2" pumps		P-58-1456	2" Male Adapter/Male Threads, NPT
P-58-1612-40	ELBOW, 90°, 3", Male NPT x Hose Shank, polypropylene	All 3" pumps		P-58-1457	3" Male Adapter/Male Threads, NPT
P-58-1615-40	HOSE NIPPLE, 1 1/2" MALE NPT x Hose Shank, polypropylene	All 1 1/2" pumps		P-58-1555	1 1/2" Male Adapter/Male Threads, BSP
P-58-1616-40	HOSE NIPPLE, 2" MALE NPT x Hose Shank, polypropylene	All 2" pumps		P-58-1556	2" Male Adapter/Male Threads, BSP
P-58-1617-40	HOSE NIPPLE, 3" MALE NPT x Hose Shank, Polypropylene	All 3" pumps		P-58-1557	3" Male Adapter/Male Threads, BSP

PACER HOSE KITS: 20" SUCTION HOSE, 25" DISCHARGE HOSE, STRAINER AND FITTINGS

P-58-0202	1 1/2" Hose kit with quick-connect hose ends			P-58-1465L	1 1/2" Dust Cap
P-58-0204	2" Hose kit with threaded hose ends			P-58-1466L	2" Dust Cap
P-58-0206	2" Hose kit with quick-connect hose ends			P-58-1467L	3" Dust Cap
P-58-0208	3" Hose kit with quick-connect hose ends			P-58-1475	1 1/2" Dust Plug
				P-58-1476	2" Dust Plug
				P-58-1477	3" Dust Plug

FULL PORT BALL VALVES

P-58-1901 V	1/2"
P-58-1902 V	3/4"
P-58-1903 V	1"
P-58-1904 V	1 1/4"

SEAL REPAIR KIT - includes EPDM shaft seal and all O-rings All pumps

ROLL CAGE for engine driven 'S' pumps Up to 8 HP



Registered Trademarks:
Hastelloy - Haynes International
Viton - DuPont
Ryton - Phillips Chemical

Egloy - Egloy Co.
Kynar - Pennwalt
Halar - Ausimont

An Ounce of Prevention . . .

Flammable solvents are often purchased in bulk and transferred manually or with motor driven pumps. Care must be taken to neutralize static electricity which may rest as a potential in the storage tank, as well as that which may rest in the receiving tank. The potential of such would, of course be greatly

increased if the liquid were allowed to splash around during movement of the container. Therefore both containers must be satisfactorily grounded, and then each of the containers must be bonded, that is connecting the ground wire from tank to tank so that the potential static electricity is now equalized.

SPARKS FROM OPEN MOTOR CAUSE EXPLOSION

“User of pump is burned while transferring explosive liquids. Accident was caused by the use of an open motor... Explosion resulted and the employee was burned over many parts of his body.”

In addition to the proper use of bonding and grounding cables, when motorized pumps are used to transfer flammables and combustibles those of the explosion proof or air driven type should be used. Electric or air motors are often wired and/or enclosed in such a way that no sparks can be emitted from the motor casing - otherwise sparks from the motor could cause the flammable liquid to flash or explode.

SLASHING OF ACID CAUSES BURNS

“Operator working with aggressive acids receives skin burns when pump, which was energized, created pressure in a pressure vessel not closed properly, therefore allowing liquid to escape and splashing the operator.”

Operator should have checked the instruction manual and followed procedures as set forth by the manufacturer to ensure that the cover of the pressure vessel was securely tightened. Operator could also have prevented bodily injury if he was protected with adequate clothing, which is fabricated to resist such liquids.

Injuries due to splashing of aggressive liquids or explosion of flammables can be avoided by wearing proper clothing, which may include coveralls, aprons, shoes, goggles, gloves, face mask, respirator and hat. Each of the above operators could have avoided some bodily harm by wearing outer garments for protection from skin burns.

LIMITED 1 YEAR WARRANTY

Pacer Pumps warrants its products to be free from defects of material and workmanship for a period of one year (12 months) of service if the one year of service falls within 24 months from date of manufacture. The company warrants that its products, at the time of shipment, will be free of defects of material and workmanship for normal use and service. This warranty will not apply or be extended to products subjected to misuse, neglect, accident, or improper installation, or to maintenance of products which have been altered or repaired by anyone except Pacer Pumps or its authorized representatives. The Buyer, or any person receiving such a product during the duration of the warranty shall contact his Pacer Pumps dealer as soon as any defect occurs. Contact Pacer Pumps for the name and address of your nearest dealer.

Certain components, such as mechanical seals, ceramic liners, impellers, impeller magnet assemblies, pistons, hose, diaphragms, etc. may be subject to wear, and therefore wear should not be misconstrued as to the existence of a defect and as such would not be included in a warranty claim, nor should it be implied that items such as this will last a year without occasional, or even frequent replacement depending upon the severity of the application.

Pacer Pumps' sole obligation under the foregoing warranty shall be limited to: (at its option) repair and replacement (and reship to the Buyer with transportation charges collect to any place in the U.S.) of defective goods provided that if the company

is unable to correct a defective component part or product, the Buyer shall be entitled to elect a credit at the original Buyer's purchase price. To return a DEFECTIVE PUMP, to return any parts for credit, or to obtain service information, contact the Service Department. After receiving permission to return merchandise, the Buyer is authorized to return the product to Pacer Pumps, freight prepaid. If the company determines that the warranty has not been breached, product will be repaired or replaced free of charge.

The company will not be responsible for any damages or losses, direct or indirect, arising from any cause whatsoever, nor for damage to equipment caused by outside influences including improper installation or modification, improper voltage supply, lightning, corrosive liquids, abrasive liquids, or careless handling; nor for labor, transportation or other damages incurred in the replacement or repair to defective parts. In these cases, repair will be subject to reconditioning charges in effect at the time.

Purchased merchandise, either as a complete product for resale or components used in conjunction with Pacer Pumps manufactured products, carries the warranty of the respective manufacturer of such product or components.

servicing
industry
worldwide

PACER® PUMPS

Div. ASM Industries, Inc.
41 Industrial Circle
Lancaster, PA 17601-5927
Email: sales@pacerpumps.com
www.pacerpumps.com

717-656-2161
800-233-3861
FAX: 717-656-0477

Part Number 58-1745 01

NOTE: All specifications, as show, are subject to change without previous notice.