



Floor Mounted Drill Press

Owner's Manual



! **WARNING:** Read carefully and understand all ASSEMBLY AND OPERATION INSTRUCTIONS before operating. Failure to follow the safety rules and other basic safety precautions may result in serious personal injury.

Items #49383

Thank you very much for choosing a Klutch product!

For future reference, please complete the owner's record below:

Serial Number/Lot Date Code: _____

Purchase Date: _____

Save the receipt, warranty, and this manual. It is important that you read the entire manual to become familiar with this product before you begin using it.

These 13", 14", and 17" floor mounted drill presses are designed for certain applications only. Northern Tool and Equipment is not responsible for issues arising from modification or improper use of this product such as an application for which it was not designed. We strongly recommend that this product not be modified and/or used for any application other than that for which it was designed.

For technical questions, please call **1-800-222-5381**.

Table of Contents

Intended Use.....	4
Technical Specifications	4
Important Safety Considerations	5
Specific Operation Warnings	7
Grounding	9
Extension Cords.....	10
Assembly	11
Before Each Use.....	14
Operating Instructions.....	16
After Each Use.....	19
Maintenance	20
Parts Diagram	21
Parts List	22
Troubleshooting.....	24
Replacement Parts	24
Limited Warranty	25

Intended Use

These drill presses include multiple or variable speeds for drilling holes on cast iron, steel, aluminum, wood, etc. The presses have been designed for indoor use and must be used only in dry conditions.

Technical Specifications

Property	Specification
Voltage / Frequency:	120V / 60Hz
Motor Power	3/4 HP
Chuck	5/8"
Spindle Travel	3-1/4"
Spindle Taper	MT2
Speed Change	16 speeds
Speed	260-3410 r/min
Dist. Spindle to Column	6-3/8"
Table Size	D 11 3/8"
Base Size	18-1/8" X 11-1/32"
Column	2-27/32"
Total Height	62-3/16"

Important Safety Considerations

⚠ WARNING

- Read and understand all instructions. Failure to follow all instructions may result in serious injury.
- The warnings, cautions, and instructions in this manual cannot cover all possible conditions or situations that could occur. Exercise common sense and caution when using the drill press. Always be aware of the environment and ensure that the drill press is used in a safe and responsible manner.
- DO NOT modify the drill press in any way. Unauthorized modification may impair the function and/or safety and could affect the life of the drill press. There are specific applications for which the product was designed.
- DO NOT allow persons to operate or assemble the drill press until they have read this manual and have developed a thorough understanding of how it works.
- Use the right tool for the job. DO NOT attempt to force small equipment to do the work of larger industrial equipment. There are certain applications for which this equipment was designed. It will do the job better and more safely at the capacity for which it was intended. DO NOT use this equipment for a purpose for which it was not intended.
- Industrial or commercial applications must follow OSHA requirements.
- This product may contain chemicals known to the State of California to cause cancer, birth defects or other reproductive harm.
- Some dust created by power sanding, sawing, grinding, drilling, and other construction activities contains chemicals known to the State of California to cause cancer, birth defects, or other reproductive harm. Some examples of these chemicals are:
 - lead from lead-based paints,
 - crystalline silica from bricks and cement and other masonry products, and
 - arsenic and chromium from chemically-treated lumber.
- Your risk from these exposures varies, depending on how often you do this type of work. To reduce your exposure to these chemicals: work in a well-ventilated area, and work with approved safety equipment, such as dust masks that are specially designed to filter out microscopic particles.
- Handling power cords on corded products may expose you to lead, a chemical known to the State of California to cause cancer and birth defects or other reproductive harm. Wash your hands after handling.

⚠ WARNING

WORK AREA SAFETY

- Inspect the work area before each use. Keep work area clean, dry, free of clutter, and well lit. Cluttered, wet, or dark work areas can result in injury. Using the tool in confined work areas may put you dangerously close to other cutting tools and rotating parts.
- Do not use the drill press where there is a risk of causing a fire or an explosion; e.g., in the presence of flammable liquids, gases, or dust. The drill press can create sparks, which may ignite the dust or fumes.
- Keep children and bystanders away from the work area while operating the drill press. Do not allow children to operate the drill press.

PERSONAL SAFETY

- Stay alert, watch what you are doing, and use common sense when operating the drill press. Do not use the drill press while you are tired or under the influence of drugs, alcohol, or medication. A moment of inattention while operating the drill press may result in serious personal injury.
- Dress properly. Do not wear loose clothing, dangling objects, or jewelry. Keep your hair, clothing and gloves away from moving parts. Loose clothes, jewelry, or long hair can get caught.
- Use ANSI Z87.1-compliant safety goggles or when needed, a face shield. Use a dust mask in dusty work conditions. Also use non-skid safety shoes, hardhat, gloves, dust collection systems, and hearing protection when appropriate. This applies to all persons in the work area.
- Do not overreach. Keep proper footing and balance at all times.
- Remove adjusting keys or wrenches before turning on the drill press. A wrench or key that is left attached to a rotating part of the drill press may cause personal injury.
- Secure the work with clamps or a vise instead of your hand. This safety precaution allows for proper drill press operation using both hands.

▲ WARNING

ELECTRICAL SAFETY

- Grounded tools must be plugged into an outlet properly installed and grounded in accordance with all codes and ordinances. Never remove the grounding prong or modify the plug in any way. Do not use any adapter plugs. Check with a qualified electrician if you are in doubt as to whether the outlet is properly grounded. If the tools should electrically malfunction or break down, grounding provides a low resistance path to carry electricity away from the user.
- Double insulated tools are equipped with a polarized plug (one blade is wider than the other). This plug will fit in a polarized outlet only one way. If the plug does not fit fully in the outlet, reverse the plug. If it still does not fit, contact a qualified electrician to install a polarized outlet. Do not change the plug in any way. Double insulation eliminates the need for the three wire grounded power cord and grounded power supply system.
- Do not allow the product to come into contact with an electrical source. The tool is not insulated and contact will cause electrical shock.
- Avoid body contact with grounded surfaces such as pipes, radiators, ranges, and refrigerators. There is an increased risk of electric shock if your body is grounded.
- Do not expose power tools to rain or wet conditions. Water entering a power tool will increase the risk of electric shock.
- Do not abuse the power cord. Never use the power cord to carry the tools or pull the plug from an outlet. Keep the power cord away from heat, oil, sharp edges, or moving parts. Replace damaged power cords immediately. Damaged power cords increase the risk of electric shock.
- When operating a power tool outside, use an outdoor extension cords marked "W-A" or "W". These extension cords are rated for outdoor use, and reduce the risk of electric shock.

⚠ CAUTION

DRILL PRESS USE AND CARE

- Do not force the tool. Tools do a better and safer job when used in the manner for which they are designed. Plan your work, and use the correct tool for the job.
- Check for damaged parts before each use. Carefully check that the tool will operate properly and perform its intended function. Replace damaged or worn parts immediately. Never operate the tool with a damaged part.
- Do not use a tool with a malfunctioning switch. Any power tool that cannot be controlled with the power switch is dangerous and must be repaired by an authorized service representative before using.
- Disconnect the power/air supply from the product and place the switch in the locked or off position before making any adjustments, changing accessories, or storing the tool. Such preventive safety measures reduce the risk of starting the tool accidentally.
- Store the tool when it is not in use. Store it in a dry, secure place out of the reach of children. Inspect the tool for good working condition prior to storage and before re-use.
- Use only accessories that are recommended by the manufacturer for use with your tool. Accessories that may be suitable for one tool may create a risk of injury when used with another tool. Never use an accessory that has a lower operating speed or operating pressure than the tool itself.
- Keep guards in place and in working order. Never operate the product without the guards in place.
- Do not leave the tool running unattended.

Specific Operation Warnings

⚠ WARNING

GENERAL SAFETY INSTRUCTIONS

To avoid mistakes that could cause serious injury, do not plug the Drill Press in until you have read and understood the following:

- **USE PROPER EXTENSION CORDS.** Make sure your extension cord is in good condition. When using an extension cord, be sure to use one heavy enough to carry the current your product will draw. An undersized cord will result in a drop in line voltage and in loss of power that will cause the tool to overheat.
- **ALWAYS WEAR EYE PROTECTION.** Any Drill Press can throw foreign objects into the eyes that could cause permanent eye damage. ALWAYS wear ANIS Z87.1 compliant safety Goggles (not glasses). Everyday eyeglasses have only impact-resistance lenses. They ARE NOT safety glasses. USE a face or dust mask along with safety goggles if drilling operation is dusty. USE ear protectors, especially during extended periods of operation.
- **USE ONLY RECOMMENDED ACCESSORIES.** See the Accessories section in this manual for recommended accessories. The use of improper accessories may cause serious injury.
- **NEVER TIP THE DRILL PRESS.** Serious injury could occur if the tool is tipped while running or if the cutting tool is unintentionally contacted.
- **CHECK FOR DAMAGED PARTS BEFORE EACH USE.** Before further use of the tool, a guard or other part that is damaged should be carefully checked to determine that it will operate properly and perform its intended function – check for alignment of moving parts, binding of moving parts,

breakage of parts, mounting, and any other conditions that may affect its operation. A guard or other part that is damaged should be properly repaired or replaced.

- ALWAYS operate the Drill Press in a well-ventilated area and provide for proper dust removal. Use dust collection systems whenever possible. Dust generated from certain materials can be hazardous to your health.
- THIS DRILL PRESS is intended for use in dry conditions, indoor use only.
- DO NOT try to drill material too small to be securely held.
- ALWAYS keep hands out of the path of a drill bit. Avoid awkward hand positions where a sudden slip could cause your hand to move into the drill bit. DO NOT install or use any drill bit that exceeds 175mm in length or extends 150mm below the chuck jaws. They can suddenly bend outward or break.
- DO NOT USE wire wheels, router bits, shaper cutters, circle (fly) cutters, or rotary planers on this drill press.
- WHEN cutting a large piece of material, make sure it is fully supported at the table height.
- DO NOT perform any operation freehand. ALWAYS hold the workpiece firmly against the table so it will not rock or twist. Use clamps or a vise for unstable workpieces.
- CLAMP THE WORKPIECE OR BRACE IT against the left side of the column to prevent rotation. If it is too short or the table is tilted, clamp it solidly to the table.
- IF THE WORKPIECE overhangs the table such that it will fall or tip if not held, clamp it to the table or provide auxiliary support.
- MAKE SURE there are no nails or foreign objects in the part of the workpiece to be drilled.
- MAKE SURE all clamps and locks are firmly tightened and securely lock the head and table support to the column and the table to the table support before operating the drill press.
- NEVER turn your drill press ON before clearing the table of all objects (tools, scraps, etc.).
- BEFORE STARTING the operation, jog the motor switch to make sure the drill bit does not wobble or vibrate.
- LET THE SPINDLE REACH FULL SPEED before starting to drill. If your drill press makes an unfamiliar noise or if it vibrates excessively, stop immediately, turn the drill press OFF and unplug. Do not restart the unit until the problem is corrected.
- DO NOT perform layout assembly or set up work on the table while the drill press is in operation.
- USE THE RECOMMENDED SPEED for any drill press accessory and for different workpiece material.
- WHEN DRILLING large diameter holes, clamp the workpiece firmly to the table. Otherwise, the bit may grab and spin the workpiece at high speeds. DO NOT USE fly cutters or multiple-part hold cutters, as they can come apart or become unbalanced in use.
- MAKE SURE the spindle has come to a complete stop before touching the workpiece.
- To avoid electrical hazards, fire hazards, or damage to the tool, use proper circuit protection. Use a separate electrical circuit for your machine. To avoid shock or fire, if power cord is worn or cut, or damaged in any way, have it replaced immediately.

Grounding

⚠ WARNING

- This machine must be grounded while in use to protect the operator from electrical shock. This drill press is equipped with an electric cord that has an equipment-grounding conductor and a grounding plug. The plug **MUST** be plugged into a matching receptacle that is properly installed and grounded in accordance with ALL local codes and ordinances.
- **DO NOT MODIFY THE PLUG PROVIDED.** If it will not fit the receptacle, have the proper receptacle installed by a qualified electrician.
- **CHECK** with a qualified electrician or service person if you do not completely understand the grounding instructions, or if you are not sure the tool is properly grounded.

Grounded Tools: Tools with 3-Prong Plugs

Tools marked with **Grounding Required** have a 3-wire cord and 3-prong grounding plug. The plug must be connected to a properly grounded outlet. If the tool should electrically malfunction or break down, grounding provides a low resistance path to carry electricity away from the user, reducing the risk of electric shock. (See Figure A.)

The grounding prong in the plug is connected through the green wire inside the cord to the grounding system in the tool. The green wire in the cord must be the only wire connected to the tool's grounding system and must never be attached to an electrically live terminal.

Your tool must be plugged into an appropriate outlet, properly installed and grounded in accordance with all codes and ordinances. The plug and outlet should look like those in the following illustration.

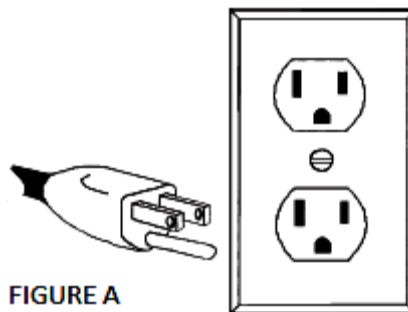

FIGURE A

Double Insulated Tools: Tools with Two-Prong Plugs

Tools marked **Double Insulated** do not require grounding. They have a special double insulation system which satisfies OSHA requirements and complies with the applicable standards of Underwriters Laboratories, Inc., the Canadian Standard Association, and the National Electrical Code. (See Figure B.)

Double insulated tools may be used in either of the 120 volt outlets shown in the following illustration.

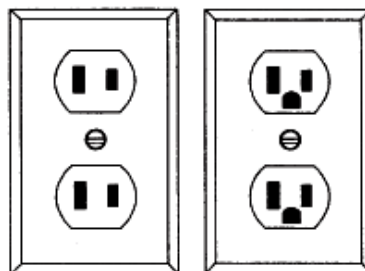

FIGURE B

Extension Cords

⚠ WARNING

- **USE A PROPER EXTENSION CORD.** Make sure your extension cord is in good condition. When using an extension cord, be sure to use one heavy enough to carry the current your product will draw. An undersized cord will cause a drop in line voltage, resulting in loss of power and cause overheating.
- Be sure your extension cord is properly wired and in good condition. Always replace a damaged extension cord or have it repaired by a qualified person before using it. Protect your extension cords from sharp objects, excessive heat and damp or wet areas.

- Grounded tools require a 3-wire extension cord. Double Insulated tools can use either a 2- or 3-wire extension cord.
- As the distance from the supply outlet increases, you must use a heavier gauge extension cord. Using extension cords with inadequately sized wire causes a serious drop in voltage, resulting in loss of power and possible tool damage.
- The smaller the gauge number of the wire, the greater the capacity of the cord. For example, a 14-gauge cord can carry a higher current than a 16-gauge cord. Minimum extension cord wire size is shown in the following table:

Minimum Wire Size Of Extension Cords				
Nameplate AMPS	Cord Length			
	25'	50'	100'	150'
0-6	18 AWG	16 AWG	16 AWG	14 AWG
6-10	18 AWG	16 AWG	14 AWG	12 AWG
10-12	16 AWG	16 AWG	14 AWG	12 AWG
12-16	14 AWG	12 AWG	NOT RECOMMENDED	

- When using more than one extension cord to make up the total length, make sure each cord contains at least the minimum wire size required.
- If you are using one extension cord for more than one tool, add the nameplate amperes and use the sum to determine the required minimum cord size.
- If you are using an extension cord outdoors, make sure it is marked with the suffix **W-A** (**W** in Canada) to indicate it is acceptable for outdoor use.
- Make sure your extension cord is properly wired and in good electrical condition. Always replace a damaged extension cord or have it repaired by a qualified electrician before using it.
- Protect your extension cords from sharp objects, excessive heat, and damp or wet areas.

Assembly

⚠ WARNING

For your own safety, do not try to plug in the drill press until it is completely assembled and installed according to the instructions and until you have read and understood this instruction manual.

⚠ WARNING

- To avoid injury from unexpected starting, do not plug the power cord into a power source receptacle during unpacking and assembly. This cord must remain unplugged whenever you are assembling or adjusting the machine.
- If any part is missing or damaged, do not plug the machine in until the missing or damaged part is replaced, and assembly is complete.
- To protect the machine from moisture, a protective coating has been applied to the machined surfaces. Remove this coating with a soft cloth moistened with kerosene.

1. Unpack the shipping carton and check the contents to verify all the parts listed below are present

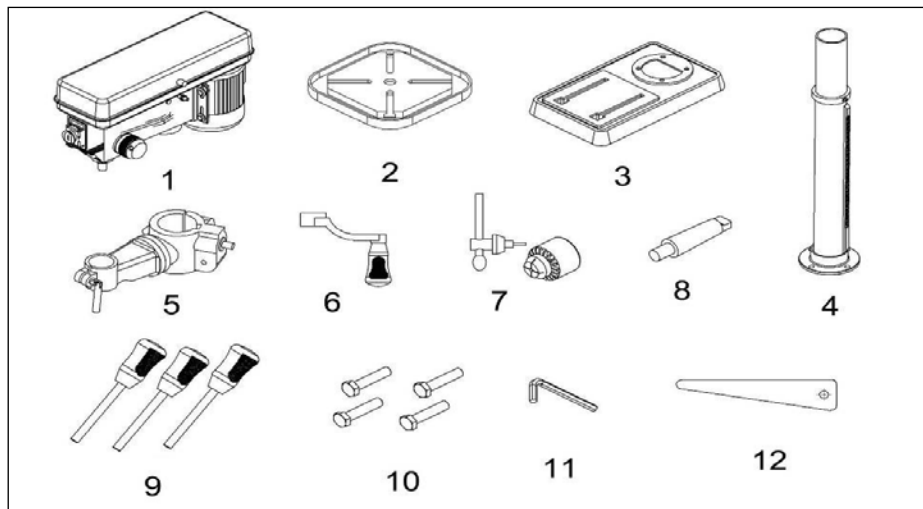

1. Head assembly (1pc)	7. Chuck and key (1pc)
2. Table (1pc)	8. Arbor (1pc)
3. Base (1pc)	9. Feed handle (3pcs)
4. Column assembly (1pc)	10. Bolt (4pcs)
5. Table support assembly (1pc)	11. Hex wrench (2pcs)
6. Crank handle (1pc)	12. Wedge (1pc)

2. Install the column support to the base

- a. Position the base on the floor or a workbench.
- b. Place the column on the base, aligning the holes in the column support with the holes in the base.
- c. Locate the four long hex bolts from the loose parts bag.
- d. Place a bolt in each hole through the column support and the base. Tighten with an adjustable wrench. See Fig. 1

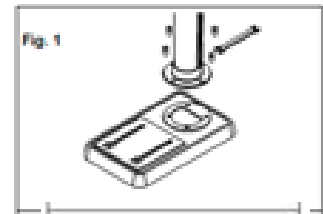

3. Install the table and rack

- a. Take the retaining ring off and table bracket.
- b. Install the table support and bracket. See Fig. 2 and the parts list.
- c. Reinstall the retaining ring and secure it firmly. See Fig. 3

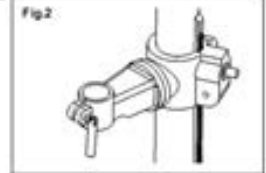

4. Install the crank handle and table. See Figs 4 and 5 and the parts list.

- a. Fix the crank handle with the attached screw
- b. Tighten the clamp bolt to lock the table bracket.
- c. Place the table onto table support. See Fig. 6

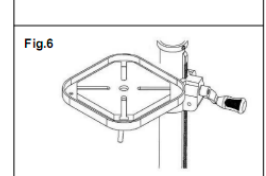
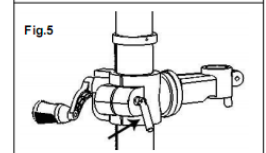
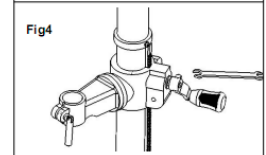

5. Installing the head assembly

- a. Carefully lift the head assembly above the column and slide it onto the column. Make sure the head slides down over the column as far as possible. Align the head with the base.
- b. Using the hex wrench, tighten the head lock set screws. See Fig. 7

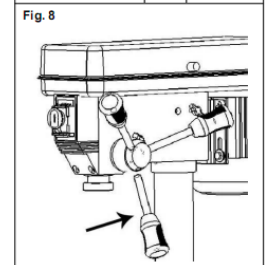
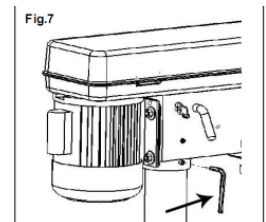

6. Installing the feed handles

- a. Locate the three feed handles in the loose parts bag.
- b. Screw the feed handles into the threaded holes in the hub and tighten them. See Fig. 8

7. Before any assembly of the chuck and arbor to the drill press head, clean all mating surfaces with a non-petroleum based product; such as alcohol or lacquer thinner. Any oil or grease used in the packing of these parts must be removed; otherwise the chuck may come loose during operation.

8. Install the chuck

- a. Open the jaws of the chuck by rotating the chuck sleeve clockwise. To prevent damage, make sure the jaws are completely retracted into the chuck.
- b. Push the chuck onto the spindle.

NOTE: Clean the spindle taper with a non-alcohol based cleaner before inserting it into the chuck.

- c. Using a wood mallet, firmly tap the chuck upward into position on the spindle shaft. See Fig. 9

9. Install the knob and screw of upper pulley cover. See Fig.10

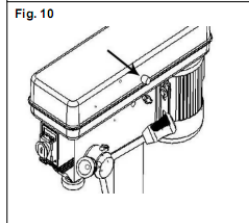
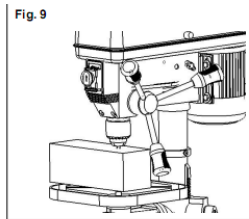

Before Each Use

⚠ WARNING

To avoid injury from accidental starting, always turn the switch OFF and unplug the drill press before installing or removing any accessory or attachment or making any adjustment.

Make the following adjustments before each use of the drill press.

1. Table Adjustment

A. Height adjustment

To adjust the table up or down:

Loosen the locking handle then adjust the table to your desired height using the table bracket crank handle. See Fig. 11

B. Tilting adjustment:

Loosen the locking handle then tilt the table to the desired angle and retighten the handle. See Fig. 12

C. Swing adjustment

Loosen the locking handle then rotate the table to a desired position and retighten the handle. See Fig. 13

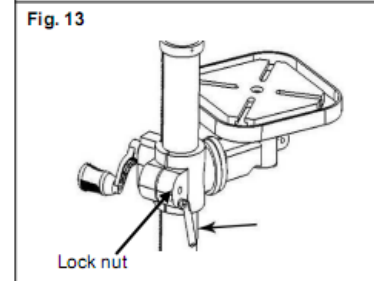
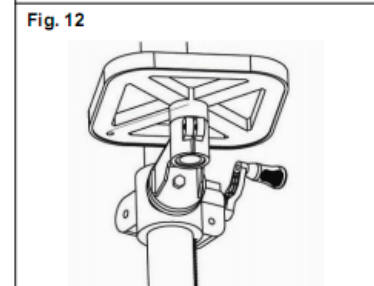
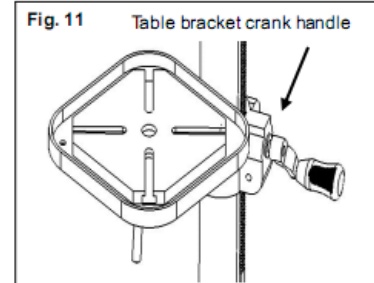

2. Feed Depth Adjustment

2.1 Loosen the locking screw; rotate scale so desired depth is indicated on scale next to the pointer. Tighten locking screw. Use this feature to drill more than one hole to same depth.

2.2 Spindle can be locked in either fully or partially down position. Loosen locking screw. Lower chuck to desired depth, rotate scale fully clockwise and tighten locking screw. Use this feature to set up and align work.

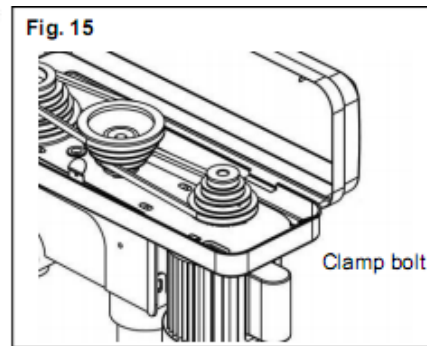

3. SPEED ADJUSTING

The spindle speeds shown in the speed label. To change the speed, loose the belt tension lock knob , pull the motor mounting plate to the front end then change the belt location. To tighten the belt, push the motor mounting plate to the rear end and lock the belt tension lock knob. See Fig.15

4. Quill Spring Adjustment

The quill return spring may need adjustment if the tension causes the quill to return too rapidly or too slowly. See Fig. 16

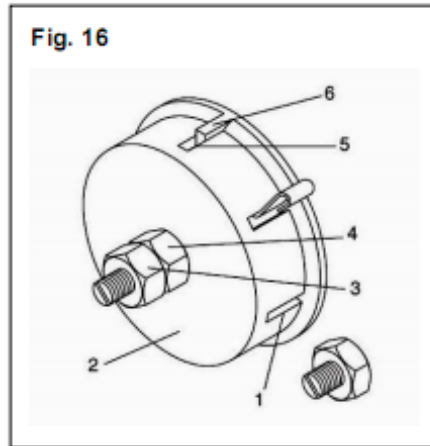

- a. Lower the table for additional clearance.
 - b. Place a screwdriver in the lower front notch (1) of the spring cap (2). Hold it in place while loosening and removing only the outer jam nut (3).
 - c. e
- CAUTION:** DO NOT REMOVE THIS INNER NUT, because the spring will forcibly unwind.
- d. Carefully turn the spring cap (2) counterclockwise with the screwdriver, engaging the next notch.
 - e. Lower the quill to the lowest position by rotating the feed handle in a counterclockwise direction while holding the spring cap (2) in position.
 - f. If the quill moves up and down as easily as you desire, tighten the inner nut (4) with the adjustable wrench. If too loose, repeat steps b through d to tighten. If too tight, reverse steps c and d. **DO NOT OVERTIGHTEN;** this will restrict quill movement.
 - g. Replace the jam nut (3) and tighten against the inner nut (4) to prevent the inner nut from loosening. Fig. 17

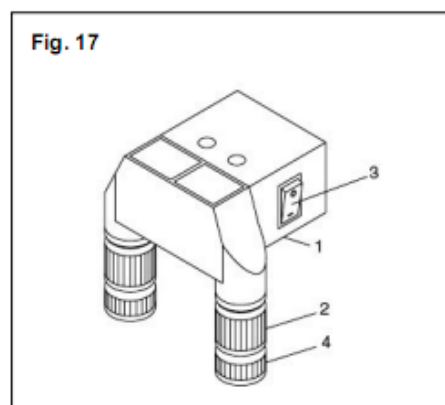

Operating Instructions

⚠ WARNING

To avoid injury from accidental starting, always turn the switch OFF and unplug the drill press before installing or removing any accessory or attachment or making any adjustment.

Always wear safety goggles when operating the drill.

⚠ WARNING

- Use only accessories designed for this machine to avoid injury from thrown broken parts.
- Follow instructions that accompany accessories. Do not use any accessory unless you have completely read the instruction or operator's manual for that accessory.

1. Installing A Drill Bit

- a. With the switch "OFF", open the chuck jaws (1) using the chuck key (2). Turn the chuck key counterclockwise to open the chuck jaws (1).
- b. Insert the drill bit (3) into the chuck far enough to obtain maximum gripping by the jaws, but not far enough to touch the spiral grooves (flutes) of the drill bit when the jaws are tightened.
- c. Make sure that the drill is centered in the chuck.
- d. Turn the chuck key clockwise to tighten the jaws.
- e. When fully tightened, remove the chuck key.

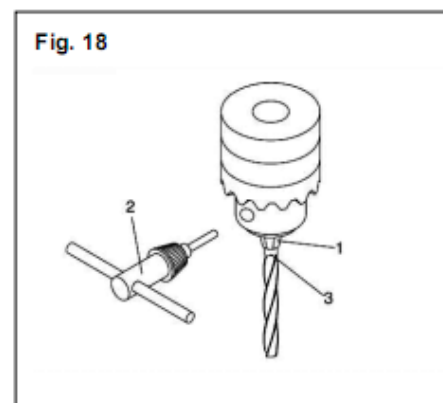

⚠ WARNING

Always recheck and remove the chuck key before turning the power ON to avoid injury or accident by the chuck key ejecting forcibly from the chuck.

Fig. 19

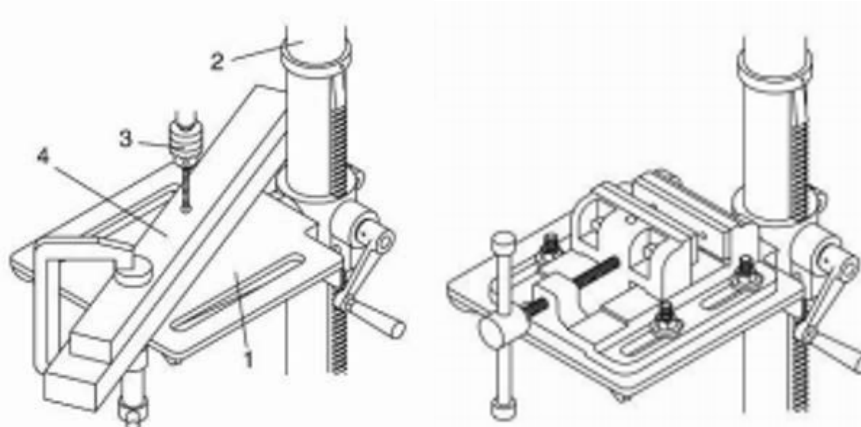

2. Positioning the Workpiece

To prevent the workpiece or backing piece from being torn from your hands while drilling, you MUST position it against the LEFT side of the column. Failure to do this could result in personal injury. See Fig.19

3. Using a Vise

Use a drill press vise to hold a small workpiece that cannot be clamped to the table. The vise must be clamped to the table.

⚠ WARNING

A drill press vise, if used, **MUST** be clamped or bolted to the table to avoid injury from a spinning workpiece or damage to the vise or bit parts

4. Correct Drill Speeds

⚠ WARNING

To avoid injury from accidental starting, always turn the switch OFF and unplug the drill press before adjusting speeds.

Use the recommended speed for the drill bit and workpiece. The drill bits that can be used are shown in following figure:

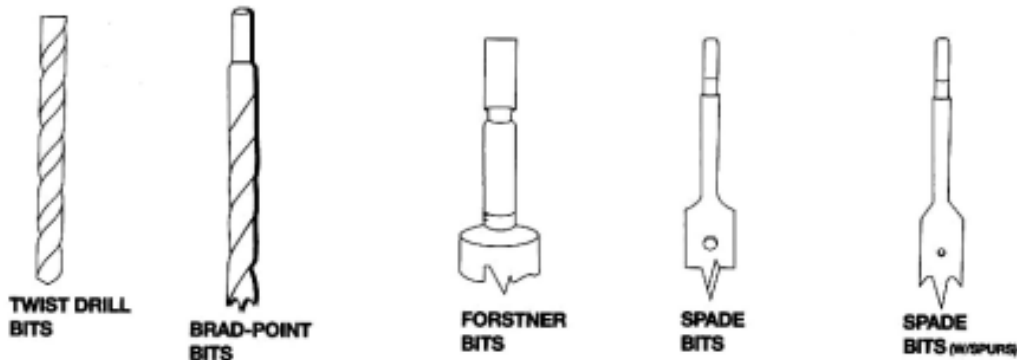

Recommended Operating Speeds (in RPMS)

	Material					
	SOFTWOOD	HARDWOOD	ACRYLIC	BRASS	ALUMINUM	STEEL
TWIST DRILL BITS						
1/16-3/16" (3-5mm)	3000	3000	2500	3000	3000	3000
1/4-3/8" (6-10mm)	3000	1500	2000	1200	2500	1000
7/16-5/8" (11-16mm)	1500	750	1500	750	1500	600
11/16-1" (11-25mm)	750	500	NR	400	1000	250
BRAD-POINT BITS						
1/8"	1800	1200	1500	NR	NR	NR
1/4"	1800	1000	1500	NR	NR	NR
3/8"	1800	750	1500	NR	NR	NR
1/2"	1800	750	1000	NR	NR	NR
5/8"	1800	500	750	NR	NR	NR
3/4"	1400	250	750	NR	NR	NR
7/8"	1200	250	500	NR	NR	NR
1"	1000	250	200	NR	NR	NR
FORSTNER BITS						
1/4-3/8"	2400	700	250	NR	NR	NR
1/2-5/8"	2400	500	250	NR	NR	NR
3/4-1"	1500	500	250	NR	NR	NR
1 1/8-1 1/4"	1000	250	250	NR	NR	NR
1 3/8-2"	500	250	NR	NR	NR	NR
SPADE BITS						

1/4-1/2"	2000	1500	NR	NR	NR	NR
5/8-1 1/2"	1750	1500	NR	NR	NR	NR
1 1/8-1 1/2"	1500	1000	NR	NR	NR	NR
SPADE BITS WITH SPURS						
3/8-1 NR	2000	1800	500	NR	NR	NR

NR-Not Recommended

After Each Use

After each use,

- Disconnect the power cord
- Clear up the scrap iron
- Clean the surface
- Add anti-rust oil onto the metal surface of workbench, baseboard, column and main spindle quill

Maintenance

⚠ WARNING

- TO AVOID INJURY from accidental starting, always turn the power switch OFF and unplug the drill press before installing or removing any accessory or attachment or making any adjustment.
- MAINTAIN TOOLS WITH CARE. Keep tools sharp and clean for best and safest performance. Follow instructions for lubricating and changing accessories.

Maintain your tool. It is recommended that the general condition of any tool be examined before it is used. Keep your tool in good repair by adopting a program of conscientious repair and maintenance in accordance with the recommended procedures found in this manual. Keep all cutting tools sharp and clean. Properly maintained cutting tools with sharp cutting edges are less likely to bind and are easier to control. Keep handles dry, clean, and free from oil and grease.

Daily Maintenance

Before each use:

Check and adjust the tightness of the belt.

Ensure the protective guard is assembled well.

Check that the power cord is undamaged.

Run the machine

After each use:

Disconnect the power cord.

Clear the scrap iron.

Clean the surface.

Add anti-rust oil onto the metal surface of workbench, baseboard, column and main spindle quill.

Periodic Maintenance

After 100 hours:

Check the tightness of the spindle reset spring.

Lubricate the lifting gear rack of workbench with lubricating grease.

Check that all clamp handles are in good condition.

After 6 months:

Check and ensure the bearing is in good condition.

Check whether the precision of the drilling machine meets the needs of the work.

Check that all electrical parts are in good condition.

Parts Diagram

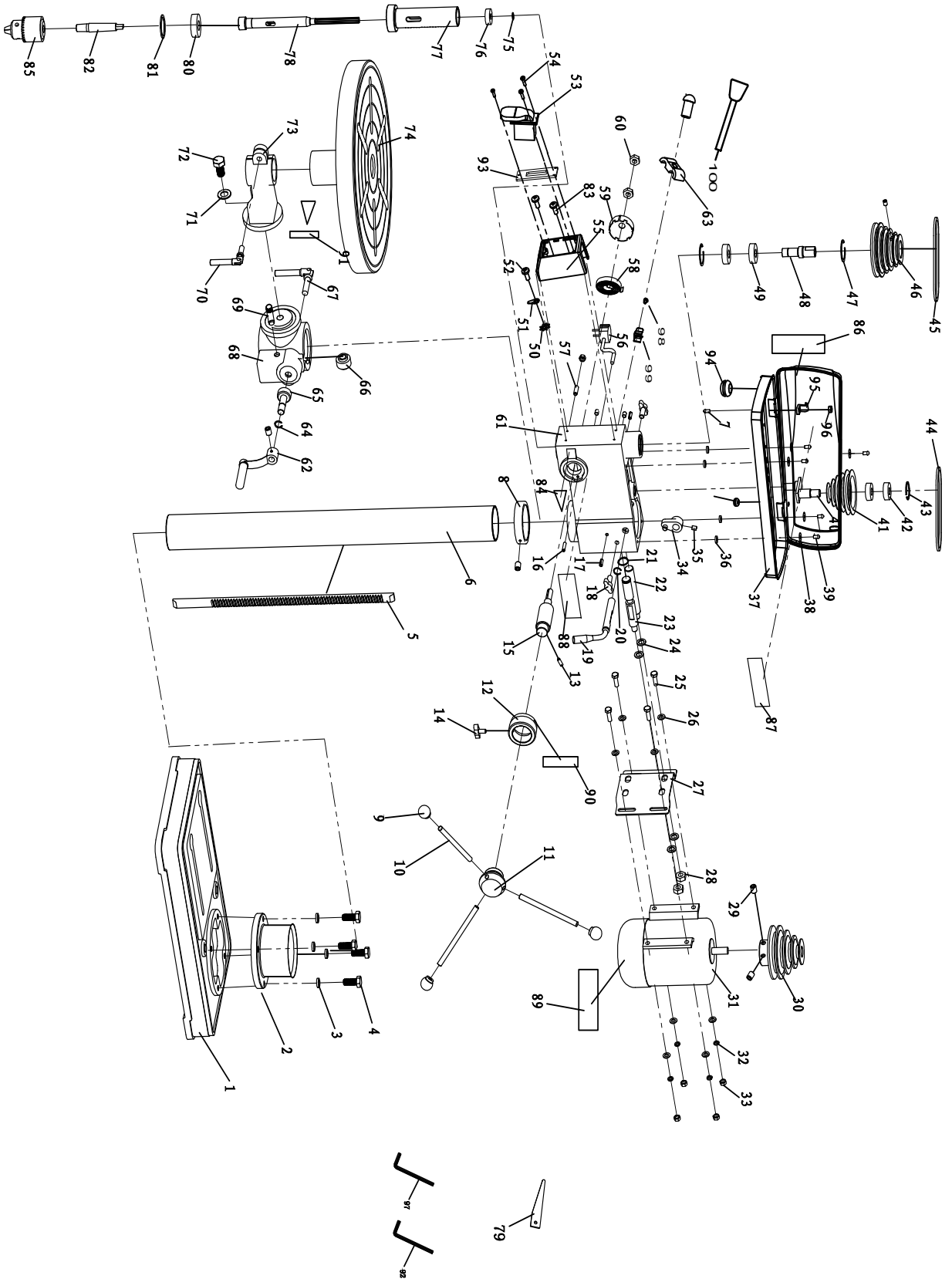

Parts List

No.	Description	Q'ty	No.	Description	Q'ty
1	BASE	1	51	GROUNDING PARTS 5	1
2	COLUMN FLANGE	1	52	CROSS RECESS HEAD SCREW M5x6	1
3	SPRING WASHER 10	4	53	SWITCH	1
4	OUTSIDE HEX. BOLT M10x25	4	54	CROSS RECESS HEAD TAPPING SCREW M3.2x10	1
5	RACK	1	55	SWITCH BOX	2
6	COLUMN	1	56	PLUG WITH CABLE	1
7	CROSS RECESS PAN HD SCREW M5x12	3	57	A WORD HEAD SCREW M8X25	1
8	COLLAR RACK	1	58	SPRING	1
9	HANDLE TIP	3	59	SPRING COVER	1
10	HANDLE	3	60	THIN NUT M12	2
11	HANDLE SEAT	1	61	HOUSING	2
12	DIAL SCALE	1	62	CRANK	1
13	ROLL PIN 5X16	1	63	CORD CLAMP	1
14	WING KNOB M8X18	1	64	CIRCLIP FOR BEARING 14	1
15	GEAR SHAFT	1	65	WORM	1
16	THREAD PIN WITH SLOT M6X20	1	66	WORM GEAR	1
17	ROLL PIN 6X18	2	67	LOCKING HANDLE M12X45	1
18	HANDLE KNOB M10X25	2	68	TABLE SUPPORT	1
19	HANDLE BELT TENSION	1	69	WORM PIN	1
20	CIRCLIP FOR BEARING 15	1	70	LOCKING HANDLE M10X32	1
21	CIRCLIP FOR BEARING 19	1	71	SPRING WASHER 16	1
22	SLIP SHAFT	1	72	OUTSIDE HEX BOLT M16x30	1
23	ADJUSTING SHAFT	1	73	TABLE ARM	1
24	FLAT WASHER 12	4	74	WORKING TABLE	1
25	OUTSIDE HEX. BOLT M8x25	4	75	CIRCLIP FOR BEARING 12	1
26	FLAT WASHER 8	8	76	BEARING 6204	1
27	MOTOR CONNECTION PLATE	1	77	SPINDLE SOCKET	1
28	NUT M12	2	78	MAIN SPINDLE	1
29	HEX. SOC SET SCREW M6x10	4	79	THICK BRAKE IRON	1
30	MOTOR PULLEY	1	80	BEARING 6201	1
31	MOTOR	1	81	WASHER Ø47	1
32	SPRING WASHER 8	4	82	TAPER SPINDLE	1
33	NUT M8	5	83	CROSS RECESSED PAN HEAD SCREW M5x12	5
34	CAM ASSEMBLY	1	84	INDICATOR	1
35	OUTSIDE HEX BOLT M8X12	1	85	CHUCK	1
36	DAMPING WASHER	4	86	PULLEY COVER LABEL	1
37	PULLEY COVER	1	87	SPEED LABEL	1
38	FLAT WASHER 6	5	88	WARNING LABEL	1
39	CROSS RECESSED PAN HEAD SCREW M6x12	6	89	MOTOR LABEL	1
40	ECCENTRIC SHAFT	1	90	CALIBRATION LABEL	1

No.	Description	Q'ty	No.	Description	Q'ty
41	MIDDLE PULLEY	1	91	ANGLE LABEL	1
42	BEARING 6202	2	92	HEXAGON BAR WRENCH 4	1
43	CIRCLIP FOR HOLE 35	1	93	SWITCH PANEL	1
44	BELT O-565	1	94	PROTECTOR RING 22	1
45	BELT O-500	1	95	CORD CLAMP	1
46	SPINDLE PULLEY	1	96	NUT M5	1
47	CIRCLIP FOR HOLE 40	2	97	HEXAGON BAR WRENCH 3	1
48	KEYWAY SPINDLE	1	98	CROSS RECESSED PAN HEAD SCREW	1
49	BEARING 6203	2	99	HOOP FOR KEY WRENCH	1
50	TOOTH LOCK WASHER 5	1	100	LED LIGHT	1

Troubleshooting

Symptom	Possible Cause(s)	Corrective Action
Noisy operation	<ol style="list-style-type: none"> 1. Incorrect belt tension 2. Dry spindle 3. Loose spindle 4. Loose motor pulley 	<ol style="list-style-type: none"> 1. Adjust tension 2. Lubricate spindle 3. Tighten pulley nut 4. Tighten set screw in pulley
Bit burns or smokes	<ol style="list-style-type: none"> 1. Incorrect speed 2. Chips not coming out of hole 3. Dull bit 	<ol style="list-style-type: none"> 1. Change speed 2. Retract bit frequently to clear chips 3. Sharpen or replace bit
Excessive drill bit run out or wobble	<ol style="list-style-type: none"> 1. Bent bit 2. Bit not properly installed in chuck 3. Chuck not properly installed 4. Worn spindle bearings 	<ol style="list-style-type: none"> 1. Replace bit 2. Install bit properly 3. Install chuck properly 4. Replace bearings
Drill bit binds in workpiece	<ol style="list-style-type: none"> 1. Workpiece pinching bit or excessive feed pressure 2. Improper belt tension 	<ol style="list-style-type: none"> 1. Support or clamp workpiece, decrease feed pressure 2. Adjust tension
Workpiece torn loose from hand	<ol style="list-style-type: none"> 1. No supported or clamped properly 	<ol style="list-style-type: none"> 1. Support or clamp workpiece properly

Replacement Parts

- For replacement parts and technical questions, please call Customer Service at **1-800-222-5381**.
- Not all product components are available for replacement. The illustrations provided are a convenient reference to the location and position of parts in the assembly sequence.
- When ordering parts, the following will be required: model number, serial number/lot date code, and description.
- The distributor reserves the rights to make design changes and or improvements to product lines and manuals without notice.

Limited Warranty

Northern Tool and Equipment Company, Inc. ("We" or "Us") warrants to the original purchaser only ("You" or "Your") that the Klutch product purchased will be free from material defects in both materials and workmanship, normal wear and tear excepted, for a period of **one year** from date of purchase. The foregoing warranty is valid only if the installation and use of the product is strictly in accordance with product instructions. There are no other warranties, express or implied, including the warranty of merchantability or fitness for a particular purpose. If the product does not comply with this limited warranty, Your sole and exclusive remedy is that We will, at our sole option and within a commercially reasonable time, either replace the product or product component without charge to You or refund the purchase price (less shipping). This limited warranty is not transferable.

Limitations on the Warranty

This limited warranty does not cover: (a) normal wear and tear; (b) damage through abuse, neglect, misuse, or as a result of any accident or in any other manner; (c) damage from misapplication, overloading, or improper installation; (d) improper maintenance and repair; and (e) product alteration in any manner by anyone other than Us, with the sole exception of alterations made pursuant to product instructions and in a workmanlike manner.

Obligations of Purchaser

You must retain Your product purchase receipt to verify date of purchase and that You are the original purchaser. To make a warranty claim, contact Us at 1-800-222-5381, identify the product by make and model number, and follow the claim instructions that will be provided. The product and the purchase receipt must be provided to Us in order to process Your warranty claim. Any returned product that is replaced or refunded by Us becomes our property. You will be responsible for return shipping costs or costs related to Your return visit to a retail store.

Remedy Limits

Product replacement or a refund of the purchase price is Your sole remedy under this limited warranty or any other warranty related to the product. We shall not be liable for: service or labor charges or damage to Your property incurred in removing or replacing the product; any damages, including, without limitation, damages to tangible personal property or personal injury, related to Your improper use, installation, or maintenance of the product or product component; or any indirect, incidental or consequential damages of any kind for any reason.

Assumption of Risk

You acknowledge and agree that any use of the product for any purpose other than the specified use(s) stated in the product instructions is at Your own risk.

Governing Law

This limited warranty gives You specific legal rights, and You also may have other rights which vary from state to state. Some states do not allow limitations or exclusions on implied warranties or incidental or consequential damages, so the above limitations may not apply to You. This limited warranty is governed by the laws of the State of Minnesota, without regard to rules pertaining to conflicts of law. The state courts located in Dakota County, Minnesota shall have exclusive jurisdiction for any disputes relating to this warranty.



Distributed by:

Northern Tool and Equipment Company, Inc.

Burnsville, Minnesota 55306

www.NorthernTool.com

Made in China