

REEL ROTATOR ATTACHMENT - PEL-RR

APPROX WEIGHT: 38.77 lbs.
DOES NOT INCLUDE WEIGHT OF POWER OR PACKAGING!!!

*** ANY ADDITIONS, DELETIONS, OR OMISSIONS MUST BE CORRECTED ON THIS DRAWING AS THIS DRAWING WILL BE CONSIDERED ALL INCLUSIVE ***

ALL GRAPHICS PROVIDED ARE FOR REFERENCE ONLY. IF CERTAIN DIMENSIONS ARE CRITICAL PLEASE VERIFY THOSE DIMENSIONS WITH YOUR SALESPERSON

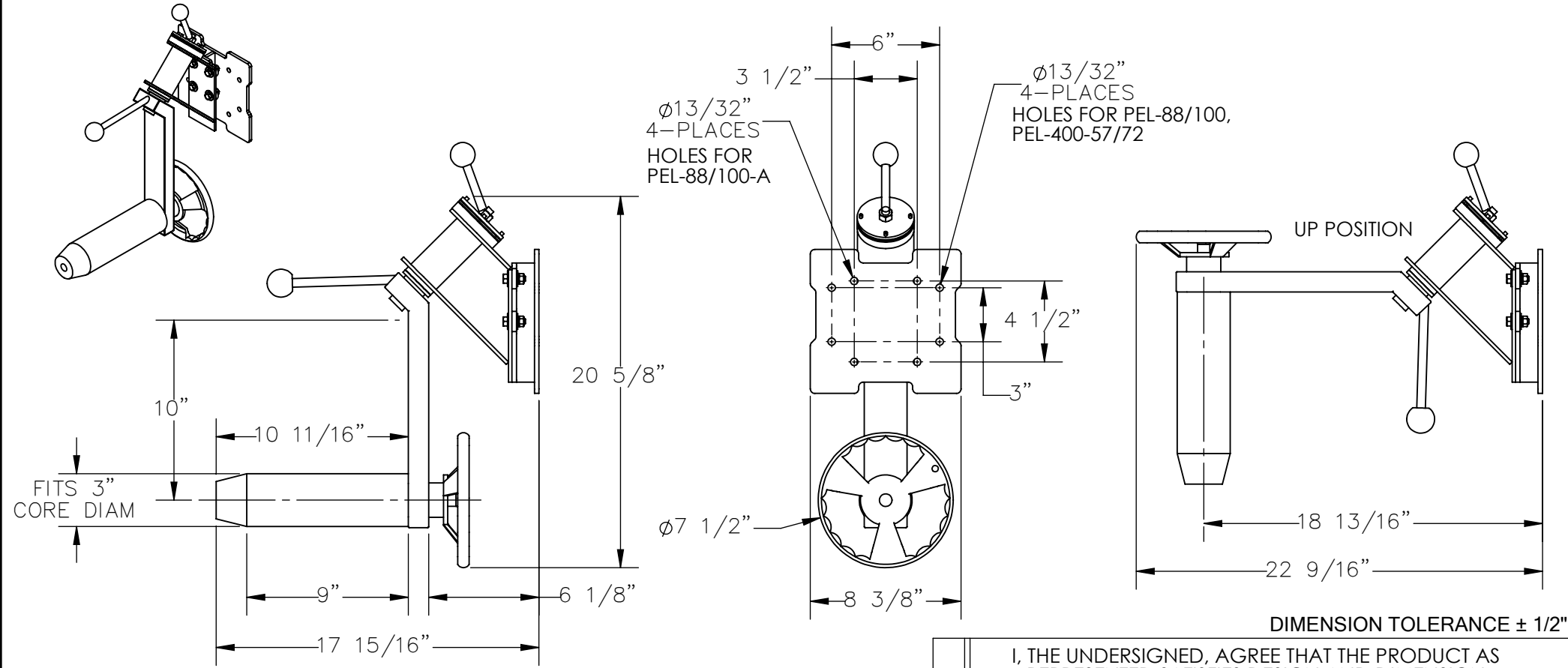

DIMENSION TOLERANCE ± 1/2"

STANDARD FEATURES

- MODEL NUMBER IS PEL-RR
- REEL ROTATOR ATTACHMENT MOUNTS TO:
PEL-88, PEL-100, PEL-88-A, PEL-100-A,
PEL-400-57, AND PEL-400-72
- PICKS UP AND ROTATES VERTICAL REELS
THROUGH 90° TO HORIZONTAL OR VICE VERSA
- SUITABLE FOR 3" CORE DIAMETER
- LENGTH OF ARBOR IS 10 11/16"
- USABLE LENGTH OF ARBOR IS 9"
- MAX UNIFORM CAPACITY IS 100 LBS
- OVERALL LENGTH IS 17 15/16"
- OVERALL WIDTH IS 8 3/8"
- OVERALL HEIGHT IS 23 5/8"

A P P R O V A L

I, THE UNDERSIGNED, AGREE THAT THE PRODUCT AS REPRESENTED SATISFIES DESIGN AND DIMENSION REQUIREMENTS. I ALSO ACKNOWLEDGE MY DUTY TO CONFIRM PRODUCT AND INSTALLATION COMPLIANCE WITH ALL APPLICABLE FEDERAL, STATE AND LOCAL REGULATIONS AND STANDARDS.

UNITS REQUIRING APPROVAL DRAWINGS OR MODIFIED ARE NON-RETURNABLE

[] As drawn [] As marked

Signed: _____ Date: _____

Printed Name: _____

LEAD TIME WILL START UPON RECEIPT OF SIGNED APPROVAL DRAWING

DISTRIBUTOR'S NAME:		P.O.#
VESTIL MANUFACTURING		X
DRAWN BY: SJA		DATE: 04/14/2016
REFERENCE: X		SCALE: 1:8
QUOTED LEAD TIME: X		QUOTE # X
		SALES: X
		FILE NAME: 21-007-122