



VORTEX
venting solutions / solutions d'évents

Heavy Duty Flexible Liner

INSTALLATION INSTRUCTIONS

A MAJOR CAUSE OF CHIMNEY RELATED FIRES IS FAILURE TO MAINTAIN REQUIRED CLEARANCES (AIR SPACES) TO COMBUSTIBLE MATERIALS. IT IS OF THE UTMOST IMPORTANCE THAT THIS HEAVY DUTY FLEXIBLE LINER BE INSTALLED ONLY IN ACCORDANCE WITH THESE INSTRUCTIONS.

This heavy duty flexible liner meets the requirements of the NFPA 211, UL 1777, ULC S635 and CAN/ULC S640 Standards.

Read through these instructions before beginning your installation. Failure to install according to these instructions will void the manufacturer's warranty and may have an effect on your homeowner's insurance and UL and ULC Listing status.

READ AND KEEP THIS MANUAL FOR REFERENCE

TABLE OF CONTENT

Product Information	3
General Product Information	3
Product Applications	3
Chimney Inspection and Cleaning.....	3
Clearances.....	4
Sizing the Liner.....	4
Insulation Requirements.....	5
For Solid Fuel Applications-	5
For Oil or Gas Applications-	5
Vortex Liner System Materials.....	5
Installation Instructions	6
1- Preparing the Liner for Installation	6
2- Insulating the Liner (if required).....	6
3- Installing the Liner	7
4- Completing the Top Termination	8
5- Completing the bottom termination	9
6- Congratulations!	10
Reference Diagrams for: Chimney Connector Systems and Clearances from Combustible Walls for Residential Heating Appliances.....	11
Maintenance Instructions	12
Warning For Solid Fuel Applications.....	12
Maintenance Procedures	12
Additional Information	13
VORTEX LIMITED LIFETIME WARRANTY	14

PRODUCT INFORMATION

GENERAL PRODUCT INFORMATION

The quality and workmanship of **Vortex** is reflected in the recognition by an accredited laboratory has given these products. The rigorous UL and ULC testing requirements, is your assurance of consistent quality in materials and manufacturing standards used for these lining systems. In addition, the industry leading Warranty on **Vortex** is a further indication of our confidence in the quality of these products. Thank you for choosing **Vortex**!

The **Vortex** stainless steel lining systems are listed in 3” (7.6cm) to 12” (30.5cm) diameters.

The lining system must be installed by a qualified chimney or venting professional.

The criteria for installation must be in conformance with the specifications in the NFPA 211 (Standards for Chimneys, Fireplaces, Vents and Solid Fuel Burning Appliances), National Building Code of Canada and local or state building codes, whichever has jurisdiction. **Contact local building or fire officials about restrictions and installation inspection in your area.** It may be necessary to obtain permits before installing the chimney liner. Contact the local building authority for permit information.

PRODUCT APPLICATIONS

The **Vortex** lining system is intended for use with heating appliances burning home heating oil, natural or LP gas and solid fuels (pellet, wood and coal) vented through a masonry chimney. Use of experimental fuels is not permitted and voids the warranty. This lining system is not intended for use with high efficiency appliances that require type BH gas venting systems, or that create positive pressures in the chimney.

The **Vortex** system is intended for use in (1) new masonry chimneys, lined or unlined, with at least (a nominal) 4”(10cm) of masonry all around, (2) an existing, properly built masonry chimney with cracked clay tile liner. The lining system is intended to provide a properly-sized flue for a heating appliance installed in a masonry chimney that otherwise meets existing codes.

The **Vortex** liner may also be used as a flue for a fireplace. The liner must be connected to the top of the smoke chamber by means of a bottom plate or other means, which provides an air-tight and drip-free termination.

CHIMNEY INSPECTION AND CLEANING

Prior to installation of the lining system thoroughly inspect and clean the chimney. All creosote (including tar glaze creosote), soot, dirt and debris must be removed before the installation of the liner. Thorough cleaning of the chimney is a warranty prerequisite. The chimney must be inspected for cracked, loose or missing- stones, bricks or mortar joints. A chimney that is not structurally sound should not be relined. Make any repairs necessary before proceeding with the installation of the liner.

As a precaution it is recommended that a short piece of lining material of the diameter to be installed is connected to a pulling cone and is drawn through the masonry chimney. This will ensure that no obstructions exist that should be removed and will result in a smoother installation of the system.

CLEARANCES

Inside the masonry chimney:

Minimum air space clearance of the liner to the interior surfaces of the masonry chimney to be maintained is zero millimetres (inches). The flue passageway must be checked for the smooth installation of the proper diameter liner. The chimney must be built of solid masonry brick, block or concrete blocks at least (a nominal) 4 inches (10cm) in thickness.

Exterior of Masonry Chimney:

The surrounding chimney construction shall comply with the NFPA 211 code, CAN/CSA-A405, Design and Construction of Masonry Chimneys and Fireplaces and/or the National Building Code of Canada. Clearance to combustibles must meet or exceed the requirements contained in the above mentioned codes, all applicable local building codes, and the manufacturer's installation requirements. Note insulation requirement section, which can permit zero clearance from exterior of masonry to combustibles in some cases.

Termination Above Roof:

The termination of chimney above a roof must be in accord with the requirements contained in the NFPA 211 code and/or CAN/CSA-A405. This code requires that a chimney terminate at least 3feet (0.9m) above the point where it penetrates the roof and 2 feet (0.6m) higher than any structure within a 10 foot (3m) radius. All **Vortex** installations must utilize a listed chimney cap.

Wall Penetration:

For wall or chimney penetrations other than listed in our installation instructions consult the NFPA 211 code and/or CAN/CSA A405 code and any other local codes. Wall penetration assemblies cannot be located directly behind a heating appliance.

SIZING THE LINER

For Solid Fuels, the liner is to be sized in accordance with the actual size (square inches or centimetres of the cross-sectional area) of the exhaust opening of the appliance, unless otherwise specified in the manufacturer's instructions. To determine the proper diameter of liner for Oil Burning Appliances refer to the NFPA 31 Oil Standard, the National Building Code of Canada, the Installation Code for Oil Burning Equipment, CAN/CSA B139, or the appliance manufacturer's instructions; for LP or Natural Gas Burning Appliances refer to the NFPA 54 Fuel Gas Code Book, CAN/CGA B149.1 and CAN/CGA B149.2 or the appliance manufacturer's instructions. Local and/or state building codes, whichever is the authority having jurisdiction, may specify other sizing requirements.

If the liner is for a fireplace chimney, the cross sectional area of a round liner is to be a minimum of 1/12th of the area of the face opening of the fireplace. Oval, square or rectangle shaped liners shall be a minimum of 1/10th of the area of the face opening of the fireplace.

The overall length of the lining system will be determined by the components required, the height of the masonry chimney and the top termination. The system should be a minimum of 8 feet (2.5m) in height but not greater than 75 feet (22m). If using two or more liner sections joined together by means of a connector, any connector should support no more than 50 feet (15m) of liner.

Ovalized, Rectangularized or Squarized Liner:

If a round liner will not fit the inside dimensions of a chimney, **Vortex** liners may be ovalized, rectangularized or squarized at our factory to allow for proper fit. Keep in mind any change in the original round shape of the liner will alter its cross-sectional area. Refer to Stove Builder International's shaped liner charts found in every brochure or call for calculation assistance when ordering factory approved, shaped liner. In fitting any factory-fabricated (ovalized, rectangularized or squarized) liner, you must ensure that you still maintain the required cross-sectional area of the liner required for the appliance to be connected. In addition, when installing a factory-fabricated shaped liner, a 1inch (25.4mm) clearance from the outside of the masonry chimney to the surrounding combustibles must be maintained.

INSULATION REQUIREMENTS

FOR SOLID FUEL APPLICATIONS-

Insulation provided for the **Vortex** system will be a single ½" (13mm) thick or two ¼" (6.5mm) layers of insulating blanket. This insulating system is listed to allow zero clearance from the chimney masonry exterior to combustibles. The 8 lb. density insulating blanket must be wrapped around the entire length of the liner in an unlined, partially lined, or cracked clay tile liner application.

Alternative EverGuard™ Insulation Mix or TherMix® Insulating method: The **Vortex** lining system can be insulated using EverGuard™ Insulation Mix or TherMix® brand insulating material. A 1-inch (25mm) layer of **EverGuard™ Insulation Mix** or TherMix® between the liner and 4 inch (10cm) nominal masonry provides a zero clearance listing from the chimney masonry exterior to combustibles. **If the clay tile liners are in good condition and the chimney meets existing codes, no insulation is necessary.**

FOR OIL OR GAS APPLICATIONS-

Vortex are listed to be installed without insulation for oil and gas appliances in an unlined, damaged clay tile lined, or good condition clay tile lined chimney. Oil and gas appliances do not require a minimum clearance between the outside of the liner and the inside of the masonry chimney. Stove Builder International has listed **Vortex** in this manner recognizing that insulation can cause clearance issues in certain masonry chimneys. However, it is good practice to insulate even with gas or oil appliances to stabilize draft and minimize condensation. One layer of ¼" (6.5mm) insulation is an excellent way to meet this need. See insulation installation instructions for further information.

VORTEX LINER SYSTEM MATERIALS

Use of any parts or materials not specified in this installation manual may not provide a listed system.

Approved Connections:

Approved connections of **Vortex** system are, (1) a tee section, (2) a listed direct connect system, (3) a connector directly attached to the heating appliance, (4) a masonry fireplace flue.

Approved Components:

Stove Builder International products have been tested by an accredited laboratory with the **Vortex** system. These approved components include, (1) Liner, (2) Top Plates, (3) Support Top Clamp, (4) Storm Collars, (5) Round Chimney Caps, (6) Screw Supports, (7) Tee connections, (8) Universal connectors, (9) Insulating wrap, (10) Retractable wire mesh, (11) Clamps to secure insulation, (12) Aluminum Foil Tape, (13) TherMix[®], (14) EverGuard[™] Insulation Mix, (15) Stainless steel self-tapping screws.

INSTALLATION INSTRUCTIONS

1- PREPARING THE LINER FOR INSTALLATION

(CAUTION- ENDS OF LINER AND EDGES OF CAP, TOP PLATE, TEE AND CONNECTORS CAN BE VERY SHARP! STOVE BUILDER INTERNATIONAL RECOMMENDS THE USE OF GLOVES AND SAFETY GLASSES DURING INSTALLATION.) (WARNING- WATCH OUT FOR OVERHEAD POWER LINES DURING INSTALLATION)

THE LINER IS DIRECTIONAL. EVERY LINER HAS TAPE THAT HAS AN ARROW AND “UP” ON ONE END. THE LOCK IS DIRECTIONAL SO IF INSTALLED UP-SIDE DOWN, CREOSOTE CAN GET ON THE OUTSIDE OF THE LINER.

- a) Remove the liner and components from the packaging. On a flat level surface roll out and straighten the lining material.
- b) Attach the necessary bottom termination connector, which may be a tee or a universal connector to the liner by inserting the liner into the connector as far as possible. Then, using a 5/16” (8mm) nut driver tighten the hose clamp band firmly around the liner. **Caution- do not over tighten the clamp!**
- c) To find the length of the liner needed, measure from the point at which the bottom connector will stop in the chimney to the top of the chimney crown and add 12” (30cm). This will be the total length of liner needed. Cut the liner to size as needed. When cutting the liner the use of an angled grinder with an abrasive wheel is recommended. It is possible to use a circular saw, or reciprocating saw with a metal cutting blade, but this use increases the risk that the lock gets broken and the liner may unravel. An already installed liner that is unraveling can be fixed with pop rivets. File or grind any rough or sharp edges for your safety.

2- INSULATING THE LINER (IF REQUIRED)

Method #1 Using Insulating Blanket Wrap

(CAUTION- FOIL EDGES OF INSULATION ARE VERY SHARP!)

- a) Always ensure that the bottom connector has been installed (tee or universal connector).
- b) The liner must be insulated from the bottom of the connector (in the case of a tee from where the tee cap is installed up and in the case of a universal connector from where the connector would stop on insertion into the heating appliance) to the crown. After determining this length, roll out the insulating wrap and cut to this length.
- c) The insulating wrap must overlap along its length by a minimum of 1” (2.5cm). To ensure you have the proper width of insulating wrap multiply the liner diameter by 3.14 plus 1” (2.5cm) for

- overlap. You may trim the width of the insulation to this amount but is not necessary. A wider overlap is allowed but may cause installation difficulties in tight clearance situations.
- d) With the insulating wrap rolled out (foil face on the ground) on a level surface, lay the liner and its bottom termination connector (which was previously attached) in the center of the insulation. At the bottom end of the insulation line up the bottom connector as outlined in step b) above. Remember that at the top the insulation will be even with the chimney crown.
 - e) Begin wrapping the insulation around the liner. After overlapping the wrap by at least 1” (2.5cm) hold the wrap in place at approximately 1 foot (30cm) intervals with foil tape. You may also use spray adhesive to assist you in holding the insulation against the liner.
 - f) Once insulation is in place apply a continuous vertical length of foil tape from the top to the bottom of the overlapped insulation seam.
 - g) Now encapsulate the insulated liner using retractable wire mesh. Unroll the correct size mesh and pull it over the entire length of insulated liner. At the bottom of the insulation secure the mesh and insulation in place with a stainless steel hose clamp. Now at the top of the liner, stretch the wire mesh tight and while holding mesh tight, clamp the insulation and wire mesh in place using a stainless steel hose clamp. Trim away excess mesh. With long liner lengths or tight clearances you may also wrap the entire length of insulated liner with stainless steel wire, spirally wrapped and then twisted on itself at each end to hold it in place. You are now ready to install the liner.

Method #2 Using EverGuard™ Insulation Mix or TherMix® Insulation

- a) **EverGuard™** Insulation Mix or **TherMix®** is poured into the chimney after the liner is installed. **EverGuard™** Insulation Mix or **TherMix®** is a pre-mixed insulation material that only requires the addition of water at the installation site.
- b) To prepare **EverGuard™** Insulation Mix or **TherMix®**, empty bag(s) into a mortar mixing box or wheelbarrow. Add 4 to 7 gallons (15 to 26.5 liters) of water per bag of **EverGuard™** Insulation Mix or 7 to 9 gallons (26.5 to 34 liters) of water per bag of **TherMix®** and mix with a hoe or other mixing tool. You have achieved the proper consistency and water content when the material is damp, but still granular. Squeeze a handful of your mixed material - little or no water should appear. Properly prepared **EverGuard™** Insulation Mix or **TherMix®** is able to be poured into the void between the liner and the chimney like “loose fill”.
- c) When pouring **EverGuard™** Insulation Mix or **TherMix®** between the liner and the chimney, distribute the material evenly around the liner. Spacers may be used to center the liner in the chimney cavity.
- d) Vibrate the liner by firmly tapping it and continue to pour in insulating material until the chimney is filled to the top. Be sure no **EverGuard™** Insulation Mix or **TherMix®** has fallen into the liner.
- e) All heating appliances or fireplaces can be fired right after installation. Keep flue gas temperatures below 700 degrees F (371 degrees C) for a period of three weeks. This allows for a gradual drying process of the insulating material.
- f) Remember a 1” (2.5cm) layer of **EverGuard™** Insulation Mix or **TherMix®** between the liner and 4” (10cm) nominal masonry provides a zero clearance listing from the chimney masonry exterior to combustibles.

3- INSTALLING THE LINER

Be sure to check above and around the chimney for antennas, power lines, or any other obstacles before beginning the installation. Be sure that the liner does not come in contact with electrical or any other wires.

- a) In some installations the use of a high quality pulling cone may be necessary.
- b) The height of the structure, roof pitch and other factors will influence how you determine to lower the liner into the chimney. Do not install a longer length of liner than the available manpower can handle.
- c) Lower the liner from the top of the chimney, keeping it centered in the flue opening and away from the edges. This will protect the liner and the insulating wrap. You may need to have someone at the bottom of the chimney with a rope (caution: do not use a metal conductive chain) attached to the pulling cone to assist in guiding the liner into the chimney. **DO NOT FORCE THE LINER INTO A CHIMNEY.** If the liner gets stuck while sliding it down the chimney, do not try to dislodge by rotating over 180° alternating clockwise and counterclockwise to avoid damaging the locking system.
- d) Once the bottom of the liner or bottom connector is at its desired position, trim the top of the liner to 4" (102mm) above the crown. For **Vortex** liners, it is necessary that the tee be secured and supported within the chimney in the case of long lengths of liner exceeding 35 feet (10.6m). This can be accomplished using angle iron.

4- COMPLETING THE TOP TERMINATION

- a) With the tee or universal connector held in place at the bottom, place a heavy bead of silicone caulk around the chimney crown or top of clay flue tile, if it extends above the crown. Place top plate over the liner and press firmly into silicone caulk. (Top plate may be trimmed as needed).
- b) Using a 5/16" (8mm) nut driver, tighten the hose clamp band around the liner. **Caution- do not over tighten the hose clamp band!** This secures the liner to the top plate. Optional: Top plate flashing has four predrilled holes, which can be used to Tapcon the top plate to the crown.
- c) Install the cap by fitting it over the collar of the top plate. Tighten the hose clamp band of the cap onto the top plate collar. Your top termination is now complete.

With Vortex Liner you have options ...

Hose clamp causing problems in tight clearance situations?

In some tight clearance installations, we realize the worm screw on the fastening hose clamp can cause problems. In these situations, remove the hose clamps and cut off the straps that secure the hose clamps to the tee or the universal connector. Then using four #8 X 3/4" (M4 X 20) self-tapping stainless steel screws (90 degrees apart) secure the liner to the connector or tee. It is necessary to use the "liner screw support" fitting, which slides inside the liner, at the female end of the connector or tee, for the strongest connection possible when using self-tapping screws. **This method of fastening still provides you with a listed system!**

Alternate Chimney Top Terminations for Vortex

The standard chimney top termination for a Vortex lining system is the use of a Vortex top plate and cap. However, some installations may require or you may desire an alternative top termination. Other chimney top terminations are approved as follows.

1. **Liner, mortar secured, to crown with any listed rain cap:** Insulate liner to within 4" (10cm) of chimney top. Fill the remaining 4"(10cm) with mortar or crown mix and form a slope from the liner to the outside edge of the chimney. Attach listed cap to the liner.
2. **Liner, mortar secured, to clay flue tile with any listed rain cap:** Insulate liner to within 4" (10cm) of chimney top. If not already existing, slip a full or partial length clay flue tile over the liner. Fill the gap between the clay flue tile and the chimney with mortar or crown mix and form a slope from the flue tile to the outside edge of the chimney. Fill the gap between the liner and the flue tile with mortar or crown mix. Attach listed cap to the liner.
3. **Slate Flue Covers:** In many residential communities slate flue coverings may be desirable. However, sufficient protection from precipitation and debris must be ensured. To make certain of this protection do the following: (1) Determine the distance between the top of the liner and the bottom of the slate covering, (2) Divide this measurement by 2.5, (3) This number gives you the minimum overhang of the covering past the edge of the liner. [Example: the covering is 12" (30cm) above the top edge of the liner. Divide 12" (30cm) by 2.5, which equals 4.8" (12cm). The covering must extend at least 4 ¾" (12cm) in all directions past the liner opening.] This provides a minimum 22.5 degree angle from liner edge to covering edge.

5- COMPLETING THE BOTTOM TERMINATION

Bottom Tee Terminations-

- a) Locate the point where the connector pipe will pass through the chimney to the tee body. There must be an opening large enough for the diameter of the connector pipe plus 2" (5cm).
- b) **If insulated-** cut away the wire mesh and insulating wrap where the removable snout will attach to the body of the tee. Only remove enough insulation to connect the snout.
- c) Secure the snout to the body of the tee using the attached metal band, which wraps around the backside of the tee body. Ensure that the snout is fitting properly to the tee body while securing the metal strap.

Note: certain size tees have fixed snouts.

- d) **If insulated-** wrap the snout (and any extension pipe used to extend beyond the exterior of the chimney face) with ½" (13mm) insulating wrap. Wrap the insulation a minimum of 1" (25mm) beyond the exterior of the chimney face. Remember the insulating wrap seam and where it meets the tee body insulation must overlap a minimum of 1" (25mm). The seam of the wrap and where it meets the tee body must be covered with foil tape. This snout insulation may be held in place with wire but is not necessary.
- e) Fill in the hole around the snout with brick and mortar.

- f) Complete your connection to the heating appliance following all applicable codes. Please see page 11 for reference diagrams of chimney connector systems and clearances from combustible walls for residential heating appliances.

Universal Connectors or other terminations-

- a) The universal connector may be connected to the exhaust collar of an appliance following the manufacturer's fastening specifications.

Universal Take-Off (UTO) Installation

The universal take-off (UTO) (B) may be used when additional gas or oil appliances need to be vented into a Vortex liner or when a UTO is used in place of a standard round tee section on an ovalized, rectangularized or squarized liner. When using a UTO the liner must be at least 1" (25mm) larger in diameter than the diameter of the UTO. To install a UTO:

1. If it does not exist cut a hole in the masonry chimney at the point where the UTO will be installed into the liner.
2. Cut a hole in the liner using the appropriate diameter hole saw (with a pilot drill bit). Make the pilot hole through the liner, then when cutting the main hole switch the drill to reverse. Press the hole saw into the liner firmly until the hole is cut completely through. Remove the cutout from the liner.
3. Feed the UTO draw band (C) around the liner (A) and into the turnbuckle. Tighten the draw band firmly around the liner.
4. Apply a bead of high-temp RTV silicone between the UTO and the liner.

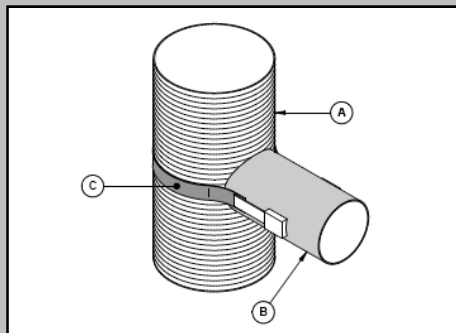

6- CONGRATULATIONS!

You've successfully completed your installation. Please review the maintenance and warranty information with the end-user. Your compliance with these installation instructions and applicable codes will ensure your customer long-lasting satisfaction.

Note: As with any venting system, the performance & safety of **Vortex** lining systems is dependent on the use of parts and materials specified in these instructions. Substitution of unauthorized parts may increase the risk of fire, appliance malfunction, property damage, personal injury or death. All installations must be in accordance with local codes, NFPA 211 standards, and/or the National Building Code of Canada, and the manufacturer's instructions.

REFERENCE DIAGRAMS FOR: CHIMNEY CONNECTOR SYSTEMS AND CLEARANCES FROM COMBUSTIBLE WALLS FOR RESIDENTIAL HEATING APPLIANCES

(Reprinted with the permission of the National Fire Protection Association, NFPA 211, 2000 edition)

System	Clearance (in.)(mm)
<p>A Minimum chimney clearance to brick and combustibles 2 in. (51 mm)</p> <p>Minimum chimney clearance to brick and combustibles 2 in. (51 mm)</p> <p>Minimum clearance 12 in. (305 mm) of brick</p> <p>Chimney flue</p> <p>Chimney connector</p> <p>Fire clay liner</p> <p>Masonry chimney constructed to NFPA 211</p> <p>Minimum 12 in. (305 mm) to combustibles</p>	12/305
<p>B Solid-insulated, listed factory-built chimney length of the same inside diameter as the chimney connector and having 1 in. (25.4 mm) or more of insulation with a minimum 9-in. (229-mm) air space between the outer wall of the chimney length and combustibles.</p> <p>The inner end of the chimney length shall be flush with the inside of the masonry chimney flue and shall be sealed to the flue and to the brick masonry penetration with non-water-soluble refractory cement. Supports shall be securely fastened to wall surfaces on all sides.</p> <p>Fasteners between supports and the chimney length shall not penetrate the chimney liner.</p> <p>Minimum chimney clearance from masonry to sheet steel supports and combustibles 2 in. (51 mm)</p> <p>Minimum clearance 9 in. (229 mm)</p> <p>Air space</p> <p>Chimney connector</p> <p>Use chimney mirrors parts to attach connector securely</p> <p>Solid-insulated, listed factory-built chimney length</p> <p>Sheet steel supports</p> <p>Masonry chimney constructed to NFPA 211</p> <p>Chimney flue</p> <p>Nonsoluble refractory cement</p> <p>Chimney length flush with inside of flue</p> <p>Factory-built chimney length</p> <p>Air space 9 in. (229 mm) min.</p>	9/229
<p>C Sheet steel chimney connector, minimum 24 gauge [0.024 in. (0.61 mm)] in thickness, with a ventilated thimble, minimum 24 gauge [0.024 in. (0.61 mm)] in thickness, having two 1-in. (25.4-mm) air channels, separated from combustibles by a minimum of 6 in. (152 mm) of glass fiber insulation. Opening shall be covered, and thimble supported with a sheet steel support, minimum 24 gauge [0.024 in. (0.61 mm)] in thickness.</p> <p>Supports shall be securely fastened to wall surfaces on all sides and shall be sized to fit and hold chimney section. Fasteners used to secure chimney section shall not penetrate chimney flue liner.</p> <p>Minimum chimney clearance to sheet steel supports and combustibles 2 in. (51 mm)</p> <p>Two air channels each 1 in. (25.4 mm)</p> <p>Chimney connector</p> <p>Minimum 6 in. (152 mm) glass fiber insulation</p> <p>Sheet steel supports</p> <p>Masonry chimney constructed to NFPA 211</p> <p>Chimney flue</p> <p>Two ventilated air channels each 1 in. (25.4 mm). Construction of sheet steel.</p>	6/152
<p>D Solid-insulated, listed factory-built chimney length with an inside diameter 2 in. (51 mm) larger than the chimney connector and having 1 in. (25 mm) or more of insulation, serving as a pass-through for a single wall sheet steel chimney connector of minimum 24 gauge [0.024 in. (0.61 mm)] thickness, with a minimum 2-in. (51-mm) air space between the outer wall of chimney section and combustibles.</p> <p>Minimum length of chimney section shall be 12 in. (305 mm). Chimney section concentric with and spaced 1 in. (25.4 mm) away from connector by means of sheet steel support plates on both ends of chimney section. Opening shall be covered, and chimney section supported on both sides with sheet steel supports of minimum 24 gauge [0.024 in. (0.61 mm)] thickness.</p> <p>Supports shall be securely fastened to wall surfaces on all sides and shall be sized to fit and hold chimney section. Fasteners used to secure chimney section shall not penetrate chimney flue liner.</p> <p>Minimum chimney clearance to sheet steel supports and combustibles 2 in. (51 mm)</p> <p>Minimum clearance 2 in. (51 mm)</p> <p>1-in. (25.4-mm) air space to chimney length</p> <p>Chimney connector</p> <p>Sheet steel supports</p> <p>Masonry chimney constructed to NFPA 211</p> <p>Chimney flue</p> <p>Sheet steel supports</p> <p>Chimney section</p> <p>Chimney connector</p> <p>Air space 2 in. (51 mm)</p>	2/51

Additional requirements:

- Insulation material used as part of wall pass-through system shall be of noncombustible material and shall have a thermal conductivity of 1.0 Btu-in./hr-ft²-°F (4.88 kg-cal/hr-m²-°C) or less.
- All clearances and thicknesses are minimums; larger clearances and thicknesses shall be permitted.
- Any material used to close up an opening for the connector shall be of noncombustible material.
- A connector to a masonry chimney, except for System B, shall extend in one continuous piece through the wall pass-through system and the chimney wall to the inner face of the flue liner, but not beyond.

MAINTENANCE INSTRUCTIONS

The lining system must be installed and serviced by a qualified chimney or venting professional. The criteria for the inspection and maintenance must be in conformance with local or state building codes, whichever has jurisdiction. It is recommended you use an inspection form and make notes that you can review with the homeowner.

It is recommended to clean thoroughly the pellet venting system after every heating season. During summer, the air is damper and with minimal air circulation within the venting system, it can mix with creosote and/or soot deposits in pipes to form an acid that could accelerate the corrosion process and induce premature decay of the steel.

WARNING FOR SOLID FUEL APPLICATIONS

“Creosote and Soot-Formation and Need for Removal: When wood is burned slowly, it produces tar and other organic vapors, which combine with expelled moisture to form creosote. The creosote vapors may condense on the inside of the chimney liner during slow-burning firing periods. As a result, creosote residue accumulates on the chimney liner. When ignited, this creosote makes an extremely hot fire.

The chimney lining system should be inspected at least once every two months during the heating season to determine if a creosote or soot buildup has occurred.

If creosote or soot has accumulated, it should be removed to reduce the risk of a chimney fire.”

MAINTENANCE PROCEDURES

It is important that the chimney lining system be checked and cleaned annually. This is for the safety of the homeowner and necessary to meet the warranty requirements of *Vortex*. As noted above in the case of solid fuel burning appliances more frequent maintenance may be required, depending on use. The entire system, from the connection at the appliance to the top of the liner, must be completely inspected and cleaned.

To clean the chimney lining system it is recommended to perform the following:

1. Remove cap
2. Select the proper sized nylon, poly or natural bristle chimney brush to clean the liner. Be sure the brush head passes throughout the complete length of the liner, including the connectors, terminals and tees.
3. In some instances, proper cleaning will require removing the appliance and disassembling the connector assembly to thoroughly inspect and clean parts that cannot be reached otherwise.
4. Inspect and clean the chimney cap. Spark arrestors and other screens may be necessary or required in some areas, but may be susceptible to blockage from creosote or through freezing moisture in areas of low ambient temperature.
5. Reinstall chimney cap.
6. Before the initial firing of the appliance, check the appliance’s operating instructions for initial firing precautions.

ADDITIONAL INFORMATION

1. *Vortex* lining systems are intended for use with heating appliances, burning home heating oil, natural or LP gas and solid fuels (pellet, wood, and coal). Use of experimental fuels is not permitted and voids warranty.
2. Use only components listed for use with the *VORTEX* lining system.
3. For solid-fuels, the chimney liner is not to be sized less than that specified in the appliance manufacturer's instructions.
4. If not in place, post notices near the point where the connection is made to the gas vent or roof jack, concerning limitations to use with either gas or gas and oil appliances only, when a liner is for use with either gas or gas and oil fuel only.

VORTEX LIMITED LIFETIME WARRANTY CHIMNEY LINING SYSTEM

The warranty:

The manufacturer’s warranty applies only to the original purchaser and is not transferable. Subject to the conditions and exclusions set forth below, the manufacturer warrants that its products will be free from manufacturing if properly installed. This warranty only covers replacement of defective liner components in a residential installation. This warranty is void if the chimney relining pipe is used in a different application than what it is designed for. This warranty is the sole and exclusive remedy, offered in lieu of all other warranties, expressed or implied.

Warranty conditions:

The warranty of the chimney lining system and its components are subject to the following conditions:

- 1) Brand new products with proof of purchase only;
- 2) Products must have been purchased from an authorized *SBI* dealer;
- 3) Installation in accordance with the instructions supplied with this product and all local and national building codes;
- 4) Normal use with a residential heating appliance that has been certified by an accredited laboratory (oil, natural, LP gas, solid fuels, pellet, wood or coal);
- 5) The liner is designed to operate at a maximum continuous temperature of 650 degrees Celsius (degrees 1200 Fahrenheit) or less;
- 6) The chimney lining system must be cleaned and inspected on an annual basis by a chimney professional at intervals of no more than 12 months each, starting at the date of purchase and as long as the warranty period applies. Receipts verifying that maintenance was performed must be kept;
- 7) Products under this warranty must have been produced after the date indicated on the cover page of this document;
- 8) The liner must have a cap installed;
- 9) Parts or components from other manufacturers are not covered by this warranty.

Warranty application in the case of a replacement:

	Parts	Labour
1 to 10 years¹	100% (100% of the purchase price at the time of the replacement)	n/a
11 to 15 years¹	50% (a 50% rebate applies to the purchase price at the time of the replacement)	n/a
16+ years¹	25% (a 25% rebate applies to the purchase price at the time of the replacement)	n/a

¹ From the date of purchase.

Liner caps – Part replacement covered at 100% for 5 years from the date of purchase.

The manufacturer may, at its discretion, fully discharge all obligations with respect to this warranty by refunding the wholesale price of any warranted but defective parts or supply any replacement parts under warranty without any charge.

Warranty exclusions:

This warranty does not cover:

- 1) Labour and installation costs;
- 2) Products that have been altered, modified or repaired since shipment from factory;
- 3) Products that have been moved from their original installation site;
- 4) Any non-stainless components mounted or connected to the chimney or venting system;
- 5) Damage (to products, appliances or structure) caused by misuse, abuse, improper installation, lack of maintenance, improper inspection or any other negligence;
- 6) This warranty does not cover incidental or collateral damages caused by smoke, fire, flood, strong winds, “acts of God”, or any other contingency beyond the manufacturer’s control;
- 7) Use of improper chimney brushes, chimney cleaners or any improper solvents/chemicals will void all applicable warranties;
- 8) Does not cover any solid fuel other than pellet, wood or coal;
- 9) Damage resulting from the use of driftwood, pressure-treated lumber, wood containing salt, chemicals, or any prohibited material will void all applicable warranties.

Claim process:

Shall your unit or any component be defective, contact immediately your *SBI* dealer. Prior to your call, make sure that you have the following information necessary for your warranty claim treatment:

- Your name, address and telephone number;
- Model name as indicated on the certification label or instruction sheets;
- Original invoice and dealer’s name;
- Nature of the defect and any relevant information.

Before shipping your unit or defective component to the manufacturer, you must first obtain a return authorization number. Supporting documents or digital pictures may be required to support the claim. Any merchandise shipped to the manufacturer without authorization will be refused automatically and returned to sender.



Distributed by:

Stove Builder International Inc.

250, rue de Copenhague, St-Augustin-de-Desmaures
(Quebec) Canada G3A 2H3

Tel: (418) 878-3040 Fax: (418) 878-3001