

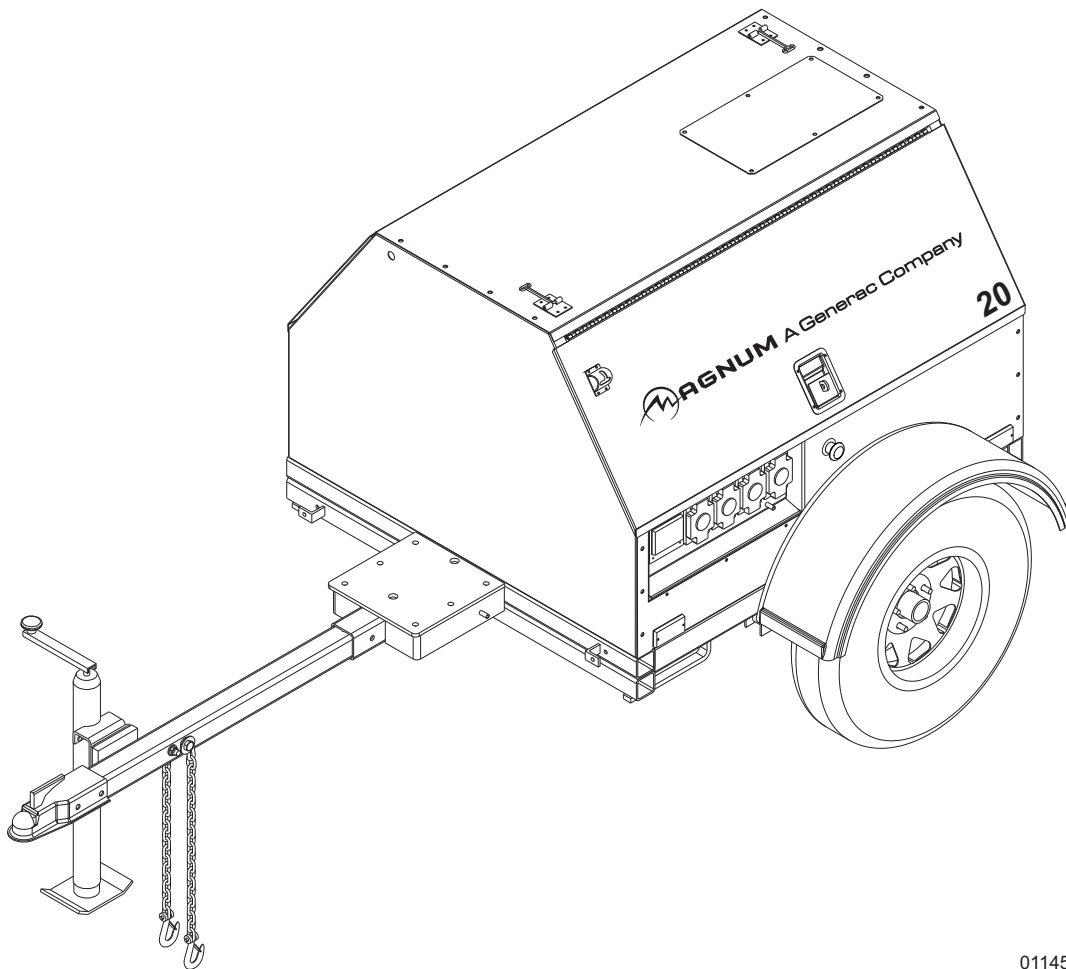

DIESEL GENERATOR MLG8 • MLG15 MLG20 • MLG20ICAN



OPERATING MANUAL

Parts manuals available online www.magnumpower.com

INTRODUCTION

This manual provides information and procedures to safely operate and maintain the Magnum Power Products LLC unit. For your own safety and protection from physical injury, carefully read, understand, and observe the safety instructions described in this manual. Keep a copy of this manual with the unit at all times. Additional copies are available from Magnum Power Products LLC, or can be found at www.magnumpower.com. *The information contained in this manual was based on machines in production at the time of publication. Magnum Power Products LLC reserves the right to change any portion of this information without notice.*

Read all of the manuals included with the unit. Each manual details specific information regarding items such as setup, use and service requirements. An engine operator's manual provides detailed operation and maintenance procedures for the engine. Additional copies of the engine operator's manual are available from the engine manufacturer.

DO NOT MODIFY or use this equipment for any application other than which it was designed for.

Magnum Power Products LLC recommends that a trained and licensed professional perform all electrical wiring and testing functions. Installation should be in compliance with the National Electrical Code (NEC), state and local regulations and Occupational Safety and Health Association (OSHA) guidelines.

MAGNUM POWER PRODUCTS LLC

215 Power Drive • Berlin, WI 54923

U.S.A.

Phone: 920-361-4442

FAX: 920-361-4416

Toll Free: 1-800-926-9768

www.magnumpower.com

For technical or parts **QUESTIONS**, please contact the Magnum Power Products LLC Customer Support or Technical Support team at 1-800-926-9768. Please have your serial number available.

To **ORDER SERVICE PARTS**, please contact the dealer from which you purchased the unit, or call Magnum Power Products LLC to locate a dealer in your area.

Engine Make: _____

Engine Serial Number: _____

Engine Model Number: _____

Generator Make: _____

Generator Model Number: _____

Generator Serial Number: _____

Unit Model Number: _____

Unit Serial Number: _____

▲ WARNING

CALIFORNIA PROPOSITION 65 WARNING: Diesel engine exhaust and some of its constituents are known to the state of California to cause cancer, birth defects and other reproductive harm.

TABLE OF CONTENTS

	Page
INTRODUCTION	2
SAFETY NOTES	4
OPERATING SAFETY	4
ENGINE SAFETY	4
SERVICE SAFETY	5
TOWING SAFETY	6
REPORTING TRAILER SAFETY DEFECTS	6
SAFETY SYMBOL SUMMARY	7
SPECIFICATIONS - MLG8, MLG15.....	8
SPECIFICATIONS - MLG20, MLG20ICAN	9
UNIT SERIAL NUMBER LOCATIONS	10
COMPONENT LOCATIONS	11
MAIN CONTROL PANELS.....	12
PRESTART CHECKLIST	14
EMERGENCY STOP SWITCH	14
STARTING THE UNIT.....	14
AUTOMATIC SHUTDOWN	15
VOLTAGE REGULATION	15
DERATING FOR ALTITUDE	15
WET STACKING	15
RECEPTACLE PANEL.....	16
SHUTTING DOWN THE UNIT	16
TOWING THE UNIT	16
LIFTING THE UNIT	17
GENERAL MAINTENANCE	18
BASIC MAINTENANCE SCHEDULE - MITSUBISHI ENGINE	19
BASIC MAINTENANCE SCHEDULE - ISUZU ENGINE	20
JACK MAINTENANCE	21
TRAILER WHEEL BEARINGS	21
LOWER RADIATOR HOSE HEATER OPTION - USE AND MAINTENANCE.....	21
AC WIRING DIAGRAM - MLG8	22
AC WIRING DIAGRAM - MLG15, MLG20, MLG20ICAN	23
AC WIRING DIAGRAM - RECEPTACLE PANEL	24
AC WIRING DIAGRAM - RECEPTACLE PANEL OPTIONS (1 OF 2).....	25
AC WIRING DIAGRAM - RECEPTACLE PANEL OPTIONS (2 OF 2).....	26
DC WIRING DIAGRAM - MLG8	27
DC WIRING DIAGRAM - MLG15, MLG20, MLG20CAN	28
DC WIRING DIAGRAMS FOR OPTIONAL EQUIPMENT.....	29
TRAILER LIGHTS WIRING DIAGRAM	30
SERVICE LOG	31

SAFETY NOTES



This is the safety alert symbol. It is used to alert you to potential personal injury hazards. Obey all safety messages that follow this symbol to avoid possible injury or death.

This manual contains DANGERS, WARNINGS, CAUTIONS, NOTICES and NOTES which must be followed to prevent the possibility of improper service, damage to the equipment, personal injury or death. The following formatting options will apply when calling the reader's attention to the DANGERS, WARNINGS, CAUTIONS, NOTICES and NOTES.

▲ DANGER

INDICATES A HAZARDOUS SITUATION WHICH, IF NOT AVOIDED, WILL RESULT IN DEATH OR SERIOUS INJURY.

▲ WARNING

Indicates a hazardous situation which, if not avoided, could result in death or serious injury.

▲ CAUTION

Indicates a hazardous situation which, if not avoided, may result in minor or moderate injury.

NOTICE

Indicates a hazardous situation which, if not avoided, may result in property or equipment damage.

***Note:** Notes contain additional information important to a procedure and will be found within the regular text body of this manual.*

OPERATING SAFETY



Before using the unit, be sure to read and understand all of the instructions. This equipment was designed for specific applications; **DO NOT** modify or use this equipment for any application other than which it was designed for. Equipment operated improperly or by untrained personnel can be dangerous. Read the operating instructions and familiarize yourself with the location and proper use of all instruments and controls. Inexperienced operators should receive instruction from someone familiar with the equipment before being allowed to operate or set up the unit. The following points should be practiced at all times:

- The area immediately surrounding the unit should be dry, clean, and free of debris.
- Position and operate the unit on a firm, level surface.
- **NEVER** start a unit in need of repair.
- Make certain the unit is securely fastened to a good earthen ground. Follow the National Electrical Code (NEC), state and local regulations.
- **NEVER** operate the unit on a combustible surface.
- **NEVER** operate a unit while tired, distracted, or under the influence of drugs or alcohol.

ENGINE SAFETY



Internal combustion engines present special hazards during operation and fueling. Failure to follow the safety guidelines described below could result in severe injury or death. Read and follow all safety warnings described in the engine operator's manual. A copy of this manual was supplied with the unit when it was shipped from the factory.

- **DO NOT** run engine indoors or in an area with poor ventilation unless exhaust hoses are used. Diesel engine exhaust contains carbon monoxide, a deadly, odorless and colorless gas which, if inhaled,

can cause nausea, fainting or death. Make sure engine exhaust cannot seep into closed rooms or ventilation equipment.

- **DO NOT** operate the unit on a combustible surface.
- **DO NOT** fill fuel tank near an open flame, while smoking, or while engine is running. **DO NOT** fill tank in an enclosed area with poor ventilation.
- **DO NOT** operate with the fuel tank cap loose or missing.
- **DO NOT** touch or lean against hot exhaust pipes or engine cylinders.
- **DO NOT** clean air filter with gasoline or other types of low flash point solvents.
- **DO NOT** remove engine coolant cap while engine is hot.
- **DO NOT** operate the unit without a functional exhaust system. Prolonged exposure to sound levels in excess of 85 dB(A) can cause permanent hearing loss. Wear hearing protection when working around a running engine.
- Keep area around exhaust pipes and air ducts free of debris to reduce the chance of an accidental fire.
- Batteries contain sulfuric acid which can cause severe injury or death. Sulfuric acid can cause eye damage, burn flesh or eat holes in clothing. Protective eye wear and clothing are necessary when working on or around the battery. Always disconnect the negative (-) battery cable from the corresponding terminal before performing any service on the engine or other components.
- Shut the engine down if any of the following conditions exist during operation:
 1. Noticeable change in engine speed.
 2. Loss of electrical output.
 3. Equipment connected to the generator overheats.
 4. Sparking occurs.
 5. Engine misfires or there is excessive engine/generator vibration.
 6. Protective covers are loose or missing.
 7. If the ambient air temperature is above 120°F (49°C).

SERVICE SAFETY



This unit uses high voltage circuits capable of causing serious injury or death. Only a qualified electrician should troubleshoot or repair electrical problems occurring in this equipment.

- Before servicing, make sure the Control Power switch is turned to OFF, circuit breakers are open (OFF (O) position) and the negative terminal on the battery is disconnected. **NEVER** perform even routine service (oil/filter changes, cleaning, etc.) unless all electrical components are shut down.
- **NEVER** allow water to accumulate around the base of the unit. If water is present, **DO NOT** service.
- **NEVER** service electrical components if clothing or skin is wet. If the unit is stored outside, check the engine and generator for any moisture and dry the unit before use.
- **NEVER** wash the unit with a power washer or high pressure hose.
- Open the main circuit breaker before disconnecting battery cables.
- Keep all body parts, clothing, and other loose items away from moving parts on the unit.
- Make sure slings, chains, hooks, ramps, jacks, and other types of lifting devices are attached securely and have enough weight-bearing capacity to lift or hold the unit safely. Always remain aware of the position of other people around when lifting the unit.
- **NEVER** start the unit under load. The circuit breakers must be in the OFF (O) position when starting the unit.

- **ALWAYS** disconnect the negative (-) battery cable from the corresponding terminal before performing any service on the engine, generator or any other components. Remove the negative (-) battery cable from the corresponding terminal if the unit is to be stored or transported.
- Replace all guards and safety devices immediately after servicing.

TOWING SAFETY



Towing a trailer requires care. Both the trailer and vehicle must be in good condition and securely fastened to each other to reduce the possibility of an accident. Some states require that large trailers be registered and licensed, contact your local Department of Transportation office to check on license requirements for your particular unit.

- Check that the hitch and coupling on the towing vehicle are rated equal to, or greater than, the trailer's Gross Vehicle Weight Rating (GVWR).
- Check tires on trailer for tread wear, inflation, and condition.
- **NEVER** tow trailer using defective parts. Inspect the hitch and coupling for wear or damage.
- Make sure the trailer hitch and the coupling are compatible. Make sure the coupling is securely fastened to the vehicle.
- Connect safety chains in a crossing pattern under the tongue and **ATTACH THE BREAKAWAY CABLE TO THE REAR BUMPER OF THE TOWING VEHICLE**. Do not attach the cable to the trailer hitch.
- Make sure directional and brake lights on the trailer are connected and working properly.
- Check that all lug nuts holding wheels on are tight and none are missing.
- Maximum recommended speed for highway towing is 45 mph (72 km/h). Recommended off-road towing speed is not to exceed 10 mph (16 km/h) or less, depending on terrain.
- When towing, maintain extra space between vehicles and avoid soft shoulders, curbs and sudden lane changes. If you have not pulled a trailer before, practice turning, stopping, and backing up in an area away from heavy traffic.

REPORTING TRAILER SAFETY DEFECTS

If you believe your trailer has a defect which could cause a crash or could cause injury or death, you should immediately inform the National Highway Traffic Safety Administration (NHTSA) in addition to notifying Magnum Power Products LLC.

If NHTSA receives similar complaints, it may open an investigation; and if it finds that a safety defect exists in a group of vehicles, it may order a recall and remedy campaign. However, NHTSA cannot become involved in an individual problem between you, your dealer, or Magnum Power Products LLC.















To contact NHTSA, you may either call the Auto Safety Hotline toll-free at 1-888-327-4236 (TTY: 1-800-424-9153), go to <http://www.safercar.gov>; or write to:

Administrator
NHTSA
1200 New Jersey Avenue S.E.
Washington, DC 20590

You can also obtain other information about motor vehicle safety from <http://www.safercar.gov>.

SAFETY SYMBOL SUMMARY

This equipment has been supplied with numerous safety and operating decals. These decals provide important operating instructions and warn of dangers and hazards. Replace any missing or hard-to-read decals and use care when washing or cleaning the unit. Decal placement and part numbers can be found in the parts manual. Below is a summary of the intended meanings for the symbols used on the decals.

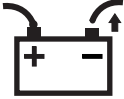
 <p>Safety alert symbol; used to alert you to potential personal injury hazards.</p>	 <p>Asphyxiation hazard; operate in well ventilated area.</p>
 <p>Hot surface(s) nearby.</p>	 <p>Dangerous voltage may be present.</p>
 <p>Belt/entanglement hazard; keep body parts clear of this area.</p>	 <p>Anchor/tie down point.</p>
 <p>Fan hazard; keep body parts clear of this area.</p>	 <p>Unit electrical ground.</p>
 <p>Stop engine before fueling.</p>	 <p>Use clean diesel fuel only.</p>
 <p>Fire/explosion hazard; keep open flames away from unit.</p>	 <p>Burn/scald hazard; pressurized steam.</p>
 <p>Read and understand the supplied operator's manual before operating unit.</p>	 <p>Lift here only.</p>
 <p>Remove negative battery cable before performing any service on unit.</p>	

00246

SPECIFICATIONS - MLG8, MLG15

MAGNUM MODEL	MLG8	MLG15
Engine		
Make/Brand.....	Mitsubishi.....	Mitsubishi
Model	L3E-W461ML.....	S4L2-Y461ML
EPA Tier	4f.....	4f
Horsepower - prime hp (kW)	10.5 (7.8).....	22.3 (16.6)
Horsepower - standby hp (kW)	12.2 (9.1).....	24.7 (18.4)
Operating Speed rpm	1800.....	1800
Displacement in³ (L)	58 (1).....	107 (1.8)
Cylinders - qty	3.....	4
Fuel Consumption - 100% prime gph (Lph)	0.63 (2.38).....	1.30 (4.92)
Battery Type.....	Group 24.....	Group 24
Battery Voltage (Quantity per Unit)	12V (1).....	12V (1)
Battery Rating	440 CCA.....	440 CCA
Generator		
Make/Brand.....	Marathon Electric.....	Marathon Electric
Model	332CSA3020.....	333CSA3024
Type, Insulation	Brushless, F.....	Brushless, F
Generator Set (Engine/Generator)		
3Ø - Standby kW (kVA)	N/A.....	N/A
Amps - 3Ø Standby 480V (208V) A	N/A.....	N/A
3Ø - Prime kW (kVA)	N/A.....	N/A
Amps - 3Ø Prime 480V (208V) A	N/A.....	N/A
1Ø - Standby kW (kVA)	7.3 (7.3).....	14.0 (14.0)
Amps - 1Ø Standby - 240V A	30.....	58
1Ø - Prime kW (kVA)	6.0 (6.0).....	13.0 (13.0)
Amps - 1Ø Prime - 240V A	25.....	54
Frequency Hz	60.....	60
Power Factor.....	1 (1Ø).....	1 (1Ø)
Sound dB(A) 23 ft @ prime	70.....	68
Dimensions (L x W x H) in (m)	105 x 68 x 56..... (2.67 x 1.73 x 1.42)	105 x 68 x 56..... (2.67 x 1.73 x 1.42)
Weights		
Dry Weight lbs (kg)	1030 (467).....	1425 (646)
Operating Weight lbs (kg)	1250 (567).....	1823 (827)
Capacities		
Fuel Tank Volume gal (L)	30 (114).....	56 (212)
Usable Fuel Volume gal (L)	30 (114).....	56 (212)
Coolant (incl. engine) qt (L)	4.5 (4.2).....	11.6 (11.0)
Oil (incl. filter) qt (L)	3.5 (3.3).....	6.7 (6.3)
Maximum Run Time hrs	48.....	43
AC Distribution		
Circuit Breaker Size	40.....	70
Voltage Selection	N/A.....	N/A
Voltage Regulation.....	+/- 1%.....	+/-1%
Voltages Available 1Ø.....	120, 240.....	120, 240
Voltages Available 3Ø.....	N/A.....	N/A
Trailer		
Number of Axles.....	1.....	1
Capacity - Axle Rating lbs (kg)	2200 (998).....	2200 (998)
Tire Size in	13.....	15
Brakes.....	N/A.....	N/A
Hitch - Standard.....	2" Ball.....	2" Ball
Maximum Tire Pressure psi	50.....	50

Specifications are subject to change without notice.

SPECIFICATIONS - MLG20, MLG20ICAN

MAGNUM MODEL	MLG20	MLG20ICAN
Engine		
Make/Brand.....	Isuzu	Isuzu
Model	4LE1NYGV-03	4LE1NYGV-03G
	4LE1NYGV-03E	
EPA Tier	4i	4i
Horsepower - prime hp (kW)	32.1 (23.9)	32.1 (23.9)
Horsepower - standby hp (kW)	35.3 (26.3)	35.3 (26.3)
Operating Speed rpm	1800	1800
Displacement in³ (L)	134 (2.2)	134 (2.2)
Cylinders - qty	4	4
Fuel Consumption - 100% prime gph (Lph)	1.80 (6.81)	1.80 (6.81)
Battery Type	Group 24	Group 24
Battery Voltage (Quantity per Unit)	12V (1)	12V (1)
Battery Rating	720 CCA	720 CCA
Generator		
Make/Brand.....	Marathon Electric.....	Marathon Electric
Model	334CSA3028	334CSA3028
Type, Insulation	Brushless, F	Brushless, F
Generator Set (Engine/Generator)		
3Ø - Standby kW (kVA)	N/A	N/A
Amps - 3Ø Standby 480V (208V) A	N/A	N/A
3Ø - Prime kW (kVA)	N/A	N/A
Amps - 3Ø Prime 480V (208V) A	N/A	N/A
1Ø - Standby kW (kVA)	20.0 (20.0)	20.0 (20.0)
Amps - 1Ø Standby - 240V A	83	83
1Ø - Prime kW (kVA)	19.0 (19.0)	19.0 (19.0)
Amps - 1Ø Prime - 240V A	79	79
Frequency Hz	60	60
Power Factor.....	1 (1Ø).....	1 (1Ø)
Sound dB(A) 23 ft @ prime	68	68
Dimensions (L x W x H) in (m)	105 x 68 x 56	105 x 68 x 56
	(2.67 x 1.73 x 1.42)	(2.67 x 1.73 x 1.42)
Weights		
Dry Weight lbs (kg)	1455 (660)	1455 (660)
Operating Weight lbs (kg)	1853 (841)	1853 (841)
Capacities		
Fuel Tank Volume gal (L)	56 (212)	56 (212)
Usable Fuel Volume gal (L)	56 (212)	56 (212)
Coolant (incl. engine) qt (L)	11.6 (11.0)	11.6 (11.0)
Oil (incl. filter) qt (L)	6.7 (6.3)	6.7 (6.3)
Maximum Run Time hrs	31	31
AC Distribution		
Circuit Breaker Size	100	100
Voltage Selection	N/A	N/A
Voltage Regulation	+/- 1%	+/- 1%
Voltages Available 1Ø	120, 240	120, 240
Voltages Available 3Ø	N/A	N/A
Trailer		
Number of Axles.....	1	1
Capacity - Axle Rating lbs (kg)	2200 (998)	2200 (998)
Tire Size in	15	15
Brakes	N/A	N/A
Hitch - Standard	2" Ball	2" Ball
Maximum Tire Pressure psi	50	50

Specifications are subject to change without notice.

UNIT SERIAL NUMBER LOCATIONS

Refer to the illustration to locate the unit ID tag and Vehicle Identification Number (VIN) tag on the unit. Important information, such as the unit serial number, model number, VIN and tire loading information are found on these tags. Record the information from these tags so it is available if the tags are lost or damaged. When ordering parts or requesting assistance, you may be asked to provide this information.

VIN Tag

MANUFACTURED BY MAGNUM POWER PRODUCTS, LLC MAGNUM POWER PRODUCTS, LLC		COUNTRY OF ORIGIN		DATE		SERIAL NUMBER	
MODEL		WEIGHT (LBS/KG)		TIRE SIZE		TIRE CLASSIFICATION	
VIN: 0000000000000000		MOTOR: XXXXXX		TYPE: TRAILER		TIRE AND LOADING INFORMATION SEE USER MANUAL	

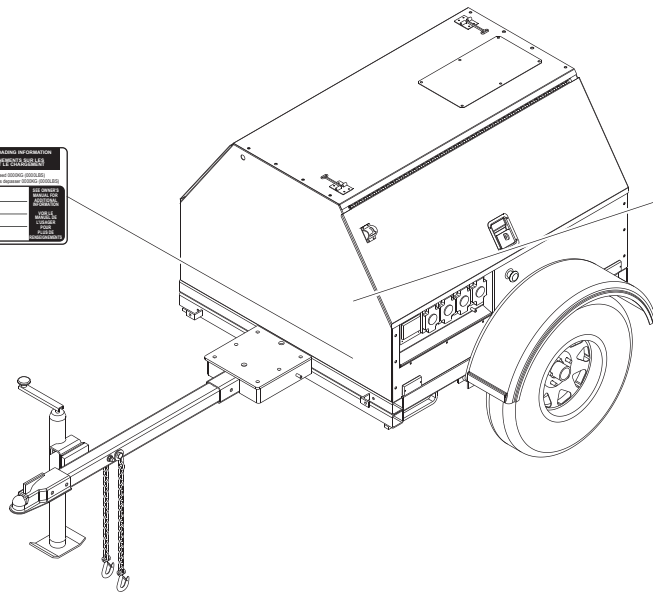

*Unit ID Tag
Located on
inside of panel*

Manufactured by Magnum Power Products, LLC, a subsidiary of Genesee Power Systems, Inc. (800) 361-4442 (800) 526-8768			
Country of Origin	Model	Serial Number	
Manufacturing Code	Weight (lbs/kg)	MPMP sequence	
1-ph. 120V	3-ph. 208V	Rating	
KVA		Inch. Class	
V			
A			

01146

COMPONENT LOCATIONS

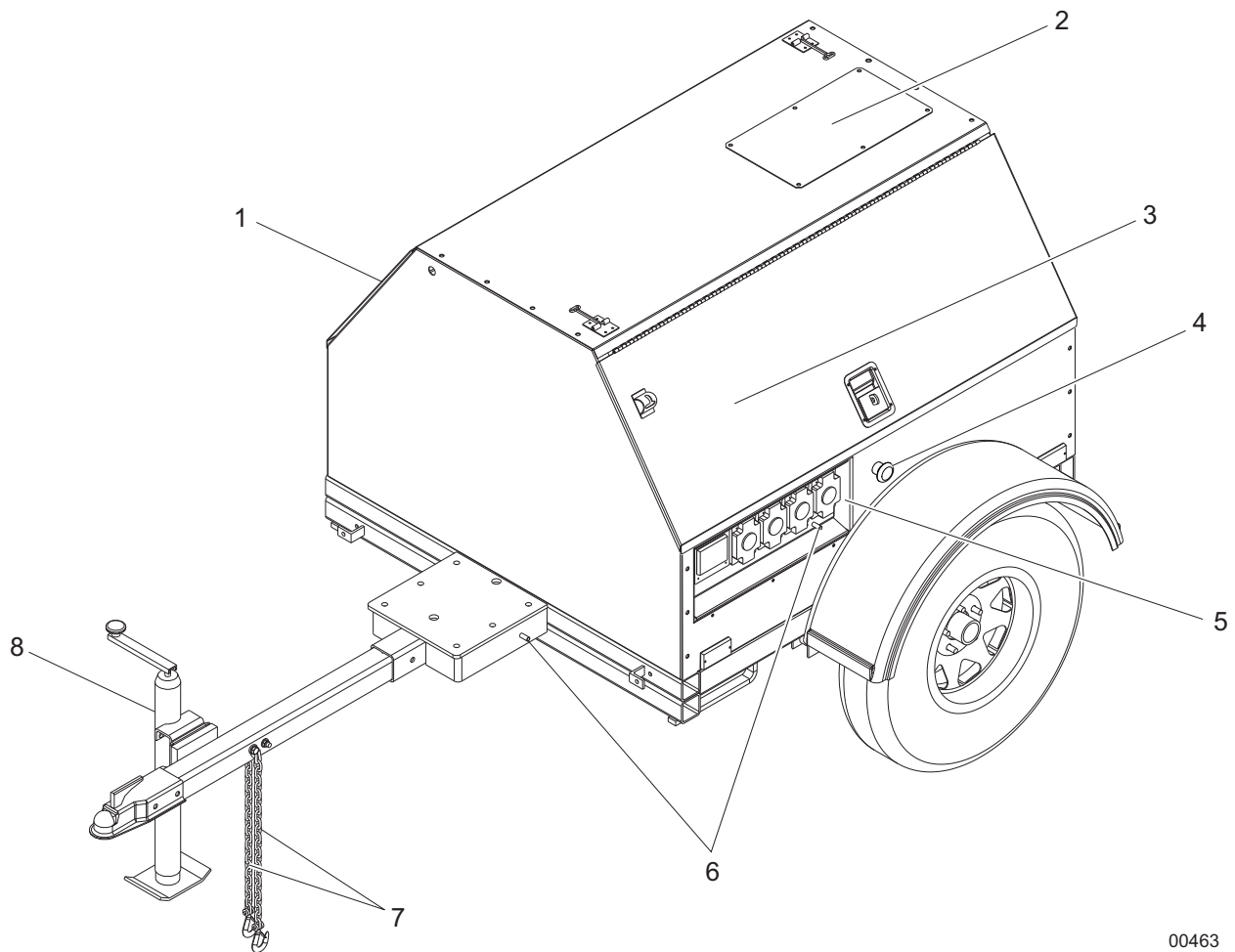

00463

1. **FUEL FILLER LOCATION (under door):** Use clean **DIESEL FUEL ONLY**.
2. **RADIATOR ACCESS PANEL:** Remove this panel for engine coolant service.
3. **CONTROL PANEL LOCATIONS (under door):** Refer to *“Main Control Panels” on page 12*.
4. **EMERGENCY STOP SWITCH (on MLG8 units the switch is located on the front panel):** For emergency shutdown; stops engine and trips main circuit breaker.
5. **RECEPTACLE PANEL (not available on MLG8 units):** Refer to *“Receptacle Panel” on page 16*.
6. **GROUND STUDS (2):** For grounding generator and equipment connected to the receptacle panel.
7. **SAFETY CHAINS:** Used in a crossing pattern under the tongue to attach unit to towing vehicle.
8. **TONGUE JACK:** Used to level the unit before starting.

MAIN CONTROL PANELS

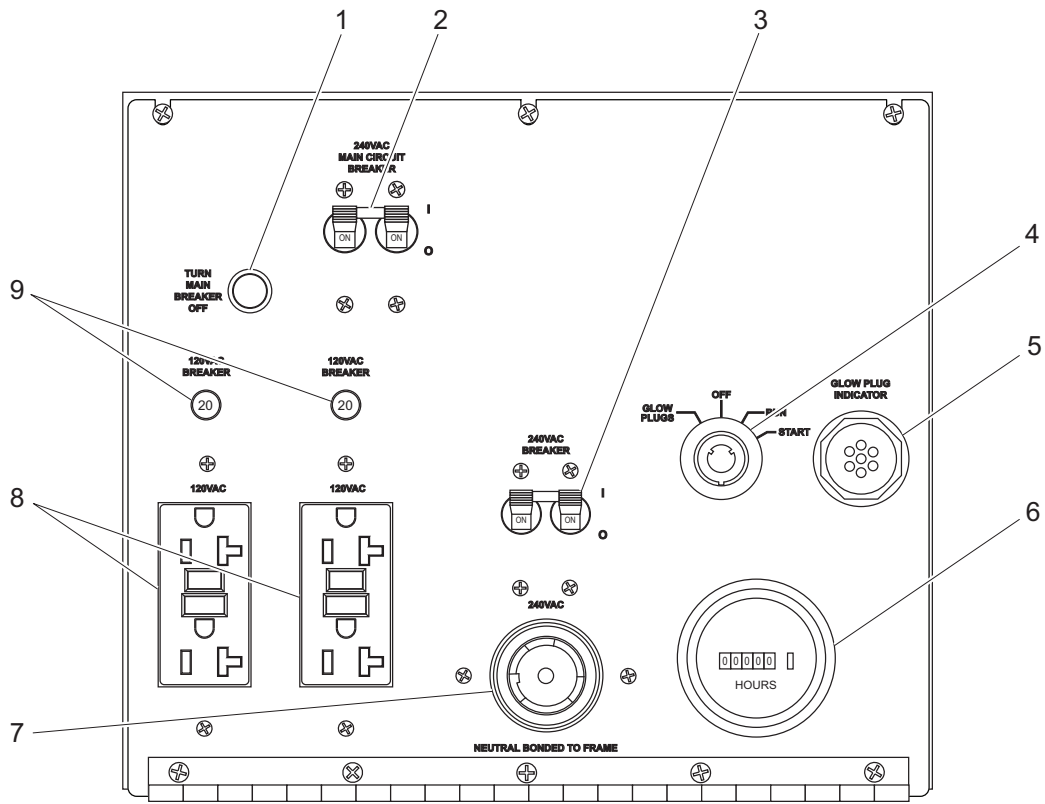

MLG8

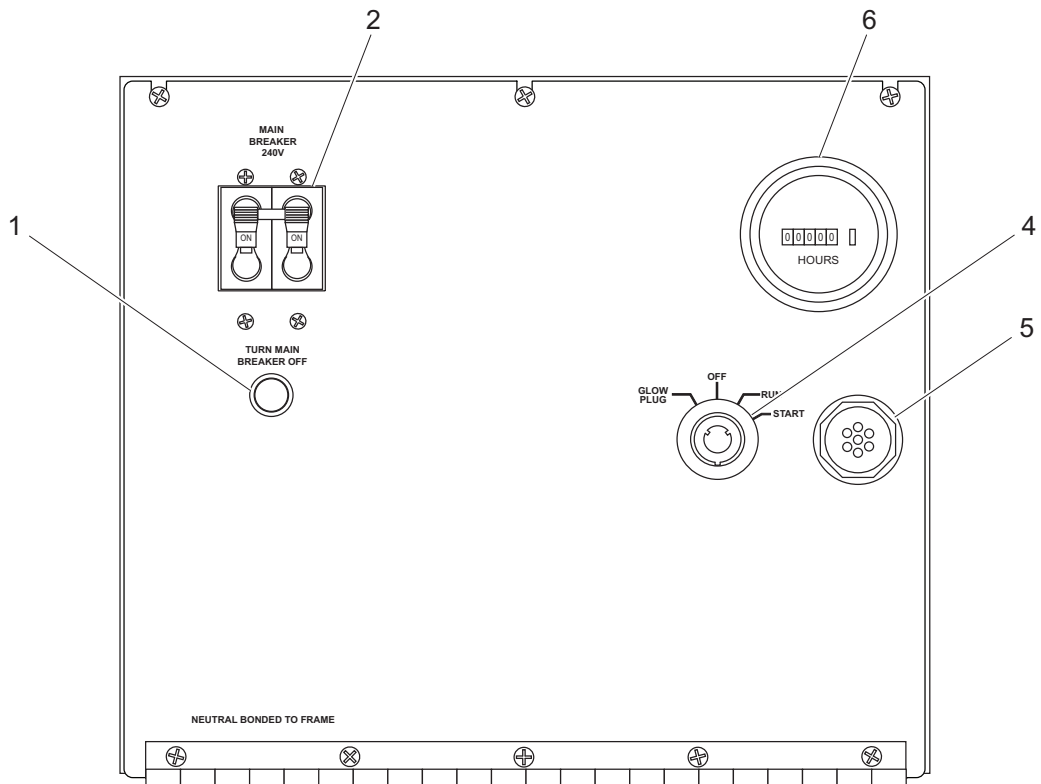

MLG15 • MLG20 • MLG20ICAN

00464

1. **CIRCUIT BREAKER INDICATOR LIGHT:** This light indicates that the main circuit breaker must be opened (switched off) before starting the engine.
2. **MAIN CIRCUIT BREAKER:** This breaker will disconnect power to the receptacle panel.
3. **240VAC CIRCUIT BREAKER:** This 240V (30A) breaker is supplied for the standard 240V twist-lock receptacle.
4. **CONTROL POWER SWITCH:** Keyed switch operates glow plugs and starts and stops engine.
5. **GLOW PLUG INDICATOR:** Indicates operation of the engine glow plugs.
6. **ENGINE HOUR METER:** Keeps track of engine hours for service.
7. **240V TWIST-LOCK RECEPTACLE:** This 240V (30A) receptacle supplies power for accessories connected to the generator when the engine is running and the main circuit breaker is switched to the "ON/I" position.
8. **120V GFCI RECEPTACLES:** This unit is equipped with two 120V (20A) GFCI receptacles to supply power for accessories connected to the generator when the engine is running and the main circuit breaker is switched "ON/I".
9. **120V BREAKER:** One 120V (20A) circuit breaker is supplied for each 120V GFCI receptacle.

PRESTART CHECKLIST

Before starting the unit, all items in the prestart checklist must be completed.

- Read and understand **ALL** safety sections at the beginning of this manual.
- Ensure all maintenance procedures are up to date. For more information, refer to *“General Maintenance” on page 18* and Basic Maintenance Schedules beginning on *page 19*.
- The unit must be level.
- The unit must be dry. Check for any water inside, on, or near the unit; dry if needed.
- Ensure the unit is properly grounded to a good earthen ground. Installation should be in compliance with the National Electrical Code (NEC), state and local regulations.
- Switch the Control Power switch to the OFF (O) position.
- Switch all circuit breakers to the OFF (O) position.
- Check oil, coolant, and fuel levels. For more information, refer to *“General Maintenance” on page 18*.
- Ensure engine battery connections are secure.
- Turn the battery disconnect switch on, if equipped.
- Check the engine fan belt tension and condition.
- Check the engine fan belt guard.
- Check the engine exhaust system for loose or rusted components.
- Ensure all covers are in place and secure.
- Ensure the emergency stop switch is pulled out.

EMERGENCY STOP SWITCH

The unit is equipped with one emergency stop switch. For location of the emergency stop switch, refer to *“Component Locations” on page 11*. The red switch is clearly labeled “EMERGENCY STOP.” The switch can be accessed and activated with all doors closed and locked.

Activate the emergency stop switch by pushing the red button in until it locks down. This will open the fuel circuit, shutting down the engine. The switch will remain locked until it is pulled out.

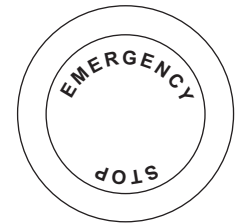

00230

NOTICE

Use the emergency stop switch only when the unit must be shut down immediately. For any other shut down, refer to *“Shutting Down the Unit” on page 16*.

STARTING THE UNIT

Note: *If the engine was run out of fuel or the fuel tank was drained, it may be necessary to bleed the fuel lines. Refer to the engine operator’s manual supplied with the unit.*

1. Check that the main circuit breaker and individual circuit breakers for each of the receptacles are in the OFF (O) position.

Note: *When the red Turn Main Breaker Off light is illuminated, the main circuit breaker must be turned the OFF (O) position.*

- Turn the key on the Control Power switch to the left Glow Plug position and hold the key in place for five seconds, or until the glow plug indicator turns red. As soon as it is glowing, turn the key to the right Start position and hold it until the engine cranks and starts running. Release the key, it will move to the Run position.

Note: For cold weather conditions, refer to the engine operator's manual for appropriate glow plug interval.

ACTIVATE GLOW PLUG

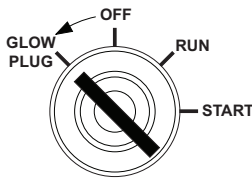

CRANK ENGINE TO START

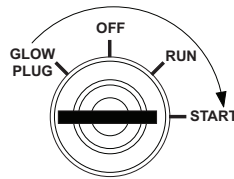

RELEASE KEY

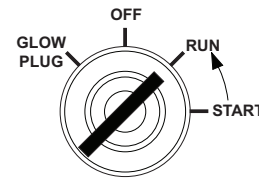

00203

NOTICE

Do not crank the engine longer than 10 seconds at a time. If the engine will not start, wait 30 seconds to allow the starter motor to cool and then repeat the starting procedure. Excessive cranking will cause damage to the starter.

Note: If oil pressure is not obtained within 15 seconds after the key is switched to the Run position, the low oil automatic shutdown will turn off the fuel supply, stopping the engine. Check the oil level and turn the key to the OFF position to reset the oil pressure timer before attempting to restart the engine.

- Once the engine is running, allow it to reach normal operating temperature before switching on any loads.

AUTOMATIC SHUTDOWN

This unit is equipped with a low oil pressure and high coolant temperature automatic shutdown system. This system will automatically shut off the fuel supply to stop the engine if oil pressure drops too low or the engine exceeds normal operating temperature. Return the switch to the OFF position to reset the unit after you have determined the cause of the shutdown.

VOLTAGE REGULATION

Units are equipped with an electronic voltage regulator. The voltage regulator controls the output of the generator by regulating the current into the exciter field. The regulator has three screwdriver adjustable potentiometers that may be adjusted for voltage, stability and voltage roll-off (U/F). The voltage regulator is adjusted before shipment from the factory. Contact Magnum Power Products LLC for additional information before attempting to adjust the voltage regulator.

DERATING FOR ALTITUDE

All units are subject to derating for altitude and temperature; this will reduce the available power for operating tools and accessories connected to the receptacles. Typical reductions in performance are 2-4% for every 1000 ft (305 m) of elevation and 1% per 10°F (5.6°C) increase in ambient air temperature over 72°F (22°C).

WET STACKING

The unit is powered by a diesel engine. Diesel engines are susceptible to wet stacking if lightly loaded. Wet stacking occurs when an engine is run at less than 30% of its full load capacity, causing unburned fuel to accumulate in the exhaust system. Wet stacking can be detected by continuous black exhaust when the unit is under a constant load. It can also cause fouling of injectors and buildup on engine valves. Diesel engines operate properly when applied loads are between 30% and 100% capacity. Appropriate generator sizing is determined by the anticipated load. If the unit is in a wet stack condition, load the unit heavily for five hours or until the exhaust is clear.

RECEPTACLE PANEL

The MLG15, MLG20, and MLG20ICAN models are equipped with a receptacle panel for running accessories or tools from the generator. Power is supplied to the receptacles any time the engine is running and the main circuit breaker is switched to the ON (I) position. Each receptacle has an individual circuit breaker, located inside the cabinet under a flip-up cover. Each circuit breaker corresponds with the receptacle located below it on the receptacle panel.

Should the main breaker, or any of the individual circuit breakers trip, remove some of the load to the receptacles before turning them back on.

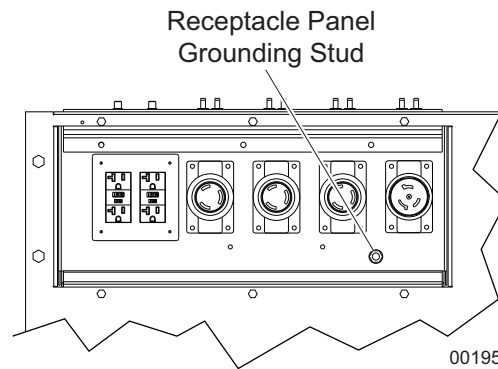

Note: To ensure proper grounding, anytime the generator is providing power to any equipment or load panels that do not have a grounded plug, a ground wire **MUST BE** added between the equipment and the grounding stud on the receptacle panel per the National Electrical Code (NEC), state and local regulations.

SHUTTING DOWN THE UNIT

Check with personnel using power supplied by the unit and let them know the power is going to be turned off. Make sure the power shut down will not create any hazards by accidentally turning off equipment that needs to be kept on (pumps, compressors, lights, etc.).

When you have finished using the unit, proceed with shut down as follows:

1. Remove any loads from the receptacles.
2. Switch the individual circuit breakers for each receptacle to the OFF (O) position.
3. Switch the main circuit breaker to the OFF (O) position.
4. Turn the Control Power switch to the OFF position.

Note: For extended storage time, disconnect the battery. For extended storage requirements, refer to the engine operator's manual.

TOWING THE UNIT

Once the engine is shut down, follow these steps to prepare the unit for towing.

1. Use the jack to raise or lower the trailer onto the hitch of the towing vehicle. Lock the hitch coupling and attach the safety chains or cables to the vehicle. Remove the jack locking pin and rotate the jack into the travel position. Replace the jack locking pin, ensuring it snaps into place.

Note: A film of grease on the coupler will extend coupler life and eliminate squeaking. Wipe the coupler clean and apply fresh grease each time the unit is towed.

2. To ensure proper operation of the jack, lube the grease fitting located on the leveling jack on the tongue. Refer to ["Jack Maintenance" on page 21](#). For maintenance interval information, refer to Basic Maintenance Schedules beginning on [page 19](#).
3. Connect any trailer wiring to the tow vehicle. Check for proper operation of the stop and signal lights.
4. Make sure the doors are properly latched.

5. Check for proper inflation of the trailer tires. Refer to the Specifications beginning on [page 8](#).
6. Check the wheel lugs. Tighten or replace any lugs that are loose or missing. If a tire has been removed for axle service or replaced, tighten the lugs in the order shown to the following specifications:

- A. Start all lug nuts by hand.
- B. First pass tighten to 20-25 ft-lbs (27-33 Nm).
- C. Second pass tighten to 50-60 ft-lbs (67-81 Nm).
- D. Third pass tighten to 90-120 ft-lbs (122-162 Nm).

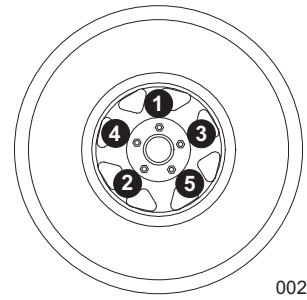

00204

Note: After the first road use, re-torque the lug nuts in sequence.

7. Maximum recommended speed for highway towing is 45 mph (72 km/h). Recommended off-road towing speed is not to exceed 10 mph (16 km/h) or less, depending on terrain.

LIFTING THE UNIT

When lifting the unit, attach any slings, chains or hooks directly to the central lift point.

1. Make sure the equipment being used to lift the unit has sufficient capacity. For approximate weights, refer to Specifications beginning on [page 8](#).
2. Always remain aware of people and objects around the unit while moving.
3. Use the forklift pockets with care. Approach the unit as perpendicular as possible to avoid any damage to the unit. Make sure any obstructions are clear of the forklift tines before lifting.

UNIT WITH STANDARD FORKLIFT POCKETS

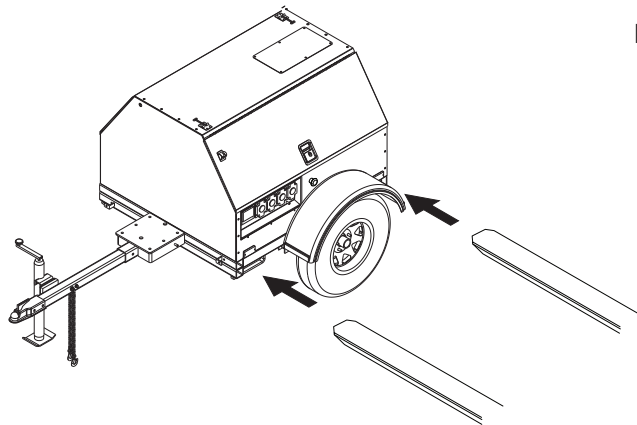

UNIT WITH OPTIONAL LIFT STRUCTURE

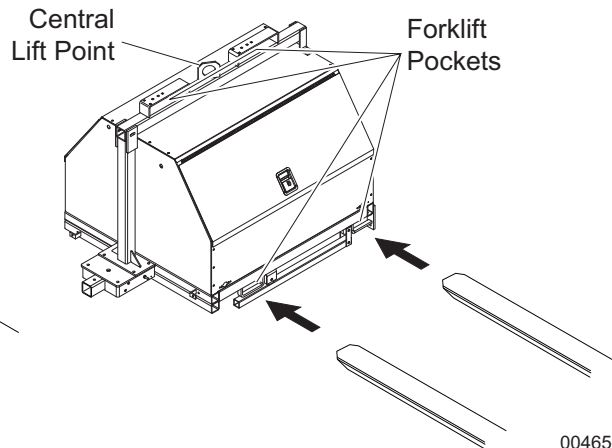

00465

GENERAL MAINTENANCE

Poorly maintained equipment can become a safety hazard. In order for the equipment to operate safely and properly over a long period of time, periodic maintenance and occasional repairs are necessary. **NEVER** perform routine service (oil/filter changes, cleaning, etc.) unless all electrical components are shut off. Before servicing the unit, always follow the instructions listed below.

- Ensure the Control Power switch is turned to the OFF (O) position.
- Ensure the circuit breakers are open OFF (O) position.
- Activate (push in) the emergency stop switch.
- Disconnect the negative (-) terminal on the battery.
- Attach a DO NOT START sign to the control panel. This will notify everyone that the unit is being serviced and will reduce the chance of someone inadvertently trying to start the unit.
- Never wash the unit with a high pressure hose or with any kind of power washer.
- Never wash the engine block or fuel tank with a power washer or steam cleaner. Water may enter the cabinet and collect in the generator windings or other electrical parts, causing damage.
- If the unit is stored outside, check for water inside the cabinet and generator before each use. If wet, dry the unit thoroughly before starting.
- Check the wheel lugs. Refer to *“Towing The Unit” on page 16*.
- Check coolant levels. Refer to the engine operator’s manual when determining proper mixture.
 - Coolant is checked visually by inspecting the level in the coolant overflow jug near the radiator.
 - Normal operation is between the FULL and ADD markings on the overflow jug, this is known as “Normal Range”.
 - **WHEN ENGINE IS STOPPED AND COMPLETELY COOL**, coolant may be added directly to jug.
- Check the oil levels. Refer to the engine operator’s manual when determining proper viscosity.
 - **DO NOT** start the unit if engine oil level is below the ADD mark on the dipstick.
 - Normal operation is between the FULL and ADD markings on the dipstick.
 - Add oil only if oil level is below cross-hatch pattern on the dipstick. **DO NOT OVERFILL** crankcase.
- Check fuel level.

Note: *During the first 100 hours of operation, avoid long periods of no load or sustained maximum load operation. If the unit is to run for longer than five minutes without a load, shut the engine down.*

BASIC MAINTENANCE SCHEDULE - MITSUBISHI ENGINE

NOTICE

Refer to the original equipment manufacturer's operating manual for a complete list of maintenance requirements. Failure to comply with the procedures as described in the engine operator's manual will nullify the warranty, decrease performance and cause equipment damage or premature equipment failure. Maintenance records may be required to complete a warranty request.

Use the schedule in the following table as a guide for regular maintenance intervals.

Item	Daily	50 Hours	250 Hours	400 Hours	500 Hours	1000 Hours	As Required
Check Oil Level	◆						
Check Coolant Level	◆						
Check Fuel Level	◆						
Check Tire Pressure	◆						
Check All Electrical Connections	◆						
Inspect Radiator Fins For Debris, Clean As Required	◆						
Fuel Tank - Drain Water		◆					
Check Air Cleaner		◆					
Replace Engine Oil and Oil Filter			◆*				
Belt and Belt Tension - Inspect and Adjust			◆				
Replace Fuel Filter				◆			
Drain and Clean Fuel Tank					◆**		
Check Glow Plugs					◆		
Lubricate Leveling Jacks					◆		
Bolts and Nuts On The Engine - Retighten						◆*	
Replace Heated Fuel Filter (If Equipped)						◆	
Inspect Engine Starting Battery						◆	
Air Cleaner Element - Clean, Check and Replace							◆
Fuel System - Bleed Air							◆
Water Sedimenter - Drain Water							◆

* Perform after the initial 50 hours of operation, then on the regularly scheduled interval indicated in the schedule above.

** Certain conditions may require the fuel tank to be drained and cleaned more often. When operating in extremely dusty conditions, clean the fuel tank as often as necessary.

BASIC MAINTENANCE SCHEDULE - ISUZU ENGINE

NOTICE

Refer to the original equipment manufacturer's operating manual for a complete list of maintenance requirements. Failure to comply with the procedures as described in the engine operator's manual will nullify the warranty, decrease performance and cause equipment damage or premature equipment failure. Maintenance records may be required to complete a warranty request.

Use the schedule in the following table as a guide for regular maintenance intervals.

Item	Daily	250 Hours	500 Hours	1000 Hours
Check Oil Level	◆			
Check Coolant Level	◆			
Check Fuel Level	◆			
Drain Fuel Filter	◆			
Check Tire Pressure	◆			
Check All Electrical Connections	◆			
Clean Battery	◆			
Check Fan Belt Tension (Replace If Necessary)	◆			
Inspect Radiator Fins For Debris, Clean As Required	◆			
Preheating Condition Check	◆			
Check Engine Starting Conditions and Noise Conditions	◆			
Check Exhaust Smoke Condition	◆			
Replace Engine Oil*		◆		
Replace Fuel Filter Element		◆		
Clean Water Sedimenter Element		◆		
Electromagnetic Pump Filter Replacement Or Cleaning		◆		
Check Fan Belt Tension (Replace If Necessary)			◆	
Oil Filter Element Replacement*			◆	
Replace Air Filter Element			◆	
Lubricate Leveling Jacks			◆	
Replace Heated Fuel Filter (If Equipped)				◆
Inspect Engine Starting Battery				◆

* Change the oil and oil filter after the first 50 hours (break-in period, one time)

JACK MAINTENANCE

The following procedures should be performed at least annually.

SIDE-WIND MODELS

- The internal gearing and bushings of the jack must be kept lubricated. Apply a small amount of automotive grease to the internal gearing by removing the jack cover, or if equipped, use a needle nose applicator or standard grease gun on the lubrication point found on the side of the jack near the crank. Rotate the jack handle to distribute the grease evenly.
- A lightweight oil must be applied to the handle unit at both sides of the tube.
- If equipped, the axle bolt and nut assembly of the caster wheel must also be lubricated with the same lightweight oil.

TOP-WIND MODELS

- Apply a lightweight oil to the screw stem.

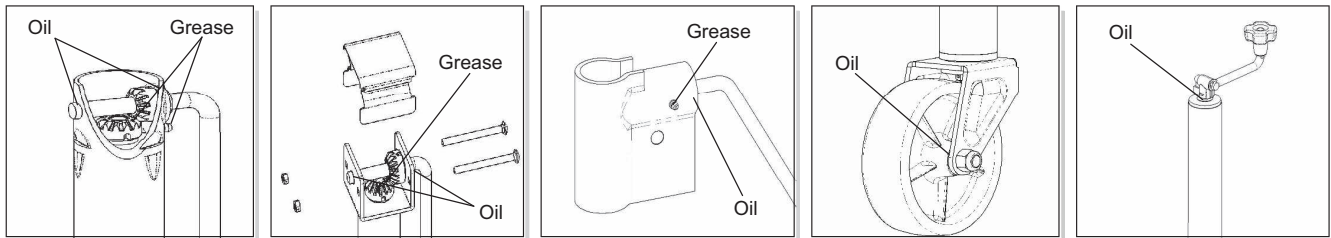

00243

TRAILER WHEEL BEARINGS

The trailer axles are equipped with a grease zerk fitting to allow lubrication of the wheel bearings without the need to disassemble the axle hub. To lubricate the axle bearings, remove the small rubber plug on the grease cap, attach a standard grease gun fitting to the grease zerk fitting and pump grease into the fitting until new grease is visible around the nozzle of the grease gun. Use only a high quality grease made specifically for lubrication of wheel bearings. Wipe any excess grease from the hub with a clean cloth and replace the rubber plug when finished. The minimum recommended lubrication is every 12 months or 12,000 miles (19,312 km). More frequent lubrication may be required under extremely dusty or damp operating conditions.

LOWER RADIATOR HOSE HEATER OPTION - USE AND MAINTENANCE

⚠ CAUTION

Improper use of the lower radiator hose heater could result in damage to the engine or personal injury. Do not modify the location of the lower radiator hose heater.

The following points should be followed when operating a unit equipped with a lower radiator hose heater.

- Ensure the cooling system is full of the proper mixture of water and engine coolant before each heater use.
- The heater is designed for all-night operation, however, 2-5 hours of heating just prior to starting is usually sufficient for proper engine starting.
- The unit must be level to maintain proper orientation of the heater while it is in operation.
- Use only an undamaged, outdoor rated, three-prong grounded 120VAC extension cord with a minimum amperage rating of 10A. Connect the cord to a properly grounded 120VAC, GFCI receptacle.
- Before starting the engine, unplug the extension cord from the power first, then unplug the heater cordset from the extension cord.

AC WIRING DIAGRAM - MLG8

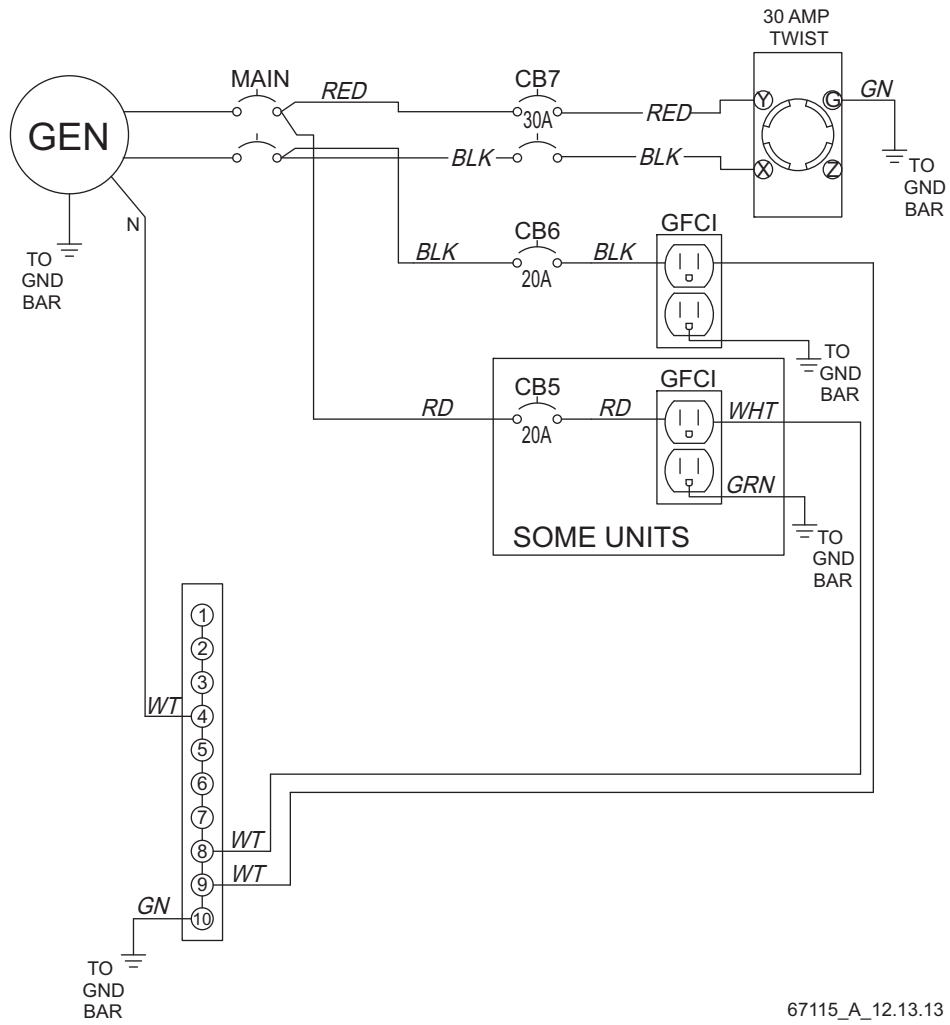

AC WIRING DIAGRAM - MLG15, MLG20, MLG20ICAN

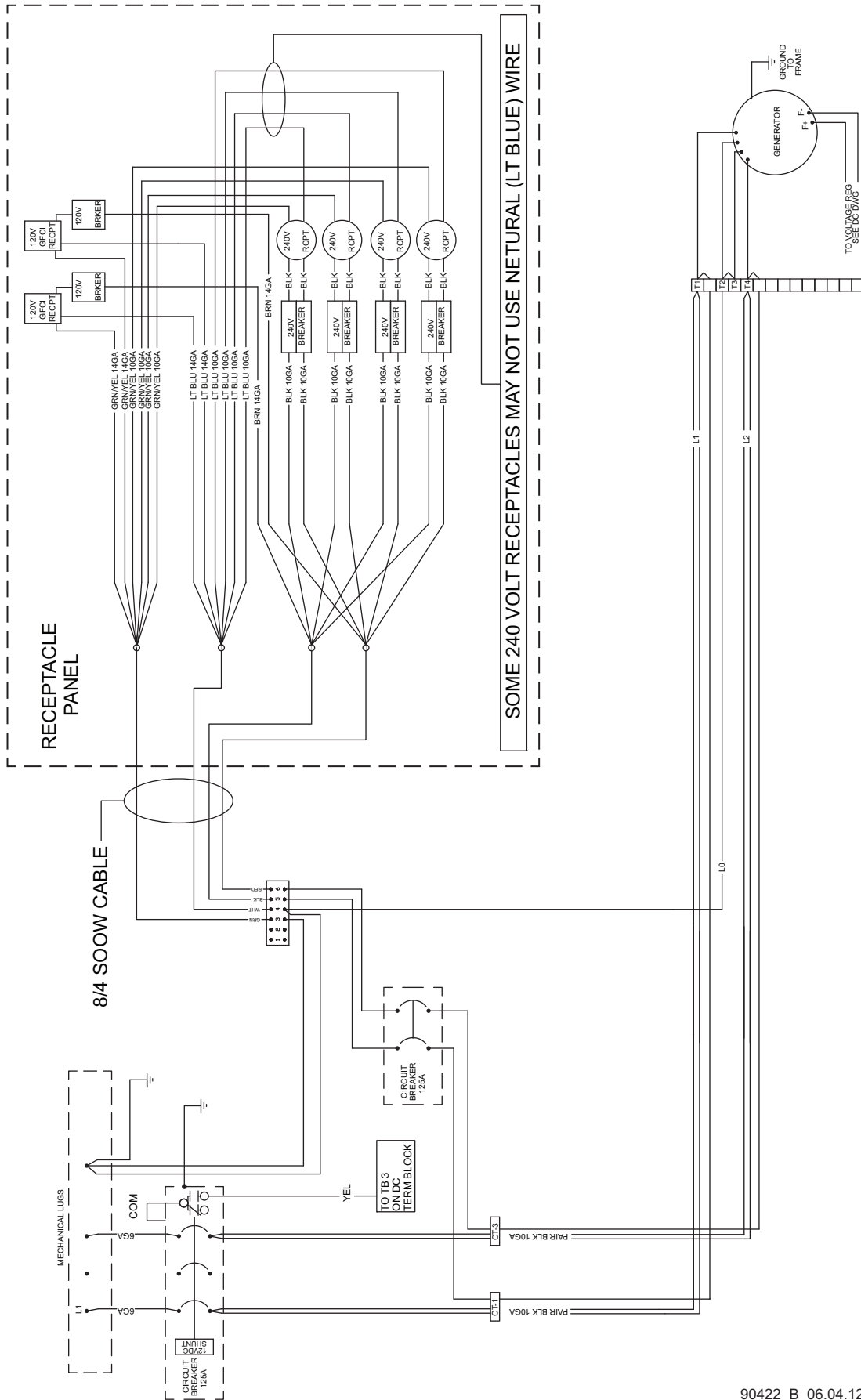

90422_B_06.04.12

AC WIRING DIAGRAM - RECEPTACLE PANEL

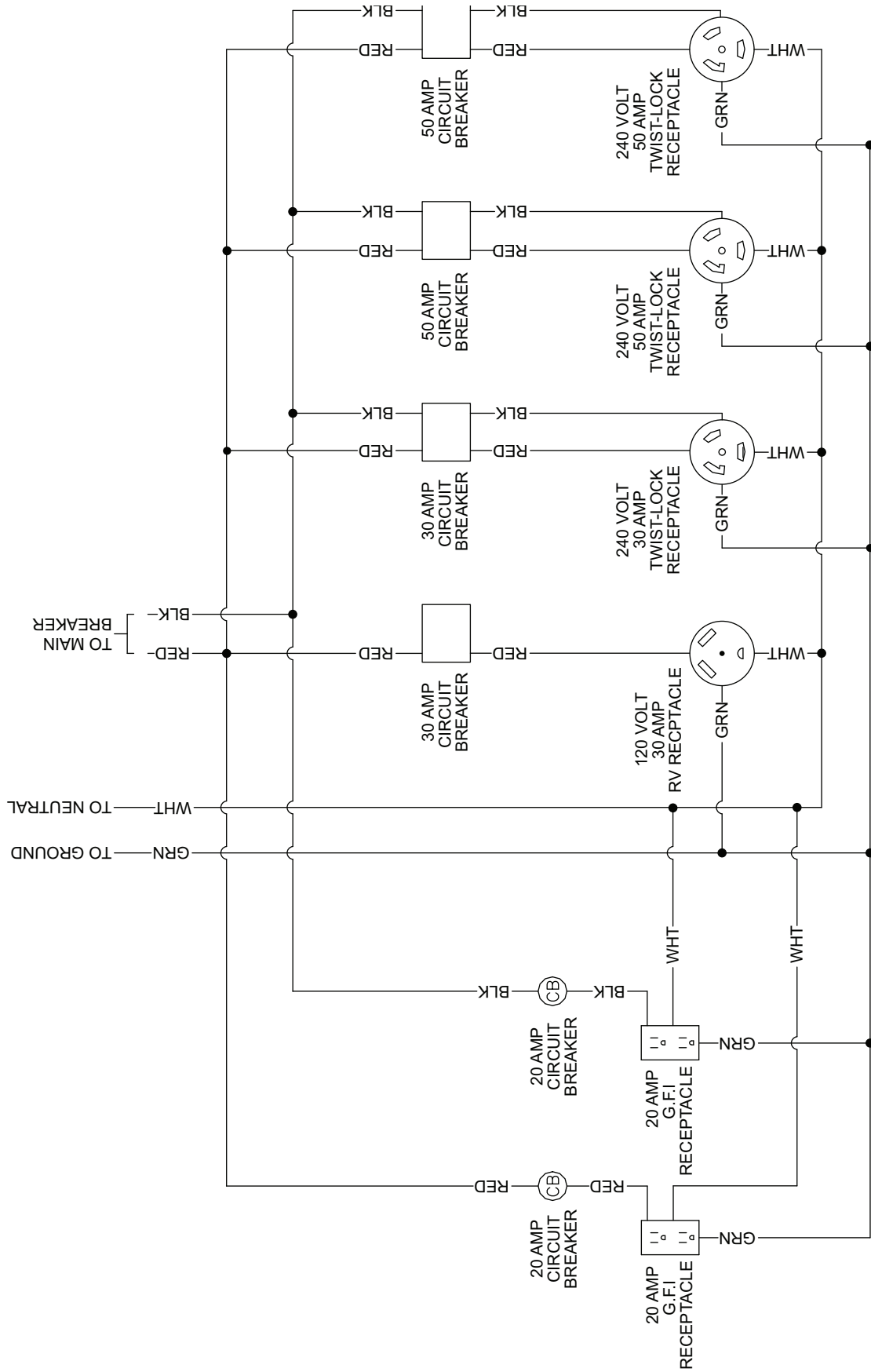

(2x5-20R, 1xTT-30, 1xL14-30R, 2x14-50)

90317_ORG_07.06.11

AC WIRING DIAGRAM - RECEPTACLE PANEL OPTIONS (1 OF 2)

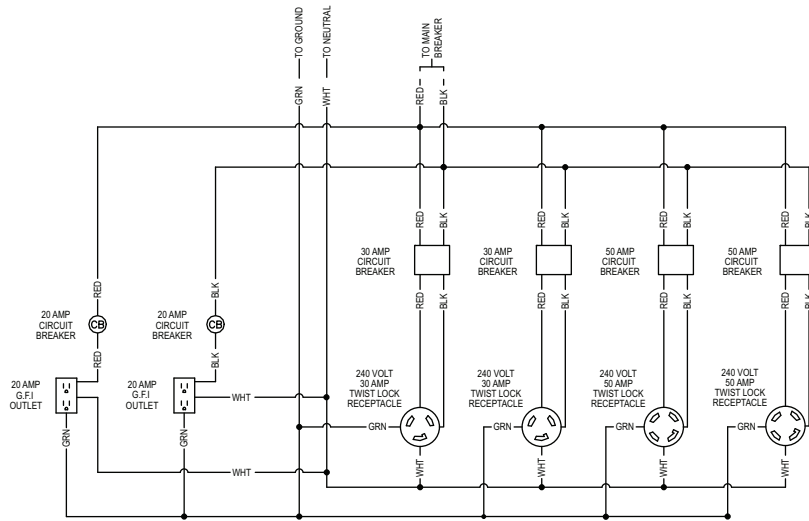

Receptacle Panel (2x5-20R, 2xL6-30R, 2xL14-50)

90315_ORG_10.14.11

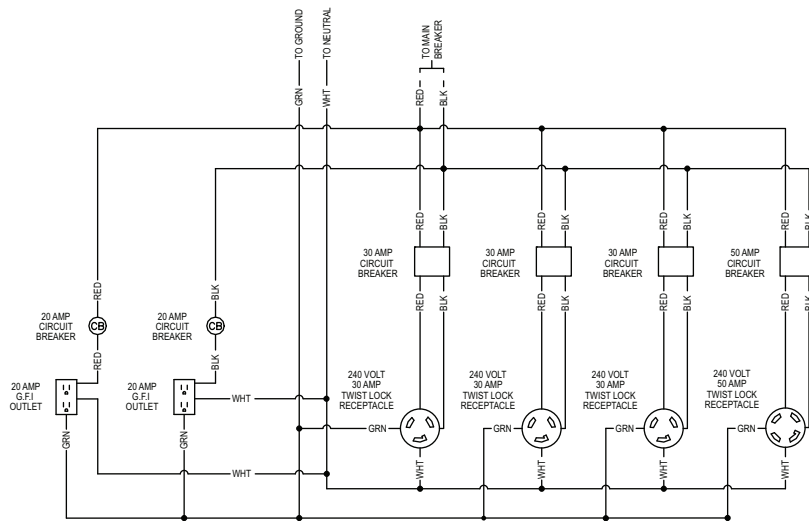

Receptacle Panel (2x5-20R, 3xL6-30R, 1xL14-50)

90318_ORG_07.06.11

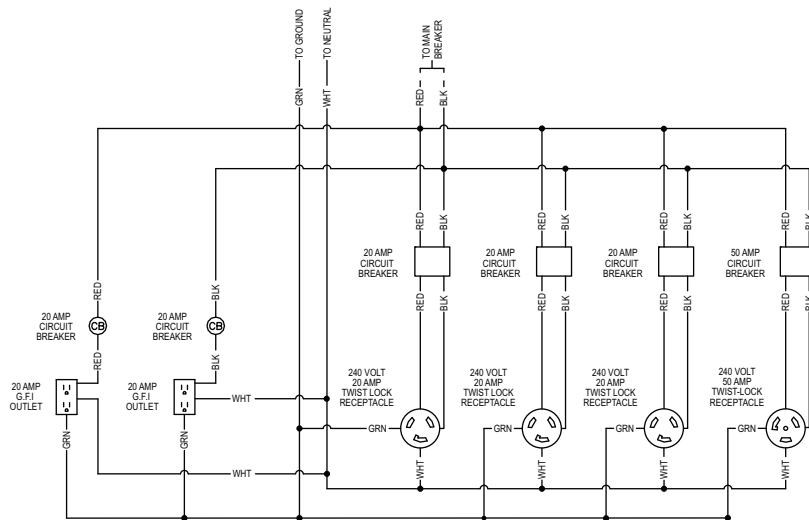

Receptacle Panel (2x5-20R, 3xL6-20R, 1x50A)

90319_ORG_07.06.11

AC WIRING DIAGRAM - RECEPTACLE PANEL OPTIONS (2 OF 2)

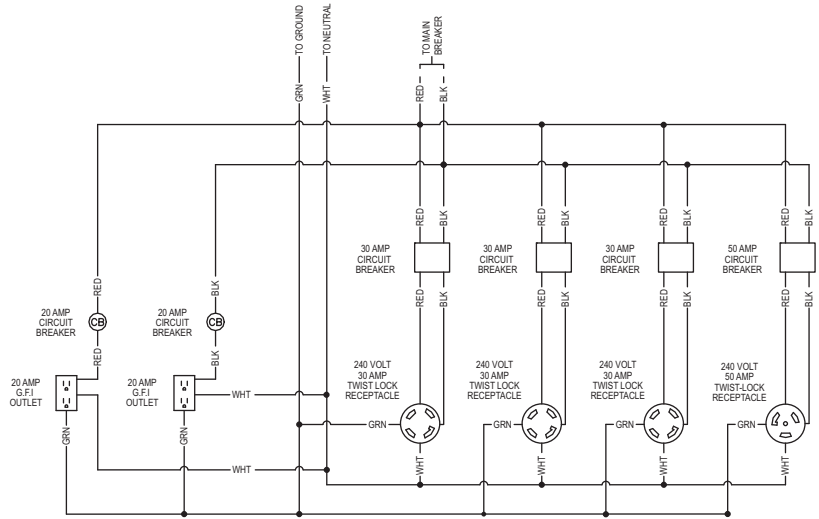

Receptacle Panel (2x5-20R, 3x14-30R, 1x50A)

90320_ORG_07.06.11

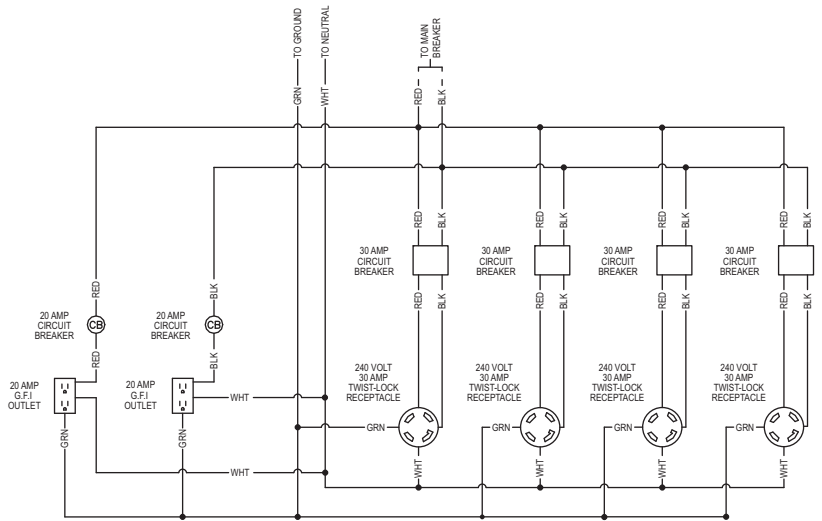

Receptacle Panel (2x5-20R, 4x14-30R)

90321_ORG_07.06.11

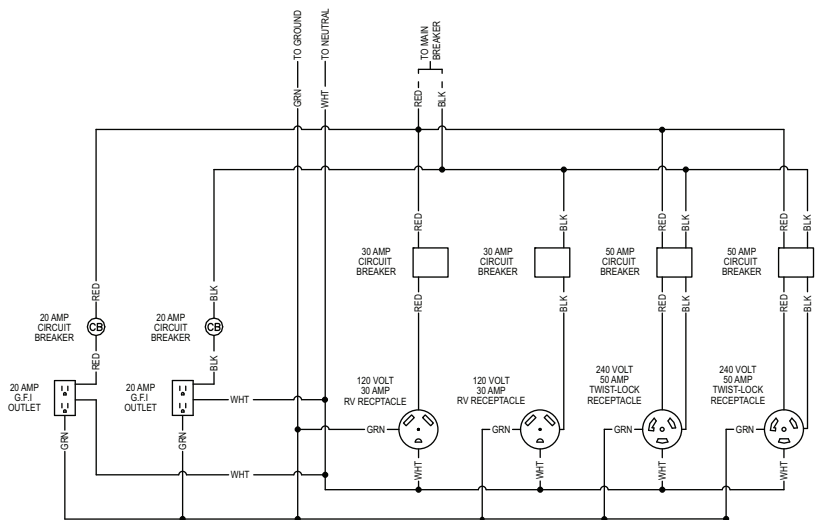

Receptacle Panel (2x5-20R, 2xTT-30, 2x14-50)

90355_ORG_07.06.11

DC WIRING DIAGRAM - MLG8

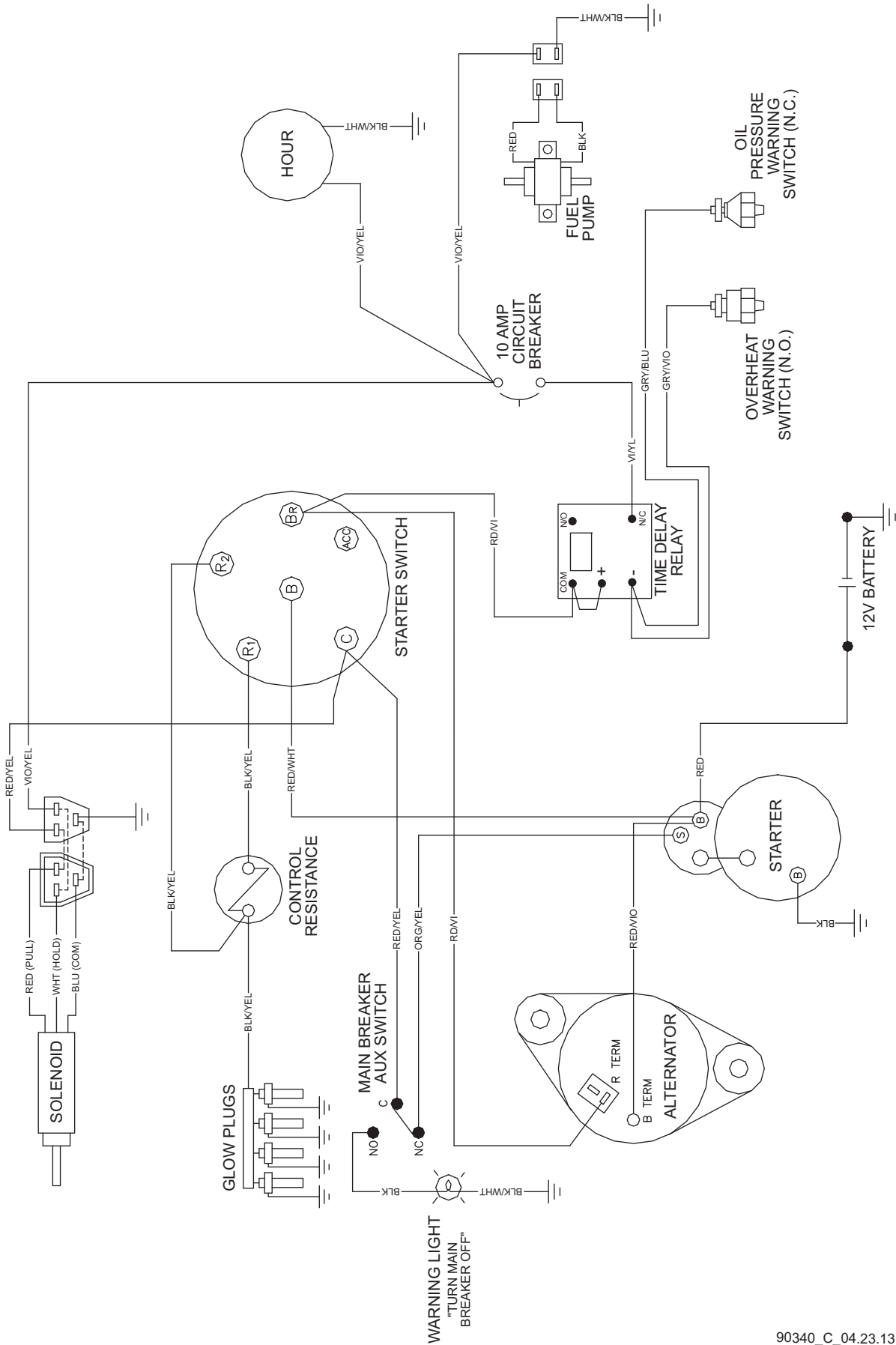

90340_C_04.23.13

DC WIRING DIAGRAM - MLG15, MLG20, MLG20CAN

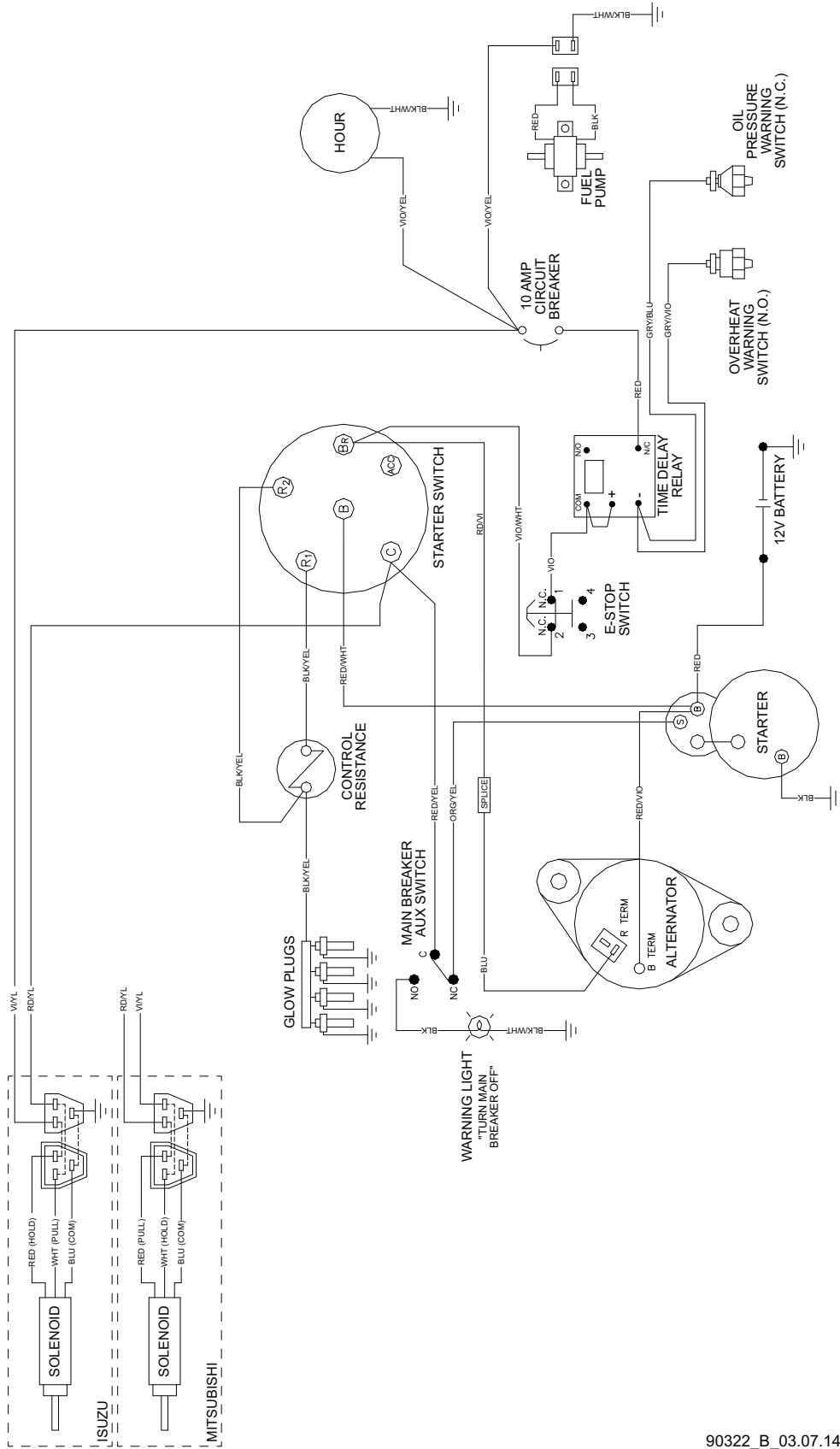

90322_B_03.07.14

DC WIRING DIAGRAMS FOR OPTIONAL EQUIPMENT

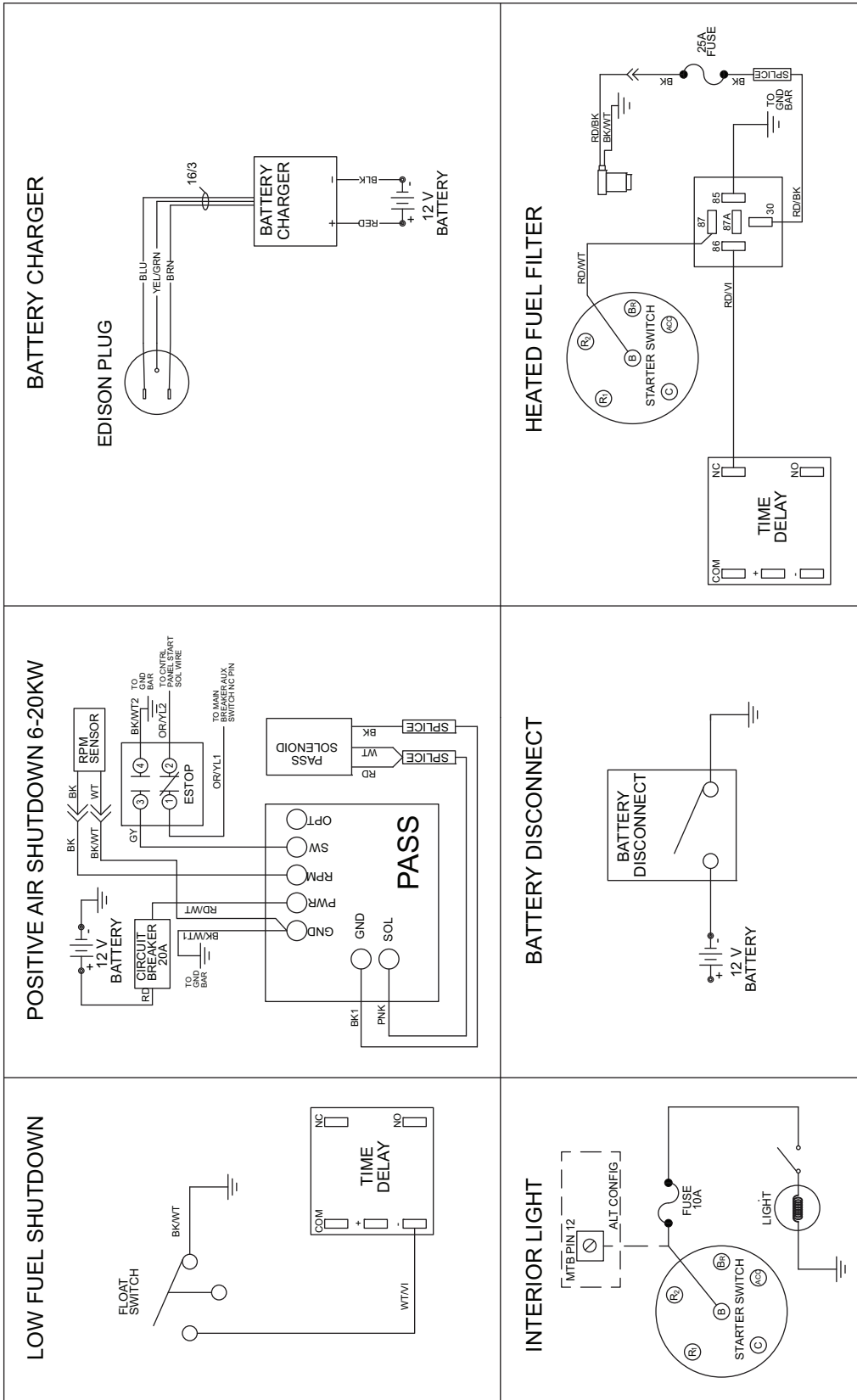

90323_K_06.04.14

TRAILER LIGHTS WIRING DIAGRAM

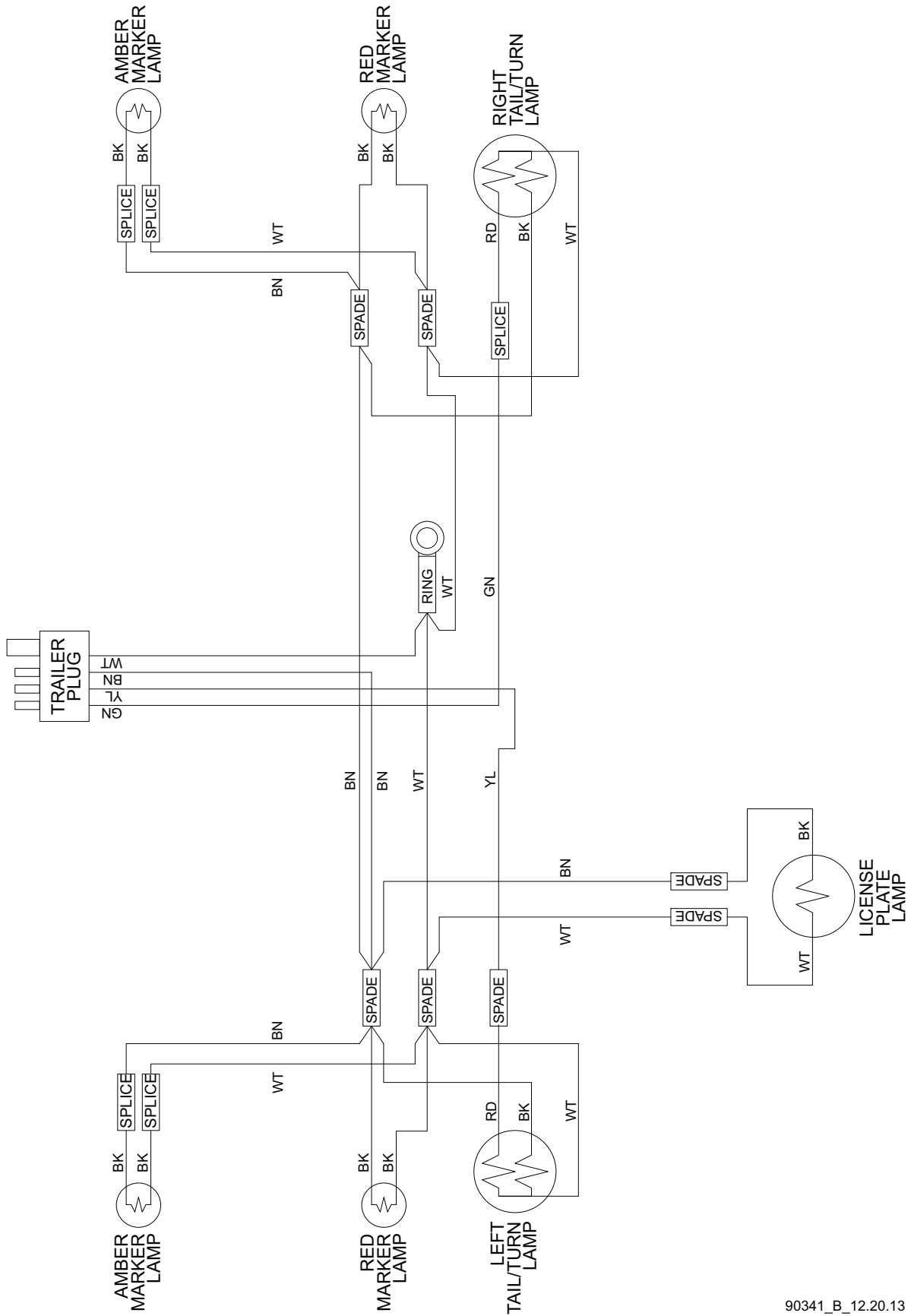

90341_B_12.20.13

REV: L
PART NO: 10289
11.21.14