

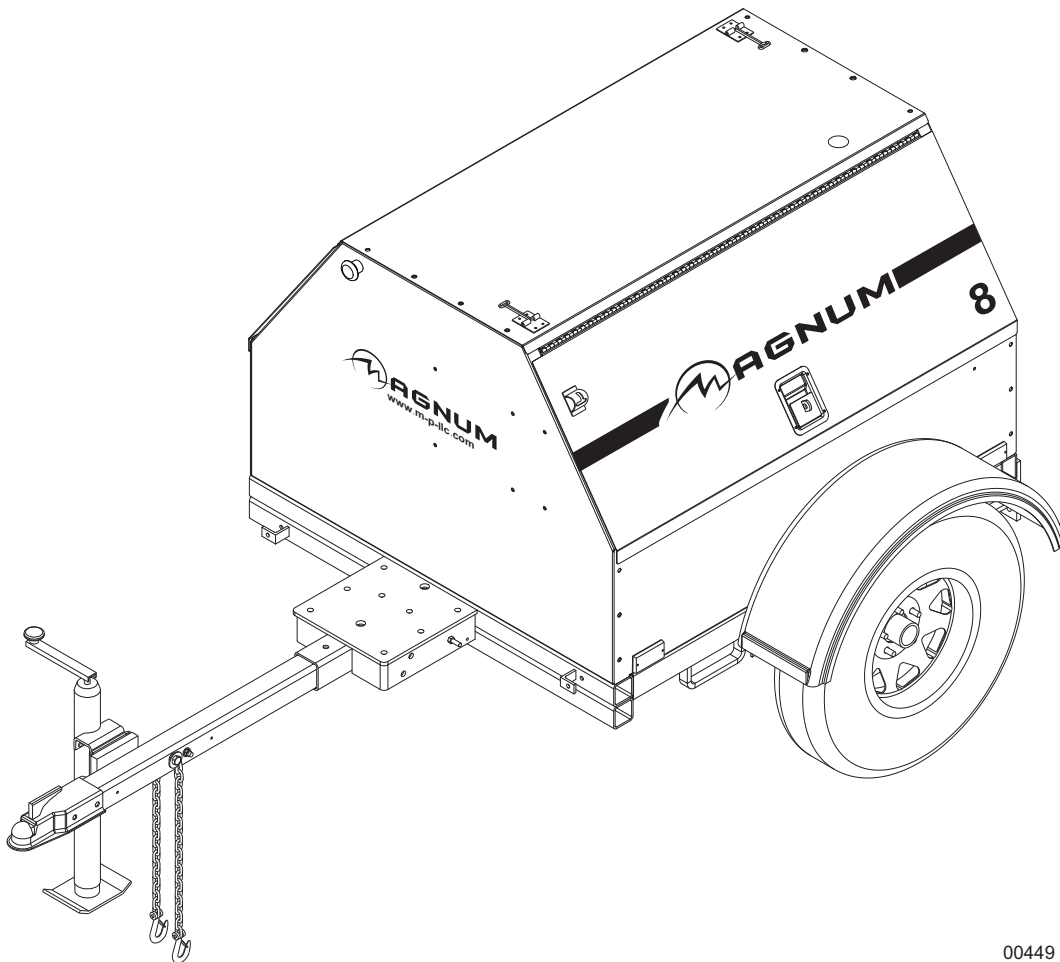

DIESEL GENERATOR MLG8K



00449

OPERATING MANUAL

Parts manuals available online! www.m-p-llc.com

INTRODUCTION

This manual provides information and procedures to safely operate and maintain the Magnum Power Products LLC unit. For your own safety and protection from physical injury, carefully read, understand, and observe the safety instructions described in this manual. Keep a copy of this manual with the unit at all times. Additional copies are available from Magnum Power Products LLC, or can be found at www.m-p-llc.com. *The information contained in this manual was based on machines in production at the time of publication. Magnum Power Products LLC reserves the right to change any portion of this information without notice.*

Read all of the manuals included with the unit. Each manual details specific information regarding items such as setup, use and service requirements. An engine operator's manual provides detailed operation and maintenance procedures for the engine. Additional copies of the engine operator's manual are available from the engine manufacturer.

DO NOT MODIFY or use this equipment for any application other than which it was designed for.

Magnum Power Products LLC recommends that a trained and licensed professional perform all electrical wiring and testing functions. Any wiring should be in compliance with the National Electrical Code (NEC), state and local codes and Occupational Safety and Health Association (OSHA) guidelines.

MAGNUM POWER PRODUCTS LLC

215 Power Drive • Berlin, WI 54923

U.S.A.

Phone: 920-361-4442

FAX: 920-361-4416

Toll Free: 1-800-926-9768

www.m-p-llc.com

For technical or parts **QUESTIONS**, please contact the Magnum Power Products LLC Customer Support or Technical Support team at 1-800-926-9768. Please have your serial number available.

To **ORDER SERVICE PARTS**, please contact the dealer from which you purchased the unit, or call Magnum Power Products LLC to locate a dealer in your area.

Engine Make: _____

Engine Serial Number: _____

Engine Model Number: _____

Generator Make: _____

Generator Model Number: _____

Generator Serial Number: _____

Unit Model Number: _____

Unit Serial Number: _____

▲ WARNING

CALIFORNIA PROPOSITION 65 WARNING: Diesel engine exhaust and some of its constituents are known to the state of California to cause cancer, birth defects and other reproductive harm.

TABLE OF CONTENTS

	Page
INTRODUCTION	2
SAFETY NOTES	4
OPERATING SAFETY	4
ENGINE SAFETY	5
SERVICE SAFETY	5
TOWING SAFETY	6
REPORTING TRAILER SAFETY DEFECTS	6
UNIT SERIAL NUMBER LOCATIONS	6
SAFETY SYMBOL SUMMARY	7
SPECIFICATIONS.....	8
MAIN CONTROL PANEL COMPONENTS	9
EXTERIOR COMPONENT LOCATIONS	10
GENERATOR START UP	11
PRESTART CHECKLIST	11
ENGINE STARTING AND OPERATION.....	11
WET STACKING	12
DERATING FOR ALTITUDE	12
AUTOMATIC SHUTDOWN	12
VOLTAGE REGULATION	12
EMERGENCY STOP SWITCH	12
SHUTTING DOWN THE GENERATOR.....	12
LIFTING THE TRAILER	13
TOWING THE TRAILER	13
JACK MAINTENANCE	14
TRAILER WHEEL BEARINGS	14
LOWER RADIATOR HOSE HEATER OPTION - USE AND MAINTENANCE.....	14
GENERAL MAINTENANCE	15
BASIC MAINTENANCE SCHEDULE - KUBOTA ENGINE	16
AC WIRING DIAGRAM	17
DC WIRING DIAGRAM	18
DC OPTIONS	19
TRAILER LIGHTS WIRING DIAGRAM	20
SERVICE LOG	21
NOTES	22

SAFETY NOTES



This is the safety alert symbol. It is used to alert you to potential personal injury hazards. Obey all safety messages that follow this symbol to avoid possible injury or death.

This manual contains DANGERS, WARNINGS, CAUTIONS, NOTICES and NOTES which must be followed to prevent the possibility of improper service, damage to the equipment, personal injury or death. The following formatting options will apply when calling the reader's attention to the DANGERS, WARNINGS, CAUTIONS, NOTICES and NOTES.

▲ DANGER

INDICATES A HAZARDOUS SITUATION WHICH, IF NOT AVOIDED, WILL RESULT IN DEATH OR SERIOUS INJURY.

▲ WARNING

Indicates a hazardous situation which, if not avoided, could result in death or serious injury.

▲ CAUTION

Indicates a hazardous situation which, if not avoided, may result in minor or moderate injury.

NOTICE

Indicates a hazardous situation which, if not avoided, may result in property or equipment damage.

Note: Notes contain additional information important to a procedure and will be found within the regular text body of this manual.

OPERATING SAFETY



Before using the unit, be sure to read and understand all of the instructions. This equipment was designed for specific applications; **DO NOT** modify or use this equipment for any application other than which it was designed for. Equipment operated improperly or by untrained personnel can be dangerous.

Read the operating instructions and familiarize yourself with the location and proper use of all instruments and controls. Inexperienced operators should receive instruction from someone familiar with the equipment before being allowed to operate or set up the unit. The following points should be practiced at all times:

- The area immediately surrounding the unit should be dry, clean, and free of debris.
- Position and operate unit on a firm, level surface.
- **NEVER** start a unit in need of repair.
- Make certain the unit is securely fastened to a good earthen ground before use. Follow any local, state, or National Electric Code (NEC) guidelines.
- **NEVER** operate the unit on a combustible surface.
- **NEVER** operate a unit while tired, distracted, or under the influence of drugs or alcohol.
- Make sure all lifting devices are attached securely and have enough weight-bearing capacity to hold the equipment safely. Always remain aware of the position of other people around you when lifting the equipment.
- **NEVER** operate the unit if any of the following conditions exist:
 1. Noticeable change in engine speed.
 2. Loss of electrical output.
 3. Equipment connected to the generator overheats.
 4. Sparking occurs.
 5. Engine misfires or there is excessive engine/generator vibration.
 6. Protective covers are loose or missing.

7. If the ambient air temperature is above 120°F (49°C).

ENGINE SAFETY



Internal combustion engines present special hazards during operation and fueling. Failure to follow the safety guidelines described below could result in severe injury or death. Read and follow all safety warnings described in the engine operator's manual. A copy of this manual was supplied with the unit when it was shipped from the factory.

- **DO NOT** run engine indoors or in an area with poor ventilation. Diesel engine exhaust contains carbon monoxide, a deadly, odorless and colorless gas which, if inhaled, can cause nausea, fainting or death. Only use this unit outside and away from windows, doors, and ventilation equipment.
- **DO NOT** fill fuel tank near an open flame, while smoking, or while engine is running. **DO NOT** fill tank in an enclosed area with poor ventilation.
- **DO NOT** operate with the fuel tank cap loose or missing.
- **DO NOT** touch or lean against hot exhaust pipes or engine cylinders.
- **DO NOT** clean air filter with gasoline or other types of low flash point solvents.
- **DO NOT** remove engine coolant cap while engine is hot.
- **DO NOT** operate the unit without a functional exhaust system. Prolonged exposure to sound levels in excess of 85 dB(A) can cause permanent hearing loss. Wear hearing protection when working around a running engine.
- Keep all body parts and loose clothing away from moving parts on the unit.
- Keep area around exhaust pipes and air ducts free of debris to reduce the chance of an accidental fire.
- Batteries contain sulfuric acid which can cause severe injury or death. Sulfuric acid can cause eye damage, burn flesh or eat holes in clothing. Protective eye wear and clothing are necessary when working on or around the battery. Always disconnect the negative (-) battery cable from the corresponding terminal before performing any service on the engine or other components.

SERVICE SAFETY



This unit uses high voltage circuits capable of causing serious injury or death. Only a qualified electrician should troubleshoot or repair electrical problems occurring in this equipment.

- Before servicing the generator, make sure the engine start switch is turned to "OFF", circuit breakers are open (off) and the negative terminal on the battery is disconnected. Open the main circuit breaker before disconnecting battery cables. **NEVER** perform even routine service (oil/filter changes, cleaning, etc.) unless all electrical components are shut down.
- **NEVER** allow water to accumulate around the base of the generator. If water is present, **DO NOT** service.
- **NEVER** service electrical components if clothing or skin is wet. If the unit is stored outside, check the engine and generator for any moisture and dry the unit before use.
- **NEVER** wash the unit with a power washer or high pressure hose.
- **NEVER** start the unit under load. The circuit breakers must be in the "OFF" position when starting the unit.
- **ALWAYS** disconnect the negative (-) battery cable from the corresponding terminal before performing any service on the engine, generator or any other components. Remove the negative (-) battery cable from the corresponding terminal if the unit is to be stored or transported.
- Replace all guards and safety devices immediately after servicing
- **ALWAYS** connect the unit to a good earthen ground before use. Follow any local, state or National Electrical Code (NEC) guidelines.

TOWING SAFETY



Towing a trailer requires care. Both the trailer and vehicle must be in good condition and securely fastened to each other to reduce the possibility of an accident. Some states require that large trailers be registered and licensed. Contact your local Department of Transportation office to check on license requirements for your particular unit.

- Check that the hitch and coupling on the towing vehicle are rated equal to, or greater than, the trailer's Gross Vehicle Weight Rating (GVWR).
- Check tires on trailer for tread wear, inflation, and condition.
- **NEVER** tow trailer using defective parts. Inspect hitch and coupling for wear or damage.
- Make sure the trailer hitch and the coupling are compatible. Make sure the coupling is securely fastened to the vehicle.
- Connect safety chains in a crossing pattern under the tongue and **ATTACH THE BREAKAWAY CABLE TO THE REAR BUMPER OF THE TOWING VEHICLE**. Do not attach the cable to the trailer hitch.
- Make sure directional and brake lights on the trailer are connected and working properly.
- Check that all lug nuts holding wheels on are tight and that none are missing.
- Maximum recommended speed for highway towing is 45 mph (72 km/h). Recommended off-road towing speed is not to exceed 10 mph (16 km/h) or less, depending on terrain.
- When towing, maintain extra space between vehicles and avoid soft shoulders, curbs and sudden lane changes. If you have not pulled a trailer before, practice turning, stopping, and backing up in an area away from heavy traffic.

REPORTING TRAILER SAFETY DEFECTS

If you believe your trailer has a defect which could cause a crash or could cause injury or death, you should immediately inform the National Highway Traffic Safety Administration (NHTSA) in addition to notifying Magnum Power Products LLC.

If NHTSA receives similar complaints, it may open an investigation; and if it finds that a safety defect exists in a group of vehicles, it may order a recall and remedy campaign. However, NHTSA cannot become involved in an individual problem between you, your dealer, or Magnum Power Products LLC.

To contact NHTSA, you may either call the Auto Safety Hotline toll-free at 1-888-327-4236 (TTY:1-800-424-9153), go to <http://www.safercar.gov>; or write to:

Administrator
NHTSA
1200 New Jersey Avenue S.E.
Washington, DC 20590

You can also obtain other information about motor vehicle safety from <http://www.safercar.gov>.

UNIT SERIAL NUMBER LOCATIONS

Refer to the illustration to locate the unit ID tag and Vehicle Identification Number (VIN) tag on the unit. Important information, such as the unit serial number, model number, VIN and tire loading information are found on these tags. Record the information from these tags so it is available if the tags are lost or damaged. When ordering parts or

requesting assistance, you may be asked to provide this information.

Unit ID Tag

Manufactured by
MAGNUM POWER PRODUCTS LLC
 A wholly owned subsidiary of
 Generac Power Systems, Inc.
 210 Power Drive • Berlin, WI 54923
 1-800-526-5768

Model: _____ Serial Number: _____

City: _____ State: _____

Rated WT (lb/kg): _____

KVA: _____ 3 ph, 1.0PF 3 ph, .8PF 3 ph, 1.0PF

V: _____

A: _____

RATING: _____

FOR ELECTRICAL
 CONSULT WITH
 YOUR LOCAL
 ELECTRICIAN

Located on
inside of panel.

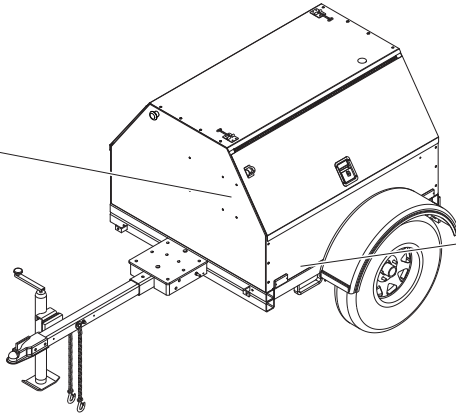

VIN Tag

MANUFACTURED BY/REGULATED BY: Magnum Power Products LLC DATE: 000000
 COUNTRY OF ORIGIN: 0000 (0000.00) COLLECTIVE PRODUCT CODE: 000000
 PRODUCT ID: _____ TYPE: _____ TRAILER/UNIT: _____ GROSS A WEIGHT: 0000000000000000

DATE: _____

WEIGHT AND LOADING INFORMATION
 PERMITTED TO EXCEED
 THE WEIGHT OF CARGO UNLESS NOTED OTHERWISE. CONSULT
 YOUR LOCAL DEPARTMENT OF TRANSPORTATION FOR REGULATIONS.

DO NOT EXCEED
 ADDITIONAL
 WEIGHTS
 UNLESS
 SPECIFICALLY
 NOTED
 OTHERWISE

000000000000000000000000 MODEL: XXX000 TYPE: TRAILER

00245

SAFETY SYMBOL SUMMARY

This equipment has been supplied with numerous safety and operating decals. These decals provide important operating instructions and warn of dangers and hazards. Replace any missing or hard to read decals and use care when washing or cleaning the unit. Decal placement and part numbers can be found in the parts manual. Below is a summary of the intended meanings for the symbols used on the decals.

	Safety alert symbol; used to alert you to potential personal injury hazards.		Asphyxiation hazard; operate in well ventilated area.
	Hot surface(s) nearby.		Dangerous voltage may be present.
	Belt/entanglement hazard; keep body parts clear of this area.		Anchor/tie down point.
	Fan hazard; keep body parts clear of this area.		Unit electrical ground.
	Stop engine before fueling.		Use clean diesel fuel only.
	Fire/explosion hazard; keep open flames away from unit.		Burn/scald hazard; pressurized steam.
	Read and understand the supplied operator's manual before operating unit.		Lift here only.
	Remove negative battery cable before performing any service on unit.		

00246

SPECIFICATIONS

MAGNUM MODEL

MLG8K

Engine

Make/Brand.....	Kubota
Model	D1105-E3BG
EPA Tier	4f
Horsepower - prime hp (kW)	13.5 (10.1)
Horsepower - standby hp (kW)	15.4 (11.5)
Operating Speed rpm	1800
Displacement in³ (L)	68.53 (1.12)
Cylinders - qty	3
Fuel Consumption - 100% prime gph (Lph)	0.70 (2.65)
Battery Type.....	Group 24
Battery Voltage (Quantity per Unit)	12V (1)
Battery Rating	440 CCA

Generator

Make/Brand.....	Marathon Electric
Model	332CSA/B3018
Type, Insulation	Brushless, F

Generator Set (Engine/Generator)

3Ø - Standby kW (kVA)	N/A
Amps - 3Ø Standby 480V (208V) A	N/A
3Ø - Prime kW (kVA)	N/A
Amps - 3Ø Prime 480V (208V) A	N/A
1Ø - Standby kW (kVA)	9.0 (9.0)
Amps - 1Ø Standby - 240V A	37
1Ø - Prime kW (kVA)	8.1 (8.1)
Amps - 1Ø Prime - 240V A	33
Frequency Hz	60
Power Factor.....	1 (1Ø)
Sound dB(A) 23 ft @ prime	70

Dimensions (L x W x H) in (m)	105 x 68 x 56 (2.67 x 1.73 x 1.42)
--	---------------------------------------

Weights

Dry Weight lbs (kg)	1030 (467)
Operating Weight lbs (kg)	1250 (567)

Capacities

Fuel Tank Volume gal (L)	30 (114)
Usable Fuel Volume gal (L)	30 (114)
Maximum Run Time hrs	48

AC Distribution

Circuit Breaker Size	40
Voltage Selection	N/A
Voltage Regulation	+/- 1%
Voltages Available 1Ø.....	120, 240
Voltages Available 3Ø.....	N/A

Trailer

Number of Axles	1
Capacity - Axle Rating lbs (kg)	2200 (998)
Tire Size in	13
Brakes.....	N/A
Hitch - Standard	2" Ball
Maximum Tire Pressure psi	50

Specifications are subject to change without notice.

MAIN CONTROL PANEL COMPONENTS

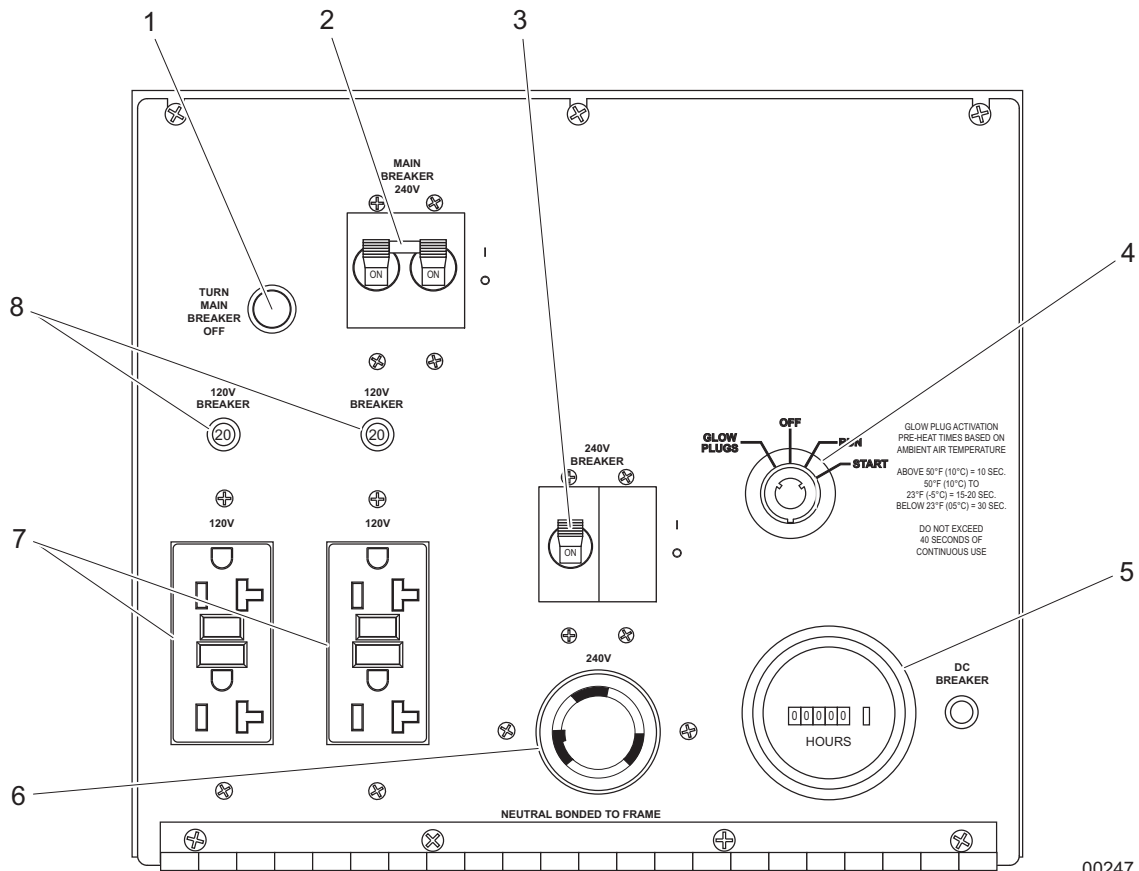

1. **CIRCUIT BREAKER INDICATOR LIGHT:** The red light indicates that the main circuit breaker must be opened (switched off) before starting the engine.
2. **MAIN CIRCUIT BREAKER:** This breaker will disconnect power to the receptacle panel.
3. **CIRCUIT BREAKER (30A):** This breaker is supplied for the standard 240V twist-lock receptacle.
4. **ENGINE START SWITCH:** Keyed switch operates the glow plugs and starts and stops the engine.
5. **ENGINE HOUR METER:** Keeps track of engine hours for service.
6. **240V RECEPTACLE:** This twist-lock receptacle supplies power for accessories connected to the generator when the engine is running and the main circuit breaker is switched to the "ON" position.
7. **120V GFCI RECEPTACLES:** These receptacles supply power for accessories connected to the generator when the engine is running and the main circuit breaker is switched to the "ON" position.
8. **CIRCUIT BREAKERS (20A):** These breakers are supplied for the standard 120V GFCI receptacles.

EXTERIOR COMPONENT LOCATIONS

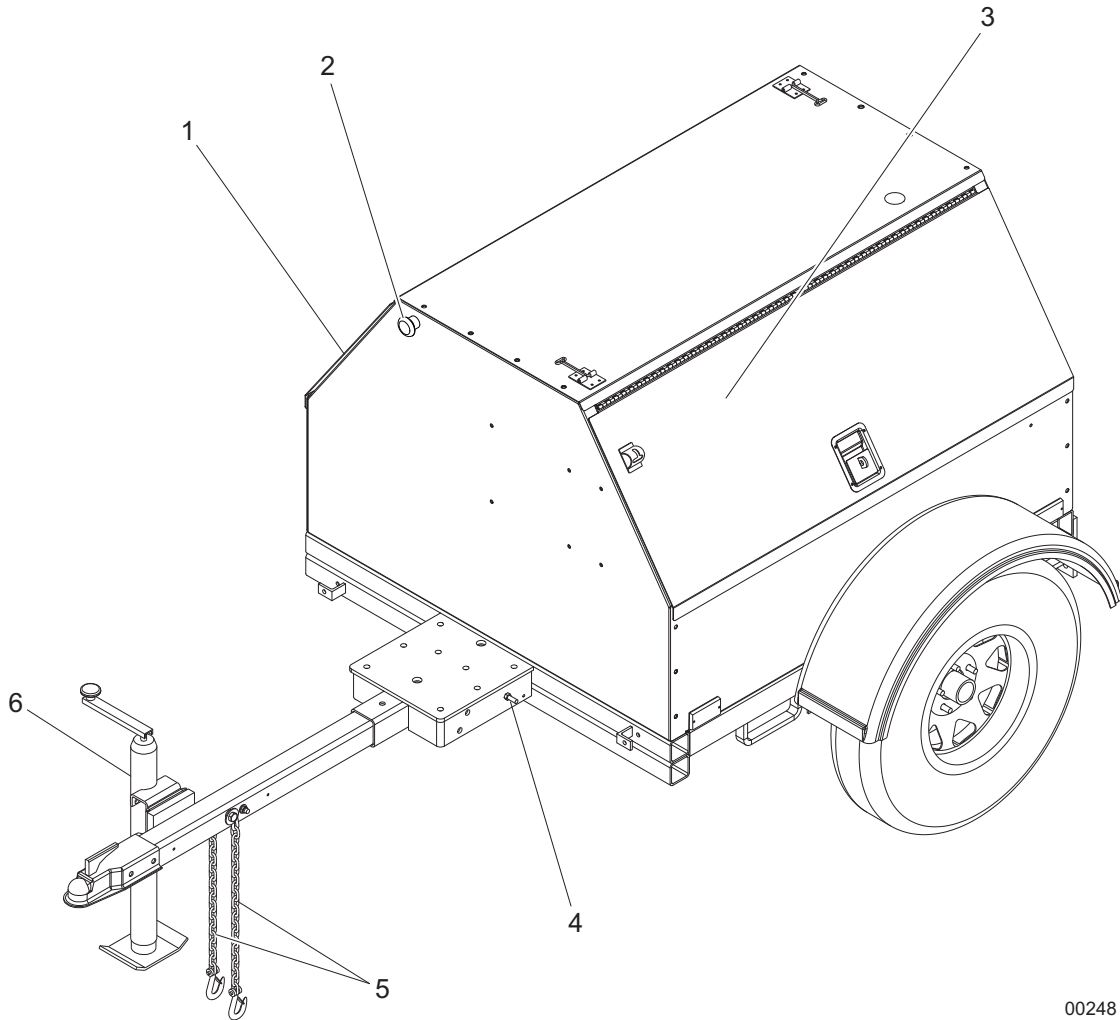

00248

1. **FUEL FILLER LOCATION (under door):** Use clean **DIESEL FUEL ONLY**.
2. **EMERGENCY STOP SWITCH:** For emergency shutdown; stops engine and trips main circuit breaker.
3. **CONTROL PANEL LOCATION (under door):** Refer to [page 9](#).
4. **GROUND STUD:** For grounding generator and equipment connected to the unit.
5. **SAFETY CHAINS:** Used in a crossing pattern under the tongue to attach unit to towing vehicle.
6. **TONGUE JACK:** Used to level generator before starting.

GENERATOR START UP

Before starting the generator, carefully read the prestart checklist. Make sure that all of the items are checked before trying to start the generator. This check list applies for both manual and remote starting of the generator.

PRESTART CHECKLIST

- Make sure the engine start switch is in the “OFF/O” position.
- Make sure the circuit breakers (main and equipment) are switched “OFF/O”.
- Check that the generator is properly grounded to a good earthen ground per local and NEC regulations.
- Make sure the generator is sitting level.
- Check for any water inside, on, or near the generator. Dry the unit before starting.
- Check engine oil level, engine coolant level and engine battery connections.
- Check engine fan belt tension and condition.
- Check engine fan belt guard.
- Check engine exhaust system for loose or rusted components.
- Are any of the generator covers loose or missing?
- Are all preventive maintenance procedures up to date?
- Check that the battery disconnect switch is on, if equipped.

ENGINE STARTING AND OPERATION

1. Check engine oil, fuel and coolant levels.

Note: If the engine was run out of fuel or the fuel tank was drained, it may be necessary to bleed the fuel lines. Refer to the engine operator’s manual supplied with the unit.

2. Check the condition of the electrical cord on the inside of the unit.
3. Check that the main circuit breaker and individual circuit breakers for each of the outlets are in the “OFF/O” position.

Note: When the red “TURN MAIN BREAKER OFF” light is illuminated, the main circuit breaker must be turned “OFF/O”.

4. Turn the key on the engine start switch to the left “GLOW PLUG” position and hold the key in place for five seconds. Turn the key to the right “START” position and hold it until the engine cranks and starts running. Release the key, it will move to the “RUN” position.

Note: Refer to the engine operator’s manual for cold weather glow plug intervals.

ACTIVATE GLOW PLUGS

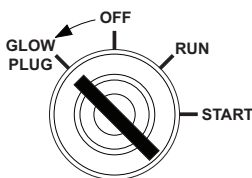

CRANK ENGINE TO START

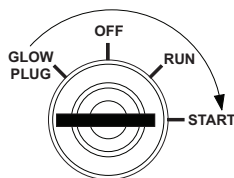

RELEASE KEY

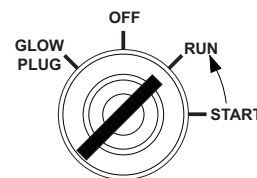

00203

NOTICE

Do not crank the engine longer than 10 seconds at a time. If the engine does not start, wait 30 seconds to allow the starter motor to cool and then repeat the starting procedure. Excessive cranking will cause damage to the starter.

Note: If oil pressure is not obtained within 15 seconds after the key is switched to the “RUN” position, the low-oil automatic shutdown will turn off the fuel supply, stopping the engine. Check the oil level and turn the key to the “OFF” position to reset the oil pressure timer before attempting to restart the engine.

5. Once the engine is running, allow it to reach normal operating temperature before switching on any loads.

WET STACKING

The unit is powered by a diesel engine. Diesel engines are susceptible to wet stacking if lightly loaded. Wet stacking occurs when an engine is run at less than 30% of its full load capacity, causing unburned fuel to accumulate in the exhaust system. Wet stacking can be detected by continuous black exhaust when the unit is under a constant load. It can also cause fouling of injectors and buildup on engine valves. Diesel engines operate properly when applied loads are between 30% and 100% capacity. Appropriate generator sizing is determined by the anticipated load. If the unit is in a wet stack condition, load the unit heavily for five hours or until the exhaust is clear.

DERATING FOR ALTITUDE

All units are subject to derating for altitude and temperature; this will reduce the available power for operating tools and accessories connected to the control panel. Typical reductions in performance are 2-4% for every 1000 ft. (305 m) of elevation and 1% per 10°F (5.6°C) increase in ambient air temperature over 72°F (22°C).

AUTOMATIC SHUTDOWN

This unit is equipped with a low oil pressure and high coolant temperature auto-shutdown system. This system will automatically shut off the fuel supply to stop the engine if oil pressure drops too low or if the engine exceeds normal operating temperature. Return the engine start switch to the “OFF” position to reset the unit after you have determined the cause of the shutdown.

VOLTAGE REGULATION

The electronic voltage regulator controls the output of the generator by regulating the DC voltage into the exciter field. The regulator has three screwdriver adjustable potentiometers that may be adjusted for voltage, stability and under frequency (U/F). The voltage regulator on your unit is adjusted before shipment from the factory. Contact Magnum Power Products LLC for additional information before attempting to adjust the voltage regulator.

EMERGENCY STOP SWITCH

The unit is equipped with one Emergency Stop switch. For location of the Emergency Stop switch, refer to [“Exterior Component Locations” on page 10](#). The red switch is clearly labeled “EMERGENCY STOP”. The switch can be accessed and activated with all doors closed and locked.

Activate the Emergency Stop switch by pushing the red button in until it locks down. This will trip the main circuit breaker which will open the contact, disconnecting the load to the connection lugs. This will also open the fuel circuit, shutting down the engine.

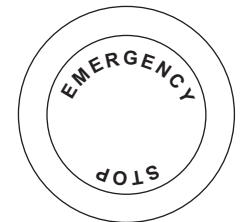

00230

The switch will remain closed until it is pulled out.

NOTICE

Use the Emergency Stop switch only when the unit must be shut down immediately. For any other shut down, refer to [“Shutting Down The Generator” on page 12](#).

SHUTTING DOWN THE GENERATOR

When you have finished using the generator, proceed with shut down as follows:

1. Remove any loads from the main control panel receptacles.
2. Switch the individual circuit breakers for each receptacle to the “OFF/O” position.
3. Switch the main circuit breaker to the “OFF/O” position.
4. Turn the engine start switch to the “OFF” position.

NOTICE

Always switch all circuit breakers to the "OFF/O" position to prevent starting the generator under load.

Note: For extended storage time, disconnect the battery. Refer to the engine operator's manual for extended storage requirements.

LIFTING THE TRAILER

1. Make sure the equipment being used to lift the generator has sufficient capacity. Refer to "Specifications" on page 8 for approximate weights.
2. Always remain aware of the position of other people and objects around you as you move the unit.
3. Use the forklift pockets (2) & (3) with care. Approach the unit as perpendicular as possible to avoid any damage to the unit. Make sure any obstructions are clear of the forklift tines before lifting.

Note: When lifting the unit using the optional lift structure, attach any slings, chains or hooks directly to the central lift point. The lift point (1) is located between the two upper forklift pockets (2).

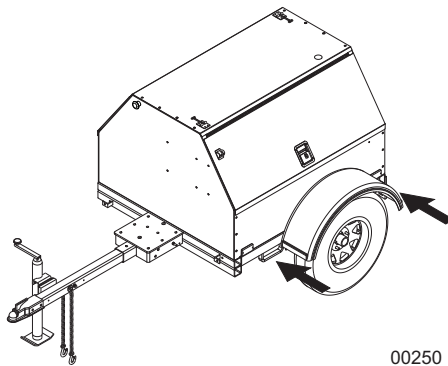

Trailer with Standard Forklift Pockets

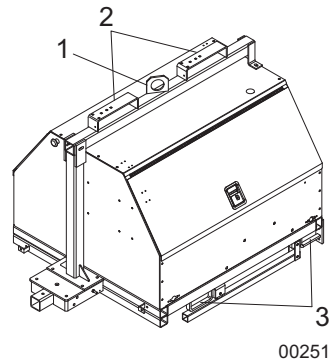

Trailer with Optional Lift Structure

TOWING THE TRAILER

1. Use the jack to raise or lower the trailer onto the hitch of the towing vehicle. Lock the hitch coupling and attach the safety chains or cables to the vehicle. Release the jack locking pin and rotate the jack into the travel position. Make sure the locking pin snaps into place. To ensure proper operation of the jack, lube the grease fitting located on the leveling jack on the tongue.
2. Connect any trailer wiring to the tow vehicle. Check for proper operation of the stop and signal lights.
3. Make sure the doors are properly latched.
4. Check for proper inflation of the trailer tires. The maximum tire pressure is 50 psi (345 kPa).
5. Check the wheel lugs. Tighten or replace any lugs that are loose or missing. If a tire has been removed for axle service or replaced, tighten the lugs in the order shown to the following specifications:
 - A. Start all lug nuts by hand.
 - B. First pass tighten to 20-25 ft-lbs (27-33 Nm).
 - C. Second pass tighten to 50-60 ft-lbs (67-81 Nm).
 - D. Third pass tighten to 90-120 ft-lbs (122-162 Nm).

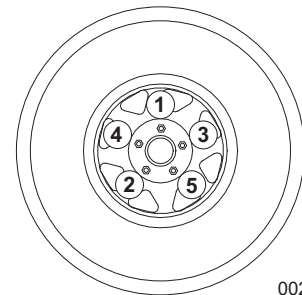

Note: After the first road use, re-torque the lug nuts in sequence, as shown.

6. Maximum recommended speed for highway towing is 45 mph (72 km/h). Recommended off-road towing speed is not to exceed 10 mph (16 km/h) or less, depending on terrain.

JACK MAINTENANCE

The following procedures should be performed at least annually.

SIDE-WIND MODELS

- The internal gearing and bushings of the jack must be kept lubricated. Apply a small amount of automotive grease to the internal gearing by removing the jack cover, or if equipped, use a needle nose applicator or standard grease gun on the lubrication point found on the side of the jack near the crank. Rotate the jack handle to distribute the grease evenly.
- A lightweight oil must be applied to the handle unit at both sides of the tube.
- If equipped, the axle bolt and nut assembly of the caster wheel must also be lubricated with the same light weight oil.

TOP-WIND MODELS

- Apply a lightweight oil to the screw stem.

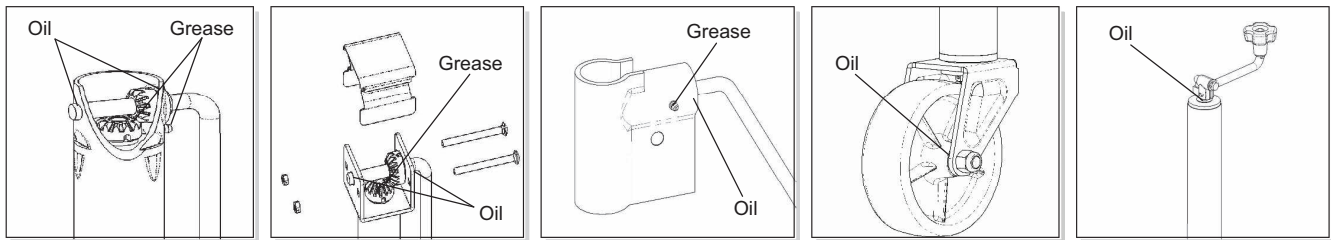

00243

TRAILER WHEEL BEARINGS

The trailer axles are equipped with a grease zerk fitting to allow lubrication of the wheel bearings without the need to disassemble the axle hub. To lubricate the axle bearings, remove the small rubber plug on the grease cap, attach a standard grease gun fitting to the grease zerk fitting and pump grease into the fitting until new grease is visible around the nozzle of the grease gun. Use only a high quality grease made specifically for lubrication of wheel bearings. Wipe any excess grease from the hub with a clean cloth and replace the rubber plug when finished. The minimum recommended lubrication is every 12 months or 12,000 miles (19,312 km). More frequent lubrication may be required under extremely dusty or damp operating conditions.

LOWER RADIATOR HOSE HEATER OPTION - USE AND MAINTENANCE

⚠ CAUTION

Improper use of the lower radiator hose heater could result in damage to the engine or personal injury. Do not modify the location of the lower radiator hose heater.

The following points should be followed when operating a unit equipped with a lower radiator hose heater:

- Ensure cooling system is full of a proper mixture of water and engine coolant before each heater use.
- The heater is designed for all-night operation, however, 2-5 hours of heating just prior to starting is usually sufficient for proper engine starting.
- When the heater is in operation, the unit must be parked in a level position to maintain the proper orientation of the heater.

- Use only an undamaged, outdoors rated, three-prong grounded 120VAC extension cord with a minimum amperage rating of 10A. Connect to a properly grounded 120VAC, GFCI receptacle only.
- Unplug the extension cord from power first; then unplug the heater cordset from the extension cord before starting the engine.

GENERAL MAINTENANCE

Poorly maintained equipment can become a safety hazard. In order for the equipment to operate safely and properly over a long period of time, periodic maintenance and occasional repairs are necessary. **NEVER** perform even routine service (oil/filter changes, cleaning, etc.) unless all electrical components are shut down. When servicing this equipment always follow the instructions listed below.

- Before servicing this machine, make sure the control power switch is turned to “OFF/O”.
- The circuit breakers are open (“OFF/O”).
- The emergency stop switch is activated (pushed in).
- The negative (-) terminal on battery is disconnected.
- Attach a “DO NOT START” sign to the control panel. This will notify everyone that the unit is being serviced and will reduce the chance of someone inadvertently trying to start the unit.
- Never wash the unit with a high pressure hose or with any kind of power washer.
- Never wash the engine block or fuel tank with a power washer or steam cleaner. Water may enter the cabinet and collect in the generator windings or other electrical parts, causing damage.
- If the unit is stored outside, check for water inside the cabinet and generator and dry the unit thoroughly before starting.
- Inspect condition of electrical cords. **DO NOT** use unit if insulation is cut or worn through.
- Check the wheel lugs. Tighten or replace any that are loose or missing. If a tire has been removed for axle service or replaced, tighten the lugs in the order shown in *“Towing The Trailer” on page 13*.
- Check coolant levels. Refer to the engine operator’s manual when determining proper mixture.
 - Coolant is checked visually by inspecting the level in the coolant overflow jug near the radiator.
 - Normal operation is between the “FULL” and “ADD” markings on the overflow jug, this is known as “Normal Range”.
 - Coolant may be added directly to the jug **WHEN THE ENGINE IS STOPPED AND COMPLETELY COOL**.
- Check the oil levels. Refer to the engine operator’s manual when determining proper viscosity.
 - **DO NOT** start the unit if the engine oil level is below the “ADD” mark on the dipstick.
 - Normal operation is between the “FULL” and “ADD” markings on the dipstick.
 - Add oil only if the oil level is below the cross-hatch pattern on the dipstick. **DO NOT OVERFILL** the crankcase.
- Check fuel level.

Note: *During the first 100 hours of operation, avoid long periods of no load or sustained maximum load operation. If the unit is to run for longer than five minutes without a load, shut the engine down.*

BASIC MAINTENANCE SCHEDULE - KUBOTA ENGINE

NOTICE

Refer to the original equipment manufacturer's operating manual for a complete list of maintenance requirements. Failure to comply with the procedures as described in the engine operator manual will nullify the warranty, decrease performance and cause equipment damage or premature equipment failure. Maintenance records may be required to complete a warranty request.

Use the schedule in the following table as a guide for regular maintenance intervals. For additional or replacement copies of the engine operator's manual, contact an authorized dealer in your area.

Item	Daily	50 Hours	100 Hours	200 Hours	400 Hours	500 Hours	1 Year
Check Oil Level	◆						
Check Coolant Level	◆						
Check Fuel Level	◆						
Check Tire Pressure	◆						
Check All Electrical Connections	◆						
Inspect Radiator Fins For Debris, Clean As Required	◆						
Check Fuel Pipes and Clamp Bands		◆					
Clean Air Cleaner Element			◆				
Clean Fuel Filter			◆				
Check Fan Belt Tightness			◆				
Drain Water Separator			◆				
Check Radiator Hoses and Clamp Bands				◆			
Change Engine Oil				◆*			
Check Intake Air Line				◆			
Replace Oil Filter Cartridge					◆*		
Replace Fuel Filter Cartridge					◆		
Clean Water Separator					◆		
Lubricate Leveling Jacks						◆	
Remove Sediment In Fuel Tank						◆	
Replace Fan Belt						◆	
Replace Air Filter Element							◆**

* Change the engine oil and oil filter after the initial 50 hours of operation, then at the appropriate interval thereafter.

** Replace the air cleaner element yearly, or after six cleanings, whichever occurs first.

AC WIRING DIAGRAM

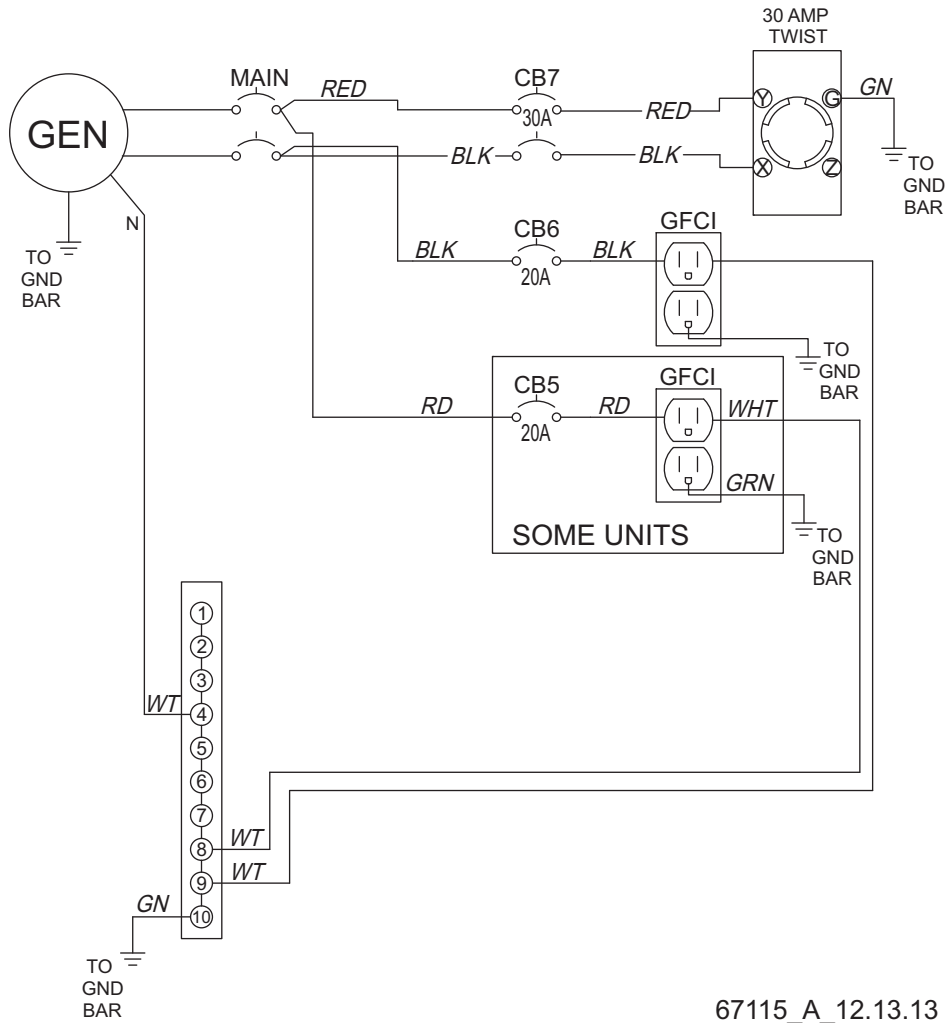

67115_A_12.13.13

DC WIRING DIAGRAM

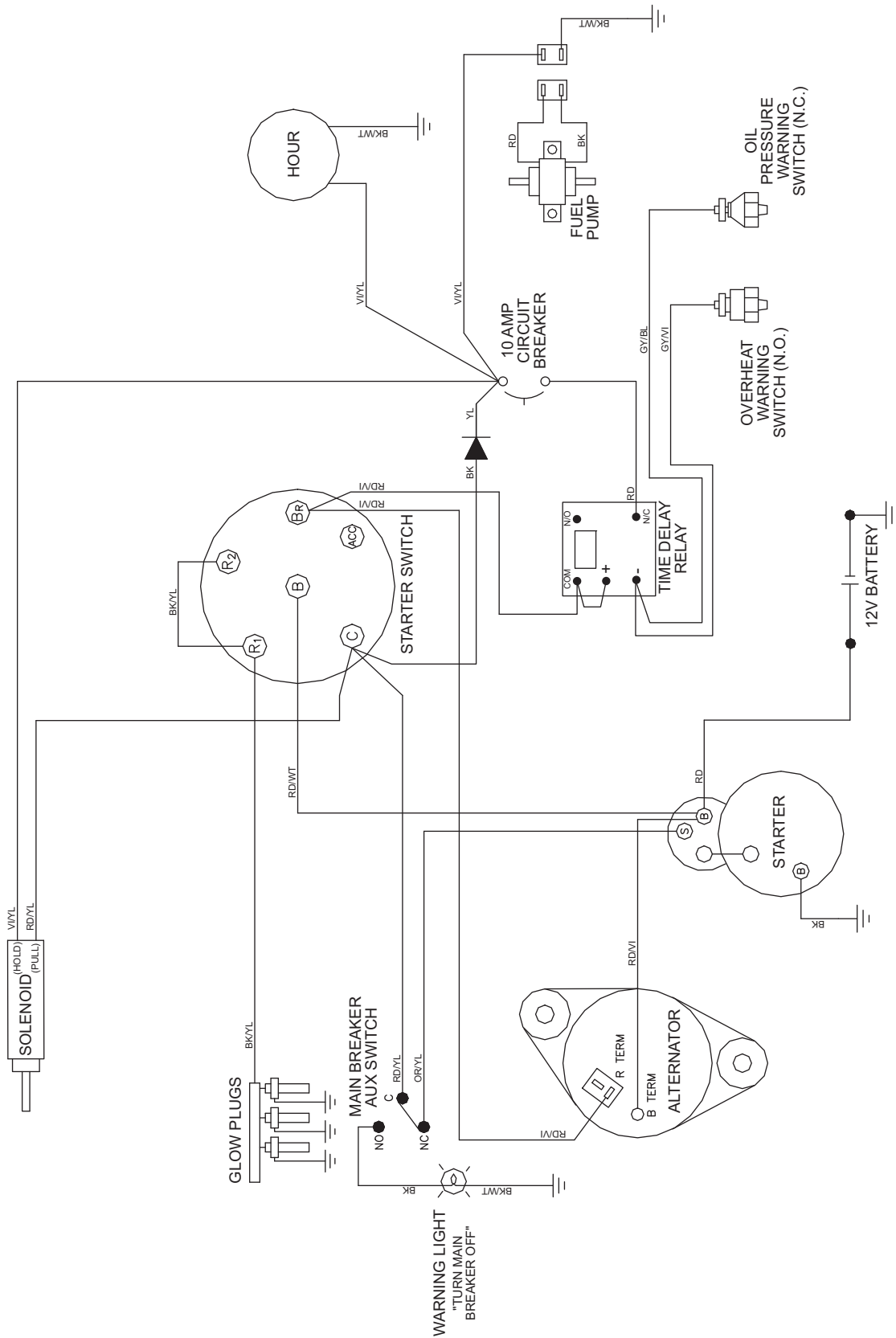

90339_E_01.30.14

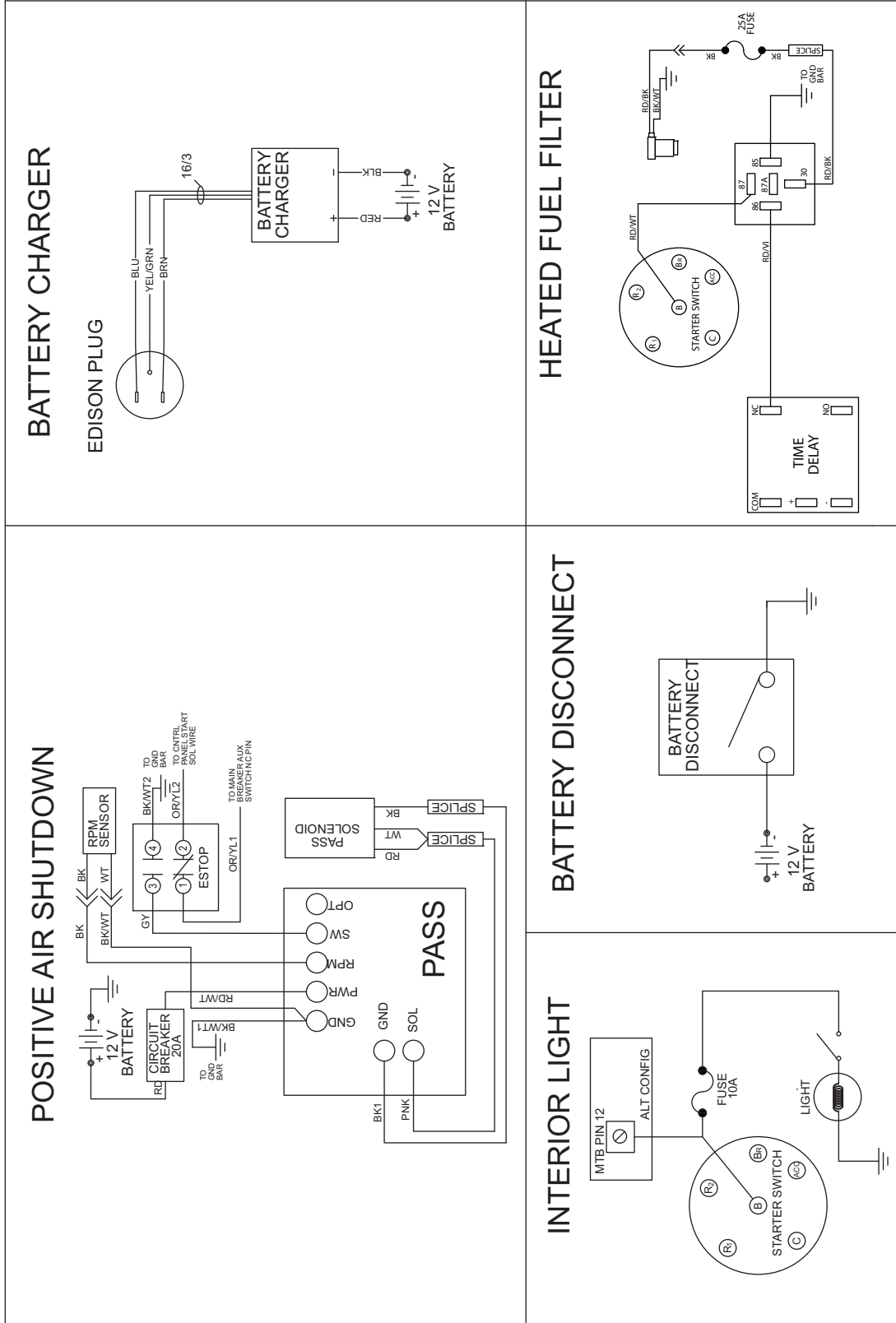

90323_I_11.18.13

TRAILER LIGHTS WIRING DIAGRAM

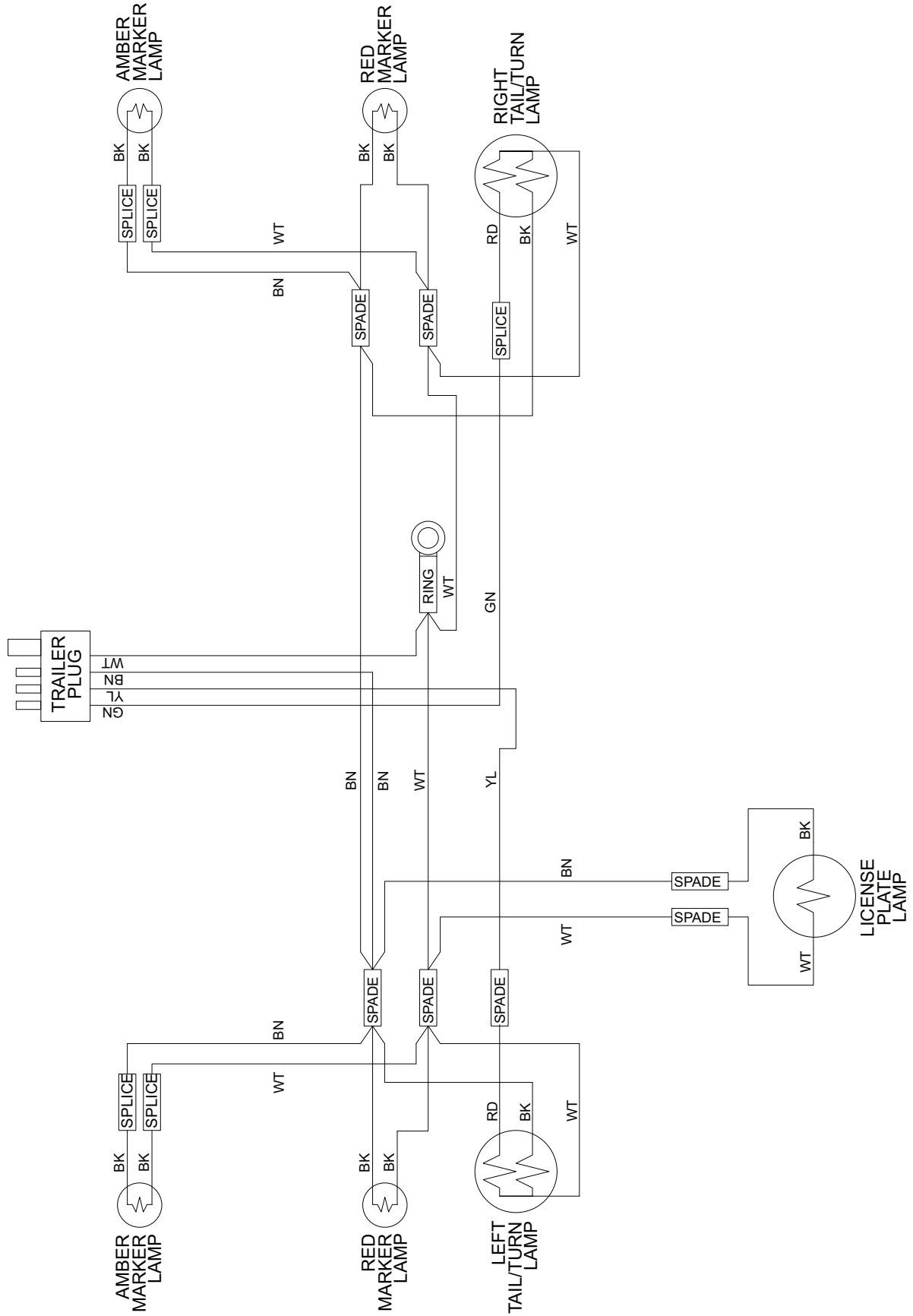

REV: A
PART NO: 10585
03.19.14