

To load for transportation

1. Load the fuel caddy onto a trailer or truck bed and place in horizontal position **ONLY** (valve and cap up). **DO NOT** place inside a vehicle trunk or inside the passenger compartment.
2. Secure the container with proper restraining devices to prevent movement in all directions. Proper restraining devices include tie-down straps, cables or chains that are in good condition and strong enough to withstand the forces that may be encountered during transportation. There should not be any sharp edges in contact with the plastic tank. The restraining devices may be wrapped around the tank body in the grooved ribs, around the molded handle, or around the axle. **DO NOT** attach restraining devices to the ball valve, hose fittings, or fill cap.
3. It is the vehicle operator's responsibility to comply with all federal, state, and local regulations for the transportation of fuel, and including the use of placards where required.

Storage

Once the container has been first used, all statements below apply, whether the container is empty, full or partially full.

1. It is the user's responsibility to review and comply with all local and state building and fire codes regarding allowed quantity of fuel that may be stored and the approved storage locations.
2. Keep out of reach of children.
3. Store in well-ventilated area.
4. Keep away from flame, pilot lights, stoves, heaters, electric motors and other sources of ignition.
5. **DO NOT** store inside a residence, living space or basement.
6. **DO NOT** store in an attached garage that is connected to residence or dwelling.
7. **DO NOT** store in vehicle passenger compartment or vehicle trunk.
8. **DO NOT** store in direct sunlight.

Item	Description	Qty	Part No.
1	Tank - 15 Gallon	1	N/A
2	Adapter O-Ring Groove	1	14GC-05
3	O-Ring	1	9464K39
4	1/2" NPT Swivel 90° Elbow	1	1501-8-8
5	1/2" NPT M x F Ball Valve	1	BV-1/2NPTMF
6	Dispensing Hose	1	80-593-14
7	Dispensing Nozzle	1	JL-5116-1
8	Wheels 10.0 x 3.0 Pneumatic with 5/8" Bearing	2	P1030-20S-R
9	Flat Washer 5/8" ID Zinc Plated	4	FRWSAW062
10	Axle Caps 5/8" ID Zinc Plated	1	14174
11	Fill Cap	1	201594

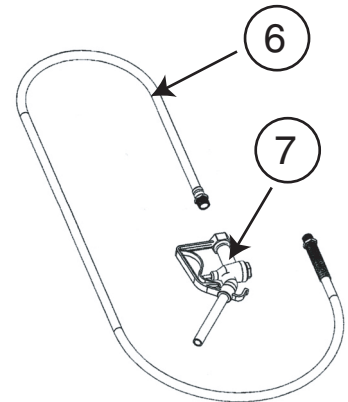
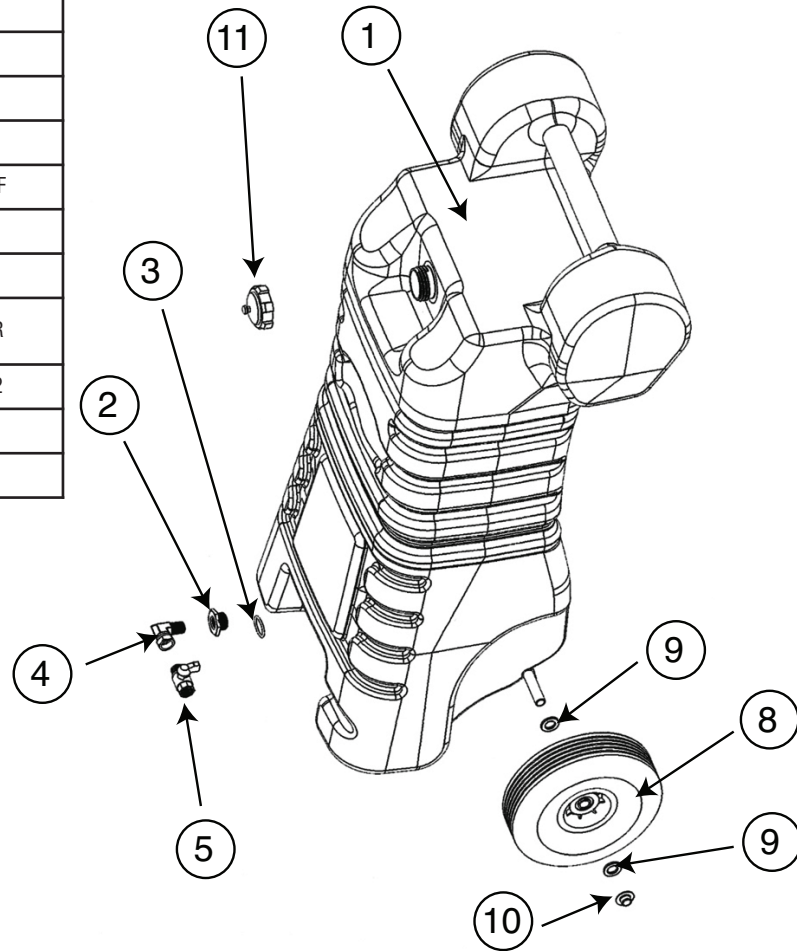

15-GALLON FUEL CADDY

(UN/DOT Approved)
Operator's Manual



For replacement parts
and technical questions,
please call
1-800-222-5381.

WARRANTY
1-year limited warranty

Distributed by
Northern Tool + Equipment Co., Inc.
Burnsville, Minnesota 55306
NorthernTool.com
Made in U.S.A.

Thank you very much for choosing a Roughneck product! For future reference, please complete the owner's record below:

Model: _____ Purchase Date: _____

Save the receipt, warranty and these instructions. It is important that you read the entire manual to become familiar with this product before you begin using it.

This gas caddy is designed for certain applications only. The distributor cannot be responsible for issues arising from modification. We strongly recommend this gas caddy not be modified and/or used for any application other than that for which it was designed. If you have any questions relative to a particular application, **DO NOT** use the gas caddy until you have first contacted the distributor to determine if it can or should be performed on the product.

For technical questions please call 1-800-222-5381.

WARNING: Read and understand all instructions. Failure to follow all instructions listed below may result in serious injury.

CAUTION: Do not allow persons to operate or assemble this gas caddy until they have read this manual and have developed a thorough understanding of how the gas caddy works.

WARNING: The warnings, cautions, and instructions discussed in this instruction manual cannot cover all possible conditions or situations that could occur. It must be understood by the operator that common sense and caution are factors which cannot be built into this product, but must be supplied by the operator.

SAVE THESE INSTRUCTIONS IMPORTANT SAFETY CONSIDERATIONS

GAS CADDY USE AND CARE

- Do not modify the gas caddy in any way. Unauthorized modification may impair the function and/or safety and could affect the life of the equipment. There are specific applications for which the gas caddy was designed.
- Always check of damaged or worn out parts before using the gas caddy. Broken parts will affect the gas caddy operation. Replace or repair damaged or worn parts immediately.
- Store idle gas caddy. When gas caddy is not in use, store it in a secure place out of the reach of children. Inspect it for good working condition prior to storage and before re-use.

⚠ DANGER GASOLINE – EXTREMELY FLAMMABLE

- VAPORS CAN EXPLODE**
- HARMFUL OR FATAL IF SWALLOWED**
- If swallowed, do not induce vomiting, call physician immediately.
- Keep out of reach of children.
- Avoid prolonged breathing of vapors.
- Do not siphon by mouth.
- Do not store in vehicle or living space.
- Store and use in well-ventilated area.
- Vapors can be ignited by a spark or flame source many feet away.
- Keep away from flame, pilot lights, stoves, heaters, electric motors and other sources of ignition.
- Keep container closed.
- Do not smoke near or while using this gas caddy

⚠ WARNING

- When using this product basic precautions should always be followed, including the following; **A)** Read all instructions before using this product. **B)** To reduce the risk of injury, close supervision is necessary.
- Ensure that all fittings and connections are tightened and leak free.
- Do not modify this tank, fittings, valves, or caps.
- Place container in horizontal position on ground when filling.
- Discharge static electricity before fueling by touching a metal surface away from the nozzle.
- Keep nozzle in contact with the container while filling. Do not use a nozzle lock-open device.
- Do not get back in you vehicle while refueling, re-entry could cause a static build up.
- Fill slowly to prevent the build up of static charges.
- If fire starts, do not remove nozzle. Back away immediately.
- Closely monitor flow to prevent spills and overfilling.
- Perform the entire closure procedure before using the gas caddy to transport fuel.
- Secure or strap container to trailer or truck bed. Do not place inside a vehicle trunk or inside passenger compartment.
- Do not use electronics or mobile phones while using this product
- Regulations for the transportation of gasoline vary from state to state, even locally. It is the vehicle operator's responsibility to review and comply with all federal, state, and local regulations.
- Review and comply with all building and fire codes concerning the proper storage of gasoline. It is the owner/users responsibility to comply with all building and fire codes.
- Do not store in direct sunlight.

⚠ CAUTION

- Use caddy for "one type of fuel only" to avoid possible contamination or damage to equipment or motor vehicles.
- Use care when maneuvering to prevent injury or loss of control. Seek assistance to avoid strain or injury when required.

Capacity and Dimensions:

Fill capacity vertical:	14.5 gal. (62,7 liter)*	Tare Weight:	28.0 lbs (12,7 kg)
Fill capacity horizontal:	14.5 gal. (62,7 liter)*	Gross Weight (15 gal of gasoline):	119.1 lbs (54.0 kg)*
Maximum volume of tank:	15.0 gal. (12,7 liter)	Dimensions (horizontal):	34.5 (L) x 22.25 (W) x 16.75 (H)

*when filled to just below the bottom of filler neck

Assembly Instructions

- Assemble the 1/2 inch threaded end of the hose (**A**) into the valve as shown. **DO NOT** use any pipe sealant or tape on this connection. The rotating nut on the 90° elbow will pull the valve against a metal cone seat to creating the seal. Tighten.
- Wrap the 3/4 inch pipe fitting end of hose (**B**) with PTFE tape or apply pipe sealant. Assemble into the dispensing nozzle and tighten.
- The tires are not inflated prior to shipment. Inflate both tires to 15 psi (1.0 bar) before using.

To fill container

- Confirm the filling location is safe and away from all sources of ignition, sparks, and flames.
- Place the fuel caddy container on the ground in horizontal position (valve and fill cap up) away from vehicle before filling. Placing the container on the ground allows a path for static charge to dissipate.
- Dissipate any static electricity by touching a metal surface away from the nozzle prior to removing nozzle from dispensing pump
- Remove fill cap and insert service station dispensing nozzle into the filler neck opening.
- Keep the service station dispensing nozzle in contact with the container opening while filling. **DO NOT** use nozzle lock-open device. **DO NOT** re-enter vehicle while filling your gas caddy or while refueling your vehicle. Re-entry could cause a static build up.
- Fill slowly to prevent the build up of static charges. Stop immediately if you sense the build up of static charges (sensation of hair raising or tingling of parts of body). **DO NOT** resume filling until static charges dissipate.
- Closely monitor flow to prevent spills and overfilling the container.
- Do not fill above the bottom of the threaded filler neck.
- Reinstall the fill cap.
- Wipe any residual fuel from outside of tank or allow to evaporate.

To dispense from container

- Position tank in upright vertical position.
- Slowly crack open fill cap to vent any internal pressure.
- Open foot valve by turning the ball valve handle clockwise as shown to be inline with the flow in the hose.
- Place tip of nozzle into container that is being filled. The nozzle must remain inside the container while dispensing.
- Fuel is gravity dispensed through nozzle. Squeeze handle to begin flow, release to stop.
- Monitor flow and liquid level to prevent spills.
- When finished drain remaining fuel back into the tank per the instructions below.

To drain fuel from hose back into the container

- Lay fuel caddy in horizontal position (valve and fill cap up).
- Elevate the nozzle above the hose, and slope the hose back to the valve to provide a clear path for fluid to drain.
- With the nozzle above the hose, squeeze the handle of the nozzle to allow hose to vent and fuel to drain back into the tank.
- Close the ball valve.

To close for transportation or storage

Return all fuel from hose back into tank per above instructions.

- Close the tank
 - Close ball valve by turning the handle until it stops in 90° position as shown. This indicates that the ball valve is in the closed position.
 - Turn fill cap in direction as shown until the cap seats on tank, then turn an additional 1/8 turn.
 - Turn manual vent in direction as shown until closed, then turn an additional 1/8 turn.

