

PORTABLE ADJ. HEIGHT WORKER STAND - PAHT-H-1924

APPROX WEIGHT: 39.96 lbs.
 DOES NOT INCLUDE WEIGHT OF POWER OR PACKAGING!!!

ANY ADDITIONS, DELETIONS, OR OMISSIONS MUST BE CORRECTED ON THIS DRAWING AS THIS DRAWING WILL BE CONSIDERED ALL INCLUSIVE

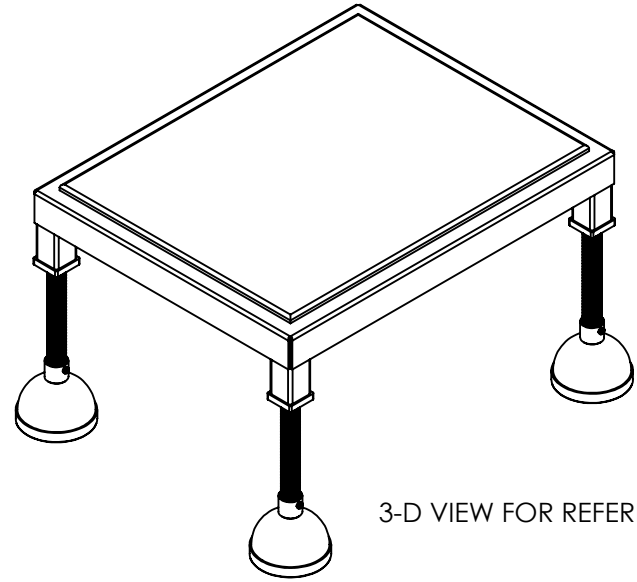
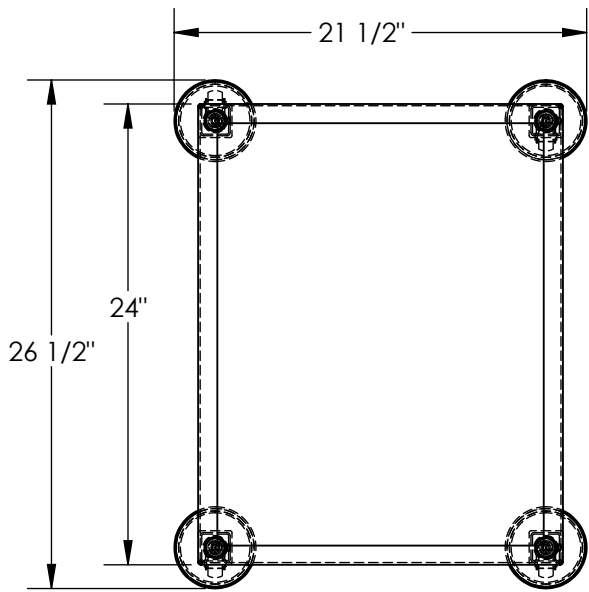

3-D VIEW FOR REFERENCE

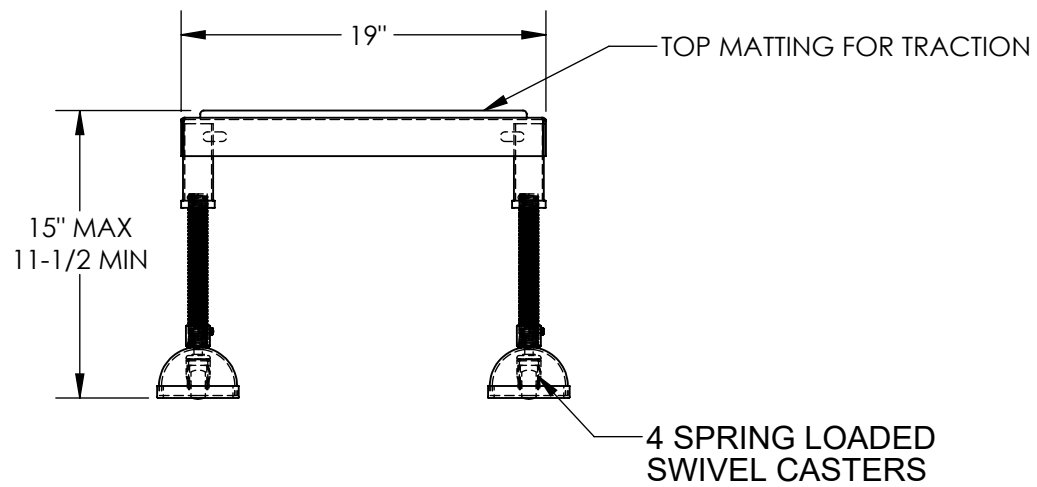

DIMENSION TOLERANCE ± 1/4"

ALL GRAPHICS PROVIDED ARE FOR REFERENCE ONLY. IF CERTAIN DIMENSIONS ARE CRITICAL PLEASE VERIFY THOSE DIMENSIONS WITH YOUR SALESPERSON

STANDARD FEATURES

- MODEL NUMBER IS PAHT-H-1924
- CAPACITY IS 500 LBS
- OVERALL WIDTH IS 21 1/2"
- USABLE WIDTH IS 19"
- OVERALL LENGTH IS 26 1/2"
- USABLE LENGTH IS 24"
- OVERALL HEIGHT IS 11-1/2 THRU 15"
- 4 ADJUSTABLE LENGTH LEGS
- 4 SPRING LOADED SWIVEL CASTERS
- DURABLE BAKED IN POWDER COATED YELLOW FINISH

A P P R O V A L	I, THE UNDERSIGNED, AGREE THAT THE PRODUCT AS REPRESENTED SATISFIES DESIGN AND DIMENSION REQUIREMENTS. I ALSO ACKNOWLEDGE MY DUTY TO CONFIRM PRODUCT AND INSTALLATION COMPLIANCE WITH ALL APPLICABLE FEDERAL, STATE AND LOCAL REGULATIONS AND STANDARDS.	
	UNITS REQUIRING APPROVAL DRAWINGS OR MODIFIED ARE NON-RETURNABLE	
	[] As drawn	[] As marked
	Signed: _____ Date: _____	
	Printed Name: _____	
	<i>LEAD TIME WILL START UPON RECEIPT OF SIGNED APPROVAL DRAWING</i>	

DISTRIBUTOR'S NAME:		P.O.#
VESTIL MANUFACTURING		X
DRAWN BY: MTS		W.O.#
DATE: 03/26/2015		X
REFERENCE: X		SALES: X
SCALE: 1:10		FILE NAME:
QUOTED LEAD TIME: X		14-007-185
QUOTE #		
X		