

PORTABLE ADJ. HEIGHT WORKER STAND - PAHT-L-1948 APPROX WEIGHT: 67.17 lbs.
 DOES NOT INCLUDE WEIGHT OF POWER OR PACKAGING!!!

ANY ADDITIONS, DELETIONS, OR OMISSIONS MUST BE CORRECTED ON THIS DRAWING AS THIS DRAWING WILL BE CONSIDERED ALL INCLUSIVE

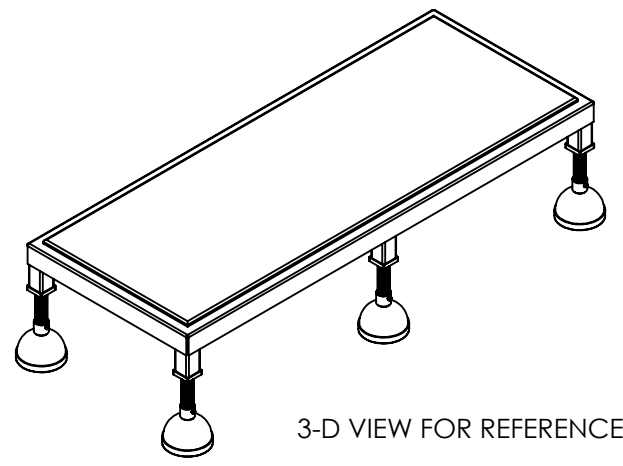

3-D VIEW FOR REFERENCE

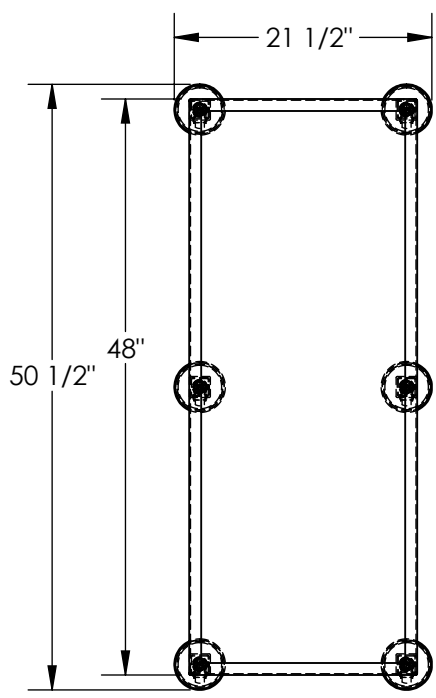
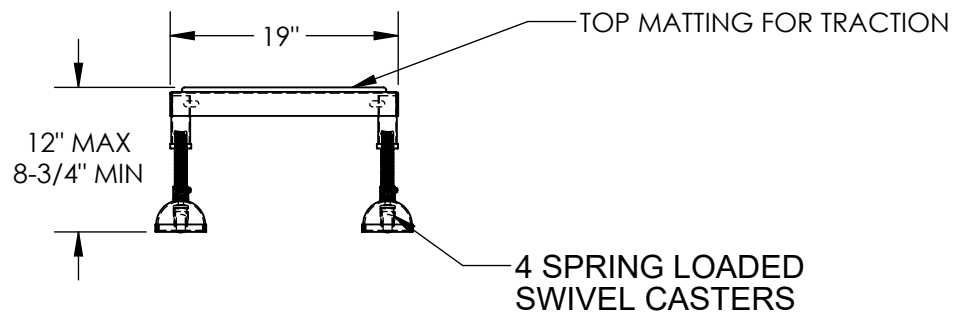

DIMENSION TOLERANCE ± 1/4"

ALL GRAPHICS PROVIDED ARE FOR REFERENCE ONLY. IF CERTAIN DIMENSIONS ARE CRITICAL PLEASE VERIFY THOSE DIMENSIONS WITH YOUR SALESPERSON

STANDARD FEATURES

- MODEL NUMBER IS PAHT-L-1948
- CAPACITY IS 500 LBS
- OVERALL WIDTH IS 21 1/2"
- USABLE WIDTH IS 19"
- OVERALL LENGTH IS 50 1/2"
- USABLE LENGTH IS 48"
- OVERALL HEIGHT IS 8-3/4 THRU 12"
- 6 ADJUSTABLE LENGTH LEGS
- 6 SPRING LOADED SWIVEL CASTERS
- DURABLE BAKED IN POWDER COATED YELLOW FINISH

A P P R O V A L	I, THE UNDERSIGNED, AGREE THAT THE PRODUCT AS REPRESENTED SATISFIES DESIGN AND DIMENSION REQUIREMENTS. I ALSO ACKNOWLEDGE MY DUTY TO CONFIRM PRODUCT AND INSTALLATION COMPLIANCE WITH ALL APPLICABLE FEDERAL, STATE AND LOCAL REGULATIONS AND STANDARDS.	
	UNITS REQUIRING APPROVAL DRAWINGS OR MODIFIED ARE NON-RETURNABLE	
	[] As drawn [] As marked	
	Signed: _____ Date: _____	
Printed Name: _____		
LEAD TIME WILL START UPON RECEIPT OF SIGNED APPROVAL DRAWING		

DISTRIBUTOR'S NAME:		P.O.#
VESTIL MANUFACTURING		X
DRAWN BY: MTS		DATE: 03/26/13
REFERENCE: X		SCALE: 1:16
QUOTED LEAD TIME: X	QUOTE # X	FILE NAME: 14-007-183
		SALES: X