

# FORGED STEEL FORK WITH CARRIAGE PIN - F4-1.75-60-CPL

APPROX WEIGHT: 147 lbs.  
 DOES NOT INCLUDE WEIGHT OF POWER OR PACKAGING!!!

\*\*\* ANY ADDITIONS, DELETIONS, OR OMISSIONS MUST BE CORRECTED ON THIS DRAWING AS THIS DRAWING WILL BE CONSIDERED ALL INCLUSIVE \*\*\*  
 ALL GRAPHICS PROVIDED ARE FOR REFERENCE ONLY. IF CERTAIN DIMENSIONS ARE CRITICAL PLEASE VERIFY THOSE DIMENSIONS WITH YOUR SALESPERSON

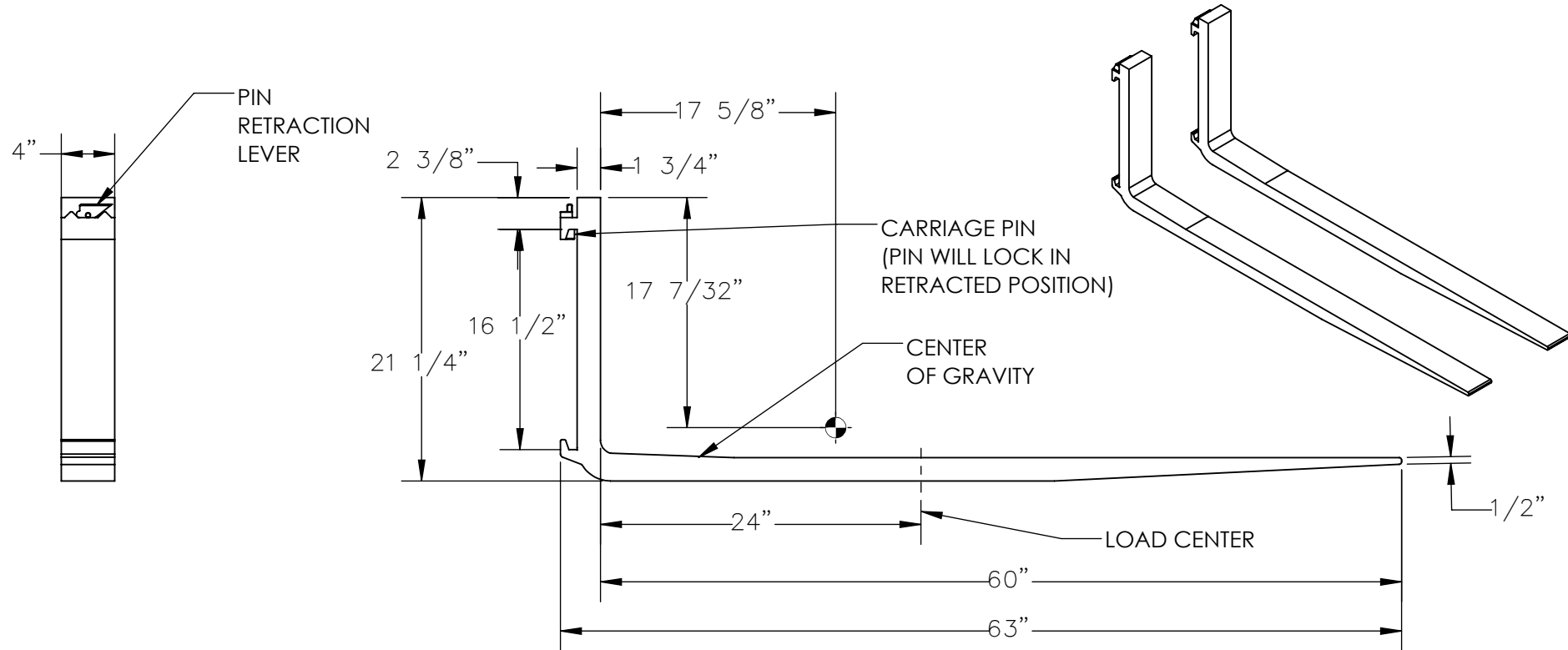

DIMENSION TOLERANCE  $\pm 1/4$ "

## STANDARD FEATURES

MODEL NUMBER IS F4-1.75-60-CPL  
 FORK WIDTH: 4"  
 DESIGNED FOR CLASS II CARRIAGE MOUNTING  
 OVERALL LENGTH: 51"  
 OVERALL HEIGHT: 21 1/4"  
 USABLE LENGTH: 60"  
 SOLID STEEL CONSTRUCTION  
 DURABLE LIQUID PAINT BLACK FINISH  
 CAPACITY EVENLY DISTRIBUTED =  
 5,000 LBS. @24" LOAD CENTER PER PAIR

APPROX. WEIGHT / LOST LOAD = 147 LBS.  
 MINIMUM EFFECTIVE THICKNESS = 0  
 VERTICAL CENTER OF GRAVITY = 17 7/32"  
 HORIZONTAL CENTER OF GRAVITY = 17 5/8"

NEVER EXCEED LOAD CENTER  
 RATING PER FORKTRUCK  
 MANUFACTURERS GUIDELINES.  
 DO NOT USE THIS FORK TRUCK  
 ATTACHMENT IF LOAD WILL EXCEED  
 FORK TRUCK MANUFACTURER'S  
 LOAD CENTER RATING

<b>APPROVAL</b>	I, THE UNDERSIGNED, AGREE THAT THE PRODUCT AS REPRESENTED SATISFIES DESIGN AND DIMENSION REQUIREMENTS. I ALSO ACKNOWLEDGE MY DUTY TO CONFIRM PRODUCT AND INSTALLATION COMPLIANCE WITH ALL APPLICABLE FEDERAL, STATE AND LOCAL REGULATIONS AND STANDARDS.	
	<b>UNITS REQUIRING APPROVAL DRAWINGS OR MODIFIED ARE NON-RETURNABLE</b>	
	[ ] As drawn [ ] As marked	
	Signed: _____	Date: _____
	Printed Name: _____	
<b>LEAD TIME WILL START UPON RECEIPT OF SIGNED APPROVAL DRAWING</b>		

DISTRIBUTOR'S NAME:		P.O.#
<b>VESTIL MANUFACTURING</b>		X
		W.O.#
		X
DRAWN BY: X	DATE: XX/XX/XX	SALES: X
REFERENCE: X	SCALE: 1:12	FILE NAME:
QUOTED LEAD TIME: X	QUOTE # X	08-007-532