

REVISION HISTORY				
REV	DATE	EFFCTV.	BY	DESCRIPTION
1	9/29/2016	R.C.	JEP	UPDATED TO RELLECT REV. 1 OF 61392-1, 19.54 (19.42)

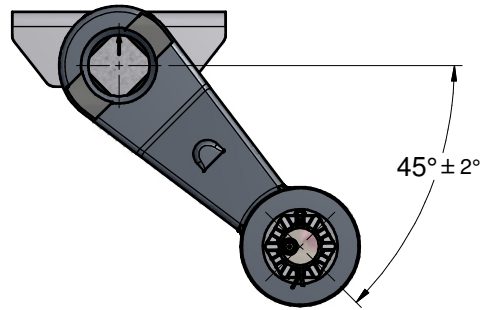
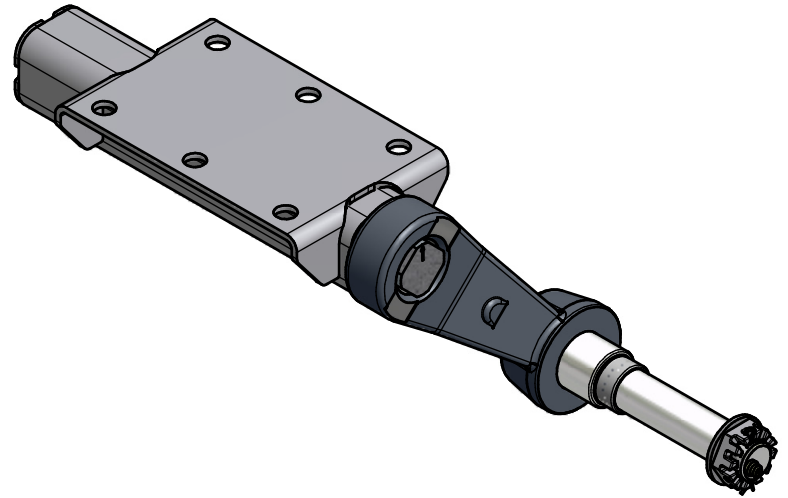

NOTES:

- 1.) AXLE FINISH - POWDER COAT, BLACK.
- 2.) TORSION ARM FINISH - E-COAT, BLACK.
- 3.) ASSEMBLY IS **LEFT HAND** AS SHOWN.

Parts List			
ITEM	QTY	PART NUMBER	DESCRIPTION
1	1	61392-2L	500# 45° DN STUB TORSION AXLE - LEFT
2	1	80047	C1040-1045 HR STEEL - 1.50 D. x 8.18 L.
3	1	12099	SUPER LUBE GREASE ZERK (BODY ONLY)
4	1	10528X	WASHER SPRING 1-IN ID X 2-IN DACROMET
5	1	10665X	NUT CASTLE SPINDLE HEX 1 IN GALVX
6	1	10560SS	PIN COTTER 5/32 X 2 SS
7	1	10520	WASHER FLAT SPINDLE 1IN
8	1	10634	NUT SPINDLE 1-14 UNS 2B 12 CASTLE
9	1	10560	PIN COTTER 5/32X2 ZINC

NORTHERN TOOL #48223
 ONE PAIR, RIGHT & LEFT
 CAPACITY IS 500 LB. TOTAL, 250 LB. PER SIDE

CONFIDENTIALITY NOTICE: THIS DRAWING AND ALL INFORMATION CONTAINED WITHIN IT ARE THE PROPERTY OF TIE DOWN ENGINEERING, ATLANTA, GA 30336. ALL RIGHTS ARE RESERVED.

Date:	3/4/2015
Design:	elliot.patton
Approved:	

Unspecified Tolerances:

Fractions	± 1/32
Decimal	± .06
Decimal	± .030
Angles	± 0.25°
Holes	± .008

Tie Down Engineering
 5901 Wheaton Drive Atlanta Georgia 0336

500# (250# PER SIDE) 45° DN STUB TORSION AXLE

LEFT ASSEMBLY; w/ SPINDLES & HARDWARE

Part No.: 61392L Page: 1 of 1 Rev.: 1