



UNIVERSAL UTILITY TRUCK RACK

Owner's Manual



⚠ WARNING: Read carefully and understand all ASSEMBLY AND OPERATION INSTRUCTIONS before operating. Failure to follow the safety rules and other basic safety precautions may result in serious personal injury.

Item # 48112

Thank you very much for choosing an Ironon product!

For future reference, please complete the owner's record below:

Serial Number/Lot Date Code: _____

Purchase Date: _____

Save the receipt, warranty, and this manual. It is important that you read the entire manual to become familiar with this product before you begin using it.

This Universal Utility Truck Rack is designed for certain applications only. The distributor cannot be responsible for issues arising from modification or use of this product in an application for which it was not designed. We strongly recommend that this product not be modified and/or used for any application other than that for which it was designed. If you have questions about a particular modification or application, DO NOT use the product until you have first contacted the distributor to determine if the product can or should be modified or used in such an application.

For technical questions, please call **1-800-222-5381**.

Table of Contents

Intended Use.....	4
Technical Specifications	4
Important Safety Considerations	5
Safety Labels	6
Assembly	7
Parts Diagram	10
Parts List	10
Hardware List	11
Replacement Parts	11
Limited Warranty	12

Intended Use

This unique truck rack transports anything from construction materials and ladders to kayaks and more!

Technical Specifications

Property	Specification
Minimum Length	57in.
Maximum Length	77in.
Minimum Width	13.8in.
Minimum Height	33.5in.
Maximum Weight Capacity	500 lbs.

WARNING

- Read and understand all instructions. Failure to follow all instructions may result in serious injury.
- The warnings, cautions, and instructions in this manual cannot cover all possible conditions or situations that could occur. Exercise common sense and caution when using this tool. Always be aware of the environment and ensure that the tool is used in a safe and responsible manner.
- DO NOT allow persons to operate or assemble this product until they have read this manual and have developed a thorough understanding of how the product works.

SAVE THESE INSTRUCTIONS

Important Safety Considerations

- **DO NOT** modify the product in any way. Unauthorized modification may impair the function and/or safety and could affect the life of the product. There are specific applications for which the product was designed.
- **Use the right tool for the job. DO NOT** attempt to force a small equipment to do the work of larger industrial equipment. There are certain applications for which this equipment was designed. It will do the job better and more safely at the capacity for which it was intended. **DO NOT** use this equipment for a purpose for which it was not intended.
- **Industrial or commercial applications must follow OSHA requirements.**

⚠ WARNING

WORK AREA SAFETY

- Inspect the work area before installation. Keep work area clean, dry, free of clutter, and well lit. Cluttered, wet, or dark work areas can result in injury. Installing the truck rack in confined work areas may put you dangerously close to other cutting tools and rotating parts.
- Do not allow the rack to come into contact with an electrical source. The rack is not insulated and contact will cause electrical shock.
- Keep children and bystanders away from the work area while installing the truck rack.
- Be aware of all power lines, electrical circuits, water pipes, and other mechanical hazards in your work area. Some of these hazards may be below the work surface hidden from your view and may cause personal harm or property damage if unintentionally contacted.

PERSONAL SAFETY

- Stay alert, watch what you are doing, and use common sense when installing the truck rack, loading and unloading. Do not load the rack while you are tired or under the influence of drugs, alcohol, or medication. A moment of inattention may result in serious personal injury.
- Use safety apparel and equipment when necessary. Use ANSI-approved safety goggles or safety glasses with side shields, or when needed, a face shield. Use a dust mask in dusty work conditions. Also use non-skid safety shoes, hardhat, gloves, dust collection systems, and hearing protection when appropriate. This applies to all persons in the work area.
- Do not overreach when loading and unloading. Keep proper footing and balance at all times.

OPERATION SAFETY

- Carrying any load can be hazardous. All loads must be tied down securely to the rack to prevent them from vibrating or sliding forward, backward, laterally or being blown off or broken by unexpected wind or road hazards such as potholes.
- Check each time you install the rack, load the rack, as well as daily to ensure that all connections are tight. Periodically check welds for cracking caused by metal fatigue.
- Avoid roll over by ensuring that loads are not top-heavy. High loads must be transported with **GREAT CAUTION** to prevent loads from striking low overhead objects or tipping during turns, abrupt stops, or high winds.

⚠ CAUTION

RACK USE AND CARE

- Do not over fill the rack. Racks do a better and safer job when used in the manner for which they are designed. Plan your work, and do not overload.
- Check for damaged parts before each use. Carefully check that the rack will operate properly and perform its intended function. Replace damaged or worn parts immediately. Never load the rack with a damaged part.
- Do not let children play with or around the rack. It is not a toy. Store it in a dry, secure place out of the reach of children. Inspect the rack for good working condition prior to storage and before re-use.
- Use only accessories that are recommended by the manufacturer for use with your rack. Accessories that may be suitable for one rack may create a risk of injury when used with another rack. Be aware of the different loading capacities of each accessory.
- Inspect the rack and accessories for damage or excessive wear before each use. If you find damage do not use the rack.

Safety Labels

⚠ WARNING

RATED CAPACITY 500 lbs. DO NOT OVERLOAD!

1. Follow DOT regulations regarding installation and use. Do not use if rack impedes your view or driving ability.
2. For installation, loading and unloading: Park truck on a flat, level, hard surface well away from traffic. Place transmission in park/neutral and set parking brake.
3. Do not load or drive with rack attached to vehicle if not fully installed per the manufacturer provided instructions.

4. Inspect work area for hazards before installing.
5. Verify that installation surface has no hidden wires before drilling or driving screws.
6. Install only according to instructions. Improper installation may cause damage to persons or property.
7. Wear ANSI-approved safety goggles and heavy-duty work gloves during assembly and installation.
8. Keep children and bystanders out of the area during installation.

9. Do not install, load or unload when tired or when under the influence of drugs or medication.
10. Weight capacity and other product capabilities apply to properly and completely installed product only.
11. Do not let children use or play with rack.
12. Ensure all loads are properly fastened before driving.
13. Inspect before each use. If you suspect that any part is damaged or defective, remove rack from vehicle before driving.

Assembly

For assembly of this item, you will need an open wrench, an Allen wrench and either a cordless or electric drill with a 7/16in. drill bit.

Recommended Tools



Open Wrench (2pc)
Size=17mm



Allen Wrench (1pc)
Size=5mm

Procedure

1. Set the rack to the high (Fig. 1) or low (Fig. 2) position, whichever is best for the cargo and the truck, by flipping the Left and Right Crossbraces (1 and 2). For bowed canoes, the high position is recommended. If you choose to flip the Crossbraces (1 and 2), you will have to remove and replace the Caps.

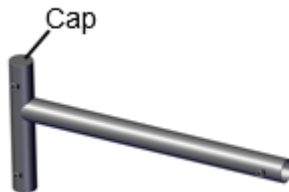

Fig. 1

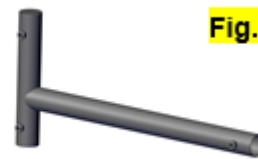

Fig. 2

2. Insert the Crossbraces (1 and 2) into the Crossbrace Extension (3) (Fig. 3) and set the entire assembly on top of the Left and Right Upright Legs (3 and 4). (Fig. 4)

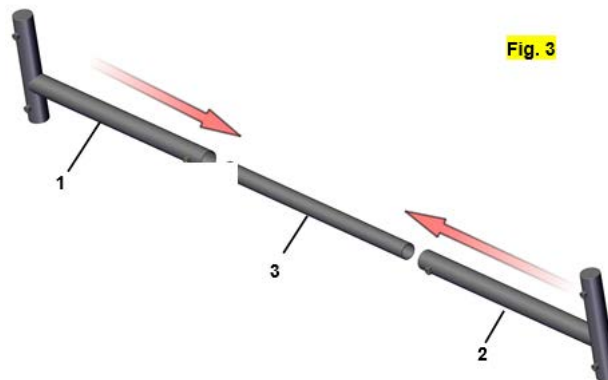
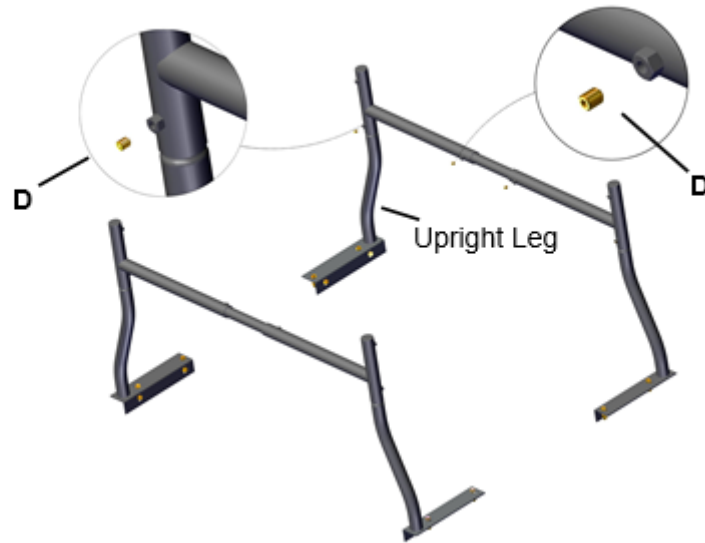

Fig. 3

3. Center the Crossbraces (1 and 2) left to right and secure them with M10*12 Allen Head Set Screw (D). (Fig. 4)
4. Secure the Crossbrace (1 and 2) to each Upright leg with M10*12 Allen Head Set Screw (D). (Fig. 4)

Fig. 4



5. Position the front of the Upright Legs as close to the cab as possible. Attach the mounting plates to the truck's bed rail by drilling $7/16''$ holes in the bed rail and lip, and then securing the mounting plate with two sets of Hex Bolt (A), Flat Washer (B), and M10 Lock Nut (C) through the top and side of the Mounting Plate. (Fig. 5)

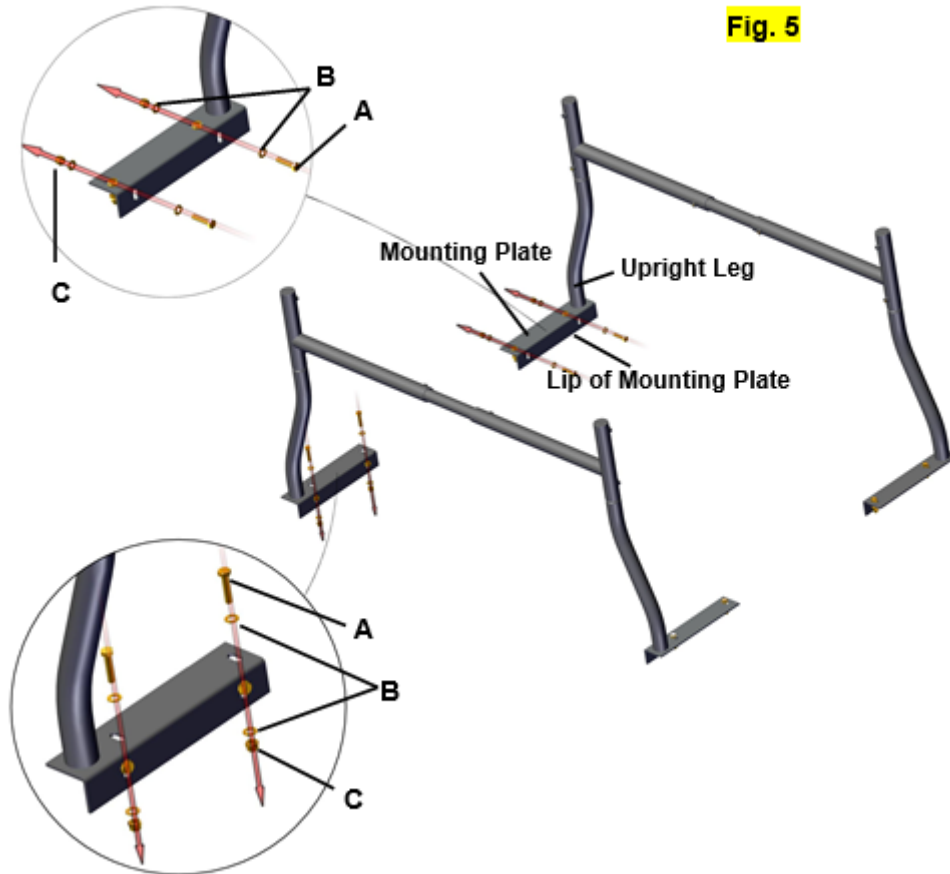

Parts Diagram

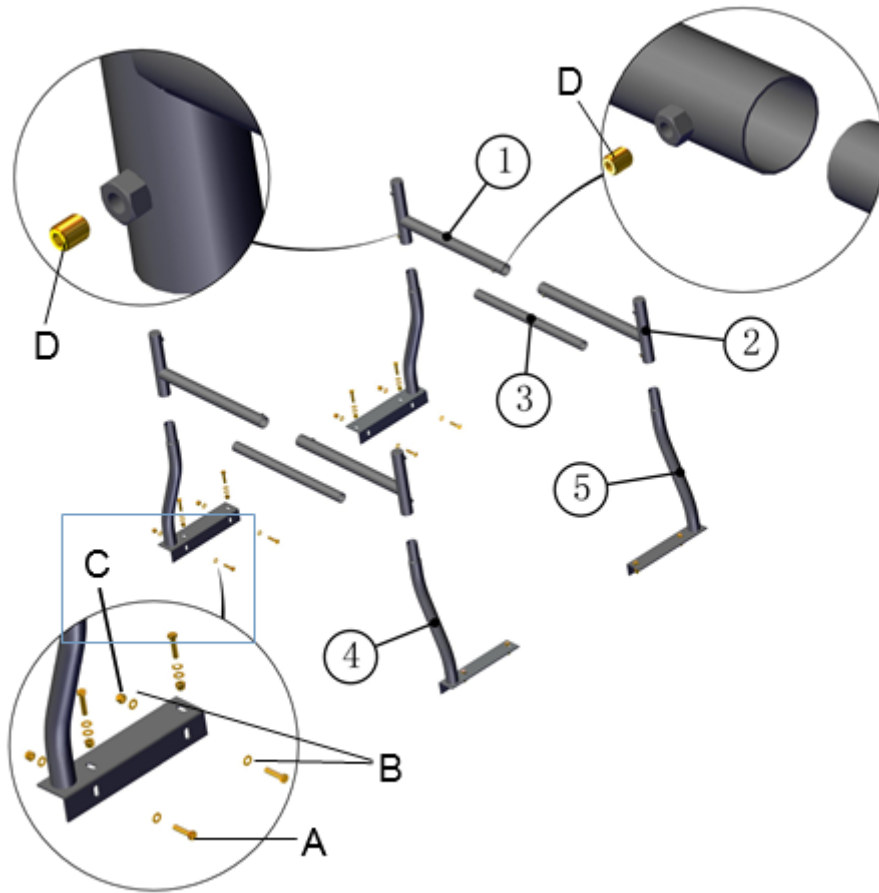

Parts List

Item#	Description	Quantity
1	Left Crossbrace	2
2	Right Crossbrace	2
3	Crossbrace Extension	2
4	Left Upright	2
5	Right Upright	2

Hardware List

Hardware	Description	Pic	Quantity
A	M10*45 Hex Bolt		16
B	M10 Flat Washer		32
C	M10 Lock Nut		16
D	M10*15 Allen Head Set Screw		8

Replacement Parts

- For replacement parts and technical questions, please call Customer Service at **1-800-222-5381**.
- Not all product components are available for replacement. The illustrations provided are a convenient reference to the location and position of parts in the assembly sequence.
- When ordering parts, the following will be required: Model Number, Serial Number/Lot Date Code, and Description.
- The distributor reserves the rights to make design changes and or improvements to product lines and manuals without notice.

Limited Warranty

Limited Warranty

Northern Tool and Equipment Company, Inc. ("We" or "Us") warrants to the original purchaser only ("You" or "Your") that the Ironton product purchased will be free from material defects in both materials and workmanship, normal wear and tear excepted, for a period of six months from date of purchase. The foregoing warranty is valid only if the installation and use of the product is strictly in accordance with product instructions. There are no other warranties, express or implied, including the warranty of merchantability or fitness for a particular purpose. If the product does not comply with this limited warranty, Your sole and exclusive remedy is that We will, at our sole option and within a commercially reasonable time, either replace the product without charge to You or refund the purchase price (less shipping). This limited warranty is not transferable.

Limitations on the Warranty

This limited warranty does not cover: (a) normal wear and tear; (b) damage through abuse, neglect, misuse, or as a result of any accident or in any other manner; (c) damage from misapplication, overloading, or improper installation; (d) improper maintenance and repair; and (e) product alteration in any manner by anyone other than Us, with the sole exception of alterations made pursuant to product instructions and in a workmanlike manner.

Obligations of Purchaser

You must retain Your product purchase receipt to verify date of purchase and that You are the original purchaser. To make a warranty claim, contact Us at 1-800-222-5381, identify the product by make and model number, and follow the claim instructions that will be provided. The product and the purchase receipt must be provided to Us in order to process Your warranty claim. Any returned product that is replaced or refunded by Us becomes our property. You will be responsible for return shipping costs or costs related to Your return visit to a retail store.

Remedy Limits

Product replacement or a refund of the purchase price is Your sole remedy under this limited warranty or any other warranty related to the product. We shall not be liable for: service or labor charges or damage to Your property incurred in removing or replacing the product; any damages, including, without limitation, damages to tangible personal property or personal injury, related to Your improper use, installation, or maintenance of the product; or any indirect, incidental or consequential damages of any kind for any reason.

Assumption of Risk

You acknowledge and agree that any use of the product for any purpose other than the specified use(s) stated in the product instructions is at Your own risk.

Governing Law

This limited warranty gives You specific legal rights, and You also may have other rights which vary from state to state. Some states do not allow limitations or exclusions on implied warranties or incidental or consequential damages, so the above limitations may not apply to You. This limited warranty is governed by the laws of the State of Minnesota, without regard to rules pertaining to conflicts of law. The state courts located in Dakota County, Minnesota shall have exclusive jurisdiction for any disputes relating to this warranty.



Distributed by
Northern Tool and Equipment Company, Inc.
Burnsville, Minnesota 55306
NorthernTool.com

Made in China