

SELF-DUMPING STEEL HOPPER - D-100-LD-NB

APPROX WEIGHT: 468.67 lbs.

DOES NOT INCLUDE WEIGHT OF POWER OR PACKAGING!!!

*** ANY ADDITIONS, DELETIONS, OR OMISSIONS MUST BE CORRECTED ON THIS DRAWING AS THIS DRAWING WILL BE CONSIDERED ALL INCLUSIVE ***

ALL GRAPHICS PROVIDED ARE FOR REFERENCE ONLY. IF CERTAIN DIMENSIONS ARE CRITICAL PLEASE VERIFY THOSE DIMENSIONS WITH YOUR SALESPERSON

ADDITION OF CASTERS MAY CHANGE WEIGHT CAPACITY BASED ON CASTER RATING

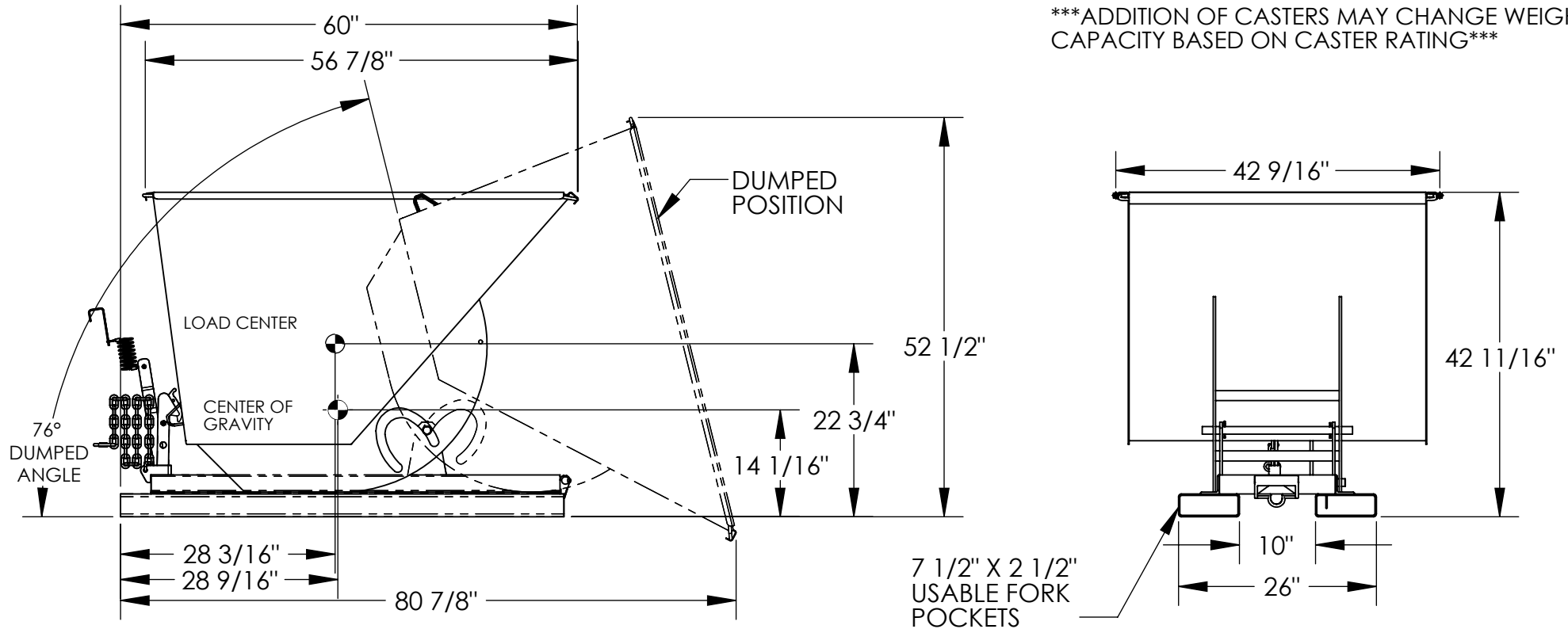

DIMENSION TOLERANCE ± 1/4"

STANDARD FEATURES

MODEL NUMBER: D-100-LD-NB
 VOLUME: 1 CU. YDS.
 CAPACITY: 2,000 LBS.
 OVERALL WIDTH: 42 9/16"
 OVERALL LENGTH: 61 1/8"
 OVERALL HEIGHT: 42 11/16"
 PULL CABLE IS AT LEAST: 48"
 DURABLE BAKED IN POWDER
 COATED BLUE FINISH

SPECIAL FEATURES

NONE

APPROX. WEIGHT / LOST LOAD = 468.67
 MINIMUM EFFECTIVE THICKNESS = LESS THAN 1"
 VERTICAL CENTER OF GRAVITY = 14 1/16"
 HORIZONTAL CENTER OF GRAVITY = 28 9/16"

NEVER EXCEED LOAD CENTER RATING PER FORKTRUCK MANUFACTURERS GUIDELINES.

DO NOT USE THIS FORK TRUCK ATTACHMENT IF LOAD WILL EXCEED FORK TRUCK MANUFACTURER'S LOAD CENTER RATING

APPROVAL

I, THE UNDERSIGNED, AGREE THAT THE PRODUCT AS REPRESENTED SATISFIES DESIGN AND DIMENSION REQUIREMENTS. I ALSO ACKNOWLEDGE MY DUTY TO CONFIRM PRODUCT AND INSTALLATION COMPLIANCE WITH ALL APPLICABLE FEDERAL, STATE AND LOCAL REGULATIONS AND STANDARDS.
UNITS REQUIRING APPROVAL DRAWINGS OR MODIFIED ARE NON-RETURNABLE

[] As drawn [] As marked

Signed: _____ Date: _____

Printed Name: _____

LEAD TIME WILL START UPON RECEIPT OF SIGNED APPROVAL DRAWING

DISTRIBUTOR'S NAME:		P.O.#
VESTIL MANUFACTURING		X
DRAWN BY: TAL		W.O.#
DATE: 05/07/2025		X
REFERENCE: X	SCALE: 1:20	SALES: X
QUOTED LEAD TIME: X	QUOTE # X	FILE NAME:
		37-007-022-001