

Instruction Guide

John Deere 8030 Series Window Step - (PN: 3416)

1. Fasten the **front bolt-on steps** in the desired position on the **front step weldment** using five 5/16" x 3/4" bolts and flange nuts. Do not use the hole closest to the tractor at this time. For tractors with front dual wheels, install only one **front bolt-on step** in the center mounting location.
2. For IVT tractors, attach the **IVT bracket** using the holes labeled "**hole set 2**". For Power Shift tractors, use the holes labeled "**hole set 1**". Fasten with a 5/16" x 3/4" bolt and flange nut in the top hole and a 5/16" x 1" bolt and flange nut in the bottom hole.
3. Bolt the end of the **IVT bracket** to the tractor using two 20mm x 45mm bolts and two 3/4" flat washers.
4. Fasten the **side step section** to the **front step weldment** using two 5/16" x 1" bolts and flange nuts.

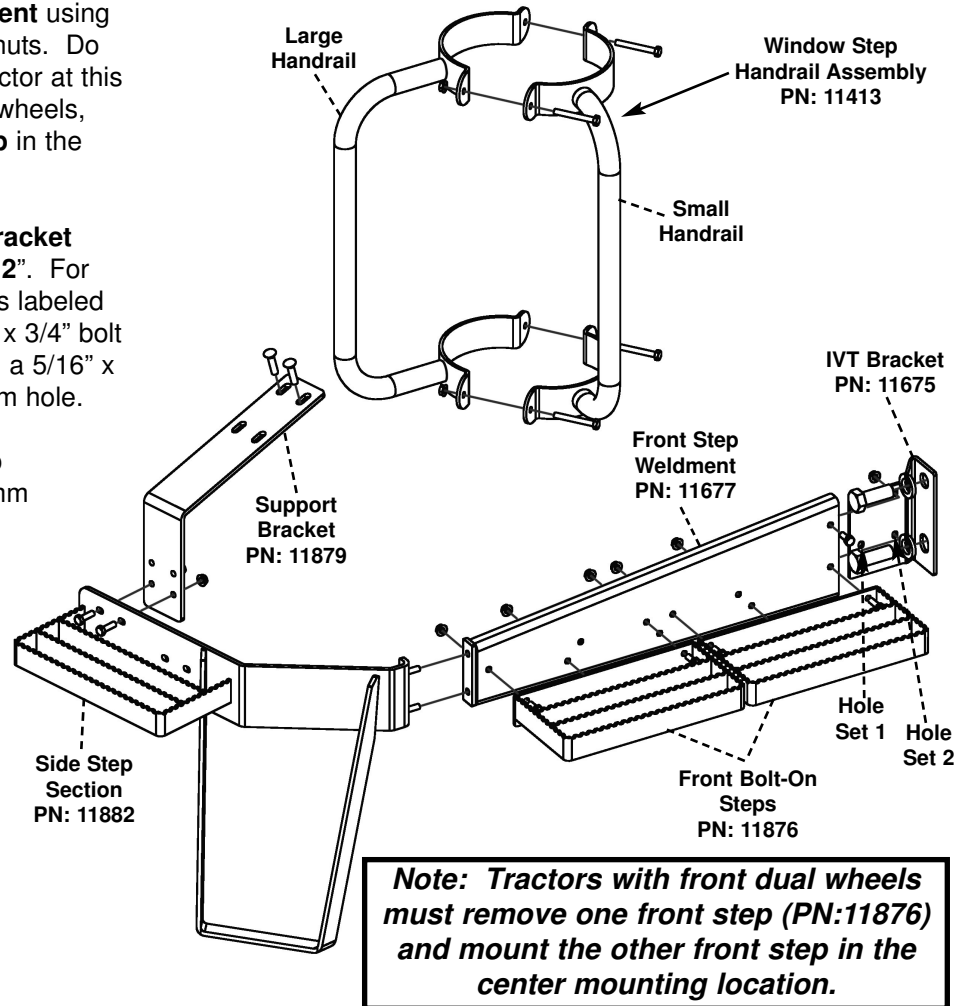

5. Fasten the lower end of the **support bracket** to the **side step section** using two 5/16" x 1" bolts and flange nuts.
6. Fasten the upper end of the **support bracket** to the fuel tank strap using two 10mm x 20mm bolts.
7. Locate the **handrail** to the desired height on the muffler shield.
8. Fasten the **handrails** together using four 5/16" x 2 1/2" bolts and flange nuts.
9. **After step installation, check turning radius of front tires for interference with step.**

NOTE! - When Installing This Application

Do not tighten any bolts until all parts have been assembled to the tractor.