

INDUSTRIAL - AQUEOUS PARTS CLEANER

OPERATION & INSTRUCTION MANUAL

EM4000

I. Introduction

A. Manufacturer's Statement

This manual will provide you with important information about the Aqueous Parts Cleaners and will instruct you on how to use this equipment in a safe manner.

The information contained in this manual is necessary for the safe, proper setup and operation of your Aqueous Parts Cleaner.

Keep this manual, along with the Material Safety Data Sheets (MSDS) for the solution in use, within easy reach of the operator of this parts cleaner.

The equipment described in this manual is subject to change. The manufacturer reserves the right to change equipment at any time as part of normal product improvement. Some improvements may have been made after this manual was printed. For the latest information on your equipment, contact the manufacturer.

B. General Information

CAUTION

READ AND UNDERSTAND ALL LABELS, MSDS, AND THIS INSTRUCTION MANUAL BEFORE USE.

The Industrial Aqueous Parts Cleaner is an economical, safe, and innovative system designed to clean parts, using an aqueous based solution. Aqueous solutions, when used to clean grease and oil, must be disposed of properly. Consult your local environmental management agency for additional guidance and other potentially hazardous materials compliance requirements.

Install your parts cleaner on a flat, level surface in an area provided with adequate ventilation. Avoid repeated or prolonged breathing of vapors. Do **NOT** use compressed air to dry parts as this may cause a high concentration of vapors in the immediate area. Local exhaust ventilation should be used in areas of high vapor concentration. Provisions for determining and maintaining adequate ventilation are the responsibility of the operator.

Make sure the parts cleaner is connected to a properly grounded power source. Check serial plate for power requirements.

Do **NOT** allow the parts cleaner to operate unattended.

II. Safety Instructions and Information

Complete safety in use is dependent upon proper use and handling of the parts cleaner in your workplace.

It is important that you follow the instructions provided in this manual. If you fail to read, understand, and follow all of the procedures in this manual, you may cause or suffer personal injury.

DO NOT OPERATE ELECTRICAL EQUIPMENT INSIDE OF PARTS CLEANER.



CAUTION

**USE ONLY WATER-BASED CLEANING SOLUTIONS
DO NOT USE MINERAL SPIRITS**

This equipment is designed for use only with Aqueous Based Solutions. Do **NOT** add any other chemicals to the cleaning agent including, but not limited to, kerosene, fuel oil, gasoline, or chlorinated solutions. The use of any other solutions could potentially cause a hazardous condition.



CAUTION

**DO NOT ALLOW HEATER TO OPERATE UNATTENDED FOR
LONG PERIODS, SUCH AS EVENINGS OR WEEKENDS.**

Avoid contact with eyes or skin. Wear protective eyewear, gloves, and clothing.

Operation should be conducted in a manner, which prevents splashing, or spillage. Any spills should be promptly and properly cleaned up. Soak up all spills with absorbent material. Remove and dispose of all soaked material in accordance with regulatory requirements.

This unit is **NOT** intended for outdoor operation.

Do **NOT** leave solution-soaked rags in parts cleaner or in uncovered containers.

Do **NOT** obstruct the cover. It is designed to close automatically in the event of a fire. The safety link and cover closing mechanism must be intact. Do **NOT** substitute with any other type of cover positioning device. Do **NOT** leave large objects in the parts cleaner or hang anything on the cover that could prevent the cover from closing in the event of a fire.

Do **NOT** place heavy objects on edges or front of sink. Although this parts cleaner is designed to be stable, uneven weight distribution could cause a hazardous condition.

Do **NOT** contaminate cleaning solutions with gasoline, alcohol or flammable liquids.

When cleaning carburetors or other fuel supplying components: remove all gasoline into a proper disposal container before placing the component into the parts cleaner.

Do **NOT** spray aerosols into or around this machine. Install the equipment in an area away from heat, sparks, and open flame. Never put hot parts into the solution.

Do **NOT** use compressed air to dry parts. Be sure parts, especially brake parts, are completely dry prior to reassembly.

Turn unit "OFF" and close lid when equipment is not in use. This will reduce evaporation.

A. Important Safety Instructions

1. Read all instructions.
2. Care must be taken as burns can occur from touching hot parts.
3. Do not operate equipment with a damaged cord or if the equipment has been dropped or damaged – until it has been examined by a qualified service person.
4. If an extension cord is necessary, a cord with a current rating equal to or more than that of the equipment should be used. Cords rated for less current than the equipment may overheat. Care should be taken to arrange the cord so that it will not be tripped over or pulled.
5. Always unplug equipment from electrical outlet when not in use. Never use the cord to pull the plug from the outlet. Grasp plug and pull to disconnect.
6. To reduce the risk of fire, do **NOT** operate equipment in the vicinity of open containers of flammable liquids (gasoline).
7. To reduce the risk of electric shock, do **NOT** use on wet surfaces or expose to rain.
8. Use only as described in this manual. Use only manufacturer's recommended attachments.
9. **ALWAYS WEAR SAFETY GLASSES.** Everyday eyeglasses only have impact resistant lenses, they are not safety glasses.
10. Do **NOT** operate any electrical equipment inside sink or vat.
11. Do **NOT** use light bulbs rated over 40 watts.
12. Do **NOT** smoke, eat or drink in the work area.
13. Do **NOT** modify these machines.
14. Do **NOT** operate this unit in any manner that will cause splashing or cause mist to form.
15. Use only aqueous solution.
16. Adjust flexible nozzle or flow-thru brush so solution is directed to inside the sink only.
17. On the Control box, set the breaker switches to **OFF** before plugging in unit.
18. In any emergency, turn off the unit.
19. These parts washers employ a safety feature called a fusible link that holds the cover open during use. Do **NOT** modify, alter, or obstruct the operation of the fusible link.
20. Keep cover closed whenever unit is not in use.
21. Do **NOT** remove fluid from this equipment or it may cause malfunction or unsafe conditions.

SAVE THESE INSTRUCTIONS

B. Service

Call your representative should your parts cleaner need service and always unplug unit when servicing.

Inspect and keep in good working order the power cord and all electrical components. If components show signs of damage or wear replace immediately. All work should be done by a trained technician.

Do **NOT** replace pump before unplugging unit and letting it completely cool down.

Do **NOT** replace fusible link with any other device to hold lid up. If fusible link should fail, for any reason, call your representative immediately.

C. Fire

This equipment is designed for use only with Aqueous Based Solutions. Do **NOT** add any other chemicals to the cleaning agent including, but not limited to, kerosene, fuel oil, gasoline, or chlorinated solutions. The use of any other solutions could potentially cause a hazardous condition.

Maintain the liquid level within the indicated operating range.

For your protection, a fusible link automatically closes the cover of the parts cleaner in the event that a fire occurs in the sink work area. The closed cover contains and smothers the fire inside the sink. Do **NOT** leave large objects in the parts cleaner or hang anything on the cover that could prevent it from closing in the event of a fire. Do **NOT** replace fusible link with any other device to hold cover up.

IN CASE OF FIRE: Use a Type ABC or Type BC fire extinguisher. Do **NOT** use water. Contact your local fire department.

IN AN EMERGENCY, UNPLUG THE ELECTRICAL SUPPLY TO THE UNIT.

D. First Aid (Medical instructions)

Please note that these First Aid Precautions are for uncontaminated cleaning solutions only. Once the solution has been contaminated (i.e. with oil, grease, antifreeze, etc.), safety precautions should be adjusted according to the type of contaminant.

1. **EYES:** Contact may cause slight to moderate irritation. **For direct contact, flush eyes with water for 10-15 minutes or until the material has been removed; be sure to remove contact lenses, if present, and to lift the upper and lower lids during rinsing. If irritation from vapors or mists develops, move victim into fresh air. Get medical attention if irritation persists.**
2. **SKIN:** Prolonged or repeated contact tends to remove skin oils, possibly leading to dermatitis. **Wash skin with soap and water. Remove contaminated clothing, rinse shoes and launder clothing before reuse. If irritation or pain develops or persists, seek medical attention.**
3. **INHALATION (Breathing):** Prolonged exposure to concentrate-mist or vapor may cause mild irritation of nasal passages or throat. **Remove to fresh air immediately. Do not leave victim unattended. Get medical attention if irritation persists.**

4. Fill solution reservoir to the correct level. This equipment is designed for use only with Aqueous Based Solutions. Do **NOT** add any other chemicals to the cleaning agent including, but not limited to, kerosene, fuel oil, gasoline, or chlorinated solutions. The use of any other solutions could potentially cause a hazardous condition.

Capacity Model EM4000 = 35 gal. (132.5 L.)
Low Level = 27 gal. (102.2 L.)

5. Plug the power cord into a properly grounded power source. Check serial plate for power requirements.

Power Requirements = 15 amp, 115 volt, 60 Hz

IV. Operation

This unit has an automatic low-fluid control sensor. Unit operates on 30-35 gallons (113.6-132.5 L.) or more of fluid. When the fluid level decreases to 27 gallons (102.2 L.), pump will shut off. When this occurs, add 5-7 gallons (18.9-26.5 L.) of fluid to machine to reset low fluid control sensor. This will reactivate the pump.

Thermostat is "PRESET" do **NOT** adjust. Higher temperature could cause damage to skin.

A. Fluid Control Valves

There are three valves used for controlling fluid flow.

1. The spigot valve controls fluid flow to the spigot.
2. The brush valve controls fluid flow to the brush.
3. The agitation valve controls fluid flow to the mechanical agitation assembly.

B. Fluid Filter.

Periodically remove the fluid filter and clean.

1. To remove the fluid filter, slide the perforated plate up until it is free of the slots.
2. Remove the fluid filter from the perforated plate.

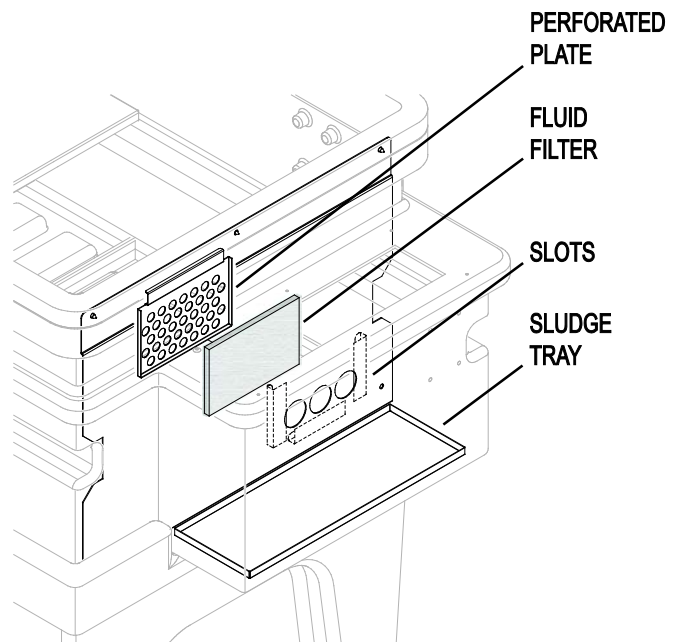

V. Cleaning

A. Cleaning Instructions

1. Turn OFF heater and pump, let cool.
2. Direct spigot into proper storage container.
3. Turn ON pump and liquid level bypass switch, located on rear control box.
4. Pump all fluid from base and dispose of in accordance with applicable local regulations.
5. Turn pump and liquid level bypass switch OFF and unplug unit.
6. Remove stainless steel panel on right hand side of tank basin.
7. Clean excess residue from the bottom of the base.
8. Clean the scale off the heater element with a wire brush. Make sure the thermostat bulb is free from scale.
9. Refill unit.
10. Reinstall stainless steel panel removed in step #6.
11. Plug cord in and turn ON both the heater and pump, make sure that the liquid level bypass switch is OFF.

1	FLO-THRU BRUSH	8169
2	VALVE	13-10164-02
3	FLEX HOSE	13-10164-01
4	SLUDGE TRAY ASSEMBLY	192076
5	INNER SHELF, SLOTTED	192091
6	INNER SHELF	192089
7	FUSIBLE LINK.....	01178
8	DOOR CLOSURE.....	02-10698-250
9	FILTER BRACKET	192097
10	FILTER, 50MIC POLY	8419
11	FILTER HOUSING.....	16-10166
12	POWER CORD.....	8850
13	SWITCH BOOT	12-10153
14	TOGGLE SWITCH.....	12-10147
15	LIQUID LEVEL SENSOR	12-10156
16	PUMP	8870
17	HEATER	12-10148
18	SWITCH ROCKER	12-11143
19	THERMOSTAT	12-10149

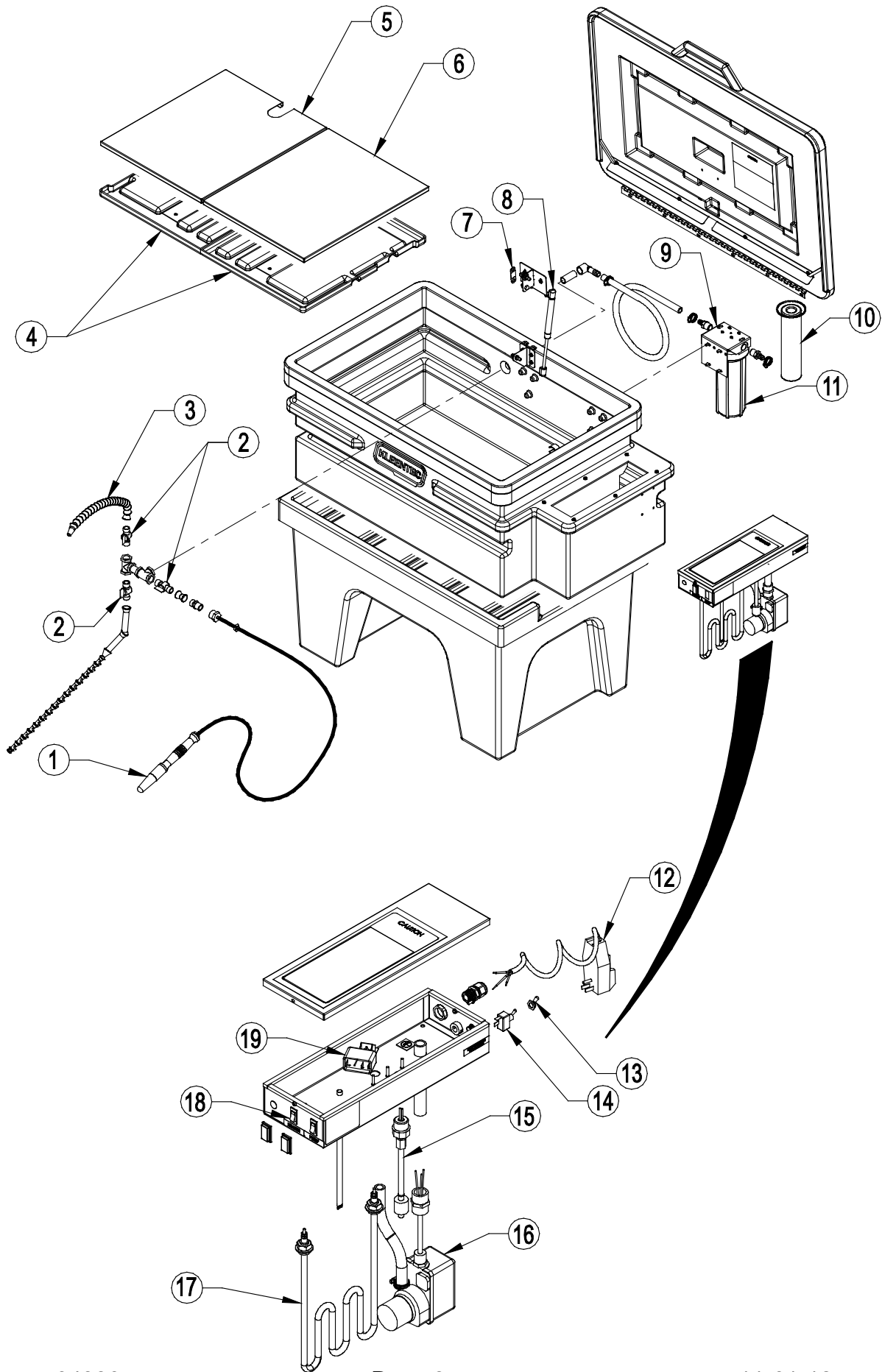

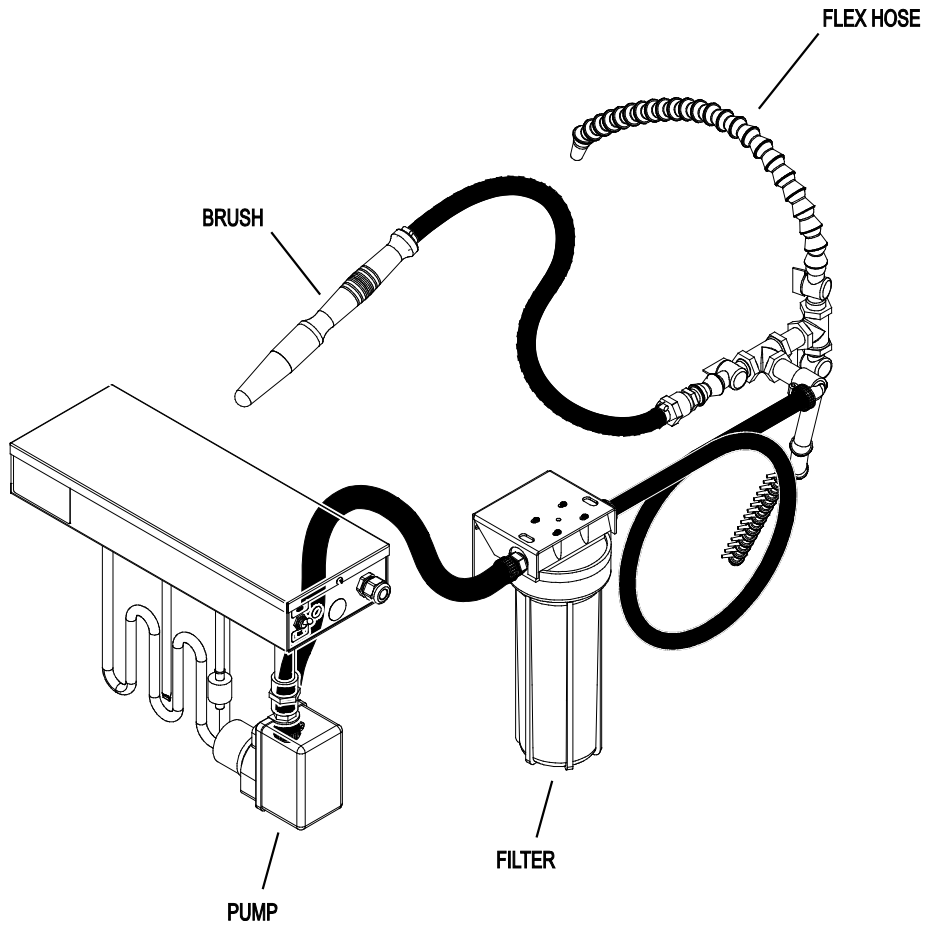

Fluid Flow

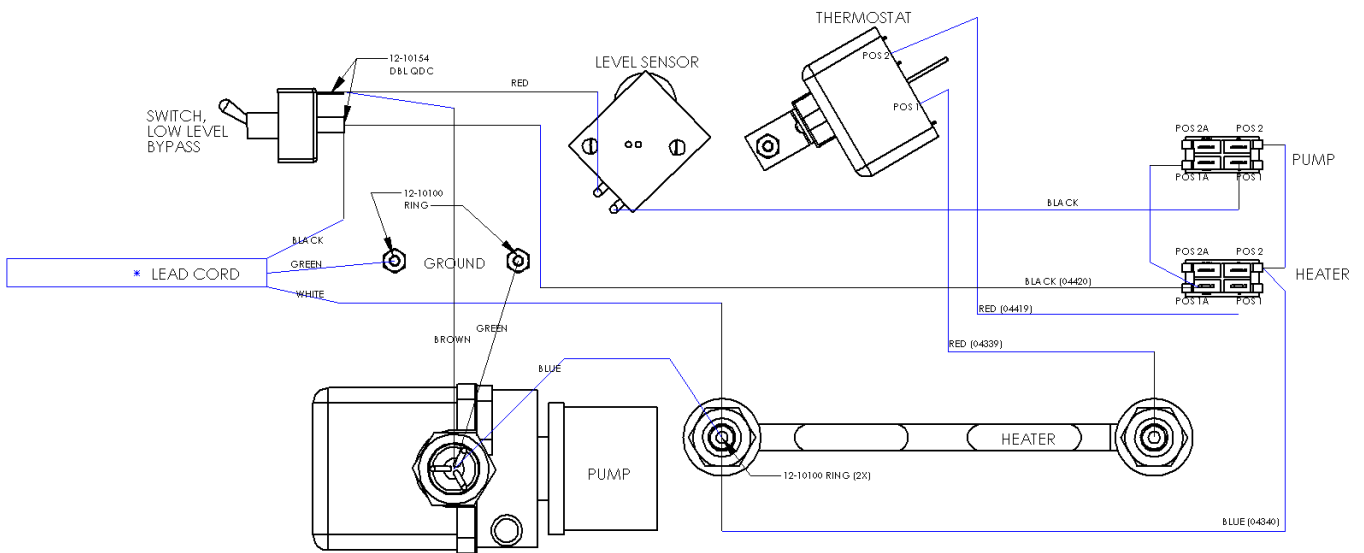

WIRING DIAGRAM

VI. TROUBLESHOOTING

A. Machine does not operate:

1. Make sure the parts cleaner is connected to electric power or air supply.
2. Check for incoming power. Check serial plate for power requirements.
3. On electric units: check reset button on GFCI cord to make sure it is not tripped. On air units: an increase in air supply may be required.

B. Cleaning fluid not to temperature:

1. Check to make sure heater switch is turned "ON".
2. Check fluid level in tank.
3. Check to see if high temperature reset is tripped.

C. Little or no fluid flow thru the flow-thru brush:

1. Turn pump switch "ON" or increase air pressure.
2. Check the fluid level in the tank.
3. Check pump intake for obstructions.

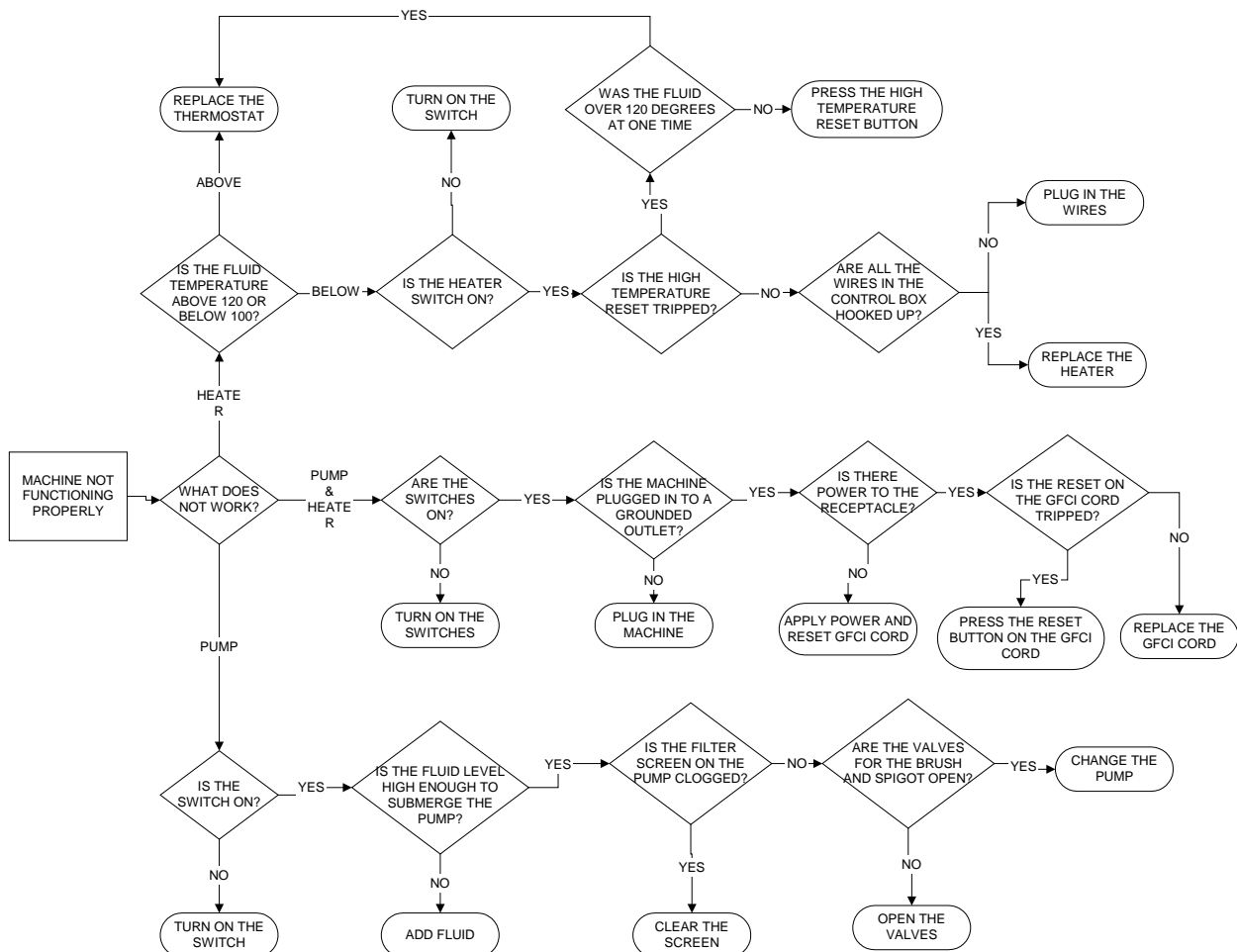

LIMITED WARRANTY AND LIMITATION OF REMEDIES AND DISCLAIMER. (1) Fountain Industries "Fountain" warrants the Equipment to be free from defects in material and manufacture and to conform to specifications for the Equipment at the time of shipment. This warranty is applicable only if the Equipment is installed, operated and maintained in accordance with factory recommendations and procedures. If any Equipment fails to conform to the specifications or samples or any defect in material or manufacture appears within twelve (12) months from the date of initial purchase by end user Fountain's entire liability, and Customer's exclusive remedy, shall be, to either repair or replace such defective Equipment, at Fountain's option, within a reasonable time after written notification thereof and return of the defective Equipment to Fountain.

(2) THIS WARRANTY IS MADE IN LIEU OF ALL OTHER WARRANTIES, EXPRESS OR IMPLIED, INCLUDING, BUT NOT LIMITED TO, THE IMPLIED WARRANTY OF MERCHANTABILITY, THE IMPLIED WARRANTY OF FITNESS FOR A PARTICULAR PURPOSE, ANY IMPLIED WARRANTY ARISING OUT OF COURSE OF DEALING OR OF PERFORMANCE, CUSTOM OR USAGE OF TRADE EXCEPT OF TITLE AND AGAINST PATENT INFRINGEMENT.

(3) LIMITATION OF LIABILITIES; TIME LIMIT FOR FILING ACTION. NEITHER PARTY SHALL UNDER ANY CIRCUMSTANCES BE LIABLE TO EACH OTHER FOR DAMAGES OF ANY KIND, INCLUDING, WITHOUT LIMITATION, DIRECT, INDIRECT, INCIDENTAL, SPECIAL OR CONSEQUENTIAL DAMAGES (INCLUDING, BUT NOT LIMITED TO, LOSS OF PROFITS, REVENUE OR BUSINESS) RESULTING FROM OR IN ANY WAY RELATED TO THE EQUIPMENT, ANY OF CUSTOMER'S PURCHASE ORDERS, THESE TERMS AND CONDITIONS OR THE TERMINATION OR NONRENEWAL THEREOF.

FOUNTAIN'S LIABILITY ON ANY CLAIM OF ANY KIND (INCLUDING NEGLIGENCE) FOR ANY LOSS OR DAMAGE ARISING OUT OF OR RESULTING FROM THIS AGREEMENT, OR FROM THE PERFORMANCE OR BREACH THEREOF, OR FROM THE EQUIPMENT FURNISHED HEREUNDER SHALL IN NO CASE EXCEED THE PRICE OF THE SPECIFIC EQUIPMENT WHICH GIVES RISE TO THE CLAIM. ALL SUCH LIABILITY SHALL TERMINATE UPON THE EXPIRATION OF THE WARRANTY PERIOD AS STATED HEREIN.

This limitation applies regardless of whether such damages are sought based on breach of contract, negligence, strict liability in tort or any other legal theory.

(4) Any action for breach of warranty or any other obligation under these Terms and Conditions must be commenced within one year from the purported date of breach.

(5) Each limitation on liability or remedy set forth in these Terms and Conditions is independent of any other limitation or if they are otherwise held to be unenforceable, that shall not affect the validity of any other such limitation or remedy.

Fountain assumes no liability for any claims for injury or damages to persons or property arising from any chemical manufactured by Customers or by third party vendors for use in Fountain's equipment.

Terms or conditions contained in any Customer purchase order or similar document that in any manner purport to alter, modify, change, or suspend these terms shall be deemed excluded from such purchase order and waived by the Customer.

This limited warranty does not cover or include consumable/wearable associated with such equipment.

Fountain assumes no liability for any unauthorized modifications carried out to the equipment not strictly recommended by the factory procedures.

This limited warranty is not transferable, and does not cover general equipment maintenance, demonstration, installation, routine servicing, calibration or customization of the equipment.

No person is authorized to alter or extend this limited warranty unless made in writing and signed by an authorized officer of Fountain.



Fountain Industries LLC
922 East 14th St.
Albert Lea, MN 56007

Tel: 800-328-3594
507-373-2351
Fax: 507-373-7404

Email: CUSTSERV@FOUNTAININDUSTRIES.COM
WWW.FOUNTAININDUSTRIES.COM