



1400-Lb. Capacity Jumbo Wagon
Owner's Manual



WARNING:

Read carefully and understand all **INSTRUCTIONS** before operating. Failure to follow the safety rules and other basic safety precautions may result in a serious personal injury.

Item #46438

Thank you very much for choosing a Strongway™ product! For future reference, please complete the owner's record below:

Model: _____ Purchase Date: _____

Save the receipt, warranty and these instructions. It is important that you read the entire manual to become familiar with this product before you begin using it.

This machine is designed for certain applications only. The distributor strongly recommends that you do not modify or use this wagon for any application other than that for which it was designed. If you have any questions relative to a particular application, DO NOT use the wagon until you have first contacted the distributor to determine if it can or should be performed on or with this product.

For technical questions and replacement parts, please call 1-800-222-5381.

INTENDED USE

Strongway's Industrial-grade Jumbo Wagon handles heavy loads up to 1400 lb. It's perfect for hauling patio blocks, firewood, gardening supplies, and much more. The front, rear, and side panels fold away or detach completely for easy loading and unloading.

SPECIFICATIONS

Item#	46438
Capacity	1,400 lb.
Frame Material	Steel
Wheel Type	Pneumatic
Dimensions L x W x H (inches)	50 x 24 ^{7/32} x 26 ^{3/4}

GENERAL SAFETY REGULATIONS

 **WARNING:** Read and understand all instructions. Failure to follow all instructions listed below may

result in serious bodily injury or death and/or property damage.

⚠️ WARNING: The warnings, cautions, and instructions discussed in this instruction manual cannot cover all possible conditions or situations that could occur. It must be understood by the operator that common sense and caution are factors that cannot be built into this product but must be supplied by the operator.

- **Inspect work area.** Ensure your work area is free and clear of any electrical, chemical, or environmental hazards.
- **Keep children away from work area.** Do not allow children to handle this product.
- **Always wear ANSI-approved safety glasses and heavy-duty work gloves during assembly and use.** Do not wear loose clothing or jewelry, which can get caught in moving parts.
- **Store idle equipment.** When not in use, tools and equipment should be stored in a dry location to inhibit rust. Always lock up tools and equipment, and keep out of the reach of children.
- **Use the right tool for the job.** Do not attempt to force small equipment to do the work of larger industrial equipment. There are certain applications for which this equipment was designed. It will do a better job and more safely at the capacity for which it was intended. Do not modify this equipment, and do not use this equipment for a purpose for which it was not intended.
- **Check for damaged parts.** Before using this wagon, carefully check that it will operate properly and perform its intended function. Check for damaged parts and any other conditions that may affect the operation of this wagon. Replace damaged or worn parts immediately.
- **Do not overreach.** Keep proper footing and balance at all times to prevent tripping, falling, back injury, etc.
- **DO NOT use the equipment when tired or under the influence of drugs, alcohol, or medication.** A moment of inattention while operating this equipment may result in serious personal injury.
- **Industrial applications must follow OSHA requirements.**

GUIDE TO SAFE OPERATION

⚠️ WARNING: The wagon must only be used to carry goods. Do not use the wagon as personal transportation.

- **MAX LOAD: 1400 LB. NEVER OVERLOAD THIS WAGON.**
- **DO NOT inflate tires to more than 40 psi.**
- **DO NOT operate if any part is damaged or loose.**
- **Lower the fence rails when loading large items onto cart.**
- **Distribute the load evenly in the wagon's bed.**
- **When loading and unloading the wagon, be careful of the balance of the wagon. Always be careful of the handle, which can tip and fall from the upright position.**
- **Always block the four wheels when loading or unloading the wagon.**
- **Do not allow children to use this wagon. It is not a toy.**
- **Ensure that the load is securely fastened within the bed of the wagon.**

ASSEMBLY INSTRUCTIONS

Before assembling, be sure all parts and hardware mentioned in this manual are included in the package. See Fig. 1.

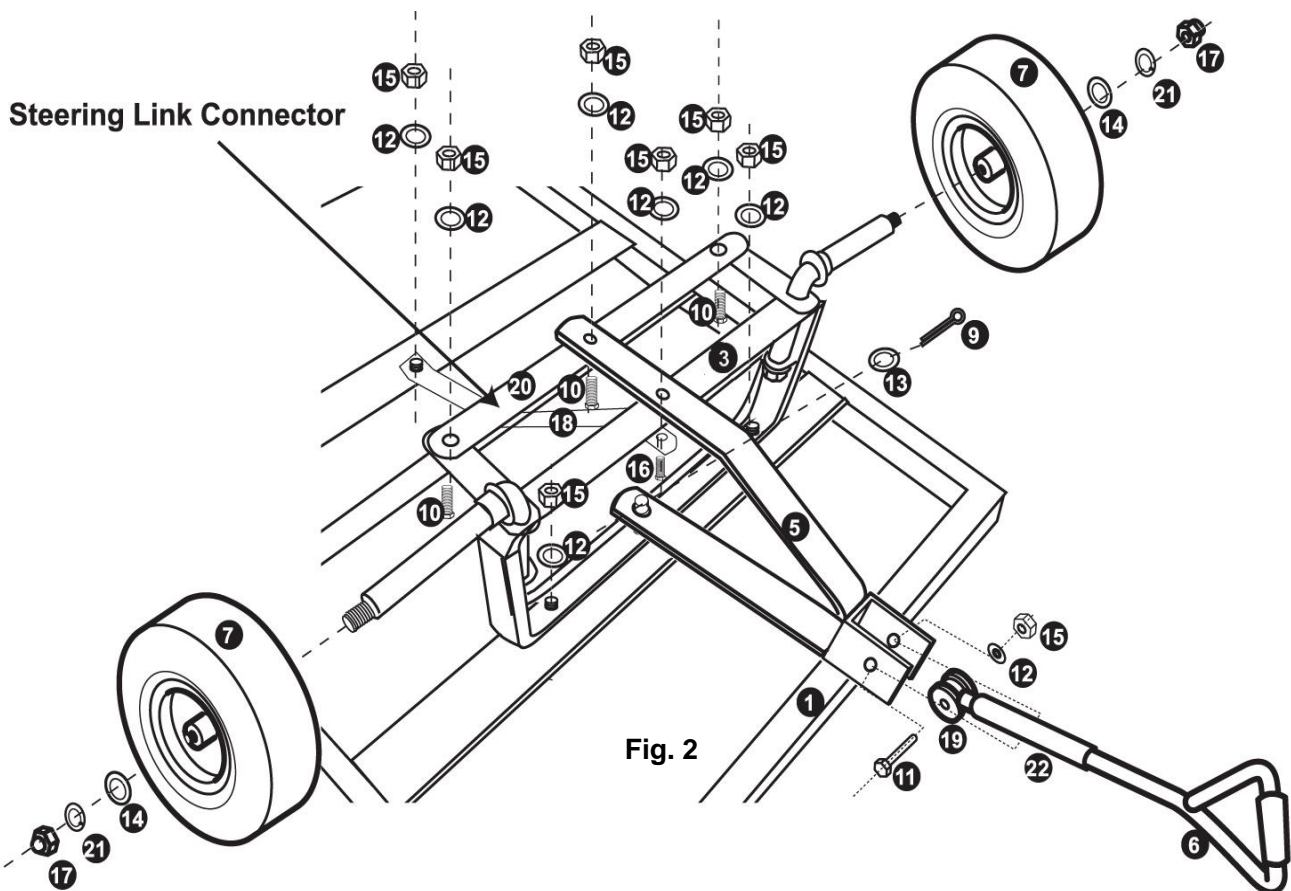

Fig. 1

NOTE: Do not completely tighten screws until the assembly is complete. For easier assembly, we recommend using two people to assemble this product.

STEP 1: Install Front Axle Support, Front Wheels and Handle (See Fig. 2)

1. Remove the cardboard from the shipping carton and place the cart Bed (part #1) onto the cardboard to keep it from scratching or causing other surface damage.
2. Turn the cart Bed (part #1) upside down, so that the exposed screw holes can be seen.
3. Hold up the foldable Front Axle Support (part #3) to line up the holes on the Bed (part #1) and lock it with a Hex Nut (part #15) and Washer (part #12).
4. Assemble the Steering Link Connector (part #20) onto the Front Axle Support (part #3) with a Nut (part #15), Bolt (part #10), and Washer (part #12). Hand tighten.
5. Slide the Wheel (part #7) into the Axle with the valve stem facing out. Using a Washer (parts #14 & #21) and Convex Nut (part #17) to fasten the Wheel (part #7).
6. Place the Yoke (part #5) on the Front Axle Support (Part #3). Place the short side of the Yoke (part #5) onto the center stud of the Front Axle Support (part #3). Use one Lock Pin (part #9) and Washer (part #13) to fasten it. Place the long side of the Yoke (part #5) onto the Front Axle Support (part #3) and Steering Link Connector with a Bolt (part #10) and Nut (part #15).
7. Assemble the Center Front Axle Brace (part #18) onto the Bed (part #1) and the Front Axle Support (part #3) with a Nut (part #15) and Washer (part #12) then fasten.
8. Place the Handle (part #6) and Plastic Coupling (part #19) onto the Yoke (part #5) using a Bolt (part #11), Washer (part #12), and Nut (part #15).



STEP 2: Install Rear Axle Support and Rear Wheels. See Fig. 3.

1. Turn the foldable Rear Axle Support (part #4) 90 degrees and lock it with a Hex Nut (part #15) and washer (part #12).
2. Assemble the Center Front Axle Brace (part #18) onto the Bed (part #1) and axle on the Rear Axle Support (part #4) using a Nut (part #15) and Washer (part #12), then tighten.
3. Slide the Wheel (part #7) into the Axle with the valve stem facing out using a Washer (parts #14 & #21) and Convex Nut (part #7) to fasten the Wheel (part #7).

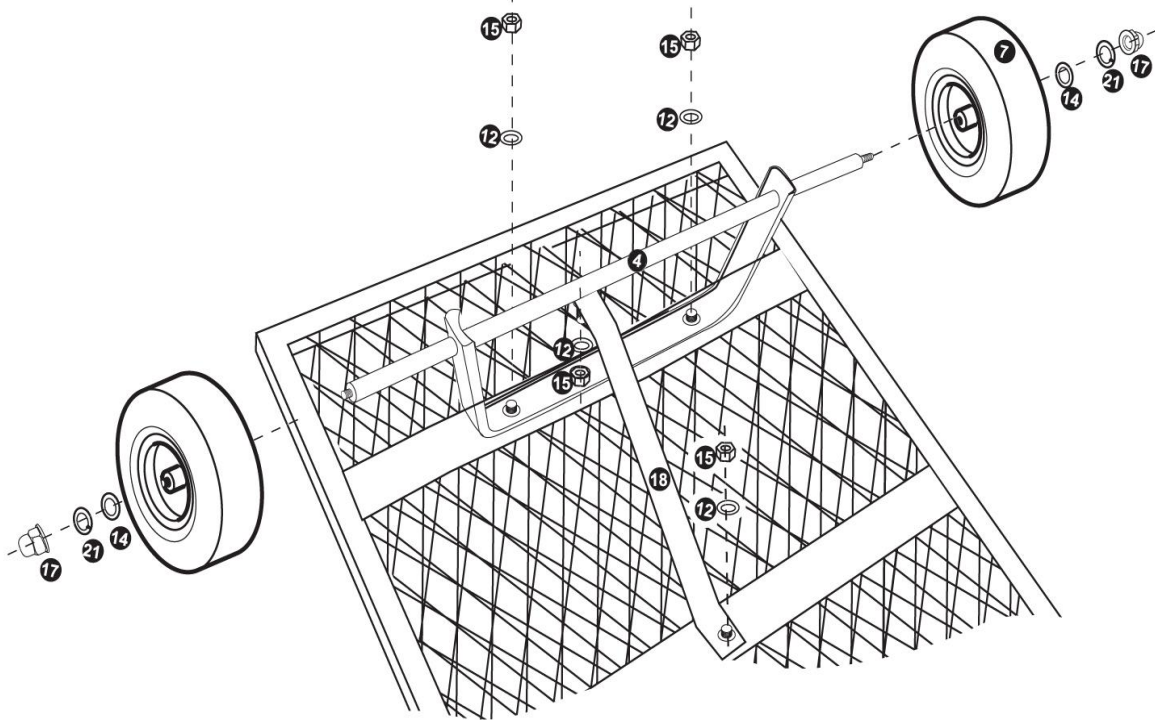

STEP 3: Install Fences. See Fig. 4.

Fig. 3

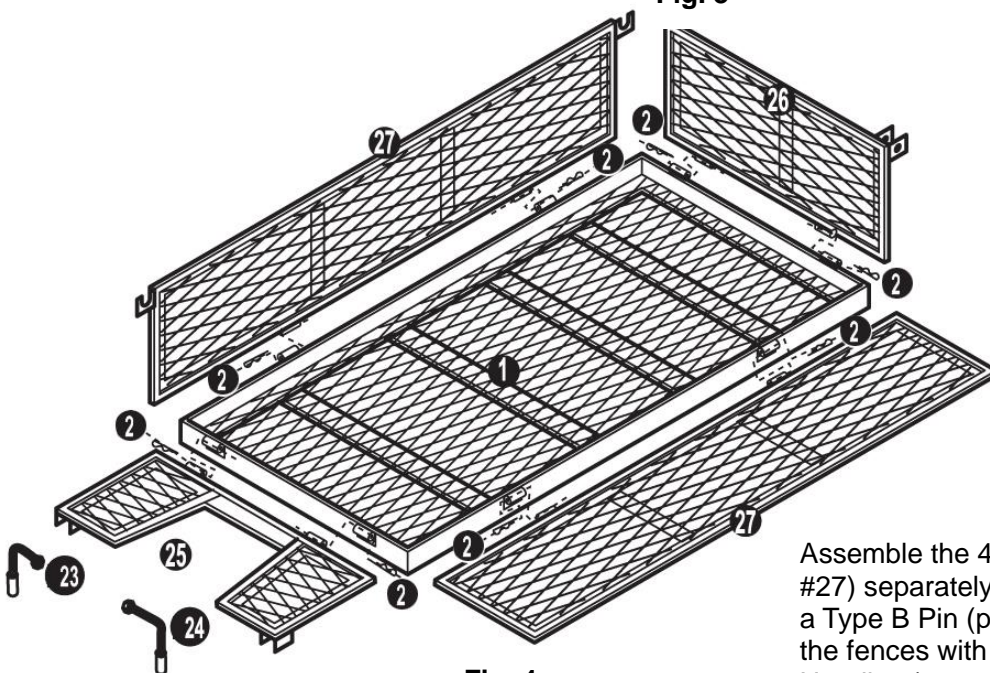

Fig. 4

Assemble the 4 fences (parts #25, #26, #27) separately on the Bed (part #1) with a Type B Pin (part #2), then connect all the fences with Left and Right Lock Handles (parts #23 & 24).

MAINTENANCE

1. Lubricate the steering handles before use for easy operation.
2. When not in use, store the wagon in a dry place, out of direct sunlight.
3. Periodically check the tire pressure. The tire pressure should be no more than 40 psi.
4. Periodically check the hardware. Retighten if any hardware is loose.

EXPLODED VIEW & PART LIST

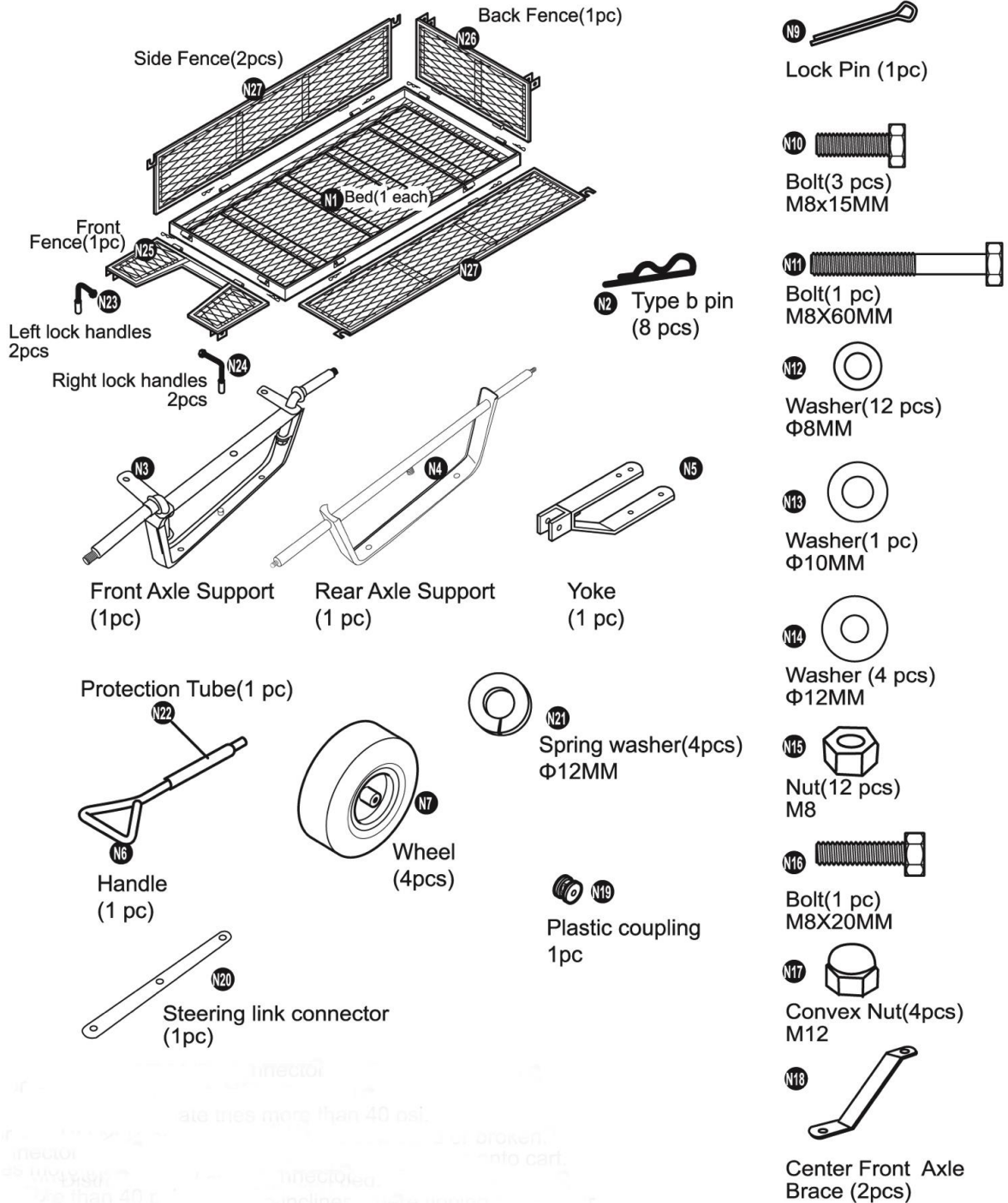

For technical questions and replacement parts, call **1-800-222-5381**.

WARRANTY

One-Year Limited Warranty



Distributed by:
Northern Tool + Equipment Co., Inc.
Burnsville, MN 53306-6936
www.NorthernTool.com
Made in China