



COMPACT RIGHT ANGLE DRILL

OWNER'S MANUAL



WARNING:

Read carefully and understand all **ASSEMBLY AND OPERATION INSTRUCTIONS** before operating. Failure to follow the safety rules and other basic safety precautions may result in serious personal injury.

Item# 45985

Thank you very much for choosing an Ironon product! For future reference, please complete the owner's record below:

Model: _____ Purchase Date: _____

Save the receipt, warranty and these instructions. It is important that you read the entire manual to become familiar with this product before you begin using it.

This machine is designed for certain applications only. The distributor cannot be responsible for issues arising from modification. We strongly recommend this machine not be modified and/or used for any application other than that for which it was designed. If you have any questions relative to a particular application, DO NOT use the machine until you have first contacted the distributor to determine if it can or should be performed on the product.

For technical questions please call **1-800-222-5381**.

INTENDED USE

This Compact Right Angle Drill is designed for drilling between studs and joints.

TECHNICAL SPECIFICATIONS

Voltage /Frequency:	120V / 60Hz
Power:	8 Amp
Rated running speed:	340 and 1375 RPM
Chuck size capacity:	1/8 in. to 1/2 in. Shank Diameter Drill Bits

GENERAL SAFETY RULES



WARNING: Read and understand all instructions. Failure to follow all instructions listed below may result in serious injury.



CAUTION: Do not allow persons to operate or assemble this Compact Right Angle Drill until they have read this manual and have developed a thorough understanding of how the Compact Right Angle Drill works.



WARNING: The warnings, cautions, and instructions discussed in this instruction manual cannot cover all possible conditions or situations that could occur. It must be understood by the operator that common sense and caution are factors that cannot be built into this product, but must be supplied by the operator.

SAVE THESE INSTRUCTIONS

IMPORTANT SAFETY CONSIDERATIONS

WORK AREA

- Keep your work area clean and well lit. Cluttered and dark work areas invite accidents.
- Do not operate power tools in explosive atmospheres, such as in the presence of flammable liquids, gases, or dust. Power tools create sparks, which may ignite the dust or fumes.
- Keep bystanders, children, and visitors away while operating a power tool. Distractions can cause you to lose control.

ELECTRICAL SAFETY



WARNING: Always check to ensure the power supply corresponds to the voltage on the rating plate.

- Grounded tools must be plugged into an outlet properly installed and grounded in accordance with all codes and ordinances. Never remove the grounding prong or modify the plug in any way. Do not use any adapter plugs. Check with a qualified electrician if you are in doubt as to whether the outlet is properly grounded. If the tools should electrically malfunction or break down, grounding provides a low resistance path to carry electricity away from the user.
- Avoid body contact with grounded surfaces such as pipes, radiators, ranges, and refrigerators. There is an increased risk of electric shock if your body is grounded.
- Do not expose power tools to rain or wet conditions. Water entering a power tool will increase the risk of electric shock.
- Do not abuse the power cord. Never use the power cord to carry the tools or pull the plug from an outlet. Keep the power cord away from heat, oil, sharp edges or moving parts. Replace damaged power cords immediately. Damaged power cords increase the risk of electric shock.
- When operating a power tool outside, use an outdoor extension cord marked “W-A” or “W.” These cords are rated for outdoor use and reduce the risk of electric shock.
- Do not expose power tools to rain or wet conditions. Water entering a power tool will increase the risk of electric shock.
- Do not let your fingers touch the terminals of plug when installing or removing from the outlet.
- Ground fault circuit interrupters. If work area is not equipped with a permanently installed Ground Fault Circuit Interrupter outlet (GFCI), use a plug-in GFCI between power tool or extension cord and power receptacle.

PERSONAL SAFETY

- Stay alert. Watch what you are doing and use common sense when operating a power tool. Do not use a power tool while you are tired or under the influence of drugs, alcohol or medication. A moment of inattention while operating power tools may result in serious personal injury.
- Dress properly. Do not wear loose clothing, dangling objects, or jewelry. Keep your hair, clothing and gloves away from moving parts. Loose clothes, jewelry or long hair can be caught in moving parts. Air vents often cover moving parts and should be avoided.
- Avoid accidental starting. Be sure the power switch is off before plugging in. Carrying power tools with your finger on the power switch, or plugging in power tools with the power switch on, invites accidents.

- Remove adjusting keys or wrenches before turning the power tool on. A wrench or a Remove adjusting keys or wrenches before turning the power tool on. A wrench or key that is left attached to a rotating part of the power tool may result in personal injury.
- Do not overreach. Keep proper footing and balance at all times. Proper footing and balance enables better control of the power tool in unexpected situations.
- Use safety equipment. Always wear eye protection. Nonskid safety shoes, hard hat, or hearing protection must be used for appropriate conditions. Always wear ANSI-approved safety impact goggles and thick rubber boots during use and maintenance.

GROUNDING



WARNING: Improperly connecting the grounding wire can result in the risk of electric shock. Check with a qualified electrician if you are in doubt as to whether the outlet is properly grounded. Do not modify the power cord plug provided with the tool. Never remove the grounding prong from the plug. Do not use the tool if the power cord or plug is damaged. If damaged, have it repaired by a service facility before use. If the plug will not fit the outlet, have a proper outlet installed by a qualified electrician.

GROUNDING TOOLS: TOOLS WITH THREE-PRONG PLUGS

1. Tools marked with “Grounding Required” have a three-wire cord and three-prong grounding plug. The plug must be connected to a properly grounded outlet. If the tool should electrically malfunction or break down, grounding provides a low resistance path to carry electricity away from the user, reducing the risk of electric shock. (See Fig. A)

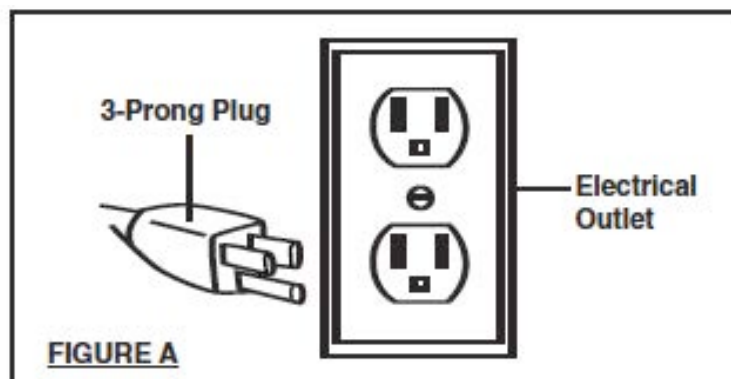

2. The grounding prong in the plug is connected through the green wire inside the cord to the grounding system in the tool. The green wire in the cord must be the only wire connected to the tool’s grounding system and must never be attached to an electrically “live” terminal. (See Fig. A)
3. Your tool must be plugged into an appropriate outlet, properly installed and grounded in accordance with all codes and ordinances. The plug and outlet should look like that in the following illustration. (See Fig. A)

EXTENSION CORDS

1. Grounded tools require a three-wire extension cord.
2. As the distance from the supply outlet increases, you must use a heavier gauge extension cord. Using extension cords with inadequately sized wire causes a serious drop in voltage, resulting in loss of power and possible tool damage. (See Fig. B next page)
3. The smaller the gauge number of the wire, the greater the capacity of the cord. For example, a 14-gauge cord can carry a higher current than a 16 gauge cord. (See Fig. B.)

4. When using more than one extension cord to make up the total length, make sure each cord contains at least the minimum wire size required. (See Fig. B.)
5. If you are using one extension cord for more than one tool, add the nameplate amperes and use the sum to determine the required minimum cord size. (See Fig. B.)
6. If you are using an extension cord outdoors, make sure it is marked with the suffix “W-A” (“W” in Canada) to indicate it is acceptable for outdoor use.
7. Make sure your extension cord is properly wired and in good electrical condition. Always replace a damaged extension cord or have it repaired by a qualified electrician before using it. Protect your extension cords from sharp objects, excessive heat, and damp or wet areas.



RECOMMENDED MINIMUM WIRE GAUGE FOR EXTENSION CORDS* (120 VOLT)					
NAMEPLATE AMPERES (At Full Load)	EXTENSION CORD LENGTH				
	25 FEET	50 FEET	75 FEET	100 FEET	150 FEET
0-2.0	18	18	18	18	16
2.1-3.4	18	18	18	16	14
3.5-5.0	18	18	16	14	12
5.1-7.0	18	16	14	12	12
7.1-12.0	16	14	12	10	-
12.1-16.0	14	12	10	-	-
16.1-20.0	12	10	-	-	-

*Based on limiting the line voltage drop to five volts at 150% of the rated amperes.

FIGURE B

COMPACT RIGHT ANGLE DRILL USE AND CARE

- **Do not modify the Compact Right Angle Drill in any way.** Unauthorized modification may impair the function and/or safety and could affect the life of the equipment. There are specific applications for which the Compact Right Angle Drill was designed.
- **Always check of damaged or worn out parts before using the Compact Right Angle Drill.** Broken parts will affect the Compact Right Angle Drill operation. Replace or repair damaged or worn parts immediately.
- **Store idle Compact Right Angle Drill.** When Compact Right Angle Drill is not in use, store it in a secure place out of the reach of children. Inspect it for good working condition prior to storage and before re-use.
- Maintain a safe working environment. Keep the work area well lit. Make sure there is adequate surrounding workspace. Always keep the work area free of obstructions, grease, oil, trash, and other debris. Do not use the Drill in areas near flammable chemicals, dusts, and vapors.
- Maintain labels and nameplates on the Drill. These carry important information. If unreadable or missing, contact the distributor for a replacement.

- Use the right product for the right job. There are certain applications for which this product was designed. Do not use small equipment, tools, or attachments to do the work of larger industrial equipment, tools, or attachments. Do not use this product for a purpose for which it was not intended.
- Wear ANSI-approved safety impact eye goggles underneath an approved safety impact full face shield. Also use approved hearing protection and heavy-duty work gloves. If necessary, wear an approved dust mask or respirator.
- Industrial applications must follow OSHA requirements.
- When using the drill, always maintain a firm grip on the tool with both hands.
- Do not handle the drill with wet hands.
- Avoid unintentional starting. Make sure you are prepared to begin work before turning on the drill.
- Never leave the drill unattended when it is plugged into an electrical outlet. Turn off the drill, and unplug it from its electrical outlet before leaving.
- Prior to drilling into a wall, floor, etc., make sure no hidden electrical wiring, cables, the drill's own power cord, or other obstructions are in the drilling path.
- Keep the handles of the drill in their proper place, clean and oil/grease free, and in proper adjustment and alignment.
- Do not force the tool. This product will do the job better and safer at the speed and capacity for which it is designed.
- Never use your body to brace the drill. Never put your hands, or other body parts, between the part of the drill being braced and the object it is being braced against. Hands, or other body parts, that are in the direct path of a twisting reaction can be pinched, crushed and broken.
- When drilling with a single speed drill or in "HIGH" with a two-speed drill, always hold the drill securely using the Front Handle (15), or brace the drill against a solid fixed object in preparation for a sudden twisting reaction. Also, when drilling in "LOW" with a two-speed drill, always brace the drill against a solid fixed object in preparation for a sudden twisting reaction.
- Always turn off the drill and disconnect the tool from its electrical outlet before moving the tool, changing drill bits, or performing any service or maintenance.
- Safely store the drill. When the drill is not in use, it should be unplugged from its electrical outlet and stored in a location that is out of reach of children and unauthorized personnel.
-  **WARNING:** People with pacemakers should consult their physician(s) before using this product. Operation of electrical equipment in close proximity to a heart pacemaker could cause interference or failure of the pacemaker.
-  **WARNING:** Some dust created by compacting materials, power sanding, sawing, grinding, drilling, and other construction activities, contain chemicals known (to the State of California) to cause cancer, birth defects or other reproductive harm. Some examples of these chemicals are: lead from lead-based paints, crystalline silica from bricks and cement or other masonry products, arsenic and chromium from chemically treated lumber. Your risk from these exposures varies, depending on how often you do this type of work. To reduce your exposure to these chemicals: work in a well ventilated area, and work with approved safety equipment, such as those dust masks that are specially designed to filter out microscopic particles.

-  **WARNING:** The warnings, precautions, and instructions discussed in this manual cannot cover all possible conditions and situations that may occur. The operator must understand that common sense and caution are factors that cannot be built into this product, but must be supplied by the operator.



ASSEMBLY

NOTE: For additional information regarding the parts discussed in the following pages, refer to the parts diagram.

Proper Drill Bit Selection:

1. This drill is designed to accept drill bits (not included) from 7/64" to 5/8" cutting diameter (with a bit shank diameter from 1/8" to 1/2"). Do not attempt to use drill bits larger than the capacity of this drill, as damage to the gears and/or motor overload may result.
2. Always use a drill bit that is designed for your specific drilling job. The information contained on the packaging of a drill bit typically indicates for what specific drilling job the drill bit is designed.
3. Always keep drill bits clean and sharp for better and safer performance.

To Install Drill Bits:

1.  **WARNING:** Always make sure the power switch (69) of the drill is in its "OFF" position and that the tool is unplugged from its electrical outlet before installing drill bits.
2. Insert the chuck key (24) into the chuck (43), and turn the chuck key counter clockwise to open the jaws of the chuck (43) wide enough to insert the drill bit. Make sure the shank of the drill bit and jaws of the chuck are clean. Dirt particles may prevent the drill bit from seating properly in the chuck.
3. Insert the shank of the drill bit into the chuck, and turn the chuck key clockwise to secure the drill bit in the chuck.
4.  **CAUTION!** Make sure to remove the chuck key (24) from the chuck (43) prior to turning on the drill.

The Side Handle And Front Handle:

1.  **WARNING:** Always make sure the power switch (69) of the drill is in its "OFF" position and that the tool is unplugged from its electrical outlet before adjusting the side handle (21) and front handle (15).
2. The side handle (21) can be attached to either side of the drill by threading the side handle into one of the threaded mounting holes in the housing (50). (See Fig. C)

3. The front handle (15) can be attached to the drill in three different positions (see I , II , and III positions in Fig. D) . To do so, remove the two bolts (17). Then remove the front handle. Place the front handle in the desired position, and replace the two bolts. NOTE: To attach the front handle in position III, you must turn the front handle around. (See Fig. D).



OPERATION

The Speed Switch Lever:

1. The speed switch Lever (34) is located on the right side of the housing (50). (See Fig. E)
2. The “HIGH” setting on the speed switch Lever (34) runs the drill at 0 to 1,375 RPM. (See Fig. E)
3. The “LOW” setting on the speed switch Lever (34) runs the drill at 0 to 340 RPM. (See Fig. E)
4. **IMPORTANT:** When changing speeds always turn the power switch (69) to its “OFF” position, then set the speed switch lever (34) while the drill is coasting to a stop. Do not set the speed switch lever while the drill is running full speed, running under a load, or when the tool is completely stopped. Failure to follow this procedure can result in serious damage to the drill’s internal gears.

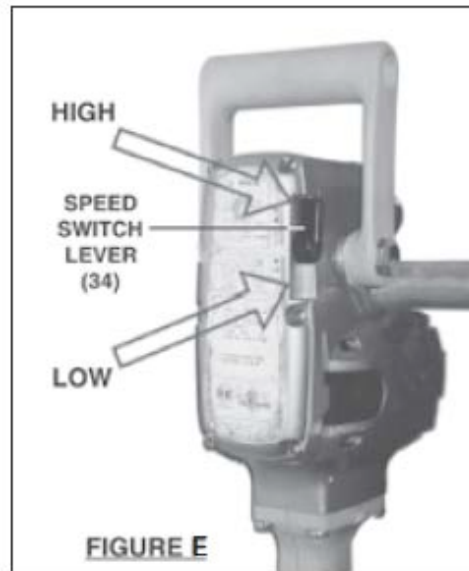

The Power Switch/Reversing Switch:

1. To turn on the drill, squeeze the power switch (69) which is located on the left rear handle (68). To turn off the drill, release pressure on the power switch.
2. The reversing switch (69) is located below the power switch, and is used to remove stuck drill bits from holes. **IMPORTANT:** Do not use the reversing switch when the drill is moving in a forward (clockwise) rotation. Doing so can cause serious damage to the internal gears of the drill. Wait until the drill is completely stopped, then use the reversing switch.

Drilling A Workpiece:

1.  **CAUTION!** Use clamps (not included) or other practical ways to secure and support a smaller workpiece to a stable platform. Holding the work by hand or against your body is unstable and may lead to loss of control.

2.  **WARNING:** If drilling into a wall, floor surface, etc., make sure no hidden electrical wiring, cables, the drill's own power cord, or other obstructions are in the drilling path.

3. To prevent damage when drilling into thin wood stock or light gauge metal, place a block of scrap wood behind the workpiece.

4. Install a drill bit in the chuck (43). Secure the drill bit in the chuck with the chuck key (24). Then, make sure to remove the chuck key (24).

5. Plug the power plug (74) into the nearest 120-volt, grounded, electrical outlet.

6. When using the drill, always maintain a firm grip on the tool with both hands as torque from the drill's motor will cause the drill to twist.

7. Make sure the drill bit lightly touches the point on the workpiece where the hole is to be drilled prior to squeezing the power switch (69) of the drill.

8. While the drill is running, apply light downward pressure on the drill. Do not attempt to force the drill to cut faster than it was designed to cut.

9.  **CAUTION!** Always be prepared for a sudden twisting reaction of the drill. Never place your hands, or other body parts, between the part of the drill being braced and the object it is being braced against. Hands, or other body parts, that are in the direct path of a twisting reaction can be pinched, crushed and broken. Minimize the chances of a sudden twisting reaction by: using the

proper drill bit for the job, using sharp drill bits, setting the speed switch Lever (34) to the proper speed for the size of drill bit, avoiding knotty, warped, or wet workpieces, and avoiding hidden nails or other objects in the workpiece. (See Fig. F)

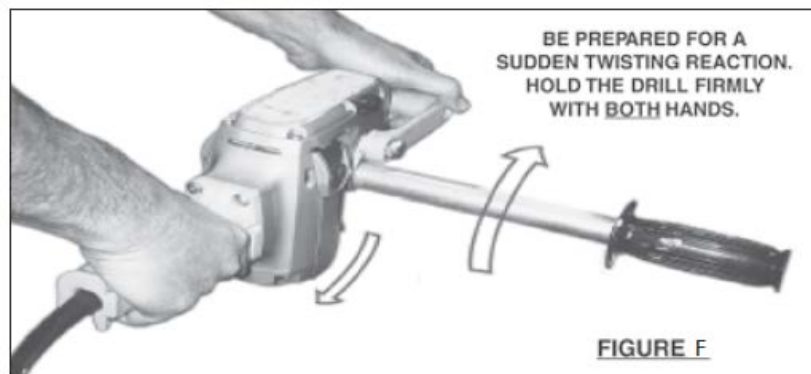

10. As soon as the drill bit cuts completely through the workpiece, remove the drill bit from the hole while the drill is still running. This helps keep the drill bit from becoming jammed in the hole.

11. Release pressure on the power switch (69) to stop the drill, and unplug the drill from its electrical outlet. Remove the drill bit. Then store the drill in a clean, dry, safe location.

MAINTENANCE

- **Maintain your Compact Right Angle Drill.** It is recommended that the general condition of any Compact Right Angel Drill be examined before it is used. Keep your Compact Right Angle Drill in good repair by adopting a program of conscientious repair and maintenance. Have necessary repairs made by qualified service personnel.



WARNING: Always make sure the power switch (69) is in its “OFF” position, and disconnect the drill from its electrical outlet before performing any inspection, maintenance, or cleaning.

- Before each use, inspect the general condition of the drill. Check for loose screws, misalignment or binding of moving parts, cracked or broken parts, damaged power cord (74), loose, dull, or bent drill bits, and any other condition that may affect the safe operation of the drill. If abnormal noise or vibration occurs, have the problem corrected before further use. Do not use damaged equipment.
- Daily: With a soft brush, cloth, or vacuum, remove all dust and debris from the drill. Then, use a premium quality, lightweight machine oil to lubricate all moving parts. Do not immerse any part of the drill in liquids.
- To replace the motor carbon brushes: It may become necessary at sometime to replace the two carbon brushes (19) when the motor performance decreases, or stops working completely. The carbon brushes are located on each side of the housing (50). To do so, remove the two brush caps (20). Then remove the carbon brush from the right brush holder (18), and remove the carbon brush from the left brush holder (70). If the carbon brushes are worn down more than 1/2, replace both carbon brushes. If, however, the carbon brushes are just dirty they may be cleaned by rubbing them with a pencil eraser. When installing the carbon brushes, make sure the carbon portion of the carbon brushes contact the motor armature, and that the springs face away from the motor. Also, make sure the springs operate freely. After cleaning or replacement, replace the brush caps.
- After approximately six months to one year (depending on use) return the drill to a qualified service technician for the following: A thorough mechanical inspection and cleaning of the internal gears, spindles, bearings, housing, etc. A thorough inspection of the power switch, power cord and plug, and motor armature. A thorough testing procedure to ensure proper mechanical and electrical operation.
- When storing, always keep the drill in a clean, dry, safe location out of reach by children and other unauthorized personnel.

DIAGRAM AND PARTS LIST

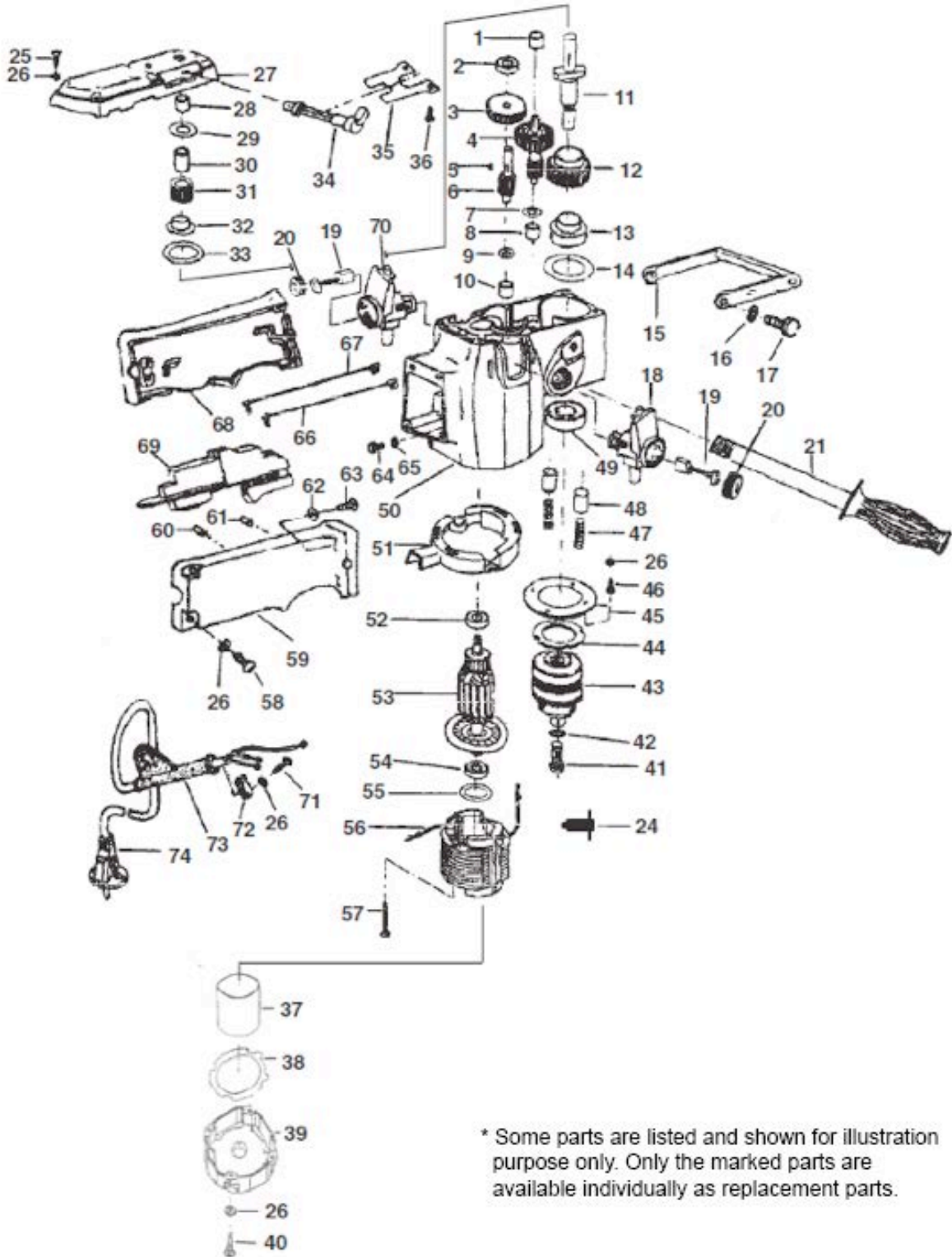

* Some parts are listed and shown for illustration purpose only. Only the marked parts are available individually as replacement parts.

NO.	Part Name	QT	NO.	Part Name	QT
1	Needle Bearing	1	39	Lower Cover	1
2	Roller Bearing	1	40	Screw	4
3	Gear*	1	41	Screw*	1
4	Gear*	2	42	Washer*	1
5	Key*	1	43	Chuck*	1
6	Gear*	1	44	Washer	1
7	Washer*	1	45	Plate	4
8	Needle Bearing	1	46	Screw	2
9	Washer*	1	47	Spring	2
10	Needle Bearing	1	48	Spring Sleeve	1
11	Spindle	1	49	Roller Bearing	1
12	Gear*	1	50	Housing	1
13	Bushing	1	51	Stator Bushing	1
14	Thrust Needle Bearing	1	52	Roller Bearing	1
15	Front Handle*	2	53	Armature	1
16	Washer	2	54	Roller Bearing	1
17	Bolt	2	55	Spring Lock Washer	1
18	Right Carbon Brush Holder*	1	56	Stator	2
19	Carbon Brush*	2	57	Self-Tapping Screw	1
20	Brush Cap*	1	58	Screw	3
21	Side Handle*	1	59	Right Rear Handle	1
24	Chuck Key*	1	60	Cylinder Pin	1
25	Screw	6	61	Cylinder Pin	1
26	Washer	19	62	Washer	1
27	Top Cover	1	63	Screw	4
28	Needle Bearing	1	64	Screw	4
29	Thrust Needle Bearing	1	65	Washer	1
30	Bushing	1	66	Wire	1
31	Gear*	1	67	Wire	1
32	Gear Support	1	68	Left Rear Handle	1
33	Thrust Needle Bearing	1	69	Power Switch/Reversing Switch*	1
34	Speed Switch Lever*	1	70	Left Carbon Brush Holder*	1
35	Spring	1	71	Screw	2
36	Screw	2	72	Electric Cord Plate	1
37	Stator Bushing	1	73	Electric Cord Holder	1
38	Gasket	1	74	Power Cord Plug	1

For replacement parts and/or technical questions please call **1-800-222-5381**.



WARNING

Some dust created by power sanding, sawing, grinding, drilling, and other construction activities contains chemicals known to the State of California to cause cancer, birth defects or other reproductive harm.

Some examples of these chemicals are:

- lead from lead-based paints,
- crystalline silica from bricks and cement and other masonry products, and
- arsenic and chromium from chemically-treated lumber.

Your risk from these exposures varies, depending on how often you do this type of work. To reduce your exposure to these chemicals: work in a well ventilated area, and work with approved safety equipment, such as those dust masks that are specially designed to filter out microscopic particles.

WARRANTY

THIS WARRANTY FORM SHOULD BE RETAINED BY THE CUSTOMER AT ALL TIMES

PURCHASED FROM: _____

DATE PURCHASED: _____

The warranty is only made available by returning the tool to the place of purchase with a confirmed register receipt.

6-MONTH REPLACEMENT WARRANTY

Your IRONTON tool is covered by a 6-month replacement warranty from the date of purchase. Industrial or high-frequency use will void this warranty. The warranty covers faulty parts or workmanship.

WARNING

The following actions will result in the warranty being void.

- If the tool has been operated on a supply voltage other than that specified on the unit.
- If the tool shows signs of damage or defects caused by or resulting from abuse accidents or alterations.
- If the tool has been disassembled or tampered with in any way.

Warranty excludes consumable parts such as brushes, batteries, sanding pads, blades, discs and drill bits.



Distributed by
 Northern Tool + Equipment Co., Inc.
 Burnsville, Minnesota 55306
 NorthernTool.com
 Made in China