

NPower

4/12/25 Amp Battery Charger/Maintainer OWNER'S MANUAL

Model number-457809



Important

For safe and optimum performance, charger must be used properly. Carefully read and follow all instructions and guidelines in this manual and give special attention to the **CAUTION** and **WARNING** statements.

Please keep this manual for future reference.

TABLE OF CONTENTS

INTRODUCTION.....	2
IMPORTANT SAFETY INSTRUCTIONS.....	3
PERSONAL SAFETY PRECAUTIONS	5
AC ELECTRICAL CONNECTIONS.....	6
PLUGGING IT IN.....	6
USING AN EXTENSION CORD.....	6
PREPARING TO CHARGE.....	7
CHARGER LOCATION.....	7
BATTERY PREPARATION.....	8
CHARGING A BATTERY INSTALLED IN VEHICLE.....	9
CHARGING A BATTERY REMOVED FROM VEHICLE.....	10
CHARGER CONTROLS.....	11
CHARGING FEATURES	13
USING ENGINE START	19
BATTERY CHARGING TIMES.....	21
MAINTENANCE AND CARE	22
TROUBLE SHOOTING.....	23
SPECIFICATION.....	24
WARRANTY	25

INTRODUCTION

Thank you for purchasing ***NPower*** 4/12/25 Amp smart Battery Charger. This innovative charger will keep your AGM 12V batteries charged while maintaining top performance.

This unit was specially designed to charge and maintain your batteries without having to disconnect them from your boat or vehicle.

With built in safety features such as a reverse polarity alert, easy to read LED indicators, automatic short circuit protection, over temperature protection, and our 3-stage high-efficiency charging process, you can be assured that your battery will be charged safely and efficiently.

This manual will explain how to use the charger safely and effectively. Please read and follow these instructions and precautions carefully.

Three-stage battery charging:

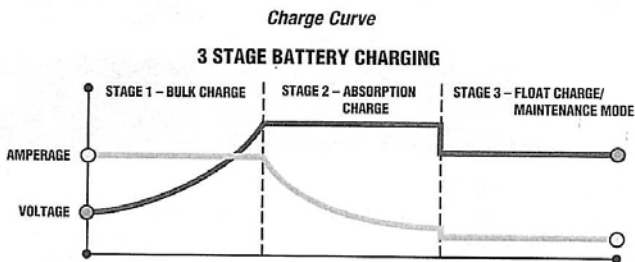

Stage One - Bulk Charge:

The Bulk Charge delivers maximum charging amperage to "wake up" any serviceable 12 volt battery and allows for quick engine start. The battery will then reach a maximum safe predetermined voltage.

Stage Two - Absorption Charge:

The Absorption Charge maintains the maximum possible charge at a constant, safe and predetermined voltage. During this phase, the charging voltage remains constant, while the actual charging current is reduced to allow for the maximum proper internal chemical energy transfer.

Stage Three - Float Charge:

The Automatic Float Charge feature is ideal for maintaining a battery. It automatically "tops off" battery as needed, to keep battery fully charged.

IMPORTANT SAFETY INSTRUCTIONS



WARNING – RISK OF EXPLOSIVE GASES

WORKING IN THE VICINITY OF A LEAD-ACID BATTERY IS DANGEROUS. BATTERIES GENERATE EXPLOSIVE GASES DURING NORMAL BATTERY OPERATION. FOR THIS REASON IT IS OF THE UTMOST IMPORTANCE THAT EACH TIME BEFORE USING YOUR CHARGER, YOU READ AND FOLLOW THE INSTRUCTIONS PROVIDED EXACTLY AS STATED.

TO REDUCE RISK OF BATTERY EXPLOSION, FOLLOW THESE INSTRUCTIONS AND THOSE PUBLISHED BY THE BATTERY MANUFACTURER.

-  **WARNING:** Handling the cord on this product or objects associated with the use of this product may expose you to lead. ***Wash hands after handling.***
- Read all instructions and cautions printed on the battery charger, battery and vehicle or equipment using battery.
- Use the charger for charging lead-acid batteries only such as those used in cars, trucks, motorcycles, boats, etc. It is not intended to supply power to a low-voltage electrical system or to charge dry-cell batteries commonly used in household appliances such as radios, toys, camera, etc. Charging dry-cell batteries may cause them to burst and cause injury to persons and damage to property.
- Use of an attachment not recommended by the battery charger manufacturer may result in the risk of fire or electrical shock.
- Do not disassemble charger. Take it to a qualified service professional if service or repair is required. Incorrect assembly may result in fire or electrical shock.
- To reduce risk of electrical shock, unplug the charger from the outlet before attempting any maintenance or cleaning.
- Do not expose charger to rain or snow.
- Never charge a frozen battery. If battery acid becomes frozen, bring battery to a warm area and allow it to thaw before you begin charging.
- Never touch the battery clamps together when the charger is on. This may cause a spark.

- Never operate a charger if it has received a hard blow, been dropped or otherwise damaged. Take it to a qualified professional for inspection.
- Never pull out the plug by the cord when unplugging the charger as this may cause damage to the cord or plug.

PERSONAL SAFETY PRECAUTIONS

- Make sure that someone is within range of your voice to come to your aid if needed while you work with or are near a lead-acid battery.
- Wear complete eye and clothing protection when working with lead-acid batteries.
- Avoid touching your eyes while working with a battery.
- Have plenty of fresh water and soap nearby for use in case battery acid contacts your eyes, skin or clothing. If this happens, wash immediately with soap and water then get medical attention.
- Never smoke or allow an open spark or flame in the vicinity of the battery or engine. Batteries generate explosive gases.
- Take care not to drop any metal tool or object onto the battery. This may result in a spark or short circuit across the battery or another electrical device that may cause an explosion.
- Remove all personal metal items, such as rings, bracelets, necklaces and watches from your body while working with a lead-acid battery. A battery can produce a short circuit



current high enough to weld such objects to metal, causing a severe burn.

- Never attempt to charge a frozen battery.
- Never overcharge a battery.
- Always operate the battery charger in an open, well-ventilated area.

AC ELECTRICAL CONNECTIONS

PLUGGING IT IN

According to local codes and ordinances, your charger requires the use of 120 Volt AC electrical wall outlet receptacles.

-  **WARNING:** Never alter AC cord or plug provided. If it does not fit the outlet, have a proper outlet installed by a qualified electrician. Improper connection can result in a risk of fire or electric shock.
-  **WARNING:** Do not operate the charger if it has a damaged power cord or plug. Have the cord replaced.

USING AN EXTENSION CORD

The use of an extension cord is not recommended. If an extension cord must be used, follow these guidelines:

- Make sure that the pins on the charger's power cord fit firmly into the extension cord and that the extension cord fits firmly into the receptacle.

- Check that the extension cord is properly wired and in good electrical condition.
- Make sure that the wire size is large enough for its length and for the AC ampere rating of the charger, as specified in the chart below.

MINIMUM RECOMMENDED EXTENSION CORD				
Length of Cord, Metres (Feet)	7.6 (25)	15.2 (50)	30.5 (100)	45.6 (150)
AWG* Size of Cord	18	16	12	10
*AWG=American Wire Gauge				

-  **WARNING:** Use of an improper extension cord could result in a risk of fire and electric shock.

PREPARING TO CHARGE

CHARGER LOCATION

- Do not expose charger to extreme weather and temperatures. Keep away from moist and wet areas.
- Place the charger as far from the battery being charged as the cables will permit.
- Be sure to position the power cord to prevent it from being stepped on, tripped over or damaged.
- Never place charger directly above battery being charged. Gases from the battery will corrode and damage the charger.
- Never set a battery on top of a charger.
- Never allow battery acid to drip on charger.

- Always charge a battery in a well-ventilated area.



WARNING: Battery chargers may get hot during operation. Do not set charger on flammable materials such as carpeting, upholstery, paper, cardboard, etc. Charger may damage leather, plastic and rubber.

BATTERY PREPARATION

- If it is necessary to remove battery from vehicle to charge it, always remove grounded terminal from battery first. Make sure all accessories in the vehicle are OFF in order to prevent sparks.
- Be sure that the area around the battery is well ventilated while being charged.
- Clean the battery terminals. Be careful to keep corrosion or battery acid from getting in or around your eyes.
- For batteries with removable vent caps, if required, add distilled water to each cell until the battery fluid reaches the level specified by the battery manufacturer. **Do not overfill.** For batteries without removable vent caps, carefully follow the manufacturer's charging instructions.
- Study all of the battery manufacturer's specific precautions and recommendations for charging and for recommended rates of charge.
- Make sure that you have a 12 V lead-acid battery. Determine voltage of battery by referring to the vehicle owner's manual. If the charger has an adjustable charge rate, charge battery at the lowest rate first.

CHARGING A BATTERY INSTALLED IN VEHICLE

NOTE: A marine battery installed in a boat must be removed and charged on shore. To charge it on board requires equipment specially designed for marine use.

- Connect and disconnect the DC output clamps only after removing the AC plug from the electrical outlet.
- Never allow the DC output clamps to touch each other. This may cause a spark.

FOLLOW THESE STEPS WHEN BATTERY IS INSTALLED IN VEHICLE. A SPARK NEAR BATTERY MAY CAUSE A BATTERY EXPLOSION. TO REDUCE THE RISK OF A SPARK NEAR BATTERY:

1. Position AC and DC cords to reduce the risk of damage by hood, door, or moving engine part.
2. Stay clear of fan blades, belts, pulleys, and other parts than can cause injury to persons.
3. Check polarity of battery posts. A positive (POS, P, +) battery post usually has a larger diameter than a negative (NEG, N, -) post.
4. Determine which battery post is grounded (connected) to the chassis. IT IS NORMALLY THE NEGATIVE POST.
5. **Connecting to a negative-grounded system:**
Connect the positive (red) clip from a battery charger to a positive (POS, P, +) ungrounded post of battery.
Connect the negative (black) clip to vehicle chassis or engine block away from battery. Do not connect clip to

carburetor, fuel lines, or sheet-metal body parts. Connect to a heavy gauge metal part of the frame or engine block.

Connecting to a positive-grounded system: Connect the negative (black) clip from battery charger to negative (NEG, N, -) ungrounded post of battery. Connect the positive (red) clip to vehicle chassis or engine block away from battery. Do not connect clip to carburetor, fuel lines, or sheet-metal body parts. Connect to a heavy gauge metal part of the frame or engine block.

6. Connect charger AC supply cord to electric outlet.
7. Charge battery as outlined in **OPERATION INSTRUCTIONS** section.
8. When disconnecting charger, disconnect AC cord, remove clip from vehicle chassis, and then remove clip from battery terminal.

CHARGING A BATTERY REMOVED FROM VEHICLE

- Connect and disconnect the DC output clamps only after removing the AC plug from the electrical outlet.
- Never allow the DC output clamps to touch each other. This may cause a spark.

FOLLOW THESE STEPS WHEN BATTERY IS REMOVED FROM VEHICLE. A SPARK NEAR BATTERY MAY CAUSE A BATTERY EXPLOSION. TO REDUCE THE RISK OF A SPARK NEAR BATTERY:

1. Check polarity of battery posts. A positive (POS, P, +) battery post usually has a larger diameter than a negative (NEG, N, -) post.
2. Attach at least a 60cm 6-gauge (AWG) insulated battery cable to a negative (NEG, N, -) battery post.
3. Connect the positive (red) charger clip to the positive (POS, P, +) post of battery.
4. Position yourself and the free end of cable as far away from battery as possible, and then connect the negative (black) charger clip to the free end of cable.
5. Do not face battery when making final connection.
6. Connect charger AC supply cord to electric outlet.
7. Charge battery as outlined in **OPERATING INSTRUCTIONS** section.
8. When disconnecting chargers, always do so in reverse sequence of connecting procedure and break first connection while standing as far away from battery as practical.

CHARGER CONTROLS

DIGITAL DISPLAY MODE SELECTION

Press the Display Mode button to toggle digital display content as follows:

- **Current** – When selected, charging current (A) will be displayed.

- **Voltage** – When selected, charging voltage (V) will be displayed. The voltage displayed is the charging voltage and usually will be higher than the battery’s resting voltage.
- **Battery Capacity %** - When selected, approximate percentage of battery charge will be displayed.
 - At less than 50% battery capacity, the display will read “LO”
 - The display will increase in 10% increments between 50% to 90% capacity. Such as “80”.
 - At full charge, the display will read will read “FUL”

CHARGE RATE SELECTION

Press the Charge Rate button to select desired charge rate as follows:

- **4-25 A Automatic Charge** – To help extend the life of your battery and ensure it is delivering its maximum potential, it is important to charge the battery at a rate that is appropriate and safe for its capacity. Charging a battery at too high a charge rate, while fast, may shorten the expected life of a battery. Charging a battery at too low a charge rate, while safer, takes longer and does not ensure the battery will reach 100% of its capacity. Optimal Charge logic automatically selects the ideal charge rate for your battery. In Optimal Charge mode, the charger starts charging at a low, safe current. Gradually, the charger increases current as the battery demonstrates it can accept a higher current. The result is a battery safely charged to its utmost capacity.

- **12 A or 25 A Charge Rate** – Use for faster charging of small-to-large capacity automotive, marine, deep cycle and farm tractor batteries.
- **4 A Charge Rate** - Use for slow charging small-to-large capacity automotive, marine, deep cycle and farm tractor batteries. Also for garden tractor batteries.
- **2 A maintainer mode**- use for maintain the battery with large capacity. Connect from the 2A maintainer port by accessory cables included.

CHARGER FEATURES

CONNECTION METHODS

This charger comes with 2 run connect charging leads for extra versatility – standard clamps and ring terminals. The battery may be charged using any of the two connection options.



Warning: you can only select one charging method for charging.

CHARGE STATUS INDICATOR

A blinking green LED indicates that the battery is being charged. A solid green LED indicates that the battery is fully charged or that the charger is in Maintenance mode.

AUTOMATIC SHUT OFF

The battery charger is designed to automatically shut off once battery charging is complete to prevent overcharging. When

charging is complete, the Charge Status LED will stop blinking and the digital display will read “FUL”.

COMPLETION OF CHARGING

Charge completion is indicated when the Charge Status LED stops blinking and illuminates continuously (green). The digital display will also show a “FUL” message. The charger has stopped charging and switched to Maintenance mode.

MAINTENANCE MODE

Once charging is complete, the charger will automatically go into Maintenance mode (also known as float mode monitoring). In this mode, the charger keeps the battery fully charged by delivering a small amount of current, when necessary, to keep the battery at peak charge. This process will keep for around 1 hour, and after that, the digital display will show you “FUL”, and the DC clamps will automatically out of power.

REVERSE POLARITY PROTECTION

If the cables are incorrectly connected to the battery, the Reverse Polarity indicator will illuminate. Note: the charger will not begin charging if the Reverse Polarity indicator is lit.

BATTERY RECONDITIONING MODE

If a battery is left discharged for an extended period of time, it could become sulphated, unable to accept a charge. Reconditioning Mode may help reverse the effects of sulphating and restore a batteries ability to accept a charge. If the charger detects a sulphated battery, it will automatically activate Battery Reconditioning mode, indicated by a blinking yellow LED. And

the digital display will show you”-“in turns. If successful, normal recharging will resume after the battery is desulphated. If the first attempt at desulphation is unsuccessful, the battery charger will make up to four more attempts. If still unsuccessful at desulphating the battery, fault code “F01” will be displayed indicating the battery will not accept a charge and should be replaced.

ABORTED CHARGES

If charging can't be completed normally, charging will be aborted. The digital display may show a fault code. To reset the charger after an aborted charge, disconnect the battery or unplug the charger.

BATTERY DIAGNOSTICS

The charger continuously monitors battery condition and may report certain charging failures as fault codes. Refer to the section called “**FAULT CODES**” for a complete list.

COOLING FAN OPERATION

The charger is designed to control its high speed cooling fan for efficient operation. Consequently, it is normal for the fan to start and stop during charging.

OVERHEAT PROTECTION

The charger is designed to shut itself off if overheating is detected. Once the charger cools down, it will resume charging automatically.

Features:

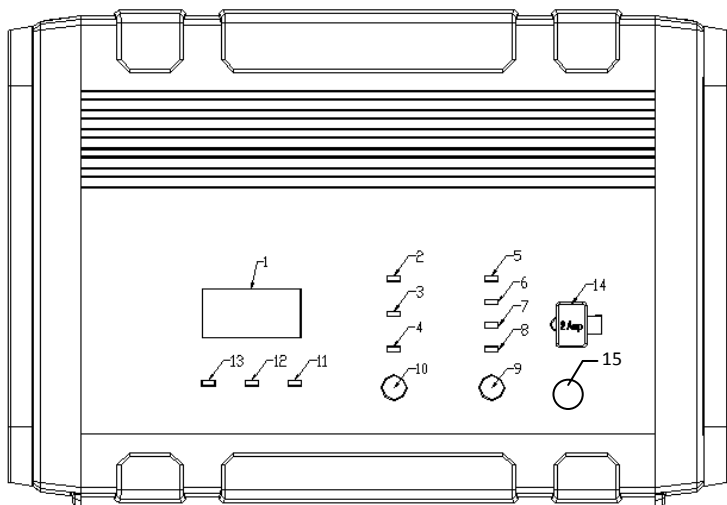

Front panel view

1. Display Panel—It can indicate present voltage, present current, present battery capacity or wrong condition code.

With AC power input, when not connected to the battery, the charger shows that there is no power output with the display panel present moving “8”. After connected to the battery, the panel will display the battery information according to what you choose. If the battery voltage is higher than $13.6\pm 0.2V$, the panel will displays “FUL”.

When error occurs, the panel displays error code.

The meanings of the codes and the solutions are enumerated in the troubleshooting table.

2. Current Indicator--It is a green LED indicator. When the display panel indicates the present current, this LED indicator illuminates.

3. Voltage Indicator--It is a green LED indicator. When the display panel indicates the present voltage, the voltage LED indicator illuminates.

4. Battery level indicator--When the display panel indicates the battery level, this LED indicator will illuminate.

Code	Condition
LO	low Battery
60~90	Current battery level
FUL	Full Battery

5. Automatic charging indicator-it indicates the charging rate you choose is automatic.

6. 4A current indicator – It indicates the charging rate you choose is 4A.

7. 12A current indicator-- It indicates the charging rate you choose is 12A.

- 8. 25A current indicator**-- It indicates the charging rate you choose is 25A.
- 9. Charging rates selecting switch**--You can choose the charge rates-4A, 12A or 25A by pressing this switch.
- 10. Display Button Switch**--You can choose what to display on the panel by pressing the button. The default display is the current charging rate.
- 11. Reverse Polarity LED** --It is a red LED. when clips connected the battery in the wrong way, this red LED illuminates.
- 12. Battery Recondition Indicator**--It is a yellow LED, when the battery is reconditioned, this LED flash.

The charger will estimate automatically whether the battery recondition is needed. It will recondition the battery only when the battery has gone into float charge and the voltage is lower than 13V. The process cycles every 4 ± 0.5 h until the voltage is higher than 13V. If it cycles 5 times and the voltage is still lower than 13V, there will be a code "F01" present on the display panel, indicating error. Please replace the battery.

- 13. Charging State LED** --It is a green LED, when battery is charged at a constant current or a constant voltage, the green LED flash. When the battery goes into float charge, the charger will cut receiving power to battery for 1 minute to check the charging state. At this time, the green LED illuminates. If it checks the battery is full charged or goes into float charge, this green LED will illuminate steadily.

14. 2Amp Maintainer – Use 2Amp port to do the battery maintenance.

15. Engine start button- use to jumpstart your vehicle's battery if it is low.

Operation for the 2Amp Maintainer.

To connect the maintainer cord to the charger, and connect the Clamps cable or Ring cable to the battery, positive (+) to positive (+), negative (-) to negative (-). Then connect the clamp cable or ring cable to the maintainer port, the red wiring LED will light up if you connect the cables to the battery in a wrong way, and the green LED will light up if you connect the cables in the correct way.

Note: The digital display only show you “8” in turns when use 2Amp Maintainer cord. Do not use the battery maintainer and the battery charger simultaneously.

USING ENGINE START

Your battery charger can be used to jump start your vehicle if the battery is low.

IMPORTANT: The Engine Start feature cannot be used if a battery is not installed in the vehicle. The charger must detect some voltage from the battery or it will not go into Engine Start mode.

1. Make battery and AC connections as outlined in “**CHARGING A BATTERY INSTALLED IN A VEHICLE.**”
2. Press the **Engine Start** button.
 - Once the Engine Start button is pressed, the charger will begin to charge the battery at up to 25 A until an attempt is made to crank the engine.
3. Crank the engine for no more than 5 seconds. If the engine does not start, wait at least 3 minutes before attempting crank again.
 - Only when actual engine cranking is detected will the charger then automatically deliver 75 A for up to 5 seconds or until the cranking stops. The digital display will countdown the crank time in seconds, starting at 555, 444, 333... down to 000.
 - After 5 seconds of cranking, the charger automatically enters cool down mode for 3 minutes to protect the charger, battery and starter from damage. The digital display will begin counting down in seconds from 180 down to 0. During this time, the charger will continue to charge the battery at a rate of up to 25 A.
4. After the engine starts, unplug the AC cord and disconnect the cables from the battery.

NOTE: A severely discharged battery may not be able to start an engine even with the assistance of the 75A Engine Start. If your first few attempts to boost the vehicle are unsuccessful, try charging the battery at 25 A for 20 minutes before attempting to boost again.

BATTERY CHARGING TIMES

The built-in intelligent microprocessor will continuously monitor and adjust the charger to provide a fast, safe and efficient charge. Note that battery charge times will vary depending on several factors including:

1. **Battery State** – If a battery has been only slightly discharged, it can be charged in less than a few hours. This same battery could take up to 10 hours if very discharged.
2. **Battery Rating** – A higher rated battery will take longer to charge than a lower rated battery under the same conditions. A battery is rated in ampere-hours (Ah), reserve capacity (RC) and cold-cranking amps (CCA).
3. **Charge Rate** – The charge rate is measured in amps. A battery charged at a lower rate will take longer than a battery charged at a higher rate. However, smaller batteries can be easily damaged by charging at a rate which is too high for the capacity of the battery.
4. **Temperature** – Cold temperature will affect a batteries ability to accept a charge. Charging in cold temperatures will increase the amount of time required to charge a battery.

Please consult the table to help you to choose the charging rate

The current you choose to charge the battery	The capacity of the battery recommended
4A	16AH~40AH
12A	48AH~120AH
25A	$\geq 100AH$

NOTE:

If battery size is not known, charge at the 2amp rate. DO NOT overcharge batteries.

MAINTENANCE AND CARE

- Clean cords and clamps each time you are finished using the charger. Wipe off any battery fluid or debris that might have come in contact with the clamps to prevent corrosion.
- Store the power and output cable neatly to prevent damage.
- Occasional cleaning of the battery charger case with a soft cloth will help protect the finish.
- Always unplug the charger when not in use.
- Keep the charger stored in a cool, dry place.

TROUBLESHOOTING FAULT CODES

FAULT CODES

Code	Condition	Possible Cause	Solution
F01	The battery voltage is less than 10 V after 10 minutes of charging.	Maybe there is short circuit in the battery.	Go to a professional Lab to test the battery.
		A load may be connected to the battery.	Disconnect the load and attempt to charge again.
	The battery voltage is still less than 13 V after multiple reconditioning attempts.	The battery is sulphated beyond reconditioning.	Replace the battery.
F02	Charge voltage is too high.	Battery is 24 V, not 12 V.	Confirm that battery is 12 V.
F03	Charge current is too high.	A load may be connected to the battery.	Disconnect the load and attempt to charge again.
F04	The temperature of the charger is too high.	High ambient temperature.	Ensure adequate ventilation. The charger will resume charging after cooling.
F05	The battery does not go into	The charge current is too	Select a higher charge rate.

Maintenance mode after being charged for 24 hours.	low, can't fully charge the battery	
	Maybe there is short circuit in the battery.	Go to the specialist to check the battery.
	The battery is used during charging	Disconnect the load.
	The self-discharging current is larger than the floating current	Please select higher charging rate charger.

SPECIFICATION

Rated input voltage	120V AC/60Hz
Input current	3A
Maximum output current	25±2.5A
Battery type	12V lead-acid battery
ambient temperature	32°F ~104°F (0°C ~40°C)
Weight	2.43Kg
Dimension (L×W ×H)	34*10.5*22cm

WARRANTY

The limited warranty program is the only one that applies to this unit, and it sets forth all the responsibilities of *NPower*. There is no other warranty, other than those described herein. Any implied warranty of merchant ability of fitness for a particular purpose on this unit is limited in duration to the duration of this warranty.

This unit is warranted, to the original purchaser only, to be free of defects in materials and workmanship for one year from the date of purchase without additional charge. The warranty does not extend to subsequent purchasers or users.

Manufacturer will not be responsible for any amount of damage in excess of the retail purchase price of the unit under any circumstances. Incidental and consequential damages are specifically excluded from coverage under this warranty.

This unit is not intended for commercial use. This warranty does not apply to damage to units from misuse or incorrect installation/connection. Misuse includes wiring or connecting to improper polarity power sources.

RETURN/REPAIR POLICY:

If you are experiencing any problems with your unit, please contact our customer service department at **800-222-5381** before returning product to retail store. After speaking to a customer service representative, if products are deemed non-working or malfunctioning, the product may be returned to the purchasing store with 30 days of original purchase. Any defective unit that is returned to manufacturer within 30 days of the date of purchase will be replaced free of charge.

If such a unit is returned more than 30 days but less than one year from the purchase date, manufacturer will repair the unit or, at its option, replace it, free of charge. If the unit is repaired, new or reconditioned replacement parts may be used, at manufacturer's option. A unit may be replaced with a new or reconditioned unit of the same or comparable design. The repaired or replaced unit will then be warranted under the terms of the remainder of the warranty period. The customer is responsible for the shipping charges on all returned items.

LIMITATIONS:

This warranty does not cover accessories, such as adapters and batteries, damage or defects result from normal wear and

tear (including chips, scratches, abrasions, discoloration or fading due to usage or exposure to sunlight), accidents, damage during shipping to our service facility, alterations, unauthorized use or repair, neglect, misuse, abuse, failure to follow instructions for care and maintenance, fire and flood.

If your problem is not covered by his warranty, call our Customer Service Department toll free at 800-222-5381 for general information if applicable.