

SPLASH LUBRICATED AIR COMPRESSOR PUMPS

*Airbase Industries designs and manufactures products for safe operation. However, operators and maintenance persons are responsible for maintaining safety. All safety precautions are included to provide a guideline for minimizing the possibility of accidents and property damage while equipment is in operation. **Keep these instructions for reference.***

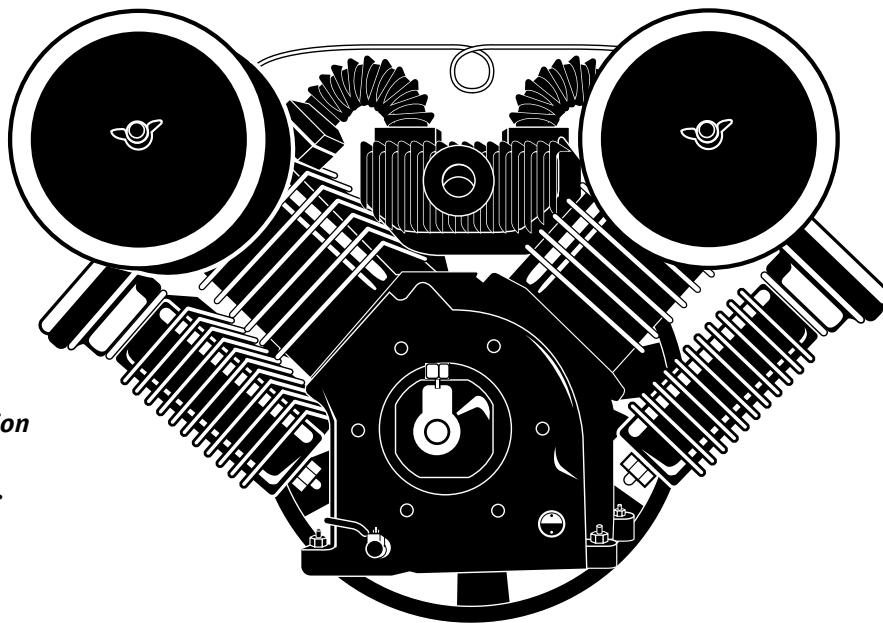

Unit configuration and appearance varies by model.

Contents

	Page No.		Page No.
Model Specification Charts	2	Operation	6
Safety Information	3	Safety Rules	6
Tag Definitions	3	Start Up	6
Basic Guidelines	3	Maintenance	7
Breathable Air	3	Safety Steps	7
Personal Protective Equipment	3	Belt Adjustment	7
Inspection	3	Changing Oil	7
Installation	3	Maintenance Schedule	7
Area	3	Troubleshooting	8
Piping Safety Steps	4	Warranty	8
Tank Installation	4		
Pump Installation	5		

SINGLE STAGE
Splash Lubricated, Air Compressor Pumps

Model	APP2V0313S	APP3Y0518S	APP2V0732S
Description	3HP	5HP	7.5HP
CFM Displacement	13	18	32
CFM @ Pressure (100 psi)	10.2	14.1	18
Max PSI	145	145	145
Noise DB(A)	75	75	74
Outlet Connection	NPT 1/2"	NPT 1/2"	NPT 3/4"
Pump RPM	850	950	680
Bolt Pattern	8-3/16 x 4-5/8	8-1/4 x 5-1/4	10-1/4 x 5-3/8
Dimensions <small>L*W*H (inches)</small>	15 x 10 x 13	18 x 15 x 12	18 x 15 x 12
Weight (lbs.)	60	75	121
Belt Type (A or B)	A	A	B
Number of Belts	1	2	2

TWO STAGE
Splash Lubricated, Air Compressor Pumps

Model	APP3Y0521T	APP2I0524T	APP3Y0732T	APP4V1043T	APP3Y1544T	APP3Y2062T	APP4V2598T
Description	5HP - 3cyl	5HP- 2cyl	7.5HP	10HP	15HP	20HP	25HP
CFM Displacement	21	24	32	43	44	62	98
CFM @ Pressure (100 psi)	18	17	24	34	35	52	91
Max PSI	175	175	175	175	175	175	175
Noise DB(A)	74	75	75	75	75	75	79
Outlet Connection	NPT 3/4"	NPT 3/4"	NPT 3/4"	NPT 3/4"	NPT 1-1/4"	NPT 1-1/4"	NPT 1-1/4"
Pump RPM	895	795	830	600	640	640	710
Bolt Pattern	9-7/8 x 6-1/2	7-3/4 x 9	9-7/8 x 6-1/2	9-1/4 x 9-1/4	13-1/2 x 6-3/4	13-1/2 x 6-3/4	13-5/8 x 12 5/8
Dimensions <small>L*W*H (inches)</small>	25 x 13 x 18	16 x 14 x 19	25 x 13 x 18	28 x 21 x 21	27 x 14 x 27	27 x 14 x 27	38 x 29 x 26
Weight (lbs.)	133	180	149	282	321	369	684
Belt Type (A or B)	B	B	B	B	B	B	B
No. of Belts	2	2	2	2	3	3	4

Safety

This manual contains very important information to know and understand. This is provided for SAFETY and to PREVENT EQUIPMENT PROBLEMS. To help understand this information, observe the following:

▲ DANGER Danger indicates an imminently hazardous situation which, if not avoided, *will* result in death or serious injury.

▲ WARNING Warning indicates a potentially hazardous situation which, if not avoided, *could* result in death or serious injury.

▲ CAUTION Caution indicates a potentially hazardous situation which, if not avoided, *may* result in minor or moderate injury.

NOTICE Notice indicates important information, that if not followed, may cause damage to equipment.



Read all manuals included with this product carefully. Be thoroughly familiar with the controls and the proper use of the equipment.

Basic Guidelines

1. Allow only trained, authorized persons who have read and understood these operating instructions to use this compressor pump. Failure to follow the instructions, procedures and safety precautions in this manual can result in accidents and injuries.
2. NEVER start or operate the compressor pump under unsafe conditions. Tag the compressor, disconnect and lock out all power to it to prevent accidental start-up until the condition is corrected.
3. Install, use and operate the compressor pump only in full compliance with all pertinent OSHA regulations and all applicable Federal, State & Local Codes, standards and regulations.
4. NEVER modify the compressor pump and/or controls in any way.
5. Keep a first aid kit in a convenient place. Seek medical assistance promptly in case of injury. Avoid infection by caring for any small cuts and burns promptly.

Breathable Air

1. NEVER use air from this compressor pump for breathable air except in full compliance with OSHA Standards 29 CFR 1910 and any other Federal, State or Local codes or regulations.

▲ DANGER



Death or serious injury can result from inhaling compressed air without using proper safety equipment. See OSHA standards on safety equipment.

2. DO NOT use air line anti-icer systems in air lines supplying respirators or other equipment used to produce breathable air. DO NOT discharge air from these systems in unventilated or other confined areas.

Personal Protective Equipment

Be sure all operators and others around the compressor and its controls comply with all applicable OSHA, Federal, State and Local regulations, codes and standards relating to personal protective equipment. This includes respiratory protective equipment, protection for the extremities, protective clothing, protective shields and barriers, electrical protective equipment, and personal hearing protective equipment.

Inspection

▲ WARNING

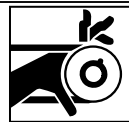

Inspect compressor pump prior to any use. Check for external damage that might have occurred during transit. *Be careful of moving parts* then test pulley by turning it freely by hand. **Report any damage to delivery carrier immediately.**

▲ WARNING

Do not operate unit if damaged during shipping, handling or use. Damage may result in bursting and cause injury or property damage.

Installation

Area

1. Install compressor pump in a clean, dry and well-lit area. Be sure installation area can maintain a temperature range between 35° - 110° F.
2. Insulate cold water or other low temperature pipes that pass overhead to avoid condensation dripping on compressor which could cause rust and/or motor shorting.

▲ DANGER



DO NOT install compressor in boiler room, paint spray room, or area where sandblasting occurs. Make sure inlet air is away from exhaust fumes or other toxic, noxious or corrosive fumes or substances.

3. If acid is used in operating environment or air is dust laden, pipe intake to outside, fresh air. Increase pipe size by one size for every 20 feet of run. Be sure to install protective hood around intake filter.
4. In operating environments where excessive water, oil, dirt, acid or alkaline fumes are present, a TEFC (totally enclosed, fan cooled) motor is recommended. Check nameplate for motor type.
5. Allow sufficient space around compressor pump for maintenance access. Mount unit with pulley towards wall and leave a minimum of 15 inches of clearance.
6. Use shims to level compressor if installation area is not flat. This will avoid excessive vibration and premature pump wear.

Piping

Safety Steps

1. Install appropriate flow-limiting valves as necessary according to pipe size(s) used and run lengths. This will reduce pressure in case of hose failure, per OSHA Standard 29 CFR 1926.302(b)(7).
2. Flow-limiting valves are listed by pipe size and rated CFM. Select appropriate valves accordingly, in accordance with the manufacturer’s recommendations.

Tank Installation

1. Place tank feet on 1/4” thick rubber pads. Thicker padding will increase vibration and the possibility of cracking the tank or other unit damage. **Do not place unit on dirt floor or uneven surface.**
2. Fasten anchor bolts snugly but do not overtighten so normal vibration will not damage unit.

⚠ DANGER *Compressor unit is top heavy and must be bolted to solid, flat surface to avoid falling and premature pump wear. Splash lubrication will not operate properly if unit is not level.*

Pump Installation

1. Mount pump to deck of tank then connect main feed port to check valve in tank. See figure 1.
2. For units with centrifugal unloader system, install 1/4” copper tubing from 90° elbow (located in front of crankcase) to the unloader port of check valve.

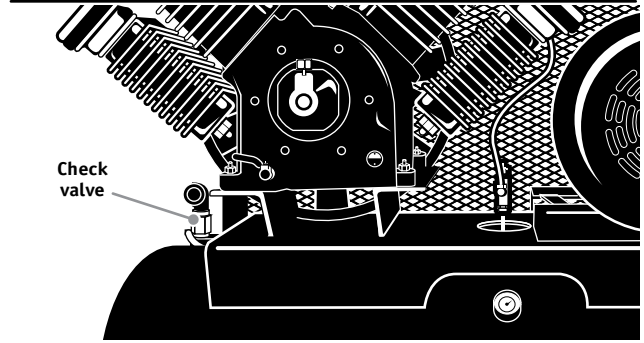

Figure 1: Connect feed port to check valve

NOTE: If pump is not equipped with centrifugal unloader, install an unloader line from the check valve unloader port to the unloader port of the pressure switch. This will relieve head pressure when unit stops and provide no-load restarting.

3. Cap fitting on cylinder heads if not using pilot valve for continuous run port.
4. Make sure there is a 1/4” copper tube (unloader tube) installed from tank check valve to unloader on pressure switch. This relieves head pressure when compressor stops for easier restart. See figure 2.

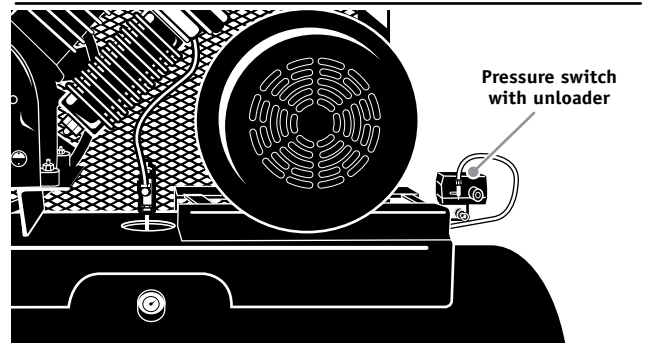

Figure 2: Install unloader line from check valve to pressure switch

5. Use proper pulley for motor. Refer to Pulley Size Chart for correct sizing.
6. Install belts. There should be 1/2” slack for proper belt tension. See figure 3.
7. Use a flexible connector between compressor tank and piping system to minimize noise, vibration, unit damage, and pump wear.

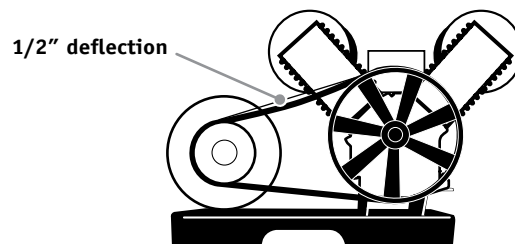

Figure 3: Proper belt tension

Pulley Size Chart
(Pulley size in inches)

Pump Model No.	Electric Motor - Hp	1750 RPM 4 Pole Motor	3450 RPM 2 Pole Motor	Gas Engine Hp	Gas Engine Pulley Size
APP2V0313S	3	5.5	2.75	5.5	3
APP3Y0518S	3	5.5	2.75	6.5	3
APP3Y0518S	5	5.75	2.75	6.5	3
APP3Y0521T	5	7	3.5	8	3.5
APP2V0732S	5	5.5	2.75	8	3
APP2I0524T	5	7.7	3.8	11	4
APP3Y0732T	5	6	3	11	3
APP3Y0732T	7.5	7	3.5	13	4
APP4V1043T	7.5	6.4	3.2	13	3.2
APP4V1043T	10	8.8	4.4	18	4.4
APP3Y1544T	10	9	4.5	24	4.5
APP3Y2062T	15	9	4.5	28	4.5
APP4V2598T	20	9	4.5	40	4.5
APP4V2598T	25	11.5	5.8	50	5.8

NOTICE

Splash lubricated pumps require 550 RPM for proper lubrication. Be sure to size motor and engine pulleys correctly.

- Install appropriate ASME code safety valves and make sure piping system is equipped with adequate condensate drains. See figure 4.

WARNING



Never install a shut-off valve such as a glove or gate valve, between the pump discharge and the air tank unless a safety valve is installed in the line between valve and pump.

- Make sure any tube, pipe or hose connected to the unit can withstand operating temperatures and retain pressure.

WARNING

Never use plastic (PVC) pipe for compressed air. Serious injury or death could result.

- Never use reducers in discharge piping. Keep all piping and fittings the same size in the piping system.
- For permanent installations of compressed air systems, determine total length of system and select correct pipe size. Make sure underground lines are buried below frost line and avoid areas where condensation could build up and freeze.

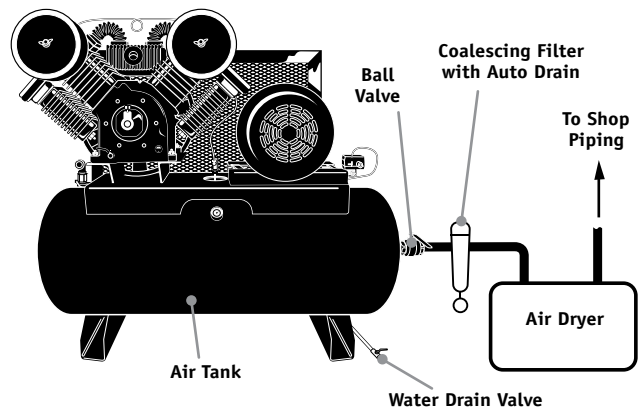

Figure 4: Basic Piping Diagram

Minimum Pipe Size For Compressed Air Lines
(Pipe size shown in inches)

SCFM	Length Of Piping System			
	25 ft.	50 ft.	100 ft.	250 ft.
20	3/4	3/4	3/4	1
40	3/4	1	1	1
60	3/4	1	1	1
100	1	1	1	1-1/4
125	1-1/4	1-1/4	1-1/2	1-1/2

12. Test entire piping system *before* underground lines are buried. Be sure to find and repair all leaks before using compressor.

▲ WARNING *Never exceed recommended pressure or speed while operating compressor.*

▲ WARNING *Be sure to install beltguard on compressor unit after pump installation is complete.*



Operation

Safety Rules

1. Make sure all operators receive product training, read and understand all instructions.

▲ WARNING *Keep all flammable, combustible, poisonous and noxious materials away from operating area. Make sure there are no oily rags, trash, leaves, litter or other combustible materials in operating area. Keep*



suitable, fully charged fire extinguishers nearby when servicing and operating the compressor.

2. **NEVER** allow modifications to compressor structure or controls.
3. Keep all ignition sources away from exposed electrical parts.
4. Keep all persons clear of compressor during start-up and operation.
5. NEVER operate the compressor with the fan, coupling or other guards removed.
6. DO NOT engage in horseplay with air hoses as death or serious injury may result.
7. Make sure to provide adequate ventilation and use proper lubricant while operating the compressor. If lubricant or other combustible substances are spilled, clean up immediately.
8. When checking or adding lubricant or when refilling air line anti-icer systems with antifreeze compound, shut off compressor and allow it to cool. Keep sparks, flames and other ignition sources away and DO NOT permit smoking in the vicinity.
9. Stop compressor and disconnect power if a hazardous condition arises.
10. Wear snug fitting clothing and confine long hair when around compressor. Keep all body parts and clothing away from couplings, flywheel and other moving parts of the equipment.

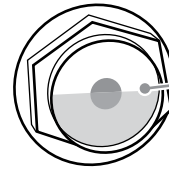

Oil level should be to center of red circle in site glass

Figure 5: Check proper oil level

▲ WARNING *Keep all persons away from the discharge opening of hoses or tools or other points of compressed air discharge. If the machine is installed in an enclosed area, be sure to vent the relief valve outside of the structure or to an unoccupied area.*



11. DO NOT use air tools that are rated below the maximum rating of the compressor. Select air tools, air hoses, pipes, valves, filters and other fittings accordingly. DO NOT exceed manufacturer's rated safe operating pressures for these items.
12. Make sure all hose connections are adequately secured to prevent tools or hose ends from being accidentally disconnected.

Start-Up

1. This unit may or may not contain oil when shipped. Be sure to check for proper oil level before operating the compressor. Oil should be in center of site glass. See figure 5.

NOTICE *Use only Airbase Industries oil (PN: AP0L03000G1). Use of any other product will cause product damage and void the warranty.*

2. Check for proper belt tension. There should be 1/2 inch slack. Refer to figure 3, pg. 4.

▲ WARNING *Always make sure main power is off before touching belts or other moving parts of compressor.*



3. Push power switch to make sure system is working.
4. Ensure motor rotation is correct. Refer to unit operating instructions if necessary.

Maintenance

Safety Steps

▲ WARNING



Disconnect, tag and lock out power source then release all pressure from the system before attempting to install, service, relocate or perform ANY maintenance.

1. Make sure repairs are done in a clean, dry, well lighted and ventilated area.
2. When cleaning, use air pressure less than 30 psig (2.1bar). NEVER use flammable solvents for cleaning purposes. Also use effective chip guarding and personal protective equipment per OSHA standard 29 CFR 1910.242 (b).
3. Relieve all internal pressure prior to opening any line, fitting, hose, valve, drain plug, connection or other component, such as filters and line oilers, and before refilling optional air line anti-icer systems with antifreeze compound.

▲ CAUTION



Compressor components can become hot during operation. Avoid bodily contact with hot liquids, hot surfaces and sharp edges and corners.

Belt Adjustment

▲ WARNING



Be sure to relieve all system pressure then lock out power and tag compressor to prevent unexpected movement of the unit.

Inspect belt tension after first 30 hours of operation then every 30 days.

1. Proper belt tension is determined by pressing on belt midway between motor pulley and flywheel. There should be approximately 1/2 inch of deflection. Refer to figure 3, pg. 4.
2. Always replace all belts with the same brand, at the same time. Make sure belts are uni-matched. Do not replace belts independently.
3. Do not splash lubricating oil on belts or pulleys when adjusting or replacing belts.

Changing Oil

Some units are shipped with break-in oil. Change oil within first 50 hours or 30 days of operation, whichever comes first. **DO NOT use automotive type oil.**

NOTICE

Use only Airbase Industries oil (PN: AP0L03000G1). Use of any other product will cause product damage and void the warranty.

Change oil every 90 days or if oil becomes milky. High humidity and excessive temperature changes can cause moisture to form in the pump. This moisture will cause oil to break down and become milky. Be sure to check oil regularly for proper lubrication. Make sure to dispose of used parts such as oil and filters in accordance with all applicable regulations.

Maintenance Schedule

Daily	<input type="checkbox"/> Check oil level <input type="checkbox"/> Check for unusual operation. Correct before damage occurs.	<input type="checkbox"/> Check safety valve <input type="checkbox"/> Drain tank and traps
Weekly	<input type="checkbox"/> Clean air filter <input type="checkbox"/> Change oil (<i>after first 50 hours</i>)	<input type="checkbox"/> General unit cleaning <input type="checkbox"/> Check for unusual operation. Correct before damage occurs.
Monthly	<input type="checkbox"/> Check and tighten all bolts as required <input type="checkbox"/> Check all connections for air leaks <input type="checkbox"/> Check belts for proper tension, wear, and alignment	<input type="checkbox"/> Inspect oil for contamination. Change if necessary. <input type="checkbox"/> Check all unloading lines for leaks. <i>Air leaks in unloader lines will cause unloaders and pilot valve to chatter and could cause short cycling of motor.</i>
Every 3 months	<input type="checkbox"/> Change oil	<input type="checkbox"/> Inspect valve assemblies

Troubleshooting Chart

Problem	Possible Causes	Resolutions
Low air pressure	<ol style="list-style-type: none"> 1. Clogged inlet filter 2. Air leak(s) in system 3. Application exceeds rated air output of compressor 4. Cylinder head valves not sealing 5. Insufficient power 	<ol style="list-style-type: none"> 1. Disassemble valve, clean thoroughly 2. Use soapy water to locate leaks, replace or tighten threaded parts 3. Check CFM requirements, change tool or use compressor with higher air output 4. Remove valves from cylinder head, repair or replace as necessary 5. Check power supply, rewire as necessary
Overheating	<ol style="list-style-type: none"> 1. Duty cycle exceeded 2. Improper rotation 3. Head valve(s) not seating properly 4. Blown cylinder head gasket(s) 5. Restriction in head, intercooler or check valve 6. Low oil 7. Dirt in intercooler fins or cylinder fins 8. Poor ventilation / ambient temperature too high 	<ol style="list-style-type: none"> 1. Keep duty cycle at 60/40 to maintain pump life 2. When facing flywheel, ensure counter-clockwise rotation 3. Clean or replace 4. Replace gasket(s) 5. Clear blockage 6. Add oil. Ensure oil level is at middle of site glass. See figure 5, pg. 6. 7. Use low pressure air to blow dirt away from compressor 8. Increase ventilation around operating area. Ensure compressor has adequate clear space from walls and other possible obstructions. Ambient temperature should not exceed 110° F.

NOTICE Use only Airbase Industries oil (PN: **APOL03000G1**). Use of any other product will cause product damage and void the warranty.

Airbase Industries makes the following WARRANTY STATEMENT:

1. THAT EACH **BARE COMPRESSOR PUMP UNIT** TO BE FREE FROM DEFECTS IN MATERIAL, WORKMANSHIP, AND PARTS FOR 2 YEARS FOR THE UNIT FROM THE DATE OF PURCHASE. Airbase Industries (and each of its subsidiaries) is not responsible for downtime during warranty service. If downtime is necessary, it is the Purchaser's discretion and obligation (at Purchaser's expense) to have a redundant COMPRESSOR PUMP. Warranty repairs shall not include freight costs. Purchaser is responsible for returning unit to Airbase Industries. This PUMP MUST have Airbase Industries Lubricant Synthetic exclusively, the same which must be purchased from Airbase Industries. (Mixing different brands of oil will void this warranty). A service kit must be purchased from Emax or an Emax dealer for this warranty to apply. Service kits contain an air filter and synthetic oil that must be changed annually. Annual proof of purchase of all oil programs must be maintained by the original purchaser of the compressor pump. If the unit runs out of oil, this warranty is void. Failure to fully comply with this warranty and fully comply with the manual herein will void this warranty.

Exclusions include: service such as OIL CHANGES, FILTER REPLACEMENTS, GASKET TIGHTENING TO CORRECT OIL SEEPAGE or DRIVE BELT TIGHTENING and VALVE CLEANING and are not covered under warranty.

Warranty shall be void under the following conditions: Failure to routinely change oil and to maintain a clean filter, or **exceeding 70% duty cycle resulting in overheating and excessive wear and tear**, or exposing electrical components to rain or water, or installing the unit in a hostile environment such as acid vapors or any caustic or abrasive matter that may be ingested into the pump, or installing the unit in an enclosed area where lack of cooling ventilation is present, such as in boiler or equipment rooms where the ambient air exceeds 100°F.

Airbase Industries shall not be held liable for any malfunction of **BARE COMPRESSOR PUMP UNIT** caused by failure or improper use and/or maintenance of other compressor components manufactured by others.

2. GENERAL PROVISIONS: Airbase Industries (and each of its subsidiaries) is not responsible for downtime during warranty service. If downtime is necessary, it is the Purchaser's discretion and obligation (at Purchaser's expense) to have a redundant compressor. Warranty repairs shall not include freight costs. If necessary, the Purchaser is responsible for returning unit and/or applicable part(s) to Airbase Industries.

Exclusions include: service such as OIL CHANGES, FILTER REPLACEMENTS, GASKET TIGHTENING TO CORRECT OIL SEEPAGE or DRIVE BELT TIGHTENING and VALVE CLEANING and are not covered under warranty.

Further Exclusions include failure to fully and completely follow the guidelines set forth in the manual. Of specific note is where a product is used where granite and/or concrete work is performed or conditions are dusty and the product is required to be housed in a separate room from the adverse conditions where the product has access to fresh air intake.

Parts used for warranty purposes must be supplied by Airbase Industries. Warranty work will be performed by an approved Airbase Industries Technician. If any maintenance (other than routine maintenance) is performed by a non-approved Airbase Industries Technician, written pre-approval must be obtained from Airbase Industries to prevent voiding this Warranty. Failure to fully comply with this warranty and fully comply with the manual herein will void this warranty. All warranties are nontransferable.

The Oil Purchase Program is effective as of January 1, 2011.



Since 1977

Energy efficiency & MAXimum performance

Operating Instructions

ELECTRIC OPERATED, PISTON COMPRESSORS

EMAX designs and manufactures products for safe operation. However, operators and maintenance persons are responsible for maintaining safety. All safety precautions are included to provide a guideline for minimizing the possibility of accidents and property damage while equipment is in operation. **Keep these instructions for reference.**

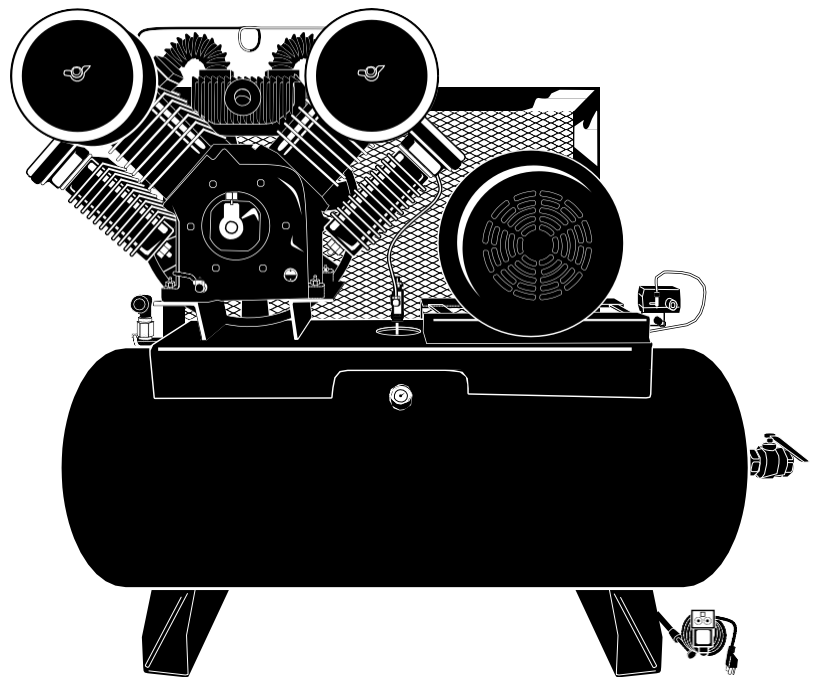
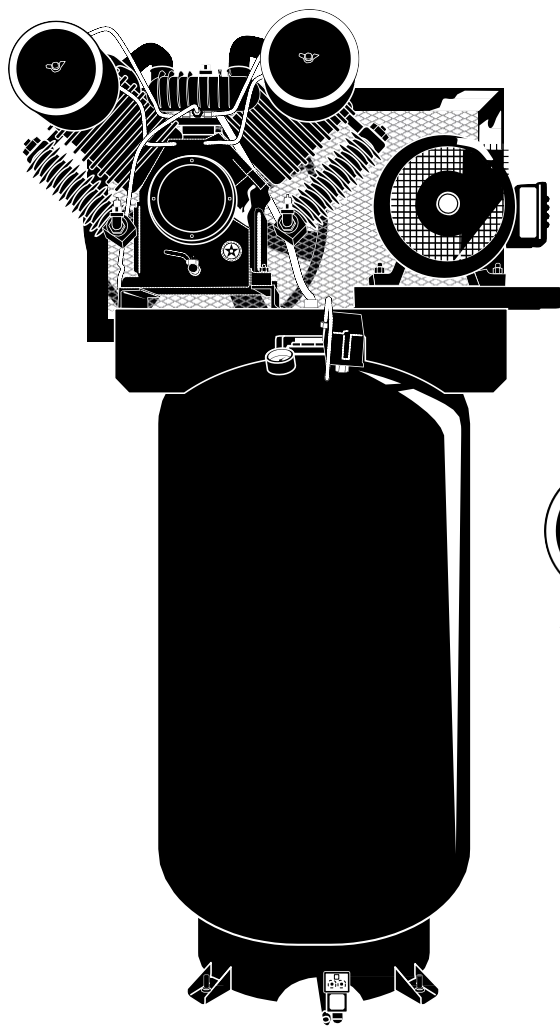

Contents

	Page No.		Page No.
Model Specification Charts	2-3	Operation	8
Description	3	Safety Rules	8
Safety Information	4	Start Up.....	9
Tag Definitions	4	Continuous Run Feature.....	9
Basic Guidelines	4	Maintenance	9
Breathable Air	4	Safety Steps	9
Pressurized Components.....	4	Belt Adjustment.....	10
Personal Protective Equipment.....	4	Changing Oil.....	10
Inspection	4	Safety Valve	10
Forklift Safety.....	5	Tank.....	10
Lifting Safety	5	Maintenance Schedule	11
Installation	5	Troubleshooting	11
Area.....	5	Warranty	12
Piping Safety	5		
Piping / Tank Installation	6		
Electronic Auto Drain (if equipped)	6		
Electrical Safety.....	7		
Wiring Installation	7		

EMAX Electric Operated, Two-Stage, 5-10 Hp Piston Air Compressors

Model	EP05H080I1	EP07H080V1	EP10H120Y1	EP07H080V3	EP10H120Y3
Tank Type	Horizontal	Horizontal	Horizontal	Horizontal	Horizontal
Dimensions <small>L*W*H (inches)</small>	76 x 30 x 56	76 x 30 x 56	78 x 32 x 50	76 x 30 x 56	78 x 32 x 50
Model	EP05V080I1	EP07V080V1	EP10V120Y1	EP07V080V3	EP10V120Y3
Tank Type	Vertical	Vertical	Vertical	Vertical	Vertical
Dimensions <small>L*W*H (inches)</small>	34 x 24 x 72	34 x 24 x 72	50 x 32 x 78	34 x 24 x 72	50 x 32 x 78
Tank Size	80 Gallon	80 Gallon	120 Gallon	80 Gallon	120 Gallon
Description	5HP Single Phase	7.5HP Single Phase	10HP Single Phase	7.5HP Three Phase	10HP Three Phase
SCFM @ 175 psi	17.0	26.0	35.0	26.0	35.0
Max PSI	175	175	175	175	175
Motor HP	5HP	7.5HP	10HP	7.5HP	10HP
Motor RPM	1750	1750	1750	1750	1750
Voltage	208V/230V	208V/230V	208V/230V	208/230/460/575	208/230/460/575
Pump Model	APP2I0524T	APP4V1043T	APP3Y1544T	APP4V1043T	APP3Y1544T
Pump RPM	650	640	600	640	600
Noise DB(A)	73	73	76	73	76
Outlet Connection	NPT 3/4"	NPT 3/4"	NPT 1"	NPT 3/4"	NPT 1"
Weight (±5 lbs.)	715	958	1095	958	1095
Shipping Weight	800	1043	1242	1043	1242

EMAX Electric Operated, Two-Stage, 15-25 Hp Piston Air Compressors

Model	EP15V120Y3	EP15H120Y3	EP20H120V3	EP25H120V3
Description	15 Hp Three Phase	15 Hp Three Phase	20 Hp Three Phase	25 Hp Three Phase
SCFM @ 175 psi	52.0	52.0	68.0	89.0
Max PSI	175	175	175	175
Motor HP	15 Hp	15 Hp	20 Hp	25 Hp
Motor RPM	1750	1750	1750	1750
Voltage	208/230/460/575	208/230/460/575	208/230/460/575	208/230/460/575
Tank Size	120 Gallon Vertical	120 Gallon Horizontal	120 Gallon Horizontal	120 Gallon Horizontal
Pump Model	APP3Y2062T	APP3Y2062T	APP4V2598T	APP4V2598T
Pump RPM	640	640	640	740
Noise DB(A)	76	76	78	79
Outlet Connection	NPT 1"	NPT 1"	NPT 1"	NPT 2"
Dimensions ^{L*W*H} (inches)	33 x 24 x 73	79 x 32 x 62	72 x 30 x 51	72 x 30 x 51
Weight (lbs.)	1410	1410	1500	1703
Shipping Weight	1512	1512	1609	1810

Description

*Unit configuration and appearance varies by model.
Callouts are for general identification.*

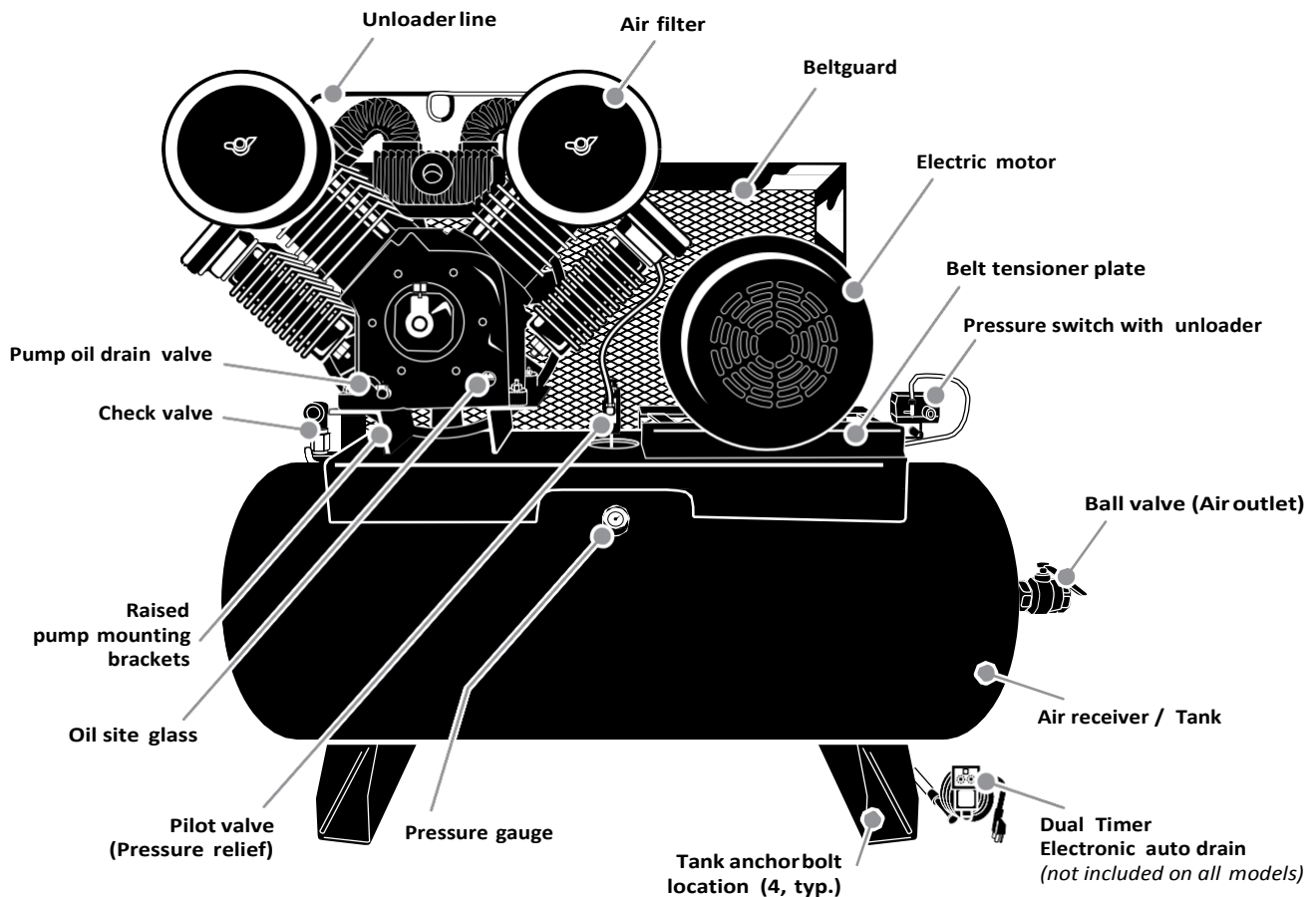

Safety

This manual contains very important information to know and understand. This is provided for SAFETY and to PREVENT EQUIPMENT PROBLEMS. To help understand this information, observe the following:

▲ DANGER Danger indicates an imminently hazardous situation which, if not avoided, *will* result in death or serious injury.

▲ WARNING Warning indicates a potentially hazardous situation which, if not avoided, *could* result in death or serious injury.

▲ CAUTION Caution indicates a potentially hazardous situation which, if not avoided, *may* result in minor or moderate injury.

NOTICE Notice indicates important information, that if not followed, may cause damage to equipment.



Read all manuals included with this product carefully. Be thoroughly familiar with the controls and the proper use of the equipment.

Basic Guidelines

CALIFORNIA PROPOSITION 65

▲ WARNING *This product or its power cord may contain chemicals known to the State of California to cause cancer and birth defects or other reproductive harm. Wash hands after handling.*

1. Allow only trained, authorized persons who have read and understood these operating instructions to use this compressor. Failure to follow the instructions, procedures and safety precautions in this manual can result in accidents and injuries.
2. NEVER start or operate the compressor under unsafe conditions. Tag the compressor, disconnect and lock out all power to it to prevent accidental start-up until the condition is corrected.
3. Install, use and operate the compressor only in full compliance with all pertinent OSHA regulations and all applicable Federal, State & Local Codes, standards and regulations.
4. NEVER modify the compressor and/or controls in any way.
5. Keep a first aid kit in a convenient place. Seek medical assistance promptly in case of injury. Avoid infection by caring for any small cuts and burns promptly.

Breathable Air

1. NEVER use air from this compressor for breathable air except in full compliance with OSHA Standards 29 CFR 1910 and any other Federal, State or Local codes or regulations.

▲ DANGER

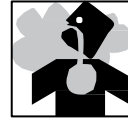

Death or serious injury can result from inhaling compressed air without using proper safety equipment. See OSHA standards on safety equipment.

2. DO NOT use air line anti-icer systems in air lines supplying respirators or other equipment used to produce breathable air. DO NOT discharge air from these systems in unventilated or other confined areas.

Pressurized Components

This equipment is supplied with a ASME designed pressure vessel protected by an ASME rated relief valve. Pull the ring *before each use* to make sure the valve is functional. Refer to figure 10. DO NOT attempt to open valve while the machine is under pressure.

Personal Protective Equipment

Be sure all operators and others around the compressor and its controls comply with all applicable OSHA, Federal, State and Local regulations, codes and standards relating to personal protective equipment. This includes respiratory protective equipment, protection for the extremities, protective clothing, protective shields and barriers, electrical protective equipment, and personal hearing protective equipment.

Inspection

▲ WARNING



Inspect compressor prior to any use. Check for external damage that might have occurred during transit. *Be careful of moving parts* then test pulley by turning it freely by hand. **Report any damage to delivery carrier immediately.**

▲ CAUTION

Make sure pallet-mounted compressors are firmly secured to the pallet before moving. NEVER attempt to move a compressor that is not secure as serious injury or property damage could occur.

A forklift may be necessary for unloading the EMAX compressor. Use all forklift safety measures and require a certified forklift operator. Refer to figure 1 for safe unloading procedure.

Forklift Safety

1. Make sure lift operator stays aware while moving compressor.
2. Be sure load is secure and well balanced before moving the compressor.
3. Make sure forks are fully engaged and level before lifting or moving compressor.
4. Keep load as low as possible and observe safe operating practices.

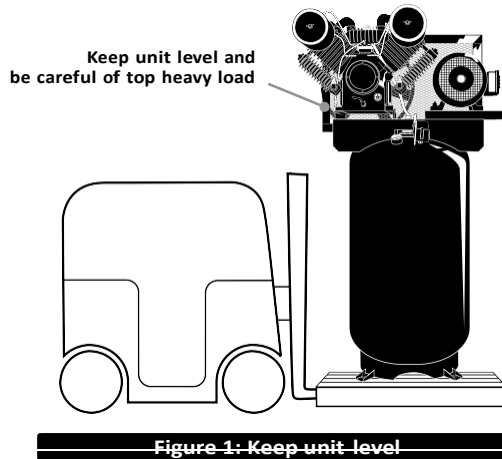

Lifting Safety

1. Carefully inspect all lifting equipment and make sure it is in good condition. Rated capacity should exceed compressor weight. Make sure lifting hook has a functional safety latch or equivalent and is properly attached to lifting feature.
2. Make sure lifting points are in good condition and tighten any loose nuts or bolts before lifting.
3. Use provided lifting feature or appropriate sling. A sling must be used when moving compressor with a helicopter or other air-borne equipment. Be sure to follow OSHA standards 29 CFR 1910 Subpart N.
4. Use guide ropes or equivalent to prevent twisting or swinging of the compressor while it is in the air and NEVER attempt to lift in high winds. Keep compressor as low to the ground as possible.
5. Keep persons away and make sure no one is under the compressor while it is lifted.
6. Only use lifting features provided for entire compressor package. NEVER use bolts or other hooks on individual components to move the compressor.
7. Make sure to put compressor on a level surface that can support the weight of the compressor and loading equipment.

▲ WARNING *Do not operate unit if damaged during shipping, handling or use.*

Damage may result in bursting and cause injury or property damage.

Installation

Area

1. Install compressor in a clean, dry and well-lit area. Be sure installation area can maintain a temperature range between 35° - 110° F.

▲ CAUTION *If ambient temperature drops below 32°F, be sure to protect safety/relief valves and drain valves from freezing. NEVER operate compressor with temperatures below 15°F or above 125°F.*

2. Allow sufficient space around compressor for maintenance access and adequate airflow. Mount unit with pulley towards wall and leave a minimum of 15 inches of clearance.
3. Use shims to level compressor if installation area is not flat. This will avoid excessive vibration and premature pump wear.

▲ DANGER *DO NOT install compressor in boiler room, paint spray room, or area where sandblasting occurs. Make sure inlet air is away from exhaust fumes or other toxic, noxious or corrosive fumes or substances.*



4. If acid is used in operating environment or air is dust laden, pipe intake to outside, fresh air. Increase pipe size by one size for every 20 feet of run. Be sure to install protective hood around intake filter.
5. In operating environments where excessive water, oil, dirt, acid or alkaline fumes are present, a TEFC (totally enclosed, fan cooled) motor is recommended. Check nameplate for motor type.
6. Insulate cold water or other low temperature pipes that pass overhead to avoid condensation dripping on compressor which could cause rust and/or motor shorting.

Piping

Safety Steps

1. Install appropriate flow-limiting valves as necessary according to pipe size(s) used and run lengths. This will reduce pressure in case of hose failure, per OSHA Standard 29 CFR 1926.302(b)(7).
2. Flow-limiting valves are listed by pipe size and rated CFM. Select appropriate valves accordingly, in accordance with the manufacturer's recommendations.

Piping / Tank Installation

1. Place tank feet on 1/4" thick rubber pads. Thicker padding will increase vibration and the possibility of cracking the tank or other unit damage. **Do not place unit on dirt floor or uneven surface.**
2. Fasten anchor bolts snugly but do not overtighten so normal vibration will not damage unit.

⚠ DANGER *Compressor unit is top heavy and must be bolted to solid, flat surface to avoid falling and premature pump wear. Splash lubrication will not operate properly if unit is not level.*

3. Use a flexible connector between compressor tank and piping system to minimize noise, vibration, unit damage, and pump wear.
4. Install appropriate ASME code safety valves and make sure piping system is equipped with adequate condensate drains. See figure 2. Refer to figure 3 for recommended closed loop installation.

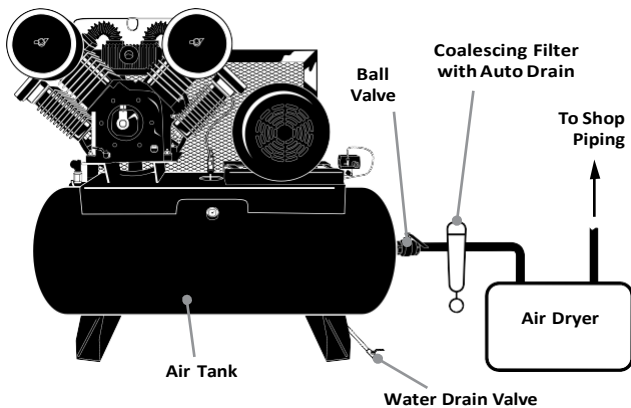

Figure 2: Basic Piping Diagram

⚠ WARNING *Never install a shut-off valve such as a glove or gate valve, between the pump discharge and the air tank unless a safety valve is installed in the line between valve and pump.*



5. Make sure any tube, pipe or hose connected to the unit can withstand operating temperatures and retain pressure.

⚠ WARNING *Never use plastic (PVC) pipe for compressed air. Serious injury or death could result.*

6. Never use reducers in discharge piping. Keep all piping and fittings the same size in the piping system.

Minimum Pipe Size For Compressed Air Lines
(Pipe size shown in inches)

SCFM	Length Of Piping System			
	25 ft.	50 ft.	100 ft.	250 ft.
20	3/4	3/4	3/4	1
40	3/4	1	1	1
60	3/4	1	1	1
100	1	1	1	1-1/4
125	1-1/4	1-1/4	1-1/2	1-1/2

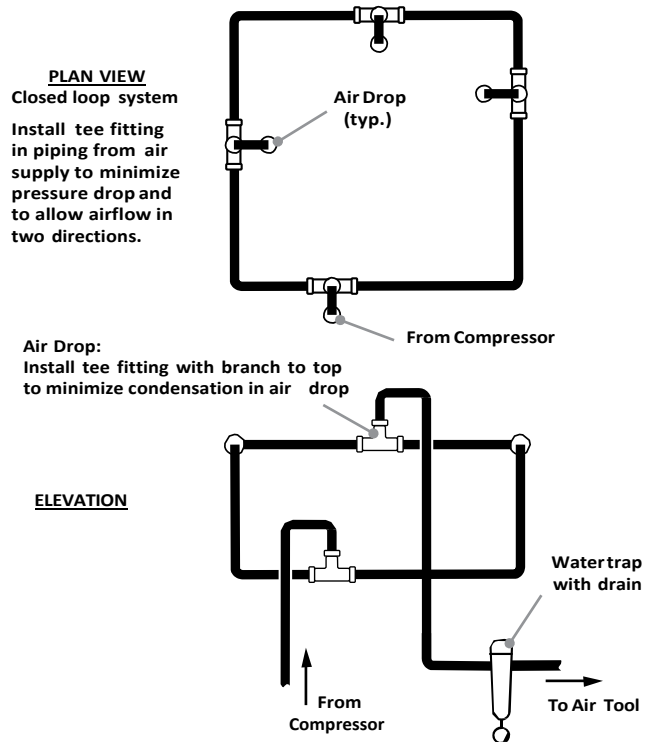

Figure 3: Closed Loop Installation

7. For permanent installations of compressed air systems, determine total length of system and select correct pipe size. Make sure underground lines are buried below frost line and avoid areas where condensation could build up and freeze.
8. Test entire piping system *before* underground lines are buried. Be sure to find and repair all leaks before using compressor.

⚠ WARNING *Never exceed recommended pressure or speed while operating compressor.*

Electronic Auto Drain (if equipped)

One auto drain can be used for multiple compressor units. Install necessary piping with appropriate fittings.

Not included on all units

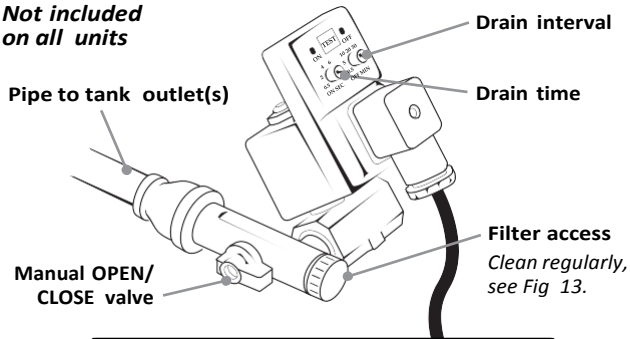

Figure 4: Auto Drain Feature

1. Plug auto drain into 120V outlet.
2. Set timers to desired settings. See figure 4. If drain is used for multiple units, increase timer settings as needed.
3. Use test button to check proper operation. Refer to maintenance section for proper care.

Electrical Safety



Be sure only trained and authorized personnel install and maintain this compressor in accordance with all applicable federal, state and local codes,

standards and regulations. Follow all NEC (National Electric Code) standards especially those concerning equipment grounding conductors.

1. Follow all NEC and local codes for electrical wiring. Allow only authorized EMAX service person or certified electrician to install electrical components.
2. Put unit on dedicated circuit and make sure no other electrical equipment is wired into it. Failure to wire unit on independent circuit can cause circuit overload and/or imbalance in motor phasing. Install proper No Fuse Breaker (NFB) according to kW output of compressor.
3. Ensure incoming service has adequate ampere rating.
4. Ensure supply line has the same electrical characteristics (voltage, cycles and phase) as the electric motor.
5. Refer to amp load information on motor tag and use correctly sized wiring. **Be sure to consider distance between power supply and machine.**
6. Install surge protection device between power supply and compressor motor.
7. Make sure to install properly sized breakers and fuses.
8. The unit must be properly grounded. **DO NOT** connect ground wire to air or cooling lines.

Ensure power supply and internal wiring is adequate According to voltage and frequency stated on motor nameplate and starter. Voltage should not vary more than

⚠ DANGER



Improperly grounded electrical components are shock hazards. Make sure all the components are properly grounded to prevent death or serious injury.

9. Make sure proper overload protection for the motor is installed.

Wiring Installation

Install power leads into terminals opposite motor Wires.

⚠ WARNING



When wiring unit with magnetic starter, do not install power directly to pressure switch to avoid possible fire and property damage.

12% to ensure proper operation of compressor.

Wire Sizes

5hp – use #8 wire

7.5hp – use #6 wire

10hp – use #4 wire

Single Phase Motors - No Magnetic Starter

1. Connect first power lead to 1L1.
2. Connect second power lead to 3L2.
3. Connect ground wire to existing motor ground wire.

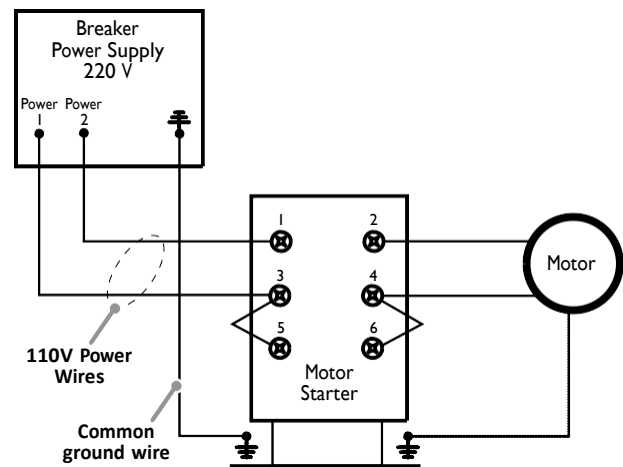

Figure 5: Single Phase Wiring Diagram without magnetic starter

Single Phase Motors - With Magnetic Starter

1. Connect first power lead to 1L1. Leave existing jumper wire installed. See Figure 6.
2. Connect second power lead to 3L2. Leave existing jumper wire installed.
3. Connect ground wire to ground lug.
4. Ensure all wiring and terminals are properly tightened.

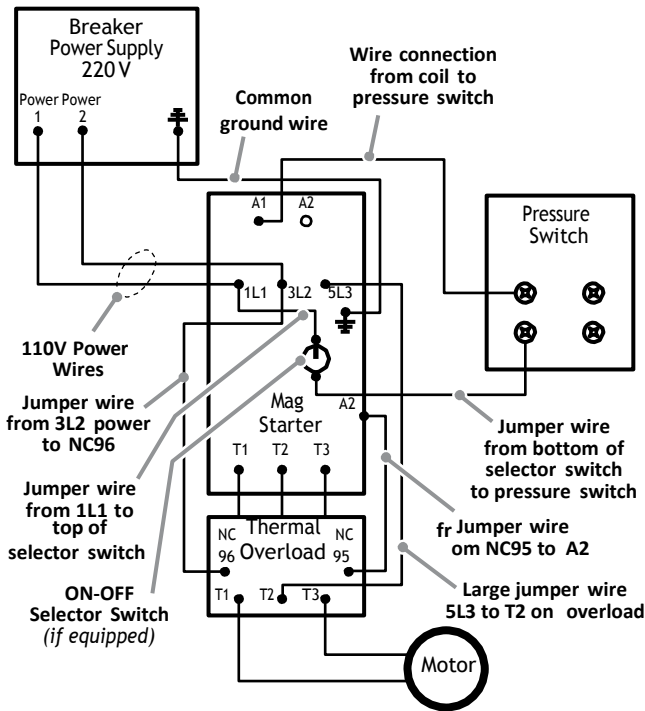

Figure 6: Single Phase Wiring Diagram with magnetic starter

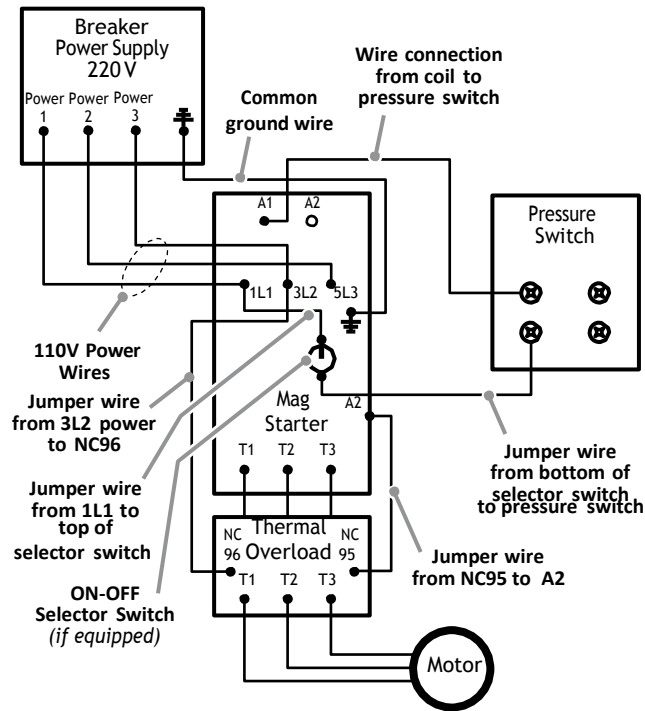

Figure 7: Three Phase Wiring Diagram with magnetic starter

Three Phase Motors (See figure 7)

1. Connect first power lead to 1L1.
2. Connect second power lead to 3L2.
3. Connect third power lead to 5L3.
4. Connect ground wire to existing motor ground wire.
5. Check for proper motor rotation. When facing motor shaft, pulley should turn counterclockwise. If rotation is reversed, **turn off power** then switch two power leads.

CAUTION Ensure wiring is installed according to voltage required for proper motor operation (220V or 460V).

Operation

Safety Rules

1. Make sure all operators receive product training, read and understand all instructions.

WARNING Keep all flammable, combustible, poisonous and noxious materials away from operating area. Make sure there are no oily rags, trash, leaves, litter or other combustible materials in operating area. Keep suitable, fully charged fire extinguishers nearby when servicing and operating the compressor.

2. NEVER allow modifications to compressor structure or controls.
3. Keep all ignition sources away from exposed electrical parts.
4. Keep all persons clear of compressor during start-up and operation.
5. NEVER operate the compressor with the fan, coupling or other guards removed.
6. DO NOT engage in horseplay with air hoses as death or serious injury may result.
7. Make sure to provide adequate ventilation and use proper lubricant while operating the compressor. If lubricant or other combustible substances are spilled, clean up immediately.
8. When checking or adding lubricant or when refilling air line anti-icer systems with antifreeze compound, shut off compressor and allow it to cool. Keep sparks, flames and other ignition sources away and DO NOT permit smoking in the vicinity.
9. Stop compressor and disconnect power if a hazardous condition arises.
10. Wear snug fitting clothing and confine long hair when around compressor. Keep all body parts and clothing away from couplings, flywheel and other moving parts of the equipment.

▲ WARNING



Keep all persons away from the discharge opening of hoses or tools or other points of compressed air discharge. If the machine is installed in an enclosed area, be sure to vent the relief valve outside

of the structure or to an unoccupied area.

11. DO NOT use air tools that are rated below the maximum rating of the compressor. Select air tools, air hoses, pipes, valves, filters and other fittings accordingly. DO NOT exceed manufacturer's rated safe operating pressures for these items.
12. Make sure all hose connections are adequately secured to prevent tools or hose ends from being accidentally disconnected.

Start-Up

1. This unit is shipped with pump break-in oil and should be ready to operate. Be sure to check for proper oil level before operating the compressor. Oil should be in center of site glass. See figure 8.

NOTICE

Use only Airbase Industries oil (PN: APOL0300G1). Use of any other product will cause product damage and void the warranty.

2. Check for proper belt tension. There should be 1/2 inch slack. Refer to maintenance section if adjustment is necessary.

▲ WARNING



Always make sure main power is off before touching belts or other moving parts of compressor.

3. Lightly push power switch to make sure system is working.
4. If motor shaft is not turning counter clockwise, disconnect power to terminal block then exchange any two of the three power leads. Re-check rotation.

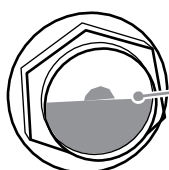

Oil level should be to center of red circle in site glass

Figure 8: Check proper oil level

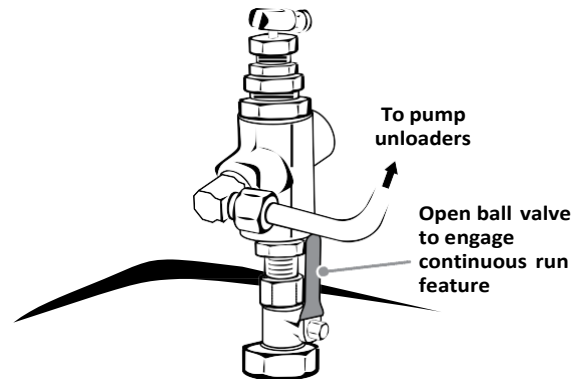

Figure 9: Continuous run feature

Continuous Run Feature (if equipped)

For heavy use applications such as sandblasting, the continuous run feature is available. This feature keeps main feed line open to eliminate numerous motor starts/stops and to help cool pump.

To engage continuous run feature, open ball valve found by following copper tubing across cylinder heads to tank. See figure 9.

Stop continuous run feature by closing valve so compressor will start and stop according to pressure switch.

Maintenance

Safety Steps

▲ WARNING



Disconnect, tag and lock out power source then release all pressure from the system before attempting to install, service, relocate or perform ANY maintenance.

1. Make sure repairs are done in a clean, dry, well lighted and ventilated area.
2. When cleaning, use air pressure less than 30 psig (2.1bar). NEVER use flammable solvents for cleaning purposes. Also use effective chip guarding and personal protective equipment per OSHA standard 29 CFR 1910.242 (b).
3. Relieve all internal pressure prior to opening any line, fitting, hose, valve, drain plug, connection or other component, such as filters and line oilers, and before refilling optional air line anti-icer systems with antifreeze compound.
4. Keep electrical wiring, including all terminals and pressure connectors in good condition. Replace any wiring that has cracked, cut, or otherwise damaged insulation. Replace terminals that are worn, discolored or corroded. Keep all terminals and pressure connectors clean and tight.

- Keep all body parts and any hand-held tools or other conductive objects away from exposed live parts of the electrical system. When making repairs or adjustments, stand on a dry, insulated surface and DO NOT contact any other portion of the compressor.
- DO NOT leave compressor unattended with exposed electrical components. Be sure to tag and disconnect all power if temporary absence is necessary.

CAUTION



Compressor components can become hot during operation. Avoid bodily contact with hot liquids, hot surfaces and sharp edges and corners.

Belt Adjustment

WARNING



Be sure to relieve all system pressure then lock out power and tag compressor to prevent unexpected movement of the unit.

Inspect belt tension after first 30 hours of operation then every 30 days.

- Proper belt tension is determined by pressing on belt midway between motor pulley and flywheel. There should be approximately 1/2 inch of deflection.
- Adjust belt tension as needed by loosening the four motor frame nuts then adjusting single bolt head on belt tensioner. See figure 11. **Remember to tighten motor bolts after adjustment is made.**
- Always replace all belts with the same brand, at the same time. Make sure belts are uni-matched. Do not replace belts independently.

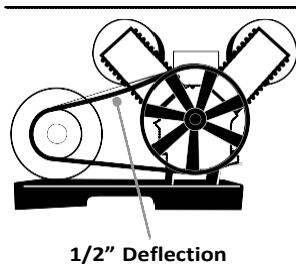

Fig. 10: Proper belt tension

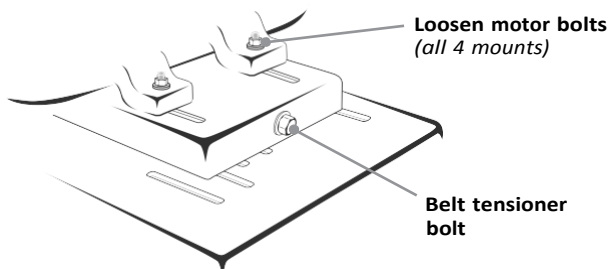
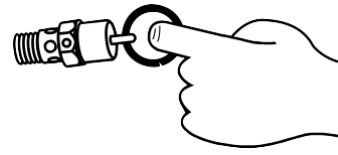

Figure 11: Belt adjustment



Pull ring on safety valve before each use.

Figure 12: Safety Valve

- Do not splash lubricating oil on belts or pulleys when adjusting or replacing belts.

Changing Oil

All units are shipped with break-in oil. Change oil within first 50 hours or 30 days of operation, whichever comes first. **DO NOT use automotive type oil.**

NOTICE

Use only Airbase Industries Oil. Use of any

other product will cause product damage and void the warranty.

Change oil every 90 days or if oil becomes milky.

Safety Valve

DANGER



NEVER attempt to regulate or tamper with safety valve. Valve is sealed and certified by ASME code and is designed to relieve system pressure when necessary.

Check proper operation of safety valve before each use. Refer to figure 12. If valve does not open manually, **replace immediately**. Discharge pressure is generally set at 175 PSI (12.1 bar). DO NOT attempt to open valve while machine is under pressure.

Tank

Drain daily.

If unit is equipped with electronic auto drain:

- Check daily to ensure proper operation.
- Clean filter daily. Refer to figure 13.

Not included on all units

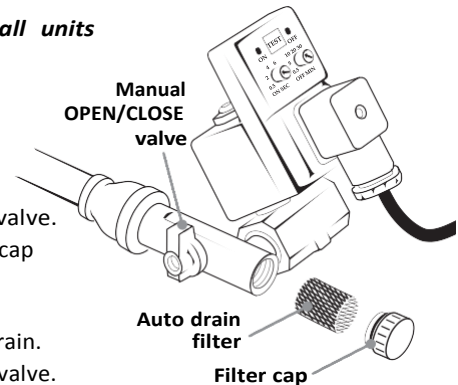

- Close manual valve.
- Remove filter cap and filter.
- Clean filter.
- Reassemble drain.
- Open manual valve.

Figure 13: Clean filter in automatic drain

Maintenance Schedule

Daily	<input type="checkbox"/> Check oil level <input type="checkbox"/> Check for unusual operation. Correct before damage occurs.	<input type="checkbox"/> Check safety valve <input type="checkbox"/> Drain tank and traps
Weekly	<input type="checkbox"/> Clean air filter <input type="checkbox"/> Change oil (<i>after first 50 hours</i>)	<input type="checkbox"/> General unit cleaning <input type="checkbox"/> Check for unusual operation. Correct before damage occurs.
Monthly	<input type="checkbox"/> Check and tighten all bolts as required <input type="checkbox"/> Check all connections for air leaks <input type="checkbox"/> Check belts for proper tension, wear, and alignment	<input type="checkbox"/> Inspect oil for contamination. Change if necessary. <input type="checkbox"/> Check all unloading lines for leaks. <i>Air leaks in unloader lines will cause unloaders and pilot valve to chatter and could cause short cycling of motor.</i>
Every 3 months	<input type="checkbox"/> Change oil	<input type="checkbox"/> Inspect valve assemblies

Troubleshooting Chart

Problem	Possible Causes	Resolutions
Low air pressure	<ol style="list-style-type: none"> 1. Clogged inlet filter 2. Air leak(s) in system 3. Application exceeds rated air output of compressor 4. Cylinder head valves not sealing 5. Insufficient power 	<ol style="list-style-type: none"> 1. Disassemble valve, clean thoroughly 2. Use soapy water to locate leaks, replace or tighten threaded parts 3. Check CFM requirements, change tool or use compressor with higher air output 4. Remove valves from cylinder head, repair or replace as necessary 5. Check power supply, rewire as necessary
Overheating	<ol style="list-style-type: none"> 1. Duty cycle exceeded 2. Improper rotation 3. Head valve(s) not seating properly 4. Blown cylinder head gasket(s) 5. Restriction in head, intercooler or check valve 6. Low oil 7. Dirt in intercooler fins or cylinder fins 8. Poor ventilation / ambient temperature too high 	<ol style="list-style-type: none"> 1. Keep duty cycle at 60/40 to maintain pump life 2. When facing flywheel, ensure counter-clockwise rotation 3. Clean or replace 4. Replace gasket(s) 5. Clear blockage 6. Add oil. Ensure oil level is at middle of site glass. See figure 8. 7. Use low pressure air to blow dirt away from compressor 8. Increase ventilation around operating area. Ensure compressor has adequate clear space from walls and other possible obstructions. Ambient temperature should not exceed 110° F.

NOTICE

Use only Airbase Industries Oil (PN: APOL03000G1). Use of any other product will cause product damage and void the warranty.

Warranty Statement

Emax, INC. (also known as EATON-MAX, Inc. and each of its subsidiaries) makes the following Warranties:

1. THAT EACH **ROTARY SCREW AIR COMPRESSOR PUMP** TO BE FREE FROM DEFECTS IN MATERIAL, WORKMANSHIP, AND PARTS FOR 10 YEARS ON THE ROTARY SCREW AIR COMPRESSOR PUMP FROM THE DATE OF PURCHASE. Emax (and each of its subsidiaries) is not responsible for downtime during warranty service. If downtime is necessary, it is the Purchaser's discretion and obligation (at Purchaser's expense) to have a redundant UNIT. This warranty applies to rotary screw rotors and bearings. The electric motor carries a five year warranty and a 2 year warranty on the rest of the compressor unit. The screw compressor MUST have Emax, Inc. Lubricant Synthetic exclusively, the same which must be purchased from Emax, Inc. (Mixing different brands of oil will void this warranty and cause the rotors to varnish). All air filters, oil filters, and oil separator filters must be purchased from Emax, Inc. and the screw compressor must have Emax, Inc. Synthetic Rotary Screw oil, purchased exclusively from Emax, or an Emax dealer, for this warranty to apply.

Annual participation in all oil programs are required by original purchaser of the unit outlined by the following:

- a) Purchase an oil sample kit for oil analysis by Emax or Emax Dealer.
- b) Oil sample kit contains 20 oil sample containers. One (1) oil sample is to be sent for analysis by an Emax oil analysis laboratory every six (6) months so oil can be tested twice yearly.
- c) Oil samples are obtained by draining ozs. of oil into container then mailing sample container to laboratory address provided in oil sample kit.
- d) The laboratory will perform an oil analysis then email a report to email address required when oil sample is provided.
- e) Provide annual proof of purchase for oil/filter service kit.
- f) Maintain proper oil level in unit at all times. If the unit runs out of oil, this warranty is void.

Failure of original purchaser to comply with any of the above conditions pertaining to oil analysis with void the complete unit warranty.

A full detailed maintenance schedule must be sent to Emax, Inc. once a year with the total service completed quarterly, outlining each air filter, oil filter and oil change with the total hours on the unit after each maintenance was performed.

Failure to fully comply with this warranty and fully comply with the manual herein will void this warranty.

Exclusions to this warranty also include all normal wear and tear items, including, but not limited to the bearings, rotors, valves, belts, shaft seal and load/unload solenoids.

2. THAT EACH **BARE COMPRESSOR PUMP UNIT** TO BE FREE FROM DEFECTS IN MATERIAL, WORKMANSHIP, AND PARTS FOR 5 YEARS FOR THE UNIT FROM THE DATE OF PURCHASE. Emax (and each of its subsidiaries) is not responsible for downtime during warranty service. If downtime is necessary, it is the Purchaser's discretion and obligation (at Purchaser's expense) to have a redundant UNIT. Warranty repairs shall not include freight costs. Purchaser is responsible for returning unit to Emax, Inc. This pump must have Emax Inc, lubricant Synthetic exclusively, the same which must be purchased from Emax Inc. (Mixing different brands of oils will void the pump warranty). A service kit must be purchased from Emax or an Emax dealer for this warranty to apply. Service kits contain an air filter and synthetic oil that must be changed annually. Annual proof of purchase of all oil programs must be maintained by the original purchaser of the compressor pump. If the unit runs out of oil, this warranty is void. Failure to fully comply with this warranty and fully comply with the manual herein will void this warranty.

Exclusions include: service such as OIL CHANGES, FILTER REPLACEMENTS, GASKET TIGHTENING TO CORRECT OIL SEEPAGE or DRIVE BELT TIGHTENING and VALVE CLEANING and are not covered under warranty.

Warranty shall be void under the following conditions: Failure to routinely change oil and to maintain a clean filter, or **exceeding 70% duty cycle resulting in overheating and excessive wear and tear**, or exposing electrical components to rain or water, or installing the unit in a hostile environment such as acid vapors or any caustic or abrasive matter that may be ingested into the pump, or installing the unit in an enclosed area where lack of cooling ventilation is present, such as in boiler or equipment rooms where the ambient air exceeds 100°F.

3. THAT EACH **COMPRESSOR UNIT** TO BE FREE FROM DEFECTS IN MATERIAL, WORKMANSHIP, AND PARTS FOR 5 YEARS FOR THE COMPRESSOR PUMP AND 2 YEARS ON THE REMAINDER OF THE UNIT FROM THE DATE OF PURCHASE. The UNIT also carries a 1-year labor warranty. Emax (and each of its subsidiaries) is not responsible for downtime during warranty service. If downtime is necessary, it is the Purchaser's discretion and obligation (at Purchaser's expense) to have a redundant compressor. Warranty repairs shall not include freight costs. Purchaser is responsible for returning unit to Emax, Inc. This pump MUST have Emax Inc. Lubricant Synthetic exclusively, the same which must be purchased from Emax, Inc. (Mixing different brands of oil will void this warranty). A service kit must be purchased from Emax or an Emax dealer for this warranty to apply. Service kits contain an air filter and synthetic oil that must be changed annually. Annual proof of purchase of all oil programs must be maintained by the original purchaser of the compressor unit. If the unit runs out of oil, this warranty is void. Failure to fully comply with this warranty and fully comply with the manual herein will void this warranty.

Exclusions include: service such as OIL CHANGES, FILTER REPLACEMENTS, GASKET TIGHTENING TO CORRECT OIL SEEPAGE or DRIVE BELT TIGHTENING and VALVE CLEANING and are not covered under warranty.

Warranty shall be void under the following conditions: Failure to routinely change oil and to maintain a clean filter, or **exceeding 70% duty cycle resulting in overheating and excessive wear and tear**, or exposing electrical components to rain or water, or installing the unit in a hostile environment such as acid vapors or any caustic or abrasive matter that may be ingested into the pump, or installing the unit in an enclosed area where lack of cooling ventilation is present, such as in boiler or equipment rooms where the ambient air exceeds 100°F.

4. THAT EACH **DRYER UNIT** TO BE FREE FROM DEFECTS IN MATERIAL, WORKMANSHIP, AND PARTS FOR 5 YEARS ON THE HEAT EXCHANGER AND 2 YEARS ON THE DRYER UNIT FROM THE DATE OF PURCHASE. Emax (and each of its subsidiaries) is not responsible for downtime during warranty service. If downtime is necessary, it is the Purchaser's discretion and obligation (at Purchaser's expense) to have a redundant DRYER UNIT. Warranty repairs shall not include freight costs. Purchaser is responsible for returning unit to Emax, Inc. Each **DRYER UNIT** must have a coalescing filter attached to the intake of the dryer to remove any oil or dirt before air enters the dryer. Failure to install coalescing filter will void the warranty.
5. GENERAL PROVISIONS: Emax (and each of its subsidiaries) is not responsible for downtime during warranty service. If downtime is necessary, it is the Purchaser's discretion and obligation (at Purchaser's expense) to have a redundant compressor. Warranty repairs shall not include freight costs. If necessary, the Purchaser is responsible for returning unit and/or applicable part(s) to Emax, Inc.

Exclusions include: service such as OIL CHANGES, FILTER REPLACEMENTS, GASKET TIGHTENING TO CORRECT OIL SEEPAGE or DRIVE BELT TIGHTENING and VALVE CLEANING and are not covered under warranty.

Further Exclusions include failure to fully and completely follow the guidelines set forth in the manual. Of specific note is where a product is used where granite and/or concrete work is performed or conditions are dusty and the product is required to be housed in a separate room from the adverse conditions where the product has access to fresh air intake.

Parts used for warranty purposes must be supplied by Emax, Inc. Warranty work will be performed by an approved Emax, Inc. Technician. If any maintenance (other than routine maintenance) is performed by a non-approved Emax, Inc. Technician, written pre-approval must be obtained from Emax, Inc. to prevent voiding this Warranty. Failure to fully comply with this warranty and fully comply with the manual herein will void this warranty.

All warranties are nontransferable.

The Oil Purchase Program is effective as of January 1, 2011.