

DAVIT CRANES

Instructions & Operation Manual

ISO 9001:2008
ISO/TS 16949 : 2009



**TO PREVENT SERIOUS INJURY, READ AND UNDERSTAND
ALL WARNINGS AND INSTRUCTIONS BEFORE USE.**

Due to continuing improvements, actual product may differ slightly from the product described herein.

Description

Davit cranes are perfect for permanent or portable installation. These cranes consist of an angled beam which pivots over a vertical axis. They can have fixed or adjustable booms, and are available in portable as well as stationary units. Davit cranes incorporate a hand operated and cable assembly for load handling. Independent bases (Optional-Sold Separately) allow you to move the davit crane from base to base, so one davit crane can serve more than one lift station. Standard davit cranes feature an electrostatic powder coating to resist corrosion. Galvanized and stainless steel models provide added protection in harsh environments.

Unpacking

After unpacking the crane, inspect carefully for any damage that may have occurred during transit. Check for missing or damaged parts. Shipping damage claims must be filed with carrier.

Davit Cranes Series 500 lb, 1,000 lb and 2,000 lb

Hand or power winch operation up to 2000 lb capacity

- Hand winch operated models include spur gear or worm gear hand winch with automatic disc brake for load control.
- The worm gear hand winch can be power driven with a maximum 400 rpm drill-motor. Not available for 500 LB series cranes.
- Corrosion resistant finish with electrostatic powder coating and corrosion resistant fasteners. Galvanized finish also available,
- Adjustable booms provide different height and reach combinations for various size loads.
- Crane rotates 360° on a pin and sleeve bearing in the base.
- Stainless steel models for long service life in corrosive environments, with stainless steel hand winch.
- Bases in Pedestal and Socket style.

Safe Warnings and Precautions

When using this crane, safety precautions should always be followed to reduce the risk of personal injury and damage to the crane.

- 1) Read and follow the guidelines set forth in this owner's manual. Keep the manual, and all decals adhered to the crane at all times.
- 2) Inspect all components of the crane according to owner's manual before operation.
- 3) Operators must be well trained in operating this crane, and should be properly dressed (hard hat, safety shoes and safety glasses, no loose clothing).
- 4) Operators must know the load and the load must not exceed the crane rated capacity.
- 5) The load must be clear of other objects and free to move. Make sure the load will not tip, spin, roll away, or in any way move uncontrollably.
- 6) Adjust the boom to proper position so that the load hook is centered over the load. Avoid side pulls which could damage the crane or cause the load to tip.
- 7) When adjusting the boom, set the boom angle a bit above horizontal and hold the boom extension firmly to avoid it sliding out of the boom causing damage or injury.

- 8) Keep at least 5 wraps of wire rope wound on the drum of the winch at all times, to serve as anchor wraps. With less than 5 wraps on the drum the wire rope could come loose, causing the load to fall off.
- 9) Keep hands away from sheaves, gears, wire rope, and other moving parts of the equipment.
- 10) Keep all unnecessary personnel away from the crane while in operation. Keep out of the path of the load.
- 11) Do not lift people. The crane is not designed for lifting people.
- 12) Stay Alert: Watch what you are doing. Use your common sense. Do not use this crane when you are tired, stressed or when under the influence of drugs, alcohol or medication.

Instructions for Installing the Crane

- A qualified professional should inspect or design the foundation to insure that it will provide adequate support.
 - Locate the crane so it will be visible during the entire operation.
- 1) CONSULT APPLICABLE CODES AND REGULATIONS for specific rules on installing the equipment.

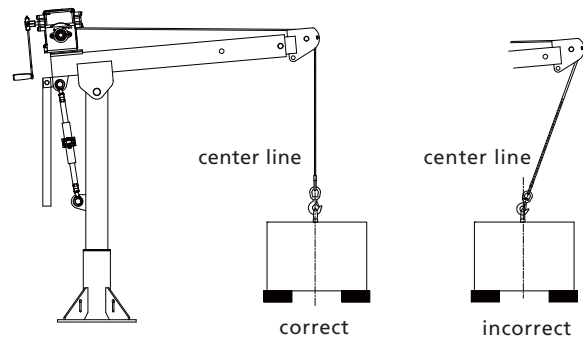

Figure 1

- 2) Locate the crane in an area clear of traffic and obstacles that could interfere with operation. Make sure the crane is accessible for maintenance and operation.
- 3) Install the crane on a level surface. An unlevel surface may cause the boom to rotate in the direction the mast is leaning.
- 4) Fasten the base securely to the foundation to withstand applicable overturning moments and mounting bolt reaction. See Table 1. For standard products referred to in this manual, use 3/8 inch or 5/8 inch coarse thread fasteners, grade 5 or better. Torque for 3/8 inch grade 5 fasteners without lubrication is 30 ft lbs, Torque for 5/8 inch grade 5 fasteners without lubrication is 150 ft lbs. Make sure mounting holes are secured to a solid foundation able to support the crane and the load under all conditions with design factors based on accepted engineering practices.

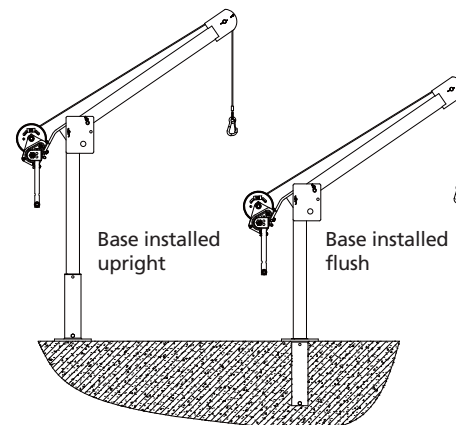

Figure 2A

Table 1 – Crane Reactions

Crane model	Mast moment		Suggested Bolt size	Axial force Pedestal Base only		Torque for grade 8.8 fasteners without lubrication
	in-lb	N.m		Lb	N	N.m
500 lbs	21,000	2,373	M10	2,121 lbs	9,435	40
1000 lbs	36,000	4,068	M16	1,756 lbs	7,811	200
2000 lbs	91,200	10,306	M16	4,447 lbs	19,781	200

Force in tension
Crane at 45°

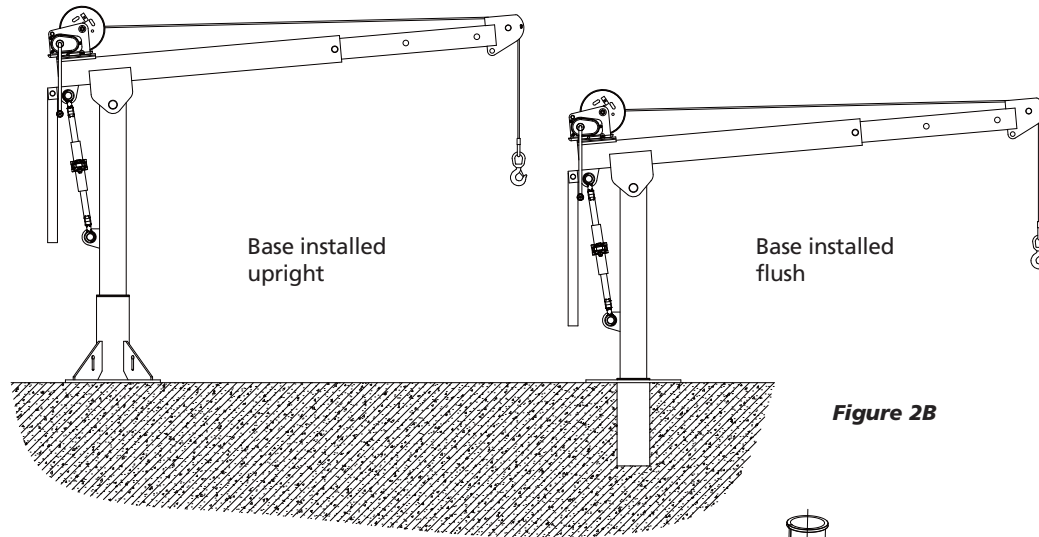

Figure 2B

Assembling the Crane For 500 Lb series cranes

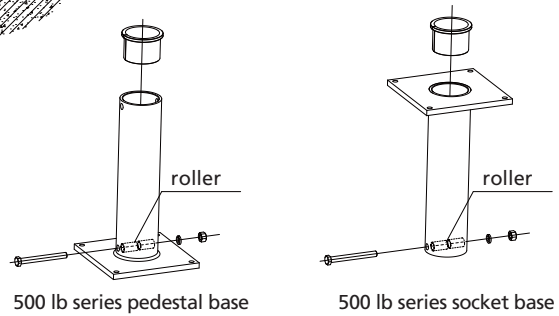

Figure 3

2. Put the mast into the base. This mast can rotate 360°. See Figure 4.

1. There are two different types of bases. One style is a pedestal and the other is a socket base. (Both of these are optional accessories) Before installing the base, fix the roller to the bottom of the base. After the base is installed, insert the nylon sleeve as shown in Figure 3.



Figure 4

3. Fasten the boom to the mast with the clevis pins provided. Secure the clevis pins in place with the hair cotter pins. Please view the picture below. There are two places marked as A and B on the left clevis pin. They function to regulate the crane angle. See Figure 5.

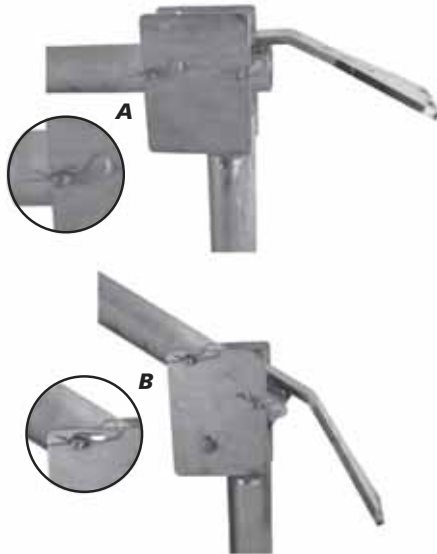

Figure 5

4. Attach the sheave to the boom using the clevis pin. Secure with cotter pin. See Figure 6.



Figure 6

5. At the very front sides of the boom, install the stop pin and put the hair cotter pin into the stop pin to secure it in place. See Figure 7.



Figure 7

6. Attach the hand winch to the mounting plate using hardware. See Figure 8.



Figure 8

7. Attach the handle to the hand winch. See Figure 9.



Figure 9

8. Installing the wire rope:

- 1) Pass the wire rope over the sheave at the end of the boom. See Figure 10.



Figure 10

- 2) Insert the steel cable through the square hole from inside to outside. Insert the steel cable into one side of the cable anchor. Insert the cable end into the other side of the cable anchor leaving a large loop outside. Tighten the nut slightly. Pull and reduce the loop down to the cable anchor. (See Figure.11)



Figure 11

Instructions for Assembling the 1,000lb/2,000lb Crane



Figure 14

1. There are two kinds of base : pedestal and socket. After installing the base, install the nylon sleeve on its top. See Figure 12.



pedestal base



socket base

Figure 12

2. Assembling the crane:

1) Install the mast in the base. Move the mast side to side to make sure the bottom of the mast properly seats on the pin in the bottom of the base. See Figure 13.



Figure 13

2) Fasten the boom to the mast with the clevis pin which is secured in place by the lynch pin. The lynch pin is fixed with the carrying handle by the wire rope. Pay attention that the carrying handle on the boom should be located on the same side as the handle on the mast. See Figure 14.



3) First adjust the ratchet jack to the greatest length and then install it when the boom is at horizontal position. Apply the clevis pins to secure the two ends of the ratchet jack to the mast and boom respectively. The clevis pins are fastened tight by the lynch pins. The lynch pins are fixed with carrying handles by the wire rope. See Figure 15.



Figure 15

4) Slide the boom extension into the boom and secure in place with the clevis pin and lynch pin provided. The lynch pin is fixed with the carrying handle by the wire rope. Please see the assembly drawing below. See Figure 16.



Figure 16

5) Attach the sheave with the clevis pin while using the cotter pin to prevent the clevis pin from falling off. Bend the cotter pin properly so as to secure itself in place. See Figure 17.



Figure 17

6) At the very front sides of the boom, install the stop pin and put the hair cotter pin into the stop pin to secure it in place. See Figure 18.



Figure 18

7) Install the handle on the lower end of the boom, applying the clevis pin and lynch pin provided. The lynch pin is fixed with the carrying handle by the wire rope. See Figure 19.



Figure 19

8) Secure the hand winch to the mounting plate (Figure 20) using hardware.



Figure 20

9) Install the handle onto the hand winch and tighten the fastening screw. See Figure 21.



Figure 21

10) Installing the wire rope:

- Pass the wire rope over the sheave at the end of the boom. See Figure 22.



Figure 22

- Insert the steel cable through the square hole from inside to outside. Thrust the steel cable into one side of the cable anchor. Insert the cable end into the other side of the cable anchor leaving a large loop outside. Tighten the nut slightly. Pull and reduce the loop down to the cable anchor. (See Figure.23)



Figure 23

Operation

1. The force required to lift the load must not exceed the load rating of the crane. Consider the total force required to lift the load, not the weight of the load.
2. This equipment can not develop forces that will exceed the load rating.
3. Performance ratings of the equipment are affected by the position of the boom. See the performance characteristics Tables 7D.
 - Load rating represents the maximum force that can be placed on new equipment. Load ratings are assigned values for specific boom positions and wire rope lengths. Crane load ratings decrease as you extend the boom.
 - Lift varies with the position of the boom and the length of the wire rope.
 - Reach varies with the position of the boom.
4. Duty ratings refer to the type of use the equipment is subject to. Consider the following when determining duty rating.
 - Environment: harsh environments include hot, cold, dirty, wet, corrosive, or explosive surroundings. Protect the equipment from harsh environments when possible.
 - Maintenance: poor maintenance, meaning poor cleaning, lubrication, or inspection, leads to poor operation and possible damage of the equipment. Minimize poor maintenance by carefully following the instructions contained in this manual.
 - Loading: severe loading includes shock loading and lifting loads that exceed the load rating of the equipment. Avoid shock loads, and do not exceed the load rating of the equipment.
 - Frequency of operation: frequent or lengthy operations increase wear and shorten the life span of gears, bearings, sheaves, and other components.

Maintenance:

LUBRICATING THE CRANE

Lubricate the crane properly to help protect it from wear and rust. Read the following instructions carefully.

- 1) Lubricate all pins before installation and at least every 3 months. Use a grease brush to apply a light film of NLGI #2 grease to all pins.
- 2) Lubricate the mast bearing before installation and at least every 3 months. Use a grease brush to apply a film of NLGI#2 grease to both inside and outside surfaces.
- 3) Lubricate the pin bushing located on the bottom of the mast before installation and at least every 3 months. Use a grease brush to apply a film of NLGI #2 grease to the bushing.
- 4) For (1000 lb/2000 lb) series crane, lubricate the ratchet jack before installation and at least every 3 months. Use a grease gun to apply an NLGI #2 grease to the grease fittings on the ratchet jack until excess grease can be seen.

LUBRICATING THE WINCH

- 1) Lubricate winch gears before every operation and at least every 10 hours during operation.
- 2) Lubricating the worm gear hand Winch
 - The winch is shipped from the factory with the proper amount (44 ounces) of Mobil gear 600 XP 220 lubricant in the gearbox. Lubricate the winch as follows, see Figures 24 and 25.

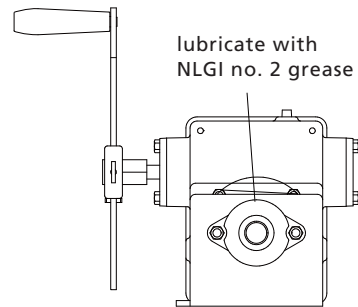

Figure 24

- Check oil level before every operation and every 10 hours during operation. Remove the level check plug and make sure oil is even with the plug hole. Add oil to the gearbox if necessary. Do not use synthetic lubricants and do not mix different lubricants. See Figure 25.
- Change gearbox oil at least every 6 months, or whenever it is dirty or contaminated. Remove the drain plug to drain oil from the gearbox. See Figure 25.
- Lubricate the outboard bearing at least once every month or more, depending on usage. Use a grease gun to insert NLGI no. 2 grease until clean grease appears at the seals. The bearing will squeak if it is dry. See Figure 24.

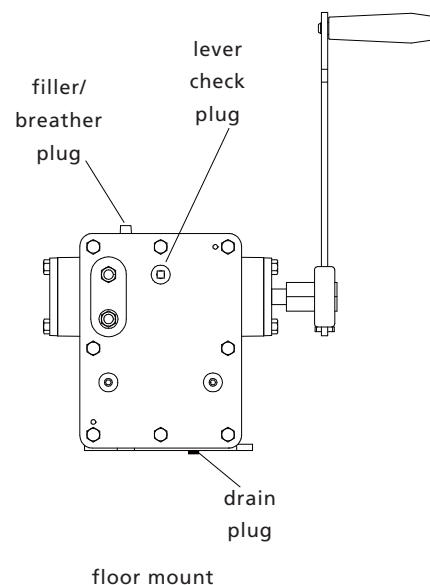

Figure 25

Storing the crane

Store the crane in a cool clean place away from corrosive chemicals and moisture.

Table 2A - (500lb , Red powder coat/galvanized) series crane weight chart

Component	Component weight		Assembly/disassembly weight(with pins)	
	LB	Kg	LB	Kg
Mast	30.9	14	—	—
Boom	34.4	15.6	—	—
Total	65.3	29.6	67	30.4

Table 2B - (500 lb, stainless) series crane weight chart

Component	Component weight		Assembly/disassembly weight(with pins)	
	LB	Kg	LB	Kg
Mast	28.7	13	—	—
Boom	30.4	13.8	—	—
Total	59.1	26.8	61	27.6

Table 2C - (1000 lb, Red powder coat/galvanized) series crane weight chart

Component	Component weight		Assembly/disassembly weight(with pins)	
	LB	Kg	LB	Kg
Mast	56.4	25.6	—	—
Boom	38.6	17.5	—	—
Boom extension	22.5	10.2	—	—
Ratchet jack	12.3	5.6	—	—
Handle	5.5	2.5	—	—
Total	135.3	61.4	138	62.6

Table 2D - (1000 lb, stainless) series crane weight chart

Component	Component weight		Assembly/disassembly weight(with pins)	
	LB	Kg	LB	Kg
Mast	55.1	25	—	—
Boom	40.8	18.5	—	—
Boom extension	27.1	12.3	—	—
Ratchet jack	12.3	5.6	—	—
Handle	6.6	3	—	—
Total	141.9	64.4	144.6	65.6

Table 2E - (2000 lb, Red powder coat/galvanized) series crane weight chart

Component	Component weight		Assembly/disassembly weight(with pins)	
	LB	Kg	LB	Kg
Mast	69.4	31.5	—	—
Boom	67.2	30.5	—	—
Boom extension	54.1	24.5	—	—
Ratchet jack	12.3	5.6	—	—
Handle	5.5	2.5	—	—
Total	208.5	94.6	214.5	97.3

Table 2F - (2000 lb, stainless) series crane weight chart

Component	Component weight		Assembly/disassembly weight(with pins)	
	LB	Kg	LB	Kg
Mast	77.4	35.1	—	—
Boom	90.4	41	—	—
Boom extension	59.1	26.8	—	—
Ratchet jack	12.3	5.6	—	—
Handle	6.6	3	—	—
Total	245.8	111.5	251.8	114.2

Table 3A - Spur gear hand winch performance characteristics

Description	Load rating(lb)			Wire rope dia. (in)	Drum capacity (ft) ²			Gear ratio	Force to lift 1000 lb	Approx. Ship Wt. (lb)
	1st layer	Mid drum	Full drum		1st layer	Mid drum	Full drum			
1000 lb-marine duty with brake	1000	700	500	3/16	3.8	19.4	50.4	3.1:1	36 lb	7
1000 lb-stainless steel with brake	1000	700	500	3/16	6	39	86	3.83:1	20 lb	15.4
2500 lb-marine duty with brake	2500	2000	1600	1/4	4.8	17	52	11:1	18 lb	15
2500 lb-stainless steel with brake	2500	2000	1600	1/4	4.8	17	52	11:1	18 lb	15
3500 lb-marine duty with brake	3500	2700	2000	1/4	6	30	91	18.4:1	13 lb	19.4

Table 3B - Worm Gear Hand Winch performance characteristics

Description	Load rating(lb)			Wire rope dia. (in)	Drum capacity (ft) ²			Gear ratio	Force to lift 1000 lb	Approx. Ship Wt. (lb)
	1st layer	Mid drum	Full drum		1st layer	Mid drum	Full drum			
2000 lb	2000	1500	1200	1/4	11	35	77	32:1	14 lb	36.65
	2000	1500	1200	5/16	8	25	52		14 lb	

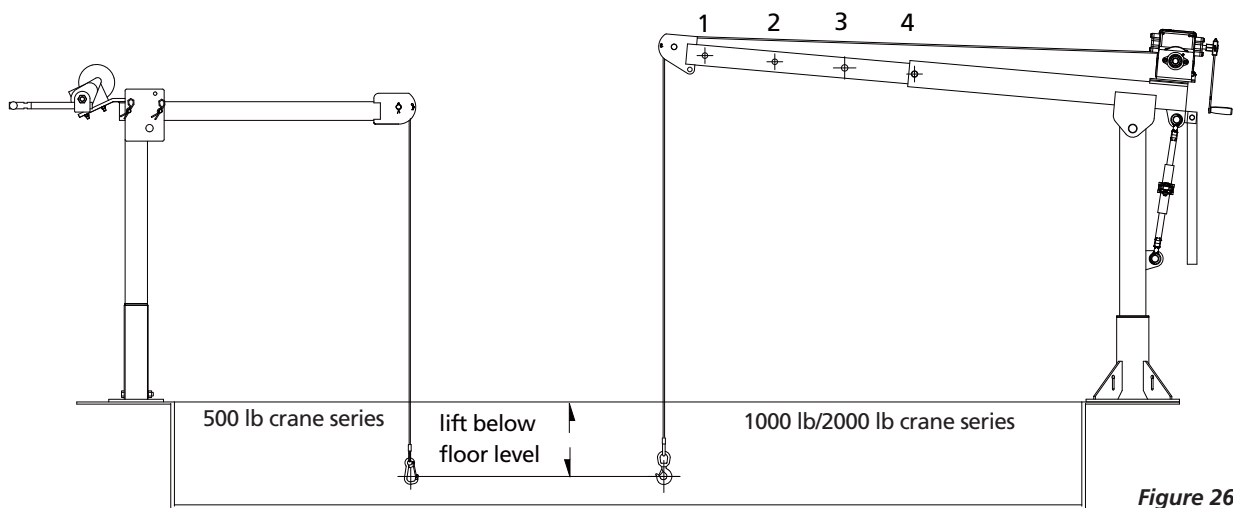

Figure 26

Table 4A - 500 lbs Series Performance Characteristics

wire rope dia.	wire rope length	500 lbs crane Series with winch RBW1000	500 lbs crane Series with winch RBW1000SS	Lift below floor level(min-max)
		Load rating Position	Load rating Position	
3/16 in	20 ft	500 lb	—	9-10 ft
3/16 in	45 ft	500 lb	—	34-35 ft
3/16 in	20 ft	—	500 lb	9-10 ft
3/16 in	45 ft	—	500 lb	34-35 ft

Table 4B - 1000 lbs Series Performance Characteristics

wire rope dia.	wire rope length	Load rating for 1000 lbs crane series with winch RBW2500				Load rating for 1000 lbs crane series with winch ROW2000				Load rating for 1000 lbs crane series with winch RBW2500SS				Lift below floor level (min-max)
		Position 1	Position 2	Position 3	Position 4	Position 1	Position 2	Position 3	Position 4	Position 1	Position 2	Position 3	Position 4	
1/4 in	36 ft	1000 lb	700 lbs	600 lbs	500 lbs	—	—	—	—	—	—	—	—	17-21 ft
1/4 in	60 ft	1000 lb	700 lbs	600 lbs	500 lbs	—	—	—	—	—	—	—	—	41-45 ft
1/4 in	36 ft	—	—	—	—	1000 lbs	700 lbs	600 lbs	500 lbs	—	—	—	—	17-21 ft
1/4 in	60 ft	—	—	—	—	1000 lbs	700 lbs	600 lbs	500 lbs	—	—	—	—	41-45 ft
1/4 in	36 ft	—	—	—	—	—	—	—	—	1000 lbs	700 lbs	600 lbs	500 lbs	17-21 ft
1/4 in	60 ft	—	—	—	—	—	—	—	—	1000 lbs	700 lbs	600 lbs	500 lbs	41-45 ft

Table 4C - 2000 lbs Series single-part ling Performance Characteristics

wire rope dia.	wire rope length	Load rating for 2000 lbs crane series with winch RBW3500				Load rating for 2000 lbs crane series with winch ROW2000				Lift below floor level(min-max)
		Position 1	Position 2	Position 3	Position 4	Position 1	Position 2	Position 3	Position 4	
1/4 in	36 ft	2000 lb	1600 lbs	1300 lbs	1000 lbs	—	—	—	—	16-20 ft
1/4 in	60 ft	2000 lb	1600 lbs	1300 lbs	1000 lbs	—	—	—	—	40-44 ft
1/4 in	36 ft	—	—	—	—	2000 lbs	1600 lbs	1300 lbs	1000 lbs	16-20 ft
1/4 in	60 ft	—	—	—	—	2000 lbs	1600 lbs	1300 lbs	1000 lbs	40-44 ft

ASSEMBLY DRAWING FOR 500 LB CAPACITY CRANES

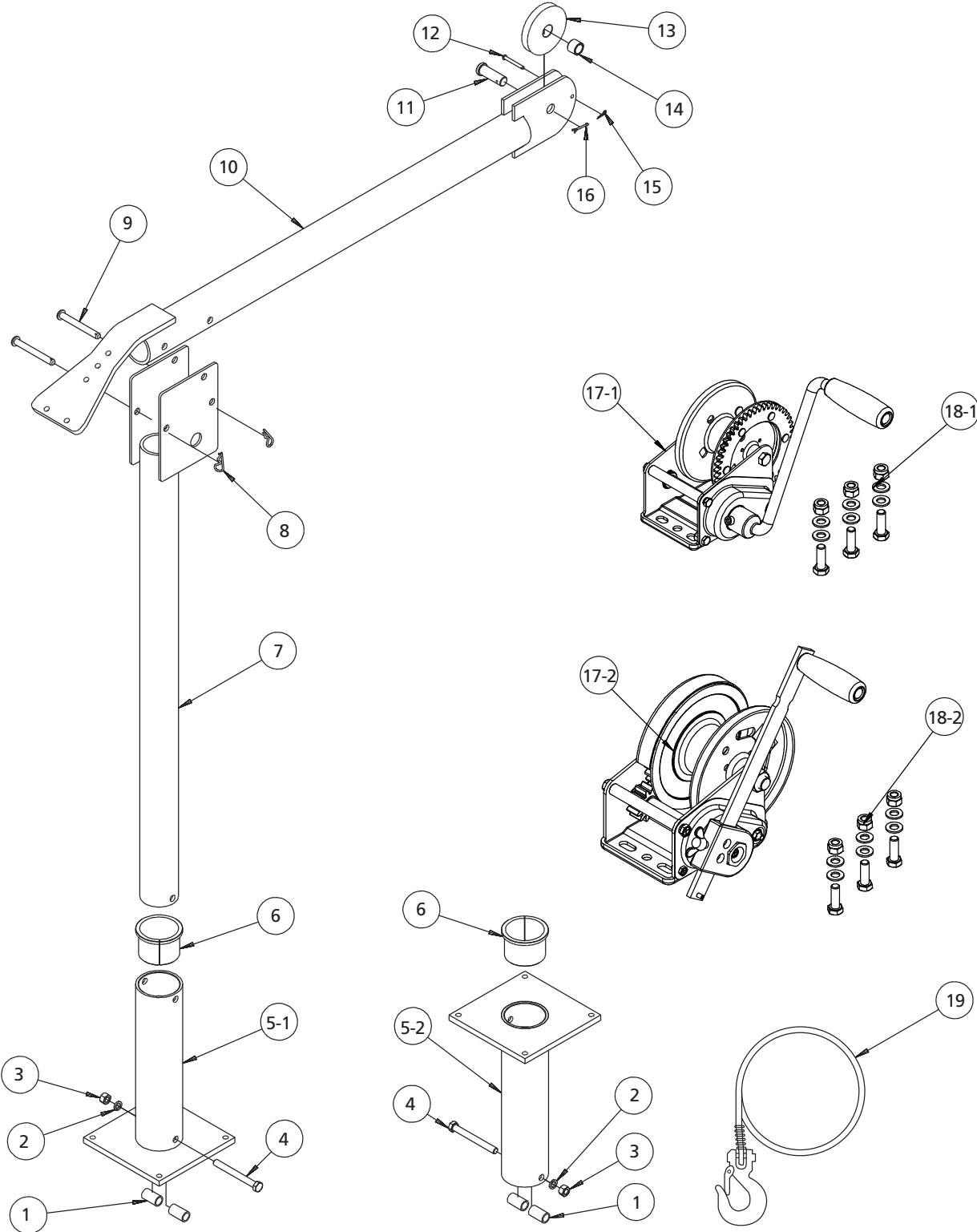

PARTS LIST FOR 500 LB CAPACITY CRANES

Item	Description	Qty
1	Copper Bush	2
2	Spring Washer M12	1
3	Nut M12	1
4	Bolt M12x110	1
5-1	Base	1
5-2	Socket	1
6	Fixed Sleeve	1
7	Mast Weldment	1
8	"R" Cotter Pin	2
9	12x100B Safety Pin	2
10	Movable Arm Weldment	1
11	Safety Pin	1
12	6x50B Safety Pin	1
13	Pully	1
14	Copper Bush	1
15	"R" Cotter Pin	1
16	Cotter Pin	1
17-1	Winch RBW1000 (For RC500P/RC500Z)	1
18-1	Bolt M10x30+Flat washer 10+ Nut M10 (For RC500P/RC500Z)	3
17-2	Winch RBW1000SS (For RC500S)	1
18-2	Stainless Bolt M10+Flat washer Ø10+ Nut M10x3 (For RC500S)	3
19	Cable Assembly	1

ASSEMBLY DRAWING FOR 1000 LB CAPACITY CRANES

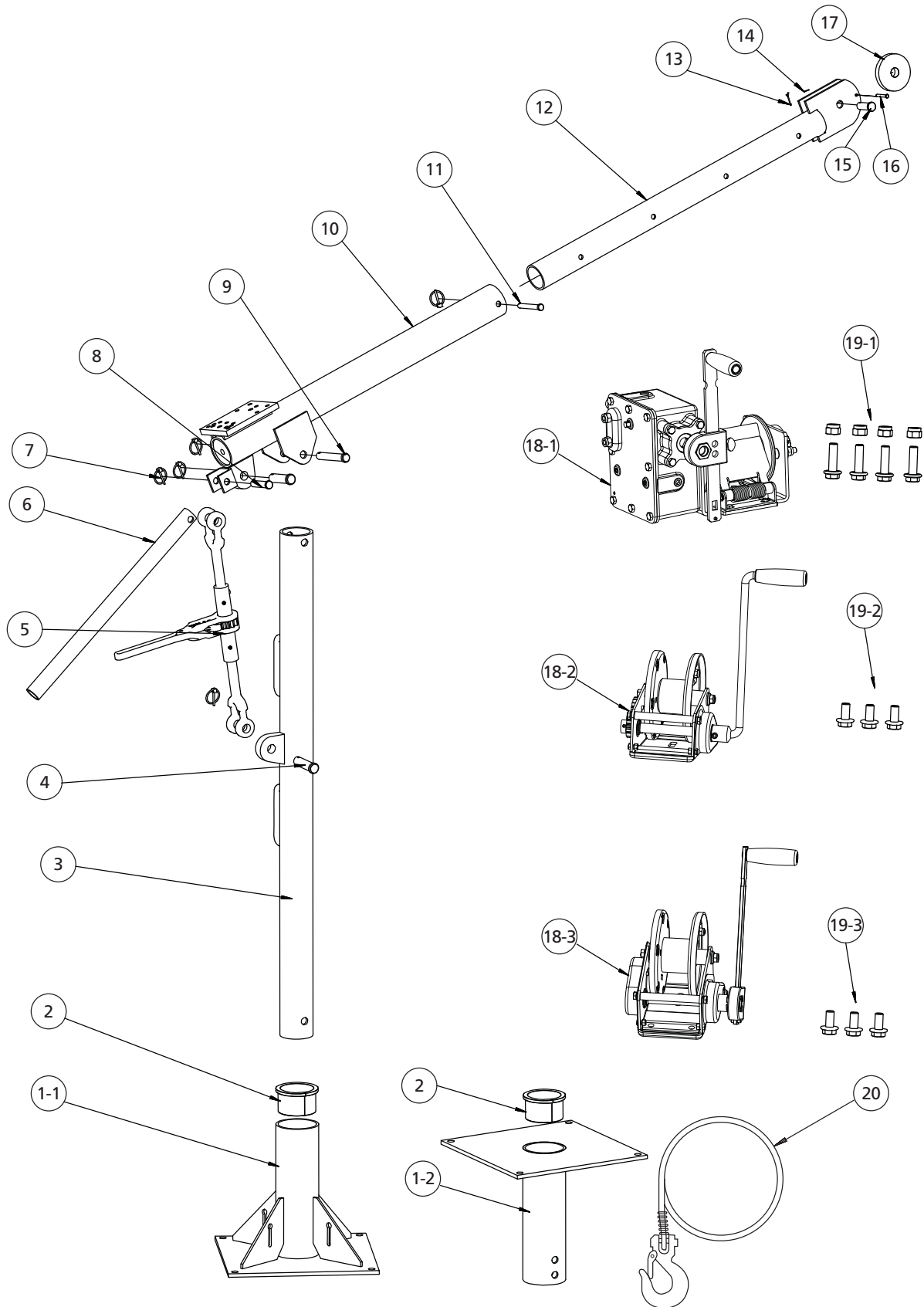

PARTS LIST FOR 1000 LB CAPACITY CRANES

Item	Description	Qty
1-1	Base	1
1-2	Socket	1
2	Fixed Sleeve	1
3	Mast	1
4	Ø16x75 Safety Pin	2
5	Ratchet Jack Assembly	1
6	Lever	1
7	Lockpin Assembly	5
8	Ø16x75 Safety Pin	1
9	Ø19x125 Safety Pin	1
10	Upper Bracket	1
11	Ø12.5x100 Safety Pin	1
12	Telescopic Bar Weldment	1
13	4x28 Lockpin	1
14	"R" Safety Pin	1
15	Ø19x55 Safety Pin	1
16	6x50B Pin with holes in the head	1
17	Pully Assembly	1
18-1	Winch ROW2000 (For RC1000P)	1
19-1	Bolt M10x34+Nut M10 (For RC1000P)	3
18-2	Winch RBW2500 (For RC1000Z)	1
19-2	Bolt M10x18 (For RC1000Z)	3
18-3	Winch RBW2500SS (For RC1000S)	1
19-3	Stainless Bolt M10x18 (For RC1000S)	3
20	Cable Assembly	1

ASSEMBLY DRAWING FOR 2000 LB CAPACITY CRANES

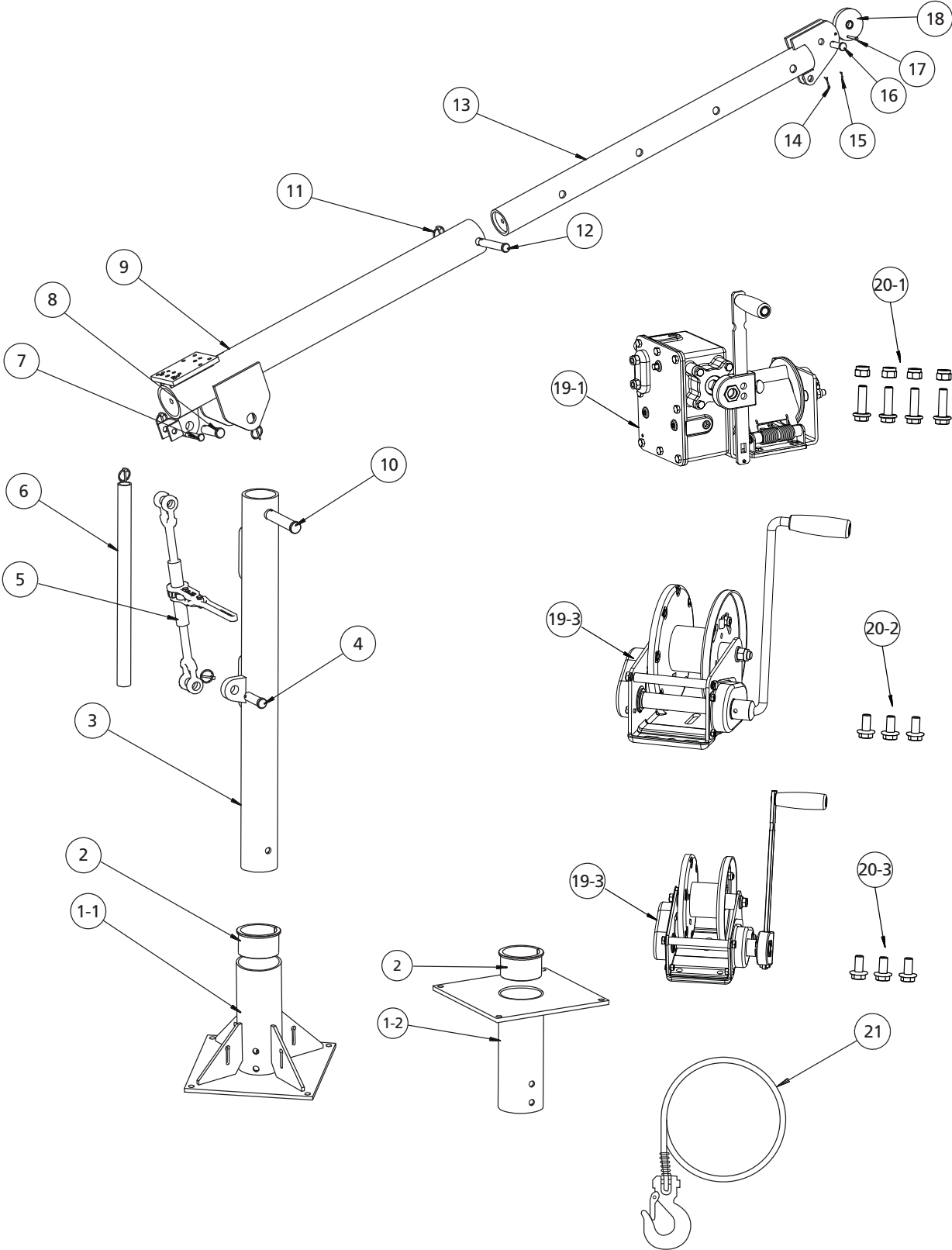

PARTS LIST FOR 2000 LB CAPACITY CRANES

Item	Description	Qty
1-1	Base	1
1-2	Socket	1
2	Fixed Sleeve	1
3	Mast	1
4	Safety Pin	1
5	Ratchet Jack Assembly	1
6	Lever	1
7	Ø16X75 Safety Pin	1
8	Ø27X85 Safety Pin	2
9	Upper Bracket	1
10	Ø32X154 Safety Pin	1
11	Lockpin Assembly	5
12	Ø23X135 Safety Pin	1
13	Telescopic Bar Weldment	1
14	3.2X28 Cotter Pin	1
15	1.2X12 Cotter Pin	1
16	Ø19X55 Safety Pin	1
17	6X50B Pin with holes in the head	1
18	Pully Assembly	1
19-1	Winch ROW2000 (For RC2000P)	1
20-1	Bolt M10x34+Nut M10 (For RC2000P)	3
19-2	Winch RBW3500 (For RC2000Z)	1
20-2	Bolt M12x18+Bolt M12x25 (For RC2000Z)	3
19-3	Winch RBW2500SS (For RC2000S)	1
20-3	Stainless Bolt M10x18 (For RC2000S)	3
21	Cable Assembly	1