

# Installation Manual for the



## MM-LPS13

### Slide Gate Operator System

**PROFESSIONAL INSTALLATION RECOMMENDED!**

#### **⚠ WARNING! ⚠**

This equipment is similar to other gate or door equipment and meets or exceeds Underwriters Laboratory Standard 325 (UL 325). However, gate equipment has hazards associated with its use and therefore by installing this product the installer and user accept full responsibility for following and noting the installation and safety instructions. Failure to follow installation and safety instructions can result in hazards developing due to improper assembly. You agree to properly install this product and that if you fail to do so Gates That Open, LLC, ("GTO") shall in no event be liable for direct, indirect, incidental, special or consequential damages or loss of profits whether based in contract tort or any other legal theory during the course of the warranty or at any time thereafter. The installer and/or user agree to assume responsibility for all liability and use of this product releasing Gates That Open, LLC, from any and all liability. If you are not in agreement with this disclaimer or do not feel capable of properly following all installation and safety instructions you may return this product for full replacement value.

**READ ALL INSTRUCTIONS CAREFULLY AND COMPLETELY** before attempting to install and use this automatic gate operator. This gate operator produces a high level of force. Stay clear of the unit while it is operating and exercise caution at all times.

All automatic gate operators are intended for use on vehicular gates only.



**DO NOT INSTALL THIS OPERATOR WITHOUT SAFETY EDGES or PHOTO BEAMS AND ROLLER GUARDS!**



This product meets and exceeds the requirements of UL 325, the standard which regulates gate operator safety, as established and made effective March 1, 2000, by Underwriters Laboratories Inc.



For more information on Mighty Mule's full line of automatic gate operators and access controls visit our website at [www.mightymule.com](http://www.mightymule.com).

**GTO Technical Service 8:00am–7:00pm (EST) • Monday–Friday  
1-800-543-1236 or (850) 575-0176 • Fax (850) 575-8912**

## Class Rating

The Mighty Mule MM-LPS13 Gate Operator is intended for use with **vehicular slide gates in single family residential applications**. The operator is system certified to be in compliance with UL 325, current edition, as of publication date.

### Vehicular Gate Operator Class Categories:

**Residential Vehicular Gate Operator—Class I:** A vehicular gate operator (or system) intended for use in a home of one-to-four single family dwellings, or a garage or parking area associated therewith.

**Commercial/General Access Vehicular Gate Operator—Class II:** A vehicular gate operator (or system) intended for use in a commercial location or building such as a multifamily housing unit (five or more single family units), hotel, garages, retail store, or other building servicing the general public.

**Industrial/Limited Access Vehicular Gate Operator—Class III:** A vehicular gate operator (or system) intended for use in an industrial location or building such as a factory or loading dock area or other locations not intended to service the general public.

**Restricted Access Vehicular Gate Operator—Class IV:** A vehicular gate operator (or system) intended for use in a guarded industrial location or building such as an airport security area or other restricted access locations not servicing the general public, in which unauthorized access is prevented via supervision by security personnel.

### *Converting Metric Units to English Equivalents*

<b>When You Know</b>	<b>Multiply By</b>	<b>To Find</b>	<b>Symbol</b>
centimeters	0.3937	inches	in. (or ")
meters	3.2808	feet	ft. (or')
kilograms	2.2046	pounds	lb. (or #)

### *Converting English Units to Metric Equivalents*

<b>When You Know</b>	<b>Multiply By</b>	<b>To Find</b>	<b>Symbol</b>
inches	2.5400	centimeters	cm
feet	0.3048	meters	m
pounds	0.4535	kilograms	kg

### *Converting Temperature*

deg. Celsius	$(^{\circ}\text{C} \times 1.8) + 32$	deg. Fahrenheit	$^{\circ}\text{F}$
deg. Fahrenheit	$(^{\circ}\text{F} - 32) \div 1.8$	deg. Celsius	$^{\circ}\text{C}$

## FOR YOUR RECORDS

Please record the following information product serial number (located on right side of the operator housing), be sure to **keep all receipts for proof of purchase**. Refer to this information when calling Mighty Mule for service or assistance with your automatic gate opener.

Serial Number: \_\_\_\_\_ Date of Purchase: \_\_\_\_\_

Place of Purchase: \_\_\_\_\_

# Table Of Contents

Class Rating .....	Inside Cover
Please Read This First .....	i
Important Safety Instructions.....	ii
Before You Begin.....	1
MM-LPS13 Technical Specifications.....	2
MM-LPS13 Parts Identification .....	3
Tools & Materials .....	4
Gate Operator Installation .....	5
Gate Preparation .....	5
Overview Of Operator Installation.....	5
Determining Mounting Options.....	6
Concrete Pad.....	6
Post Mount Adapter Plate (R4983).....	6
Adjustable Pad Mount Adapter Plate (R4984) .....	6
Determining Operator Mount Position .....	7
Using The Mounting Template .....	9
Determining The Chain Length.....	10
Powering The System.....	11
Connecting The Battery.....	11
Installation Of The Transformer.....	11
Connecting Solar Panel(s).....	12
Connecting The Receiver .....	12
DIP Switch Control Board Settings .....	12
Determining The Gate's Open Position .....	13
Adjusting The Limit Switches.....	14
Adjusting The Potentiometers.....	15
Programming Your Personal Transmitter.....	16
Mounting The Receiver .....	17
Connecting Safety Devices .....	18
Input Connections .....	19
Connecting Accessories.....	20
Attaching The Housing.....	21
Warranty And Repair Service .....	21
Troubleshooting Guide.....	22
Maintenance .....	23
Accessories .....	24

# PLEASE READ THIS FIRST

Thank you for purchasing a Mighty Mule MM-LPS13. When correctly installed and properly used, your MM-LPS13 operator will give you many years of reliable service. Please read the following information to ensure you have the correct system for your particular needs. This manual will enable you to properly install your MM-LPS13 Automatic Gate Operator.

The MM-LPS13 operator is designed for installation on a slide-to-open single leaf gate. The gate must not exceed 24 feet in length nor weigh more than 650 pounds (please see Technical Specifications on page 2). The MM-LPS13 operator can be used on vinyl, aluminum, chain link and wrought iron gates.

The MM-LPS13 operator accommodates extra transmitters, digital keypads, solar panels, push buttons, and other access control products. These optional accessories are noted with the  symbol.

The MM-LPS13 operator features **adjustable obstruction sense**. This safety feature makes the gate stop and reverse direction within two seconds when it comes in contact with an obstruction. The “MIN” setting means the gate will exert the minimum force on an obstruction before it stops and reverses direction.

The MM-LPS13 operator also has an **adjustable auto-close** feature. It can be set to remain open from 3 to 120 seconds before automatically closing. Pressing the transmitter button at any time after the gate fully opens will cause it to close immediately. “OFF” is the factory setting; meaning the gate will stay open until you press the transmitter button (or keypad, etc.) again.

Please call Mighty Mule at (800) 543-GATE [4283] or (850) 575-0176 for more information about our line of gate operators and accessories. Our Sales Department will be glad to give you the name and phone number of a Mighty Mule retailer near you.

## **BEFORE YOU BEGIN TO INSTALL YOUR AUTOMATIC GATE OPERATOR:**

**Read these instructions carefully and completely to become familiar with all parts and installation steps. You must read the installation manual for detailed instructions on gate operator safety and proper use of the gate operator.**



**24/7 Troubleshooting Wizard: <http://support.gtoinc.com>**



**Accessories are noted with this symbol in this Installation Manual. Information about accessories can be found on page 24.**

# IMPORTANT SAFETY INSTRUCTIONS



Because automatic gate operators produce high levels of force, consumers need to know the potential hazards associated with improperly designed, installed, and maintained automated gate operator systems. *Keep in mind that the gate operator is just one component of the total gate operating system.* Each component must work in unison to provide the consumer with convenience, security, and safety.

This manual contains various safety precautions and warnings for the consumer. Because there are many possible applications of the gate operator, the safety precautions and warnings contained in this manual cannot be completely exhaustive in nature. They do, however, provide an overview of the safe design, installation, and use of this product. **CAREFULLY READ AND FOLLOW ALL SAFETY PRECAUTIONS, WARNINGS, AND INSTALLATION INSTRUCTIONS TO ENSURE THE SAFE SYSTEM DESIGN, INSTALLATION, AND USE OF THIS PRODUCT.**

Precautions and warnings in this manual are identified with this  warning symbol. The symbol identifies conditions that can result in damage to the operator or its components, serious injury, or death.

**Because Mighty Mule automatic gate operators are only part of the total gate operating system, it is the responsibility of the installer/consumer to ensure that the total system is safe for its intended use.**

## How To Manually Open and Close the Gate:

 **CAUTION:** *Disconnect the operator chain ONLY when the power switch on the control box is turned off.*

### Disconnecting the Operator

1. Lift both the quick release pins UP, then pull them OUT of the chain brackets (see Illustration).
2. Lay the chain down and manually slide the gate to the desired position.

 **CAUTION:** *Because the Mighty Mule gate operator is battery powered, disconnect the operator ONLY when the power switch on the control box is turned OFF. Unplugging the transformer does not turn power to the operator OFF.*

**NOTE:** To prevent unauthorized removal of the quick release pins, install  [FM133] pin locks (see accessories on page 24) above the quick release pins in both chain brackets.

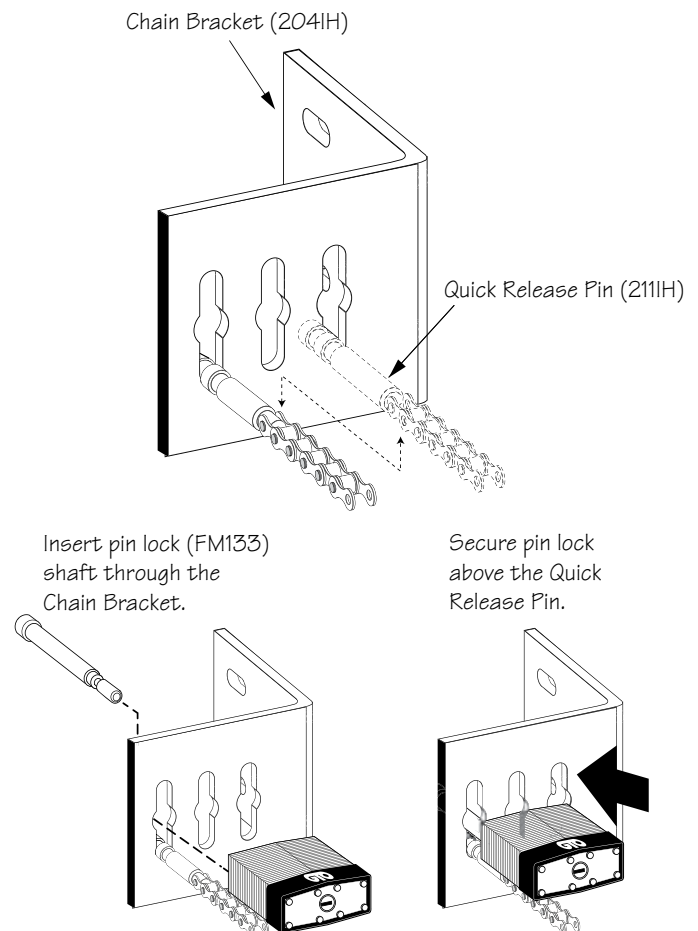



# IMPORTANT SAFETY INSTRUCTIONS

## For The Consumer

### **WARNING:** To reduce the risk of injury or death:

1. **READ AND FOLLOW ALL INSTRUCTIONS.** Failure to meet the requirements set forth in the instruction manual could cause severe injury or death, for which the manufacturer cannot be held responsible.
2. When designing a system that will be entered from a highway or main thoroughfare, make sure the system is placed far enough from the road to prevent traffic congestion.
3. The gate must be installed in a location that provides adequate clearance between it and adjacent structures when opening and closing to reduce the risk of entrapment.
4. The gate and gate operator installation **must comply with any applicable local codes.**

### **I. Before Installation**

1. Verify this operator is proper for the type and size of gate, its frequency of use, and the proper class rating.
2. Make sure the gate has been properly installed and slides freely in both directions. Repair or replace all worn or damaged gate hardware prior to installation. A freely moving gate will require less force to operate and will enhance the performance of the operator and safety devices used with the system.
3. Review the operation of the system to become familiar with its safety features. Understand how to disconnect the operator for manual gate operation (page ii).
4. This gate operator is intended for vehicular gates **ONLY**. A separate entrance or gate must be installed for pedestrian use (page vi).
5. Always keep people and objects away from the gate and its area of travel. **NO ONE SHOULD CROSS THE PATH OF A MOVING GATE.**

### **II. During Installation**

1. Install the gate operator on the inside of the property and fence line. **DO NOT** install an operator on the outside of the gate where the public has access to it.
2. Be careful with moving parts and avoid close proximity to areas where fingers or hands could be pinched.
3. **Devices such as contact sensors (safety edges) and non contact sensors (photo beams) provide additional protection against entrapment.**
4. If push buttons or keypads are installed, they should be within sight of the gate, yet located at least 10 feet from any moving part of the gate. **Never install any control device where a user will be tempted to reach through the gate to activate the gate operator.**
5. Do not activate your gate operator unless you can see it and can determine that its area of travel is clear of people, pets, or other obstructions. Watch the gate through its entire movement.
6. Secure outdoor or easily accessed gate operator controls in order to prohibit unauthorized use of the gate.

# IMPORTANT SAFETY INSTRUCTIONS



## III. After Installation

1. Attach the **warning signs** (*included*) to each side of the gate to alert the public of automatic gate operation. It is **your responsibility** to post warning signs on both sides of your gate. If any of these signs or warning decals become damaged, illegible or missing, replace them immediately. Contact GTO for free replacements.
2. The gate is automatic and could move at any time, posing a serious risk of entrapment. No one should be in contact with an activated gate when it is moving or stationary.
3. Do not attempt to drive into the gate area while the gate is moving; wait until the gate comes to a complete stop.
4. Do not attempt to “beat the gate” (drive through) while the gate is closing. This is extremely dangerous.
5. Do not allow children or pets near your gate. **Never let children operate or play with gate controls.** Keep ALL gate controls away from children and unauthorized users; store controls where children and unauthorized users do not have access to them.
6. **KEEP GATE AND GATE Operator PROPERLY MAINTAINED.** Always turn power to operator OFF before performing any maintenance. Regularly lubricate rollers.
7. To operate this equipment safely, YOU must know how to disconnect the operator for manual gate operation (page ii). If you have read the instructions and still do not understand how to disconnect the operator, contact the GTO Service Department.
8. Disconnect the operator **ONLY** when the power is **TURNED OFF** and the gate is **NOT** moving.
9. Make arrangements with local fire and law enforcement for emergency access.
10. Distribute and discuss copies of the **IMPORTANT SAFETY INSTRUCTIONS** section of this manual with all persons authorized to use your gate.
11. **IMPORTANT: Save these safety instructions. Make sure everyone who is using or will be around the gate and gate operator are aware of the dangers associated with automated gates. In the event you sell the property with the gate operator or sell the gate operator, provide a copy of these safety instructions to the new owner.**

Should you lose or misplace this manual, a copy can be obtained by downloading one from the Mighty Mule web site ([www.mightymule.com](http://www.mightymule.com)), by contacting Gates That Open, LLC., at 3121 Hartsfield Road, Tallahassee, Florida 32303 or by calling 1-800-543-4283 and requesting a duplicate copy. One will be provided to you free of charge.

## Required Safety Precautions for Gates

### Install Warning Signs

**Warning signs** alert people of automatic gate operation and are **required** when installing the Gate Operator. The Warning Signs included must be installed on both sides of each gate. Furthermore, a walk-through gate must be installed for pedestrian traffic.

### Entrapment Protection

Mighty Mule's inherent obstruction settings, even when properly adjusted, **may not be sensitive enough to prevent bodily injury in some circumstances.** For this reason, safety devices such as safety edge sensors (or photoelectric sensors), which stop and reverse gate direction upon sensing an obstruction, are required for enhanced protection against entrapment.



# IMPORTANT SAFETY INSTRUCTIONS

## Secondary Means of Protection Against Entrapment

As specified by Gate Operator Safety Standard, UL 325 (30A.1.1), automatic gate operators shall have an inherent entrapment sensing system, and shall have *provisions for, or be supplied with*, at least one independent secondary means to protect against entrapment. The MM-LPS13 utilizes **Type A**, an inherent (i.e., built-in) entrapment sensing system as the **primary** type of entrapment protection. Also, the MM-LPS13 has *provisions for* the connection of **Type B1 or B2** protection to be used as the **secondary** type of entrapment protection.

1. For gate operators utilizing a non-contact sensor (e.g., photo-electric sensor– Type B1) in accordance with UL 325 (51.8.4 [h]):
  - A. Refer to the sensor manufacturer's instructions on the placement of non-contact sensors for each type of application.
  - B. Care shall be exercised to reduce the risk of nuisance tripping, such as when a vehicle trips the sensor while the gate is still moving.
  - C. One or more non-contact sensors shall be located where the risk of entrapment or obstruction exists, such as the perimeter reachable by a moving gate or barrier.
2. For gate operators utilizing a contact sensor (e.g., safety edge sensor– Type B2) in accordance with UL 325 (51.8.4 [i]):
  - A. One or more contact sensors shall be located at the leading edge, bottom edge, and post edge, both inside and outside of a vehicular slide gate system.
  - B. A hard wired contact sensor shall be located and its wiring arranged so that the communication between the sensor and the gate operator is not subjected to mechanical damage.
  - C. A wireless contact sensor such as one that transmits radio frequency (RF) signals to the gate operator for entrapment protection functions shall be located where the transmission of the signals are not obstructed or impeded by building structures, natural landscaping or similar obstruction. A wireless contact sensor shall function under the intended end-use conditions.

You may want to consider adding photo beams to your installation. Photo Beams  [R4222] provide a “non contact” means of entrapment protection.

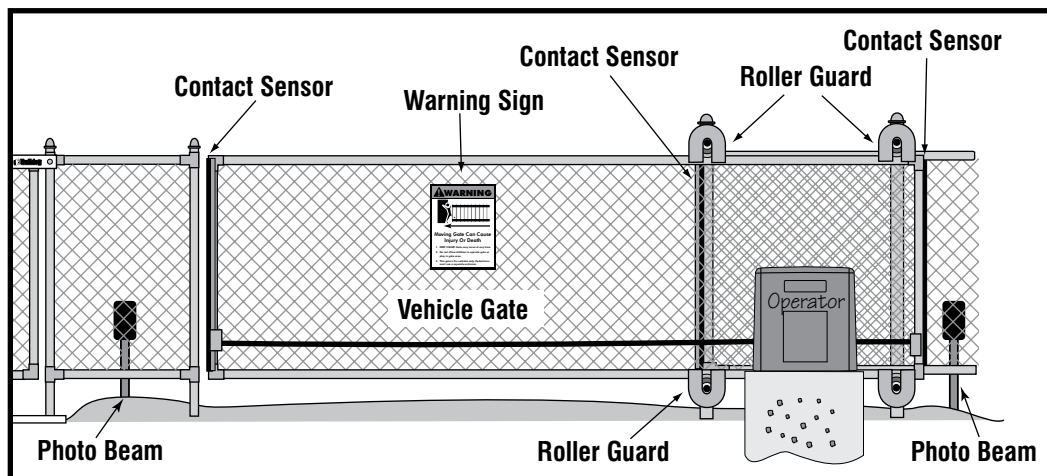

## ENTRAPMENT ALARM (UL 325; 30A.1.1A)

The MM-LPS13 Gate Operator is designed to stop and reverse within 2 seconds when the gate comes in contact with an obstruction. Additionally, these operators are equipped with an **audio entrapment alarm** which will activate if the unit obstructs **twice** while opening or closing. This alarm will sound for a period of 5 minutes, or until the operator receives an intended signal from a hard wired entry/exit source (e.g. push button control or keypad) and the gate returns to a fully open or fully closed position. Turning the power switch on the control box OFF and back ON will also deactivate the alarm. Wireless controls such as transmitters and wireless keypads will not deactivate the alarm.

# IMPORTANT SAFETY INSTRUCTIONS



## Install Screen Guard Over Gate and Fence

Injuries may occur when people place their hands, arms, legs, etc., through openings in the gate grill when the gate is operated, trapping them between the grill and the fence post (or fence). All openings of a horizontal slide gate must be guarded or screened to prevent a 2 ¼" diameter sphere from passing through openings anywhere in the gate. This screen/guard must also be installed over the portion of adjacent fence that the gate covers in the open position. Screening will prevent access through openings in areas where the gate may travel.

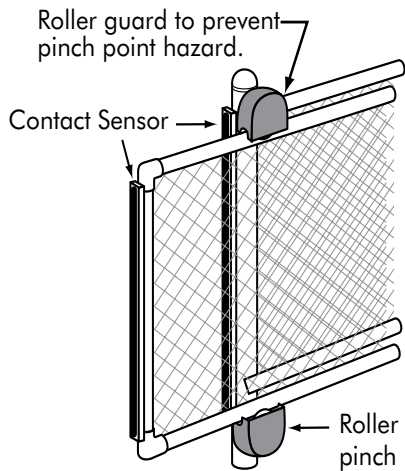
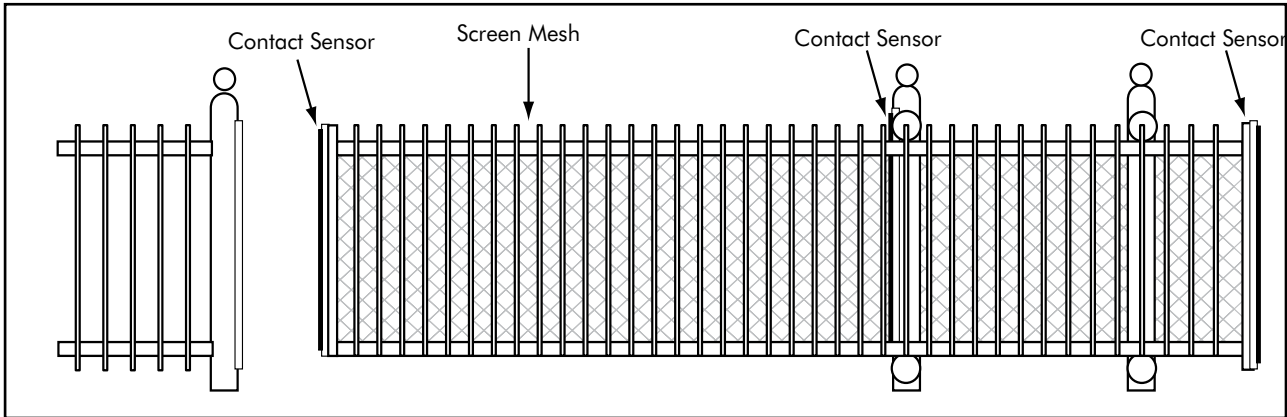

Injuries occur when people get their hands caught between the gate and the roller. Roller guards or enclosed tracks must be installed to prevent this pinch point hazard.



The warning signs (left) must be installed on both sides of the gate.

Mighty Mule's internal obstruction settings, even when properly adjusted, may not be sensitive enough to prevent bodily injury. For this reason, safety devices such as safety edges or photo beams MUST be installed. Furthermore, a pedestrian gate must be installed if walk-through traffic is expected near the gate.

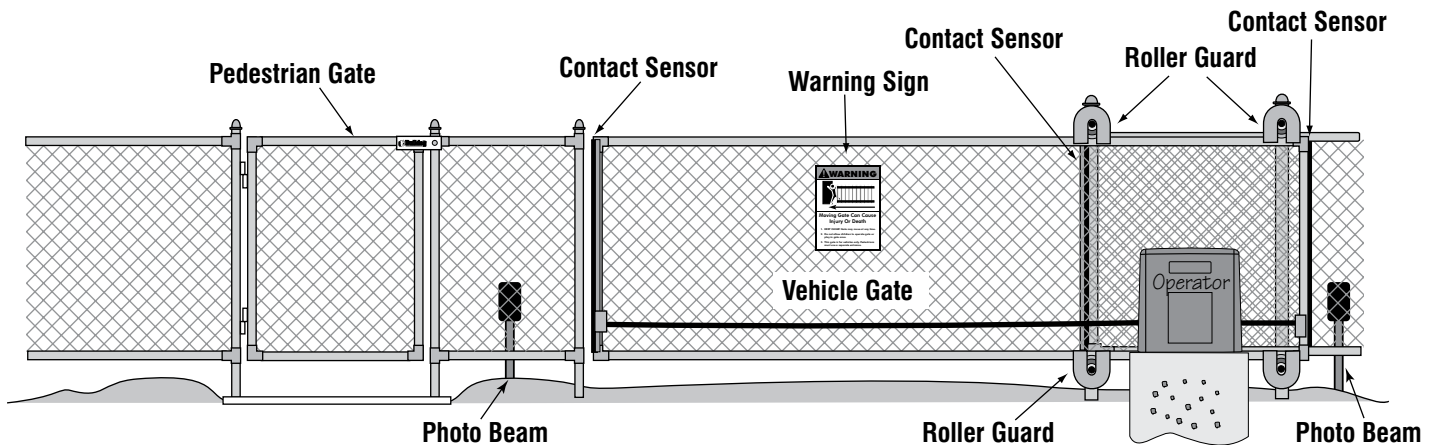



# IMPORTANT SAFETY INSTRUCTIONS

These warning labels should be found at the locations specified below. If any of them are missing, immediately contact the Technical Service Department at 1-800-543-1236 for replacements.

**! WARNING**

**Moving Gate Can Cause Injury Or Death**

1. **KEEP CLEAR!** Gate may move at any time.
2. Do not allow children to operate gate or play in gate area.
3. This gate is for vehicles only. Pedestrians must use a separate entrance.

Warning signs (2) to be installed on each side of the gate (3–5 feet above the bottom of the gate).

**MM-LPS13**  
**Conforms to UL 325 STANDARDS**  
**Certified to CAN/CSA-C22.2 No.247-92**

Maximum Gate: 650 lb. (294.8 kg); 24 ft. (7.3 m)  
Voltage: 12 Vdc; Frequency: 0 Hz; Power: 93.2 W  
Class I Vehicular Slide Gate Operator  
Serial Number: **MM-LPS13-xxxxxx**

---

**Disconnect operator ONLY when the gate is NOT moving.**

**TO MANUALLY OPEN AND CLOSE THE GATE:**

1. Lift quick release pins UP, then pull them OUT of chain brackets.
2. Lay chain down and manually slide gate to desired position.

Gates That Open, LLC. Tallahassee, Florida USA

Product identification and manual operation instruction label installed on outer housing.

**! WARNING**

- Adjusting limit switches with power on will activate gate.
- Injury may result if fingers get caught under switch plate while adjusting switches.
- Use extreme caution when adjusting switches.

Warning label located on right side of control box.

**! WARNING**

- Fingers, hands, and loose clothing may be dragged into chain sprockets.
- Fingers and hands can be injured by rotating sprockets.
- Keep hands, fingers, and loose clothing away from chain and sprockets.

Warning label located on top of control box.

**! WARNING**

- Fingers, hands, and loose clothing may be dragged into chain sprockets.
- Fingers and hands can be injured by rotating sprockets.
- Keep hands, fingers, and loose clothing away from chain and chain opening in operator housing.

1800-543-GATE (4283)  
[www.mightymule.com](http://www.mightymule.com)

R4258

Warning label located on front of operator housing.

# BEFORE YOU BEGIN...

## 1. Determine Charging Option for Battery: Transformer OR Solar

**NEVER USE TRANSFORMER AND SOLAR PANEL(S) AT THE SAME TIME.  
It will damage the control board.**

**IMPORTANT:**

- The MM-LPS13 12 volt battery ⊕[FM150] must be charged by either connecting the transformer (included) or solar panel kit ⊕[FM123] to the control board.
- The transformer is designed for indoor use. If the transformer can be plugged only into an outside electrical outlet, a weatherproof cover/housing (available at local electrical supply stores) must be used.
- All low voltage wire used with the Mighty Mule Gate Operator must be 16 gauge dual conductor, stranded, direct burial wire ⊕[RB509]. **Do not** run more than 1000 ft. of wire.
- If your gate is more than 1000 ft. from an AC power source, you will need to use at least 10 Watts solar charging power to charge the battery ⊕[FM123]. Refer to the Solar Panel and Gate Activity chart below.
- Two 12 volt batteries ⊕[FM150] are required for the MM-LPS13 to run on solar power. (see accessories on page 24)

### Solar Panel and Gate Activity Chart

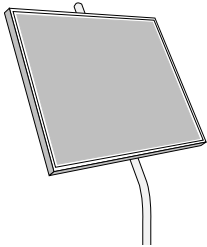

The table and map illustrate the maximum number of gate cycles to expect per day in a particular area when using from 10 to 20 Watts of solar charging power. The figures shown are for winter (minimum sunlight).

**Estimated Maximum Number of Cycles Per Day**

Winter Ratings	Watts	Zone 1	Zone 2	Zone 3
MM-LPS13	10	4	8	13
MM-LPS13	20	8	16	26

Accessories connected to your system will draw additional power from the battery.

**NOTE:** A minimum of 10 Watts, maximum of 20 Watts charging power is needed to charge the two batteries.

- ⊕ 10 Watt Solar Panel [FM123]
- ⊕ 5 Watt Solar Panel [FM121]

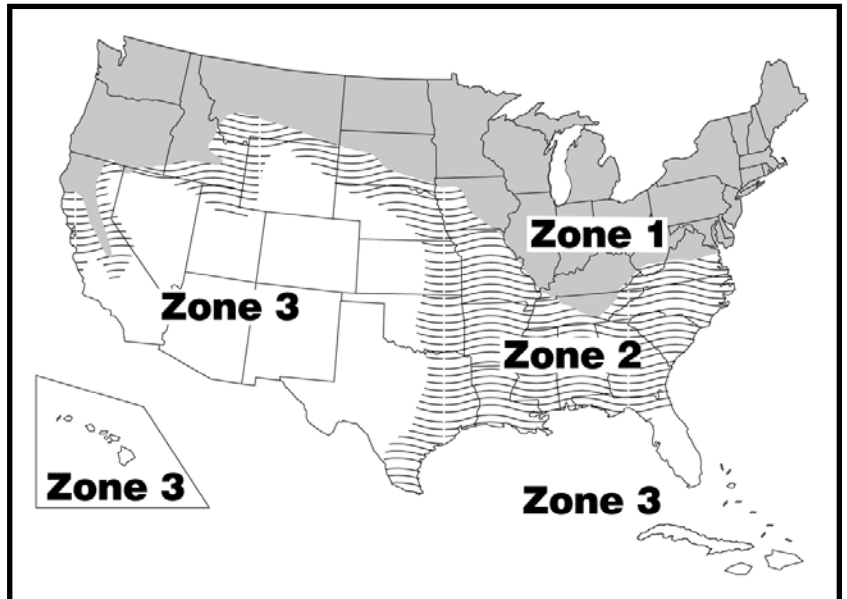

# MM-LPS13 TECHNICAL SPECIFICATIONS

## DRIVE

- Powered by a 1/4 hp 12 V motor with integral case hardened steel gear reducer. Motor speed reduced to 90 rpm.
- Gate velocity: 1 ft/second.

## POWER

- Two blade style fuses rated for 20 A.  
**NOTE: The transformer or the solar panel should not be connected directly to any battery.** Transformer must be connected to the control board with a minimum of 16 gauge, stranded, dual conductor, direct burial low voltage wire. Do not replace fuses with higher ampere rated fuses; doing so will void the warranty and may damage the control board.
- Solar charge maintained by Mighty Mule Solar Panel Charger.

## CONTROL

- Auto-memorization of digital transmitter code. Charging regulated by circuit on control board. "Sleep draw" is 40 mA; "active draw" is 5 to 13 A.
- Mighty Mule remote-mounted RF receiver tuned to 318 MHz.
- Limit controls are mechanical. Normally open contact.
- Adjustable auto-close timer (OFF 3 to 120 s), inertia, and obstruction sensitivity using three (3) potentiometers.
- Power terminal block accommodates a transformer or solar panels.
- Control board allows connection of safety edge sensors, photoelectric sensors, push button controls, digital keypads, loop detectors, etc.
- Audio entrapment alarm sounds if unit encounters an obstruction twice while opening or closing.

## OPERATIONAL RATINGS

- The Gate Capacity Chart shows approximate cycles, per day, you can expect from the MM-LPS13 Automatic Gate Operators when powered with a transformer. Actual cycles may vary slightly depending upon the type and condition of gate and installation.
- The MM-LPS13 will handle gates weighing up to 650 lb. (294.8 kg) and up to 24 ft. (7.32 m) in length (per leaf) if the proper installation procedures have been followed. Note that ball bearing rollers and covers should be used on all gates.
- Temperature range -5 °F to +120 °F.

*An operation cycle is on full opening and closing of the gate.*

Gate Opening	20 ft.	80	70
	16 ft.	100	90
	12 ft.	120	110
	8 ft.	140	130
		400 lb.	650 lb.
	Gate Weight		

\* These specifications are subject to change without notice.

To determine the number of cycles the gate opener will perform using solar panels, please see the specifications listed on page 1.

# MM-LPS13 PARTS IDENTIFICATION

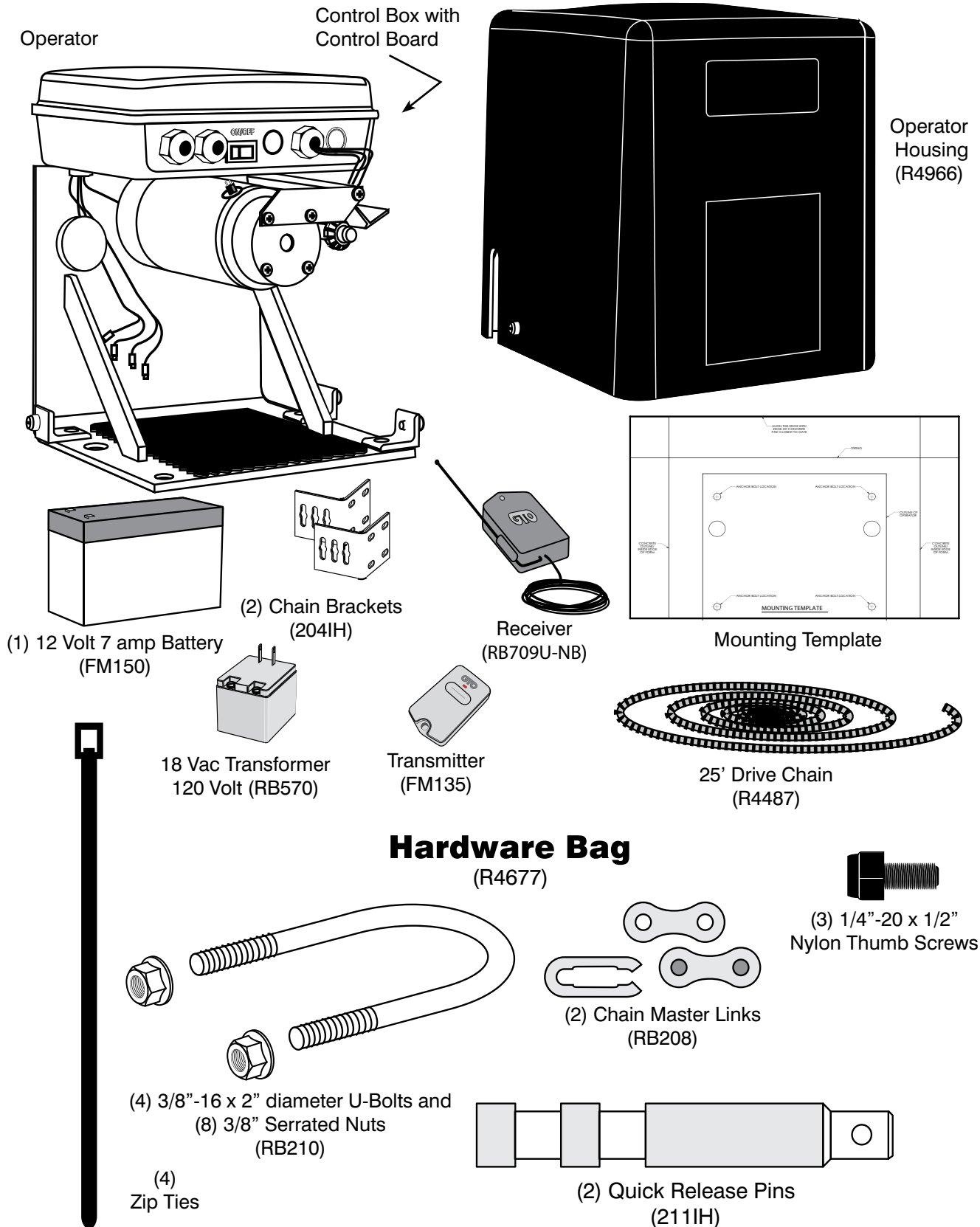

Parts available through GTO Technical Service at 1-800-543-1236

# TOOLS AND MATERIALS

## Tools Needed:

- Hammer Drill
- $\frac{3}{8}$ " Masonry Drill Bit
- Open End Wrenches
- Adjustable Wrench
- String & String Level
- Chain Break or Punch
- Plumb Bob
- Hacksaw or Heavy Duty Bolt Cutters
- Small Flat Bladed Screwdriver
- Large Phillips Screwdriver
- Tape Measure
- Level
- Wire Strippers
- C-Clamps — small, medium, and large
- Center Punch
- Extra person will be helpful

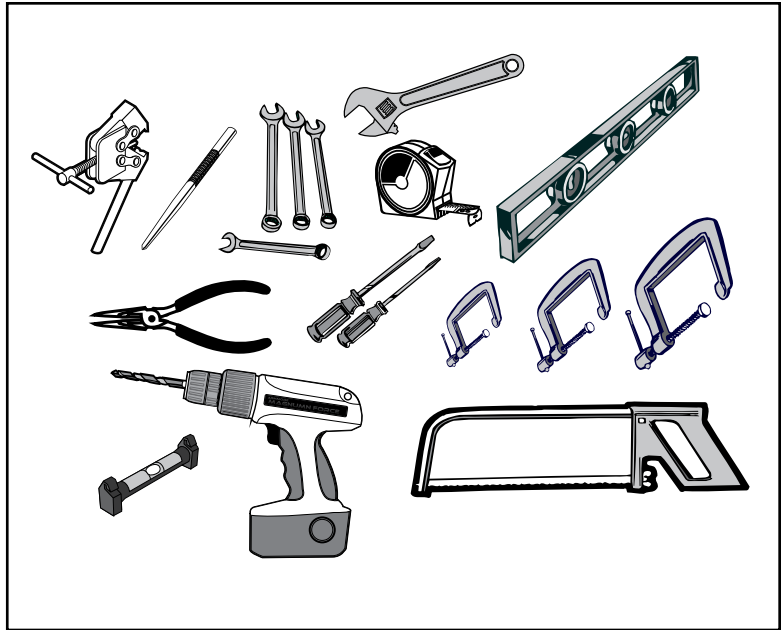

## Materials You May Need for the Installation:

These items are **NOT included** with the gate opener kit.

- Low voltage wire [RB509] will be needed to run from the transformer to the opener control board; length depends upon the distance between the transformer power supply and the control arm.
- If your gate is more than 1000' away from an AC power source you will need to use at least one 10 Watt solar panel [FM123] to charge the 12 Volt battery.
- Galvanized adjustable pad [R4983] or post mount [R4984] adapter (See accessories on page 24).
- PVC conduit for protecting wiring.
- Surge protection for transformer. (page 12)
- Weather proof outlet is required if transformer is plugged into outside outlet. (page 12)
- Four  $\frac{3}{8}$ " in diameter concrete mounting anchors.

## REQUIRED Items for the Installation:

These items are **NOT included** with the gate opener kit. These items can be purchased separately.

- Roller Guards (page v)
- Safety Edges (page v)
- Photo Beams (page v)

# GATE OPERATOR INSTALLATION

## Gate Preparation

Be sure the gate is properly installed and slides smoothly before installing the MM-LPS13 Slide Gate Operator. The gate must be plumb, level, and move freely. The gate must not bind or drag on the ground. Never use a wheel on the gate, because the additional drag and resistance can cause the operator to obstruct.

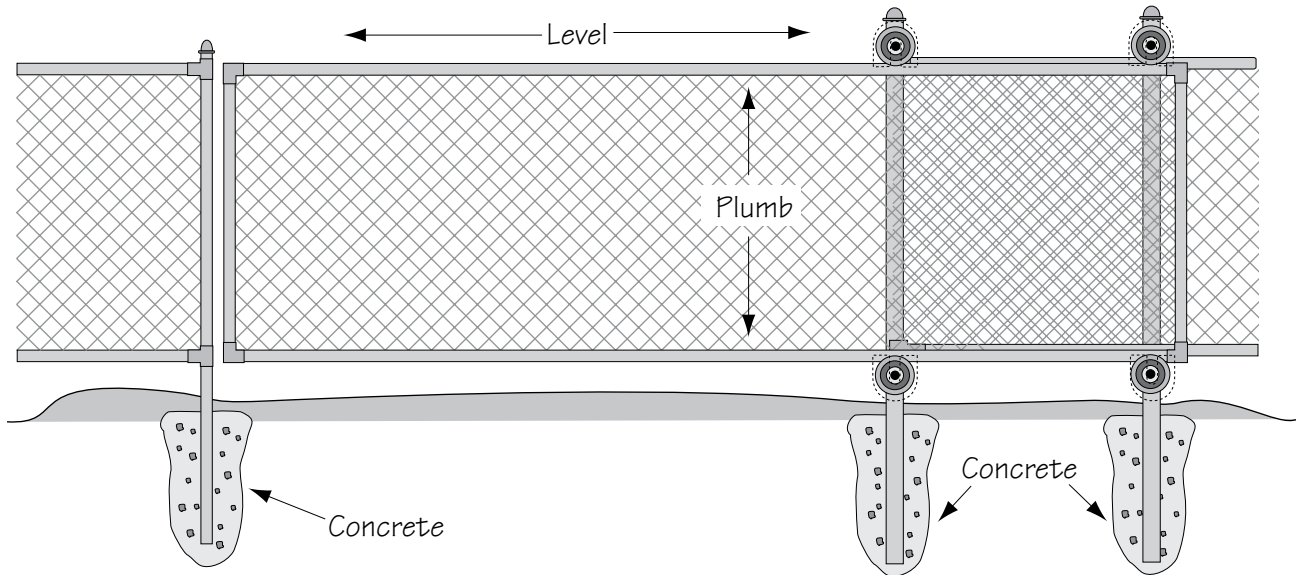

## Overview of Operator Installation

The diagram below shows a single slide gate installation with required safety features. The operator must be installed on the inside of the gate. Mighty Mule requires using safety edges and roller guards to help reduce the possibility of bodily injury.

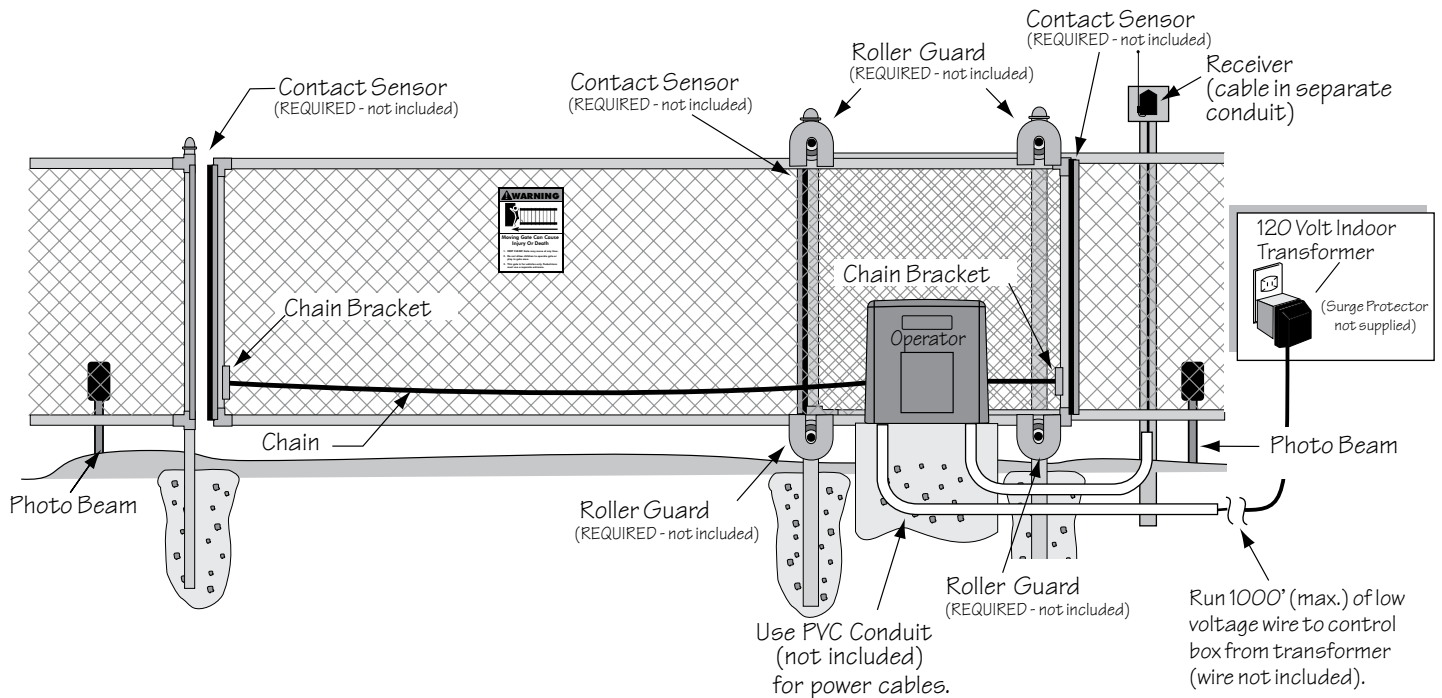

# DETERMINING MOUNTING OPTIONS

## Concrete Pad

Operator should be mounted securely on a level concrete pad. If you do not have an existing pad to work with, be sure to install wiring conduit before pouring concrete. You must use four  $\frac{3}{8}$ " diameter mounting anchors, washers and nuts (not included) to mount the operator to the pad.

Use mounting template provided (see page 9).

*Check local building codes for concrete pad depth below ground level.*

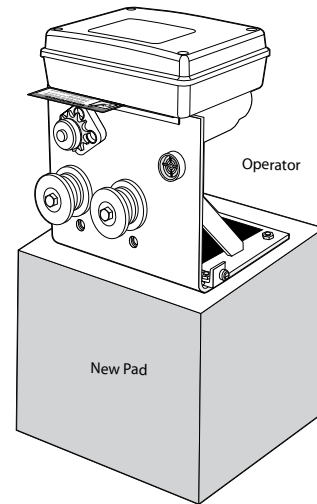

## Post Mount Adapter Plate (R4983)

*Not included, sold separately.*

30" galvanized post mount adapter. (See accessories on page 25).

*Check local building codes for concrete pad depth below ground level.*

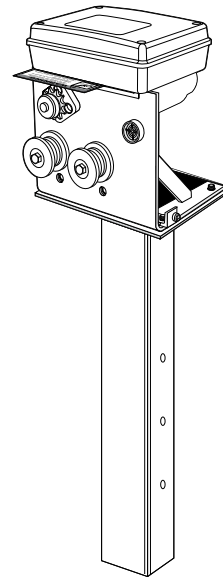

## Adjustable Pad Mount Adapter Plate (R4984)

*Not included, sold separately.*

Adjustable galvanized pad mount adapter mounts the MM-LPS13 to an existing concrete pad or other mounting surfaces (See accessories on page 25).

Pad Mount Adapter Plate can be adjusted from 6 inches to maximum height of 10 inches.

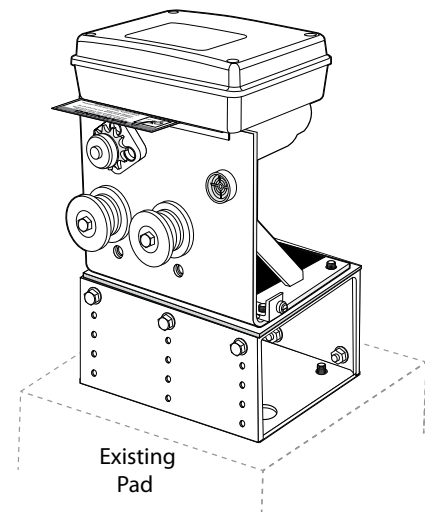

# DETERMINING OPERATOR MOUNT POSITION

## Step 1

Be sure the gate is properly installed and slides smoothly before installing the MM-LPS13 . The gate must be plumb, level, and move freely. The gate must not bind or drag on the ground. Never use a wheel on the gate, because the additional drag and resistance can cause the operator to obstruct.

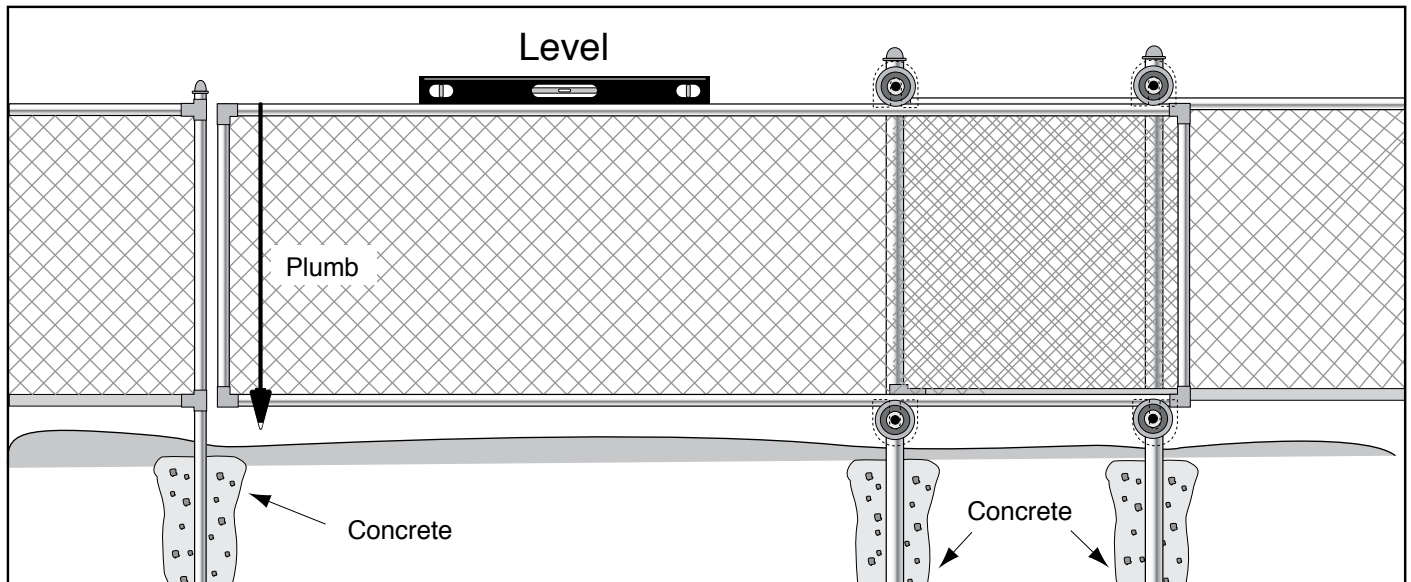

## Step 2

Install chain brackets at each end of the gate on the inside (operator side) of the gate. Hand tighten U bolts to allow for later adjustment (if necessary). Attach string to quick release pins and install quick release pins in the chain bracket slot farthest from the gate.

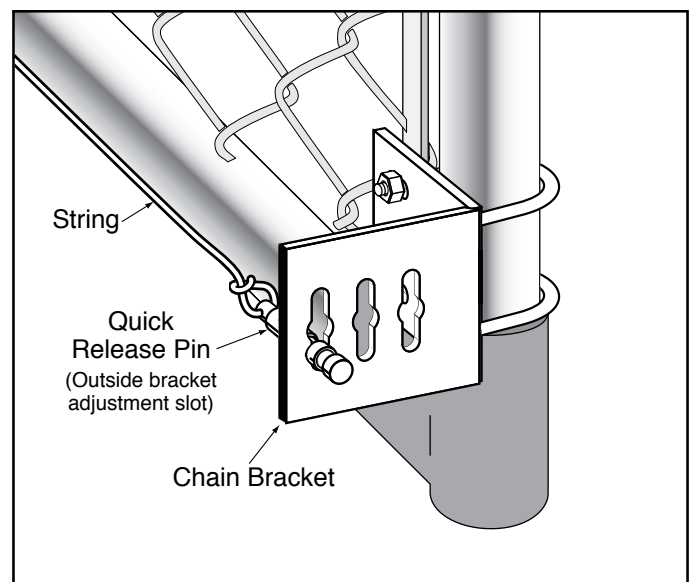
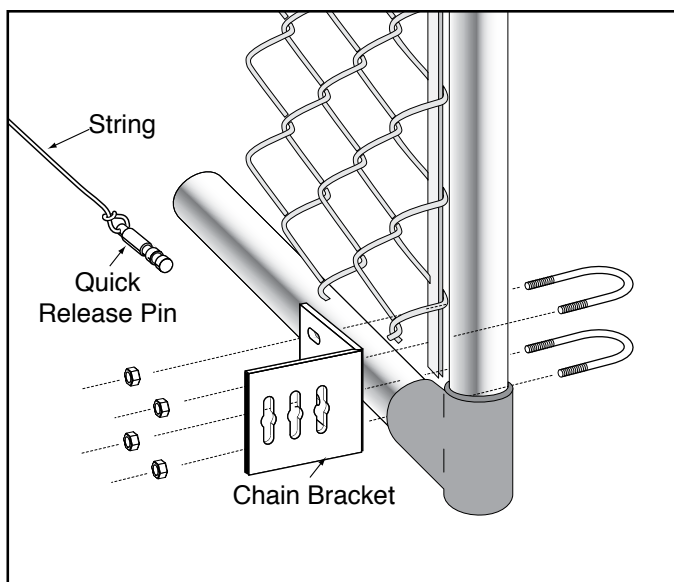

### Step 3

Adjust brackets as necessary until string is level and 7" minimum above the ground (see Illustration A).

(Use a string level as shown).

Tighten both brackets using wrench.

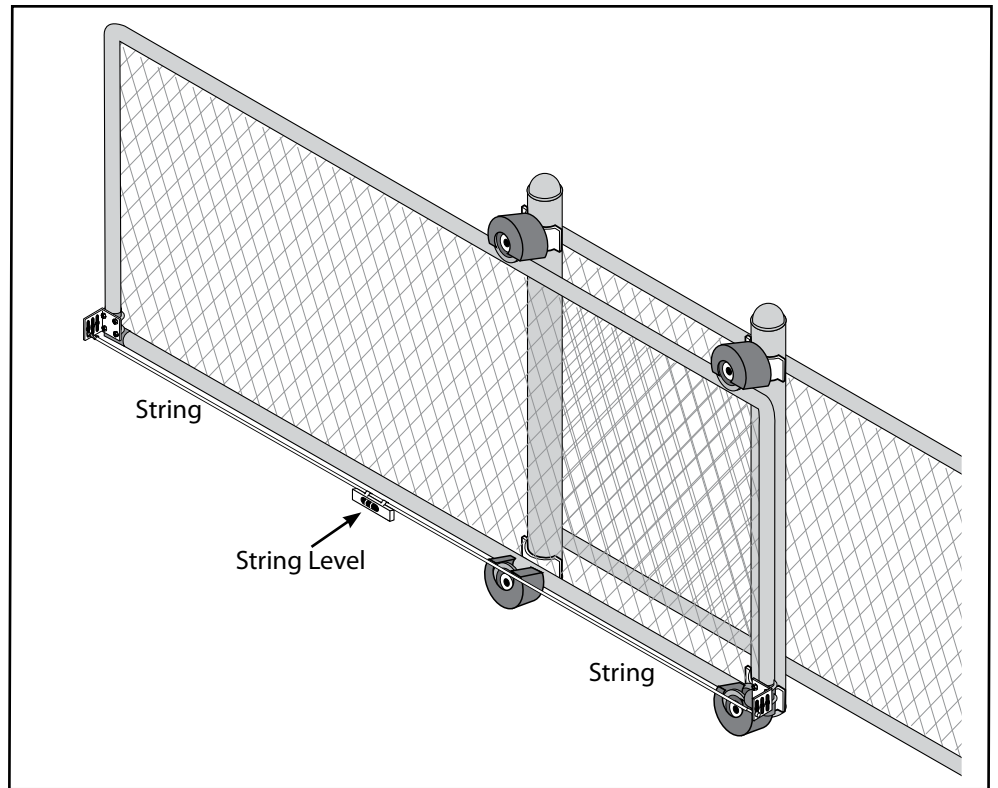

### Step 4

Find the center between the two roller/gate support posts. This should coincide with the position of the center point of the MM-LPS13 operator.

*Pad depth (minimum of 18" below ground) is dependent on soil conditions and local code (please check your local code).*

Illustrations A and B show where to locate the concrete pad in relation to the string and gate support posts. Be sure that you have a minimum of 7" from the string to the ground.

**It is crucial that the top of the concrete pad is level and exactly 3" below the string.**

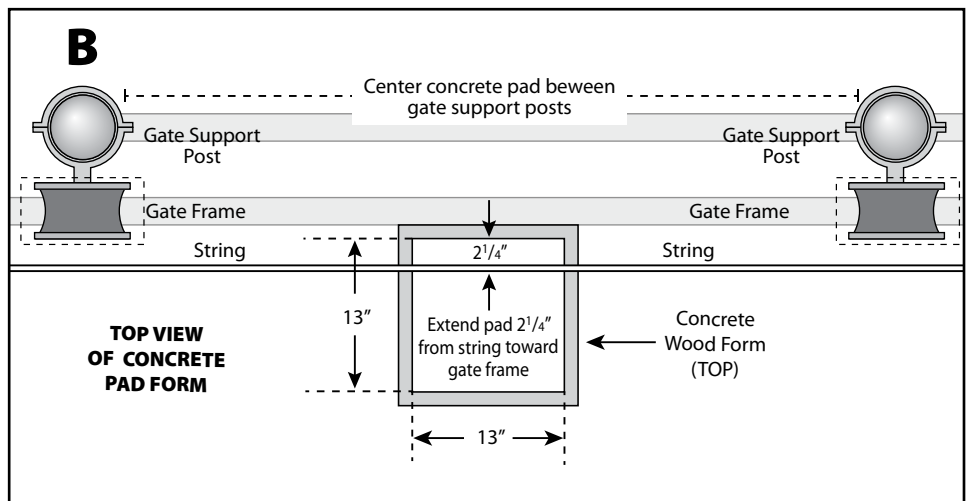
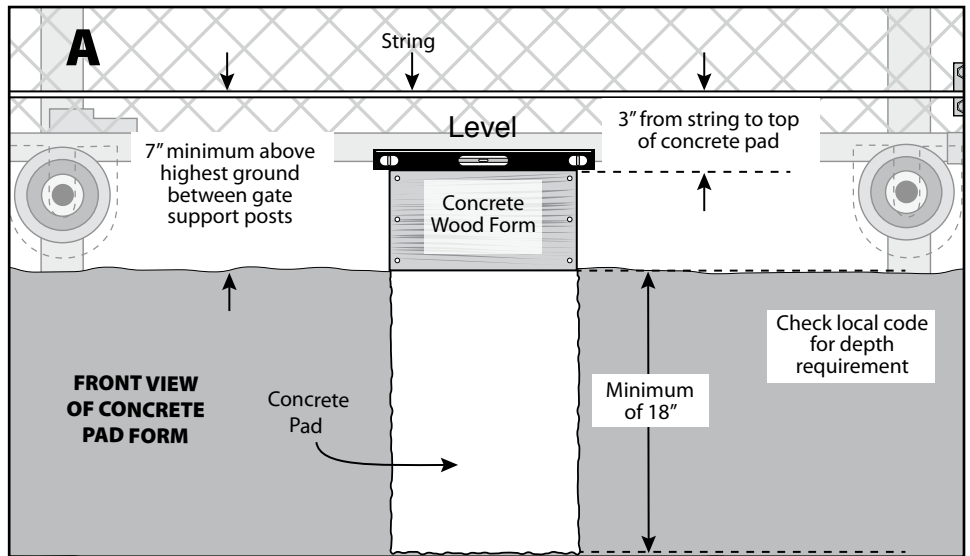

# USING THE MOUNTING TEMPLATE

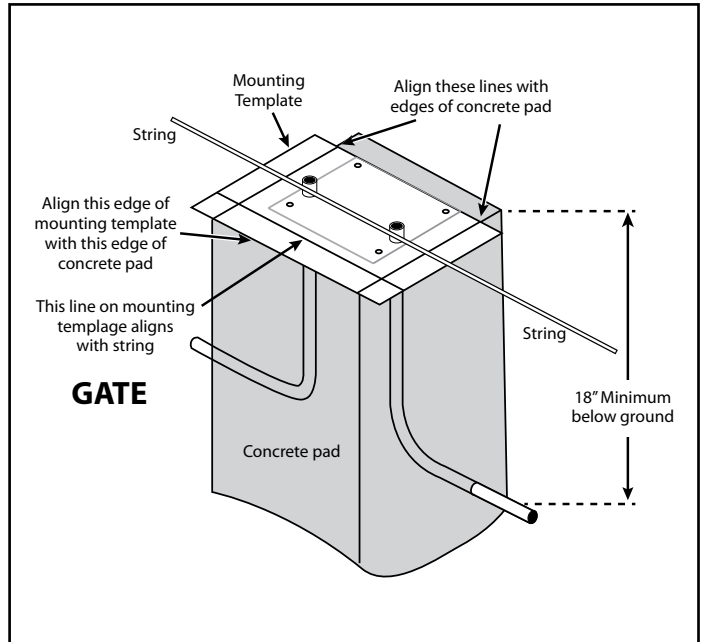
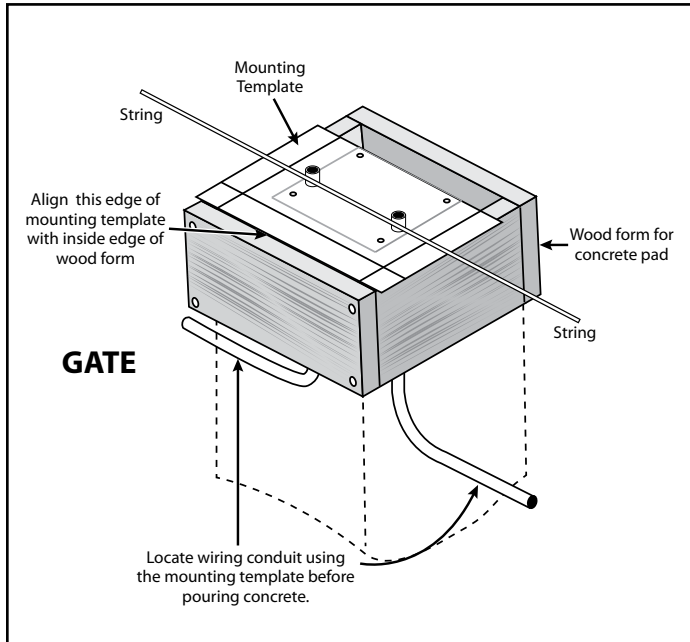

## Step 5

Align template on form as shown in illustration above. Position and secure wiring conduit. Remove template and pour concrete and let set.

## Step 6

After concrete has hardened, align template on concrete pad as shown above. Drill holes in concrete and install anchor bolts. Remove Template.

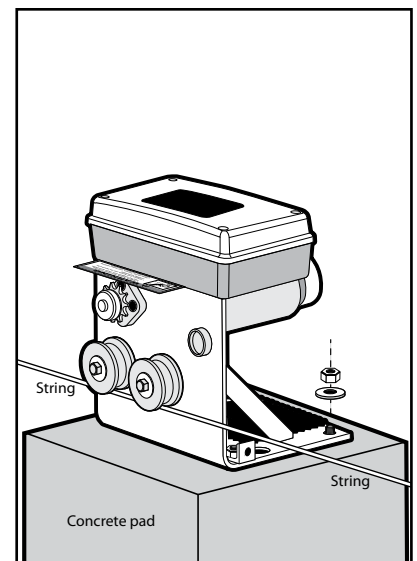
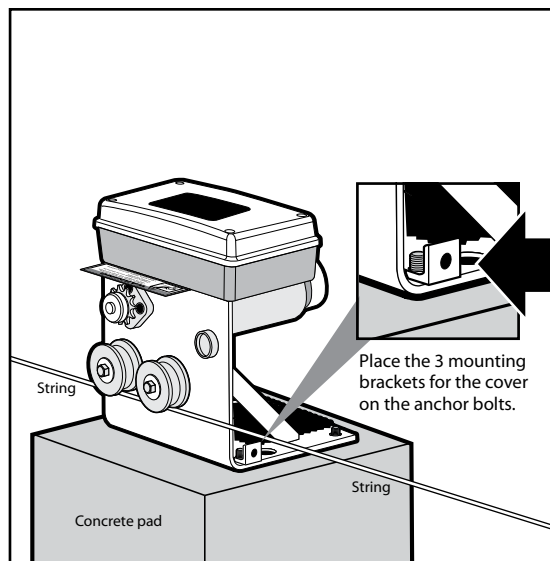
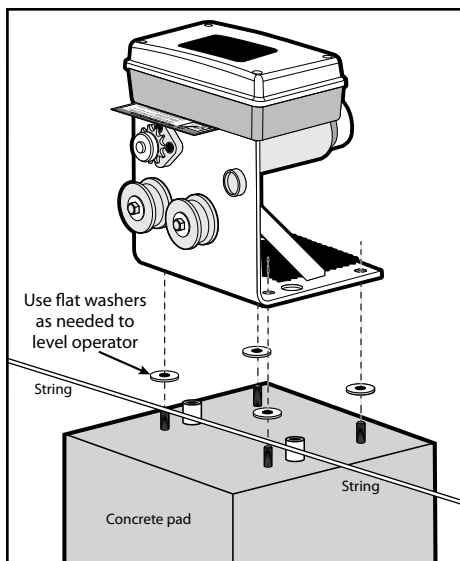

## Step 7

Align operator on anchor bolts. Check level.

Place the 3 mounting brackets for cover on anchor bolts, then assemble the washers and nuts.

Tighten with wrench.

# DETERMINING THE CHAIN LENGTH

Attach chain to the quick release pins and install pins in the chain bracket slot farthest from the gate.

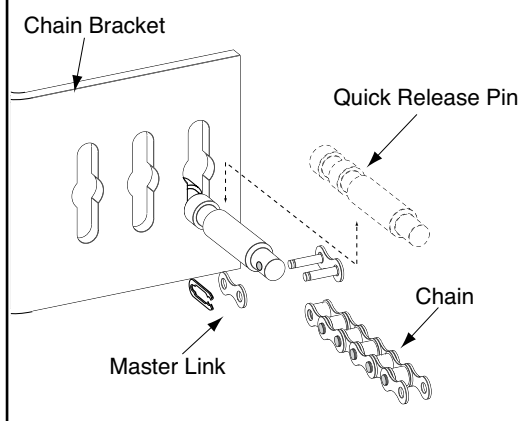

## Step 1

After opener is secured, remove the string from the quick release pins. Attach the chain to one quick release pin with a master link (see *Illustration*). Run the chain through the chain sprocket and idler wheels. (see *Illustration*).

## Step 2

Pull the chain to the second chain bracket. (see *Illustration*). Adjust chain to allow 1 inch of slack for every 10 ft. of chain (See *Illustration below*). Mark the chain where it meets the second quick release pin.

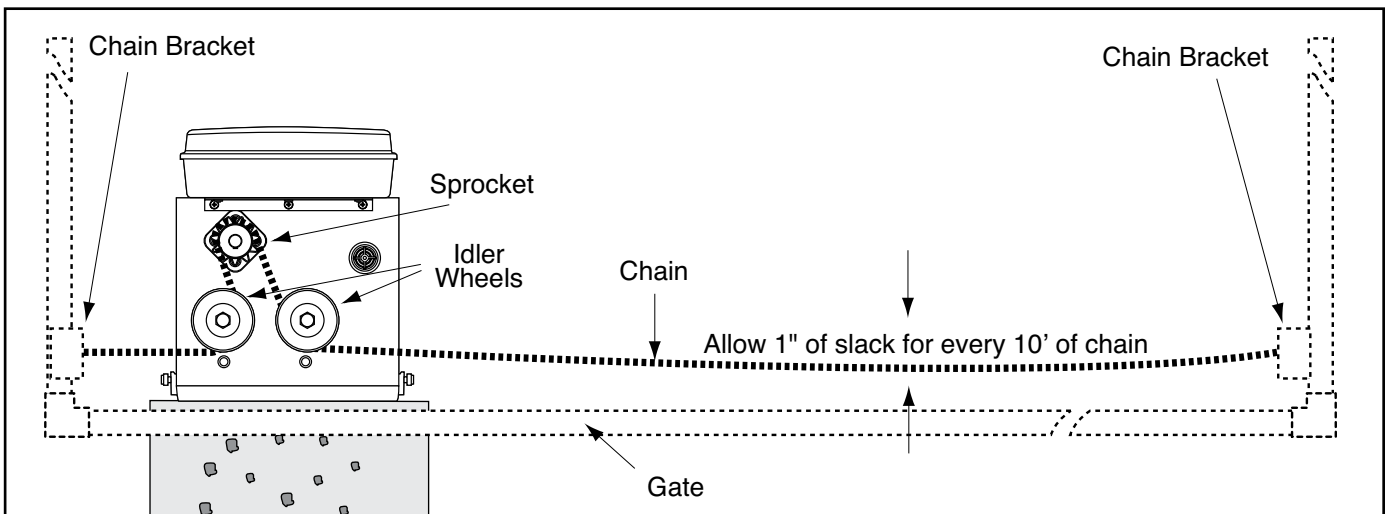

## Step 3

Shorten chain by driving the pin out of the chain link using a tool such as a punch or chain break. Connect the chain to the second quick release pin using a master link.

## Step 4

After proper chain length has been determined, remove the assembled chain and quick release pins from both the chain brackets, the operator idler wheels and sprocket before you proceed.

**NOTE: The operator should be free of the chain at this point in the installation process.**

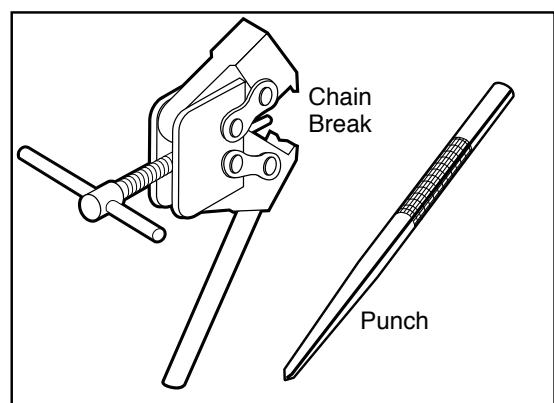

# POWERING THE SYSTEM

## Connecting the Battery

### Step 1

Make sure the control box power switch is in the **OFF** position.

Slide battery into position with its terminals to the left.

Connect the **black** battery lead to the **negative** (-) terminal, and the **red** battery lead to the **positive** (+) terminal.

## Installation of the Mighty Mule Transformer

Go to page 12 if using solar panel

Choose the electrical outlet which the transformer will be plugged. Measure the distance from the electrical outlet to the control box, following the path where the low voltage wire will run **using no more than 1000 ft.**

### Step 2

Unscrew and remove the top cover of the control box.

Run low voltage wire from the electrical outlet (where the transformer will be plugged in) to the operator control box.

Feed the low voltage wires through the strain relief on the front of the control box.

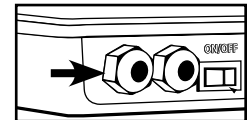

Pull approximately 3 in. of low voltage wire into the control box to accommodate terminal connections. To maintain adequate charging power, use 16 gauge dual conductor, stranded, direct burial wire (see *Accessories on page 24*).

**NOTE:** Wires coming from the ground to the control box should be run through PVC conduit to protect them from damage.

### Step 3

Strip  $\frac{3}{16}$ " off the ends of the low voltage wire and twist tightly. These wire ends will be attached to the control board at the **18VAC** terminals located on the **POWER IN** terminal block (see *Illustration at right*).

Wire sheathing should not come in contact with terminals, however, it should not be stripped so far that wires can come in contact with one another.

Insert one transformer wire into an **18VAC** terminal. Insert the other transformer wire into the remaining **18VAC** terminal (see *illustration*). Transformer wires can be connected to the **18VAC** terminals regardless of color.

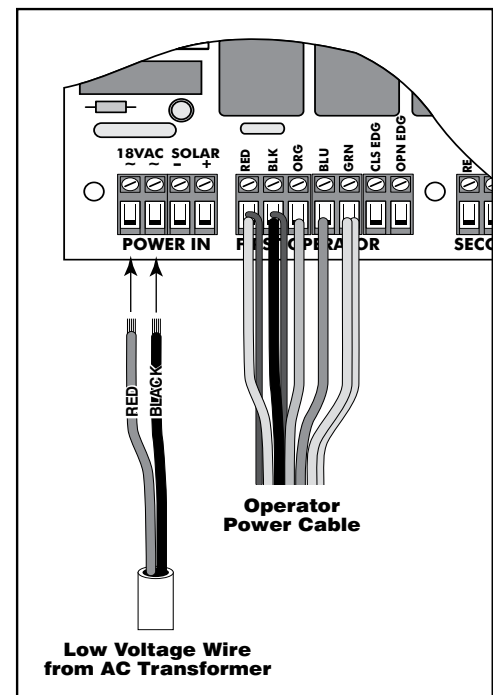
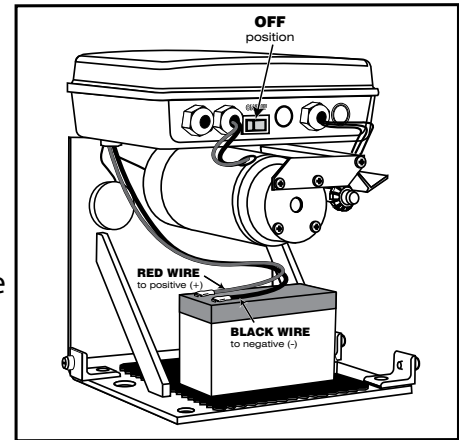
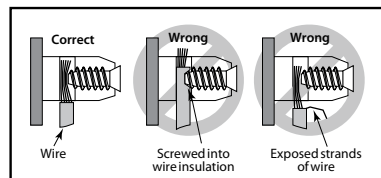

## Step 4

Strip the ends of the low voltage wire and attach ends to the transformer terminals.

**To prevent damage to transformer, make sure the exposed wire ends do not touch each other!**

## Step 5

Plug the transformer into a weatherproof electrical outlet.

**NOTE:** Use of a surge protector is strongly recommended.

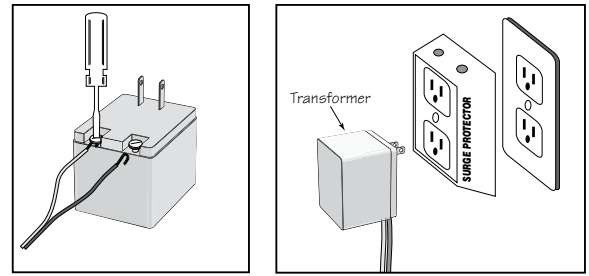

## Connecting Solar Panel(s) (Only if transformer is not used)

**NOTE: NEVER USE THE SOLAR PANEL AND THE AC TRANSFORMER AT THE SAME TIME! It will damage the control board.**

Feed the solar panel wires into the control box and attach them to the appropriate terminals on the control board (see illustration). The **RED** solar panel wire goes to the (+) **POSITIVE** solar terminal and the **BLACK** solar panel wire goes to the (-) **NEGATIVE** solar terminal.

Tighten set screws against exposed end of wires.

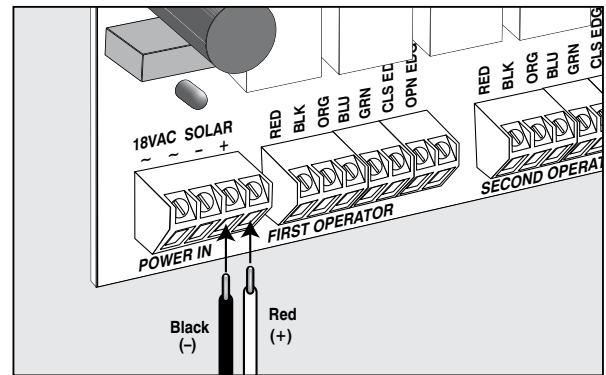

## Step 6

### Connecting The Receiver

Temporarily run the receiver to the outside of the fence, clear of the moving path of the gate at this time (Permanent mounting instructions on page 17).

Feed the receiver wires into the control box and attach them to the appropriate terminals on the control board (see illustration).

Tighten set screws against exposed end of wires.

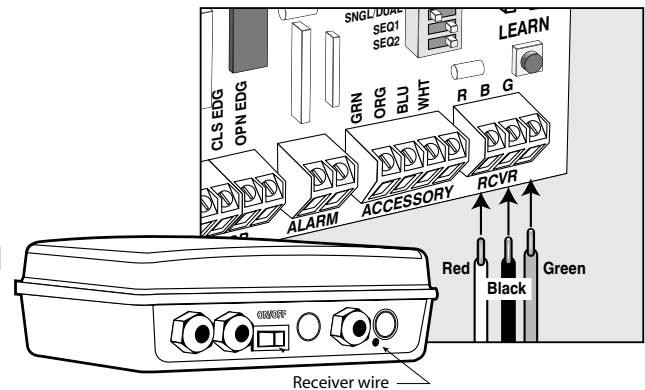

## DIP SWITCH CONTROL BOARD SETTINGS



**BEFORE Changing the DIP Switch, make sure that the control box power switch is OFF.**

The DIP Switches determine the opening direction of the gate opener (either right to left, or left to right).

If your gate opens from **Right to Left** (from the operator side of the gate). DIP Switch 4 is set to **"Pull."**

If your gate opens from **Left to Right** (from the operator side of the gate), you will need to adjust DIP Switch 4 to **"Push."**

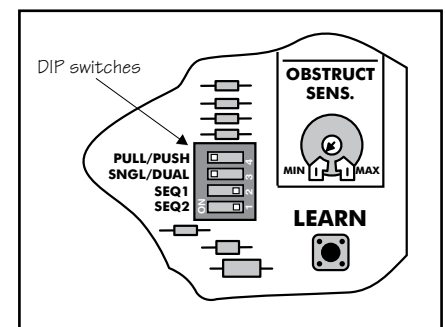

# DETERMINING THE GATE'S OPEN POSITION

## Gate Opens Right to Left

Facing the gate (on same side as operator), the gate opens to the **left**, place or leave the **PULL/PUSH** DIP switch in the "**PULL**" position.

**⚠ Verify that the chain is completely removed from operator and both chain brackets at this time.**

- Step 1** — Turn the control box power switch to the **ON** position.
- Step 2** — Install a jumper wire. Wire one end of the jumper wire to the accessory terminal marked **GRN**. Touch the other end of wire to the **BLU** accessory terminal (see *Illustration*).
- Step 3** — Operator motor will run then **STOP**.
- Step 4** — Turn the control box power switch to the **OFF** position.
- Step 5** — Remove jumper wire, charging source wires and disconnect battery.
- Step 6** — Manually slide the gate to the open position approximately 2-3" from the fully open position.
- Step 7** — Re-install the chain on the chain brackets and the operator. **This is the gate's OPEN position.**
- Step 8** — Connect the battery and charging source and turn the operator to the **ON** position.
- Step 9** — Press transmitter to close gate. The gate will move toward the closed position and stop. You will need to adjust the closed position for your gate application at this time. **Proceed to Adjusting the Limit Switch on page 14.**

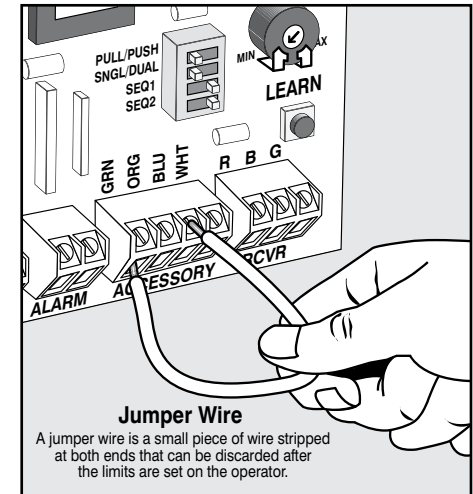
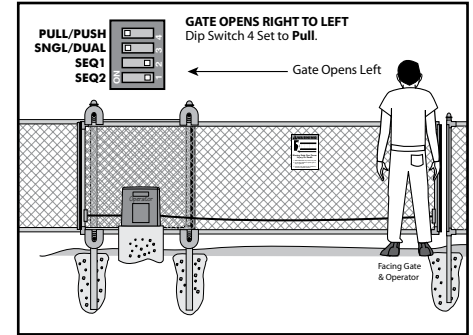

## Gate Opens Left to Right

Facing the gate (on same side as operator) the gate opens to the **Right**, place the **PULL/PUSH** DIP switch in the "**PUSH**" position.

**⚠ Verify that the chain is completely removed from operator and both chain brackets at this time.**

- Step 1** — Turn the control box power switch to the **ON** position.
- Step 2** — Install a jumper wire. Wire one end of the jumper wire to the accessory terminal marked **GRN**. Touch the other end of wire to the **BLU** accessory terminal (see *Illustration*).
- Step 3** — Operator motor will run then **STOP**.
- Step 4** — Turn the control box power switch to the **OFF** position.
- Step 5** — Remove jumper wire, charging source wires and disconnect battery.
- Step 6** — Manually slide the gate to the open position approximately 2-3" from the fully open position.
- Step 7** — Re-install the chain on the chain brackets and the operator. **This is the gate's OPEN position.**
- Step 8** — Connect the battery and charging source and turn the operator to the **ON** position.
- Step 9** — Press transmitter to close gate. The gate will move toward the closed position and stop. You will need to adjust the closed position for your gate application at this time. **Proceed to Adjusting the Limit Switch on page 14.**

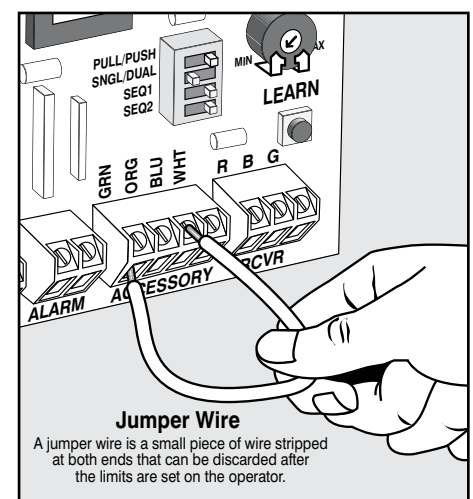
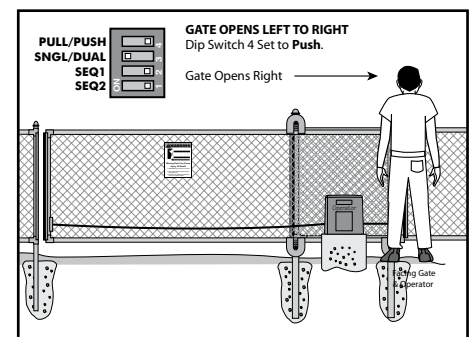

**NOTE: If gate does not move, adjust the INERTIA and OBSTRUCT SENS. settings located on page 15.**

# ADJUSTING THE LIMIT SWITCHES

The limit switches determine how far the gate travels to open and to close.

**⚠ BEFORE Adjusting the limit switches, make sure that the control box power switch is OFF.**

Adjust the limit switches using the limit nuts. Lift limit switch plate to adjust limit nuts (see *Illustration*).

The open and closed position switches will be reversed depending on whether the gate opens from **Right to Left** or from **Left to Right**.

**⚠ WARNING! USE EXTREME CAUTION when adjusting limit switches to prevent fingers, hair, clothing, etc., from getting caught under the limit switch plate and possibly causing bodily injury.**

**Gate opens from Right to Left:** ←

**Note: Small or slight adjustments to the Limit Nuts are recommended.**

**STEP 1 – Closed Position:** For gate to close further, turn Limit Nut B clockwise. For gate to close less, turn Limit Nut B counter clockwise.

**STEP 2 – Open Position:** Fine tune the open position as needed. For gate to open further, turn Limit Nut A counter clockwise. For gate to open less, turn Limit Nut A clockwise.

**Gate opens from Left to Right:** →

**STEP 1 – Closed Position:** For gate to close further, turn Limit Nut A counter clockwise. For gate to close less, turn Limit Nut A clockwise.

**STEP 2 – Open Position:** Fine tune the open position as needed. For gate to open further, turn Limit Nut B clockwise. For gate to open less, turn Limit Nut B counter clockwise.

**Turn the control box power switch ON.** Test limit switch adjustments. Adjust settings as needed until the desired limits are set.

**NOTE - Turn operator power switch to the OFF position before adjusting the limit switches.**

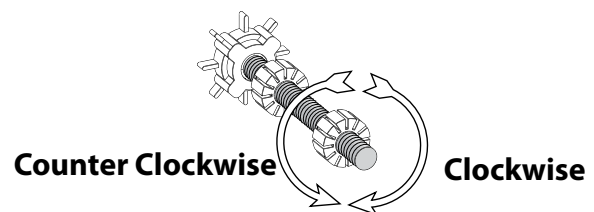
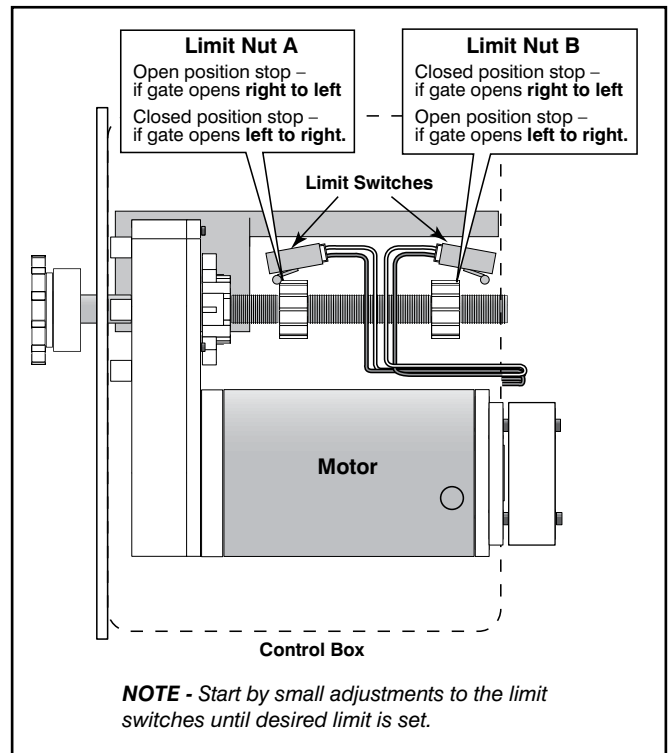
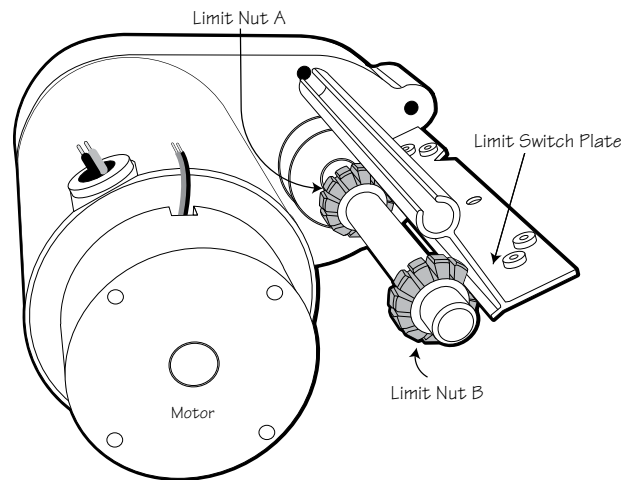

# ADJUSTING THE POTENTIOMETERS

## ⚠ WARNING! ⚠

All three potentiometers were set to minimum at the factory. The **OBSTRUCT SENS.** potentiometer **MUST** be adjusted above the factory setting for your MM-LPS13 operator to function properly. If the potentiometer is left at **MIN**, your gate operator may “obstruct” (i.e., stop and reverse) as soon as it is activated.

**BE SURE TO PROPERLY RETEST THE GATE OPERATOR AFTER MAKING ANY ADJUSTMENTS; FAILURE TO DO SO MAY RESULT IN SERIOUS INJURY OR DEATH.**

## Potentiometers

The three (3) potentiometers on the control board operate like a volume control on a radio. They control the auto close timer, inertia, and obstruction sensitivity of the operator. Use a small slotted screwdriver to turn the arrow in the center of the potentiometer. Clockwise rotation increases the setting (**MAX**). Counterclockwise rotation decreases the setting (**MIN**).

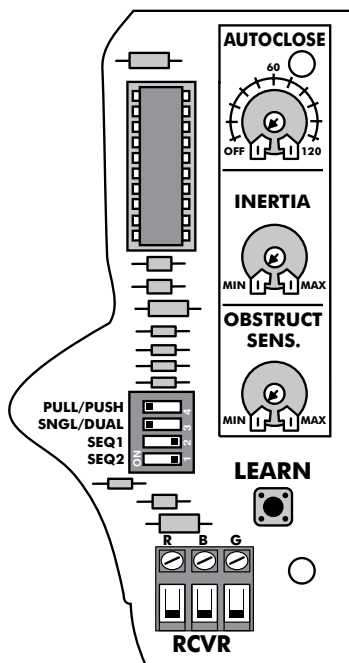

**AUTO CLOSE** (auto close timer): Determines how long the gate will remain open before it automatically closes. The limits are **OFF**, or from 3 to 120 seconds. The factory setting is **OFF**.

**INERTIA**: Fine tunes obstruction sensitivity in the opening and closing modes. **INERTIA** allows the operator to attempt to push an obstruction clear of the gate path. When **INERTIA** is set to **MIN** the operator will obstruct *quickly* (i.e., will attempt to push an obstruction briefly); when set to **MAX** the operator will obstruct *slowly* (i.e., will push against an object for a longer period). The factory setting is **MIN**.

**OBSTRUCT SENS.** (obstruction sensitivity): Determines the amount of *force exerted by the gate* on an obstruction before the operator stops and reverses. The gate will exert *minimum force* before obstructing when set to **MIN**. When set to **MAX**, the operator will exert *maximum gate force* before obstructing (i.e., the operator will require greater resistance before stopping and reversing). The factory setting is **MIN**.

**ALWAYS KEEP SAFETY AT THE TOP OF YOUR LIST WHEN ADJUSTING OR SERVICING YOUR AUTOMATIC GATE OPERATOR!**

# PROGRAMMING YOUR PERSONAL TRANSMITTER

## Program Your Personal Transmitter Setting

All transmitters are set to a standard code at the factory and are ready to operate your Mighty Mule gate operator. For your safety and security, **we strongly recommend** that you replace the factory setting with your own personal setting. Follow the directions below:

NOTE: If you have multiple transmitters, you should adjust all of them at this time.

### Step 1

Use a small phillips head screw driver to remove the transmitter cover.

### Step 2

Set the transmitter DIP switches using a small screwdriver. There are nine (9) switches; each can be placed in three different positions (+, 0, -). **DO NOT** set all the switches in the same position, such as all +, all 0, or all -. Once the DIP switches have been reset, replace and close the access cover.

WARNING: No other adjustments should be made inside the transmitter.

### Step 3

- Make sure the control box power switch is **OFF**.
- Unscrew and remove the control box cover.
- Press and hold the **LEARN** button on the control board, and turn the power switch **ON**. Release **LEARN** button. Wait 15 seconds for the receiver to charge.
- Press and hold transmitter button until the red **STATUS** LED comes **ON**.
- Release transmitter button. The new switch setting is stored in the control board memory.
- Replace the cover.

### Step 4

**AT THIS POINT YOU SHOULD TEST RECEIVER RANGE BEFORE PERMANENTLY INSTALLING IT.**



The Troubleshooting Wizard has detailed information about this and other Installations.

**24/7 Troubleshooting Wizard:**  
<http://support.gtoinc.com>

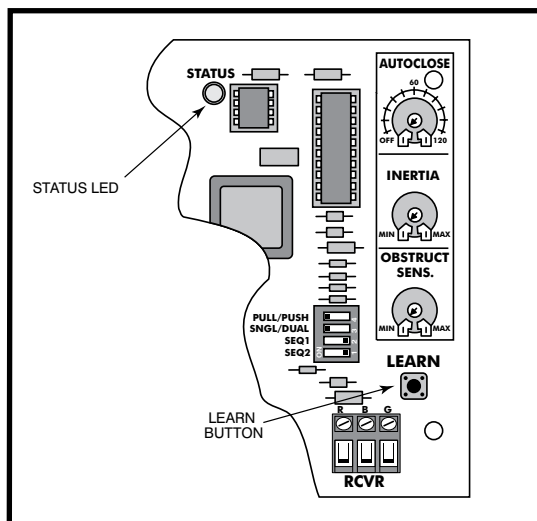
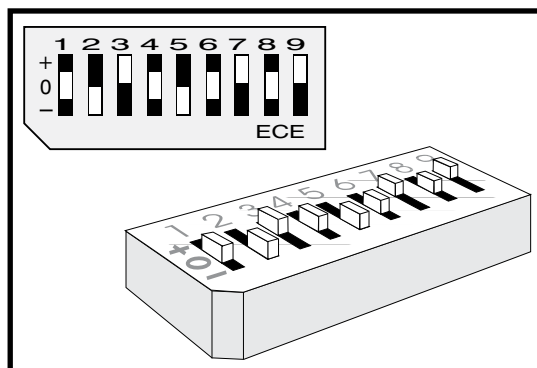
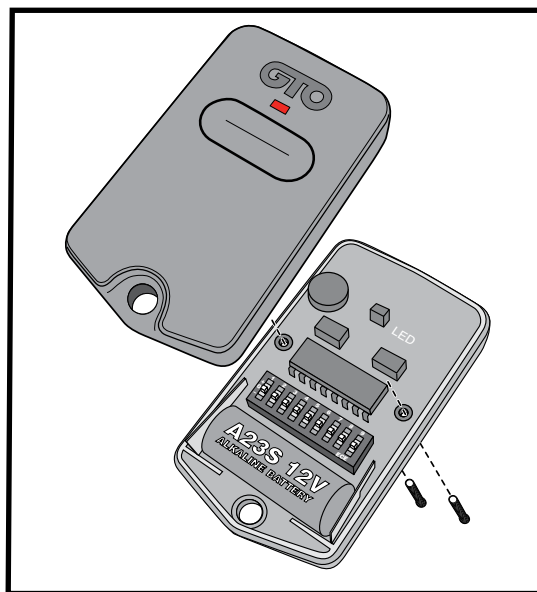

# MOUNTING THE RECEIVER

## Receiver Installation

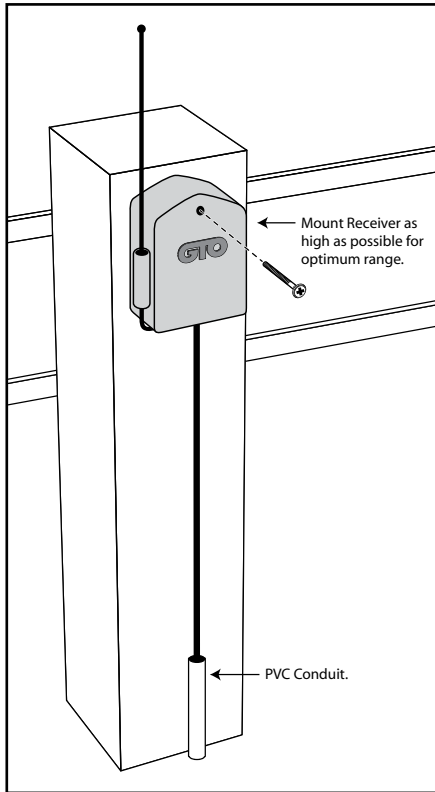

Check the range of the receiver *before permanently mounting* it. You may have to try different locations before permanently mounting the receiver. The receiver range can vary from 50 to 100 feet depending upon weather, topography, and external interference.

### Mount the receiver:

- Ensuring a line-of-sight between transmitter and antenna.
- At least 3 feet away from AC voltage.
- As high as possible for optimum range.
- DO NOT mount receiver upside down.

### The receiver cable:

- NEVER splice receiver cable!
- Run the receiver cable through PVC conduit to protect it from damage.
- DO NOT run cable in conduit containing AC wiring.

***Install the receiver on the outside of the fence, clear of the moving path of the gate.***

**This device complies with FCC rules Part 15. Operation is subject to the following conditions:**

1. This device may not cause harmful interference.
2. This device must accept an interference that may cause undesired operation.

Transmitter distance may vary due to circumstances beyond our control.

**NOTE:** The manufacturer is not responsible for any radio or TV interference caused by unauthorized modifications to this equipment. Such modifications could void the user's authority to operate the equipment.

# CONNECTING SAFETY DEVICES

The MM-LPS13 series operators are equipped with built-in obstruction detection. These operators are designed to stop and reverse the gate for 2 seconds when it comes in contact with an obstruction. **Safety edges or photo beams MUST be installed on the gate.**

**Refer to the sensor manufacturer's instructions for information about installing these devices on a vehicular gate.**

**⚠ Make sure the control box power switch is OFF before connecting safety device wiring to the terminal blocks.**

Insert the safety device wires into the **CLS EDG** terminal (located on the terminal block) for the gate closing mode. Connect the **COMMON** wire on the safety devices to the **GRN** terminal. Connect the safety device wires for the gate opening mode to the **OPN EDG** terminal in the same manner.

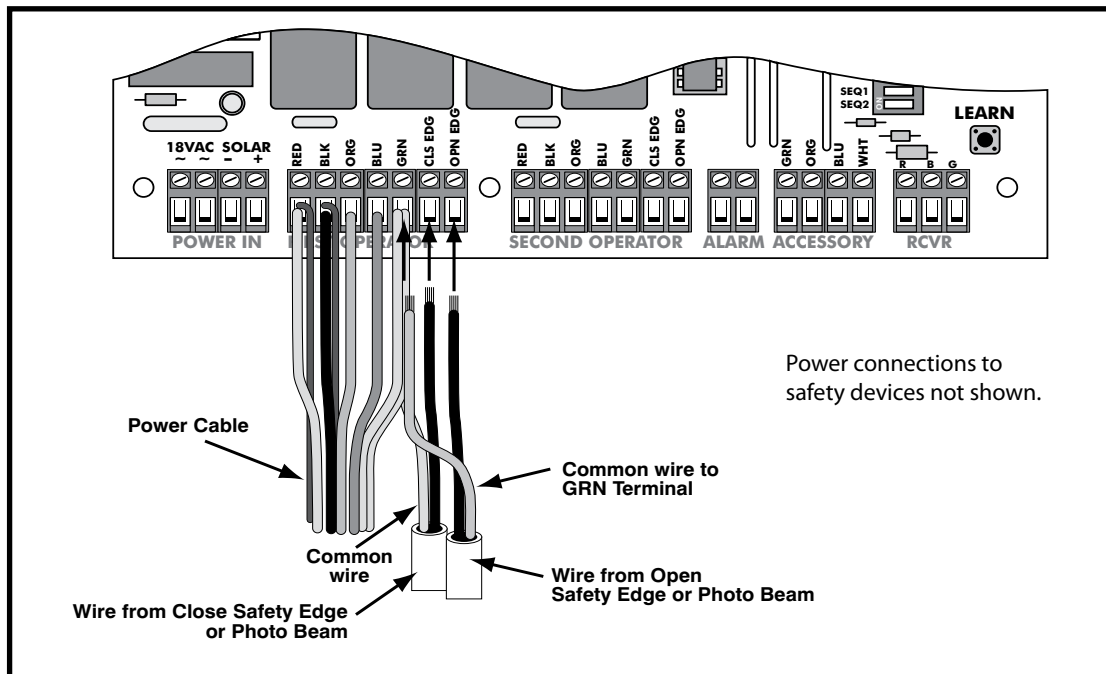

# INPUT CONNECTIONS

All inputs are dry-contact, normally open.

## ① **CLS EDGE:** (Can be used with edge sensor device or photo beam)

- Activation of this input while the gate is closing will cause the gate to stop and reverse direction for approximately 2 seconds. The autoclose will reset if the unit has returned to the full open position.
- Activation of this input while gate is opening has no effect (gate will continue to open). *Autoclose will reset (if enabled).*
- Activation of this input while gate is idle will prevent gate from closing.

## ② **OPN EDGE:** (Can be used with edge sensor device or photo beam)

- Activation of this input while the gate is opening will cause the gate to stop and reverse direction for approximately 2 seconds.
- Activation of this input while gate is closing has no effect (gate will continue to close).
- Activation of this input while gate is idle will prevent gate from opening.

## ③ **ORG:** (Typically used with photo beam devices, loop detectors or other non-contact sensors)

- Activation of this input while the gate is closing will cause the gate to stop and return to the open position
- Activation of this input while gate is opening has no effect (gate will continue to open). *Autoclose will reset (if enabled).*
- Activation of this input while gate is idle will prevent gate from closing.

## ④ **BLU:** (Typically for use with exit loop or wand)

- Activation of this input will open the gate if it's not already at the open position.
- Activation of this input while gate is at the open limit will restart the auto close time (if enabled).

## ⑤ **WHT:** (Typically used with push button or hard wired key pad)

- Each activation at this input will cycle the operation as follows ... X Open X STOP X CLOSE X STOP X OPEN X ...

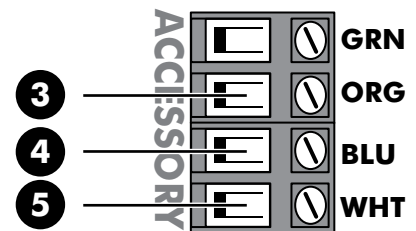
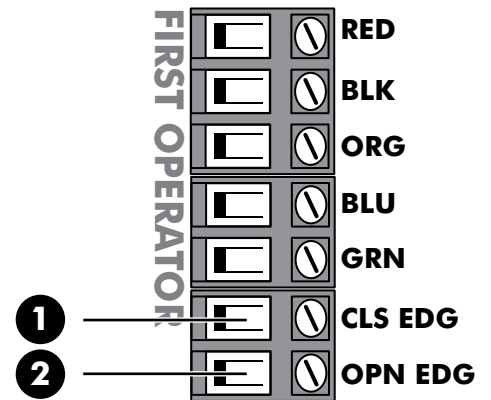

# CONNECTING ACCESSORIES

Make sure the control box power switch is OFF before connecting accessories.

The **ACCESSORY** terminal block is the connection point for accessories such as push buttons, safety loops, intercoms, etc. The **ACCESSORY** terminal marked **GRN** is the common ground for all accessories. **GRN** is paired with the terminals shown below when connecting accessories to the control board.

**IMPORTANT:** Make sure to twist exposed wires tightly and insert them into the terminals without loose strands. Tighten set screws against exposed end of wires.

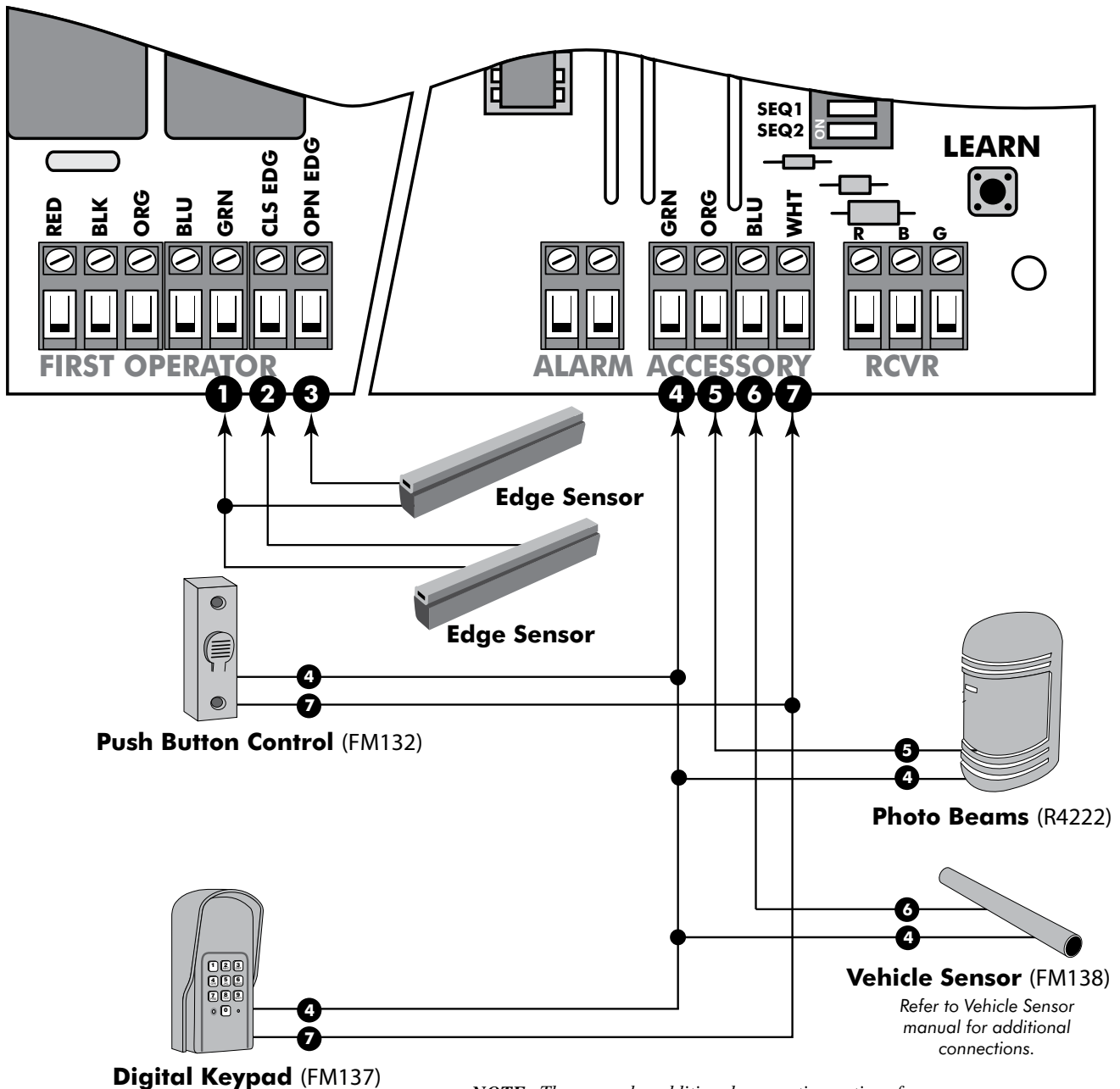

# ATTACHING THE HOUSING

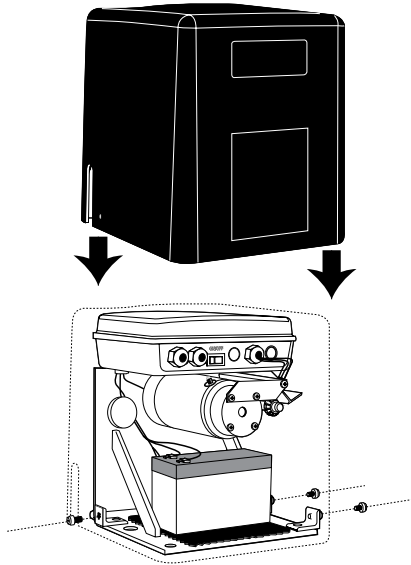

Mount the operator housing after all installation procedures are complete. Slide operator housing over legs, align holes, and use screws provided to attach housing to operator.

**IMPORTANT:** Hang the two (2) Warning Signs (provided) on both sides of the gate before operating. **Make sure** all warning signs and labels are in place.

# WARRANTY AND REPAIR SERVICE

If your MM-LPS13 Gate Operator is not operating properly, please follow the steps below:

1. First use the procedures found in the Troubleshooting Guide (see page 22).
2. Use the 24/7 Troubleshooting Wizard at <http://support.gtoinc.com>.
3. If you are unable to solve the problem, call the GTO Service Department at (800) 543-1236, or (850) 575-4144. Refer to the serial number (located on the right side of the control box) and date of purchase when calling for assistance.
4. If repair or replacement of your gate operator is necessary, the Service Department will assign a Return Goods Authorization (RGA) number to you.
5. Once you have received your RGA# you are required to send in your original equipment for repair. Please refer to Manufacturers' Limited Warranty for complete details. Securely pack the component(s) authorized for return to the factory. Include a copy of your sales receipt for the purchase of the product(s). Write the RGA number issued to you on the outside of the package in **LARGE BOLD PRINT**.

Ship the package(s) freight prepaid to: GTO, 3121 Hartsfield Road, Tallahassee, Florida, USA 32303.

**NOTE: Products returned to GTO without a Return Goods Authorization (RGA) number in LARGE BOLD PRINT on the outside of the package WILL NOT be accepted. Also, items returned to GTO freight collect WILL NOT be accepted.**

## GTO Technical Service

8:00am–7:00pm (EST) • Monday–Friday

**3121 Hartsfield Road • Tallahassee, Florida, USA 32303**  
**1-800-543-1236 or (850) 575-0176 • Fax (850) 575-8912**

**Web site [www.mightymule.com](http://www.mightymule.com)**

**24/7 Troubleshooting Wizard: <http://support.gtoinc.com>**

# TROUBLESHOOTING GUIDE



If your gate opener does not function properly, use this guide or use the online troubleshooter at <http://support.gtoinc.com> before calling the GTO Service Department.

SYMPTOMS	CAUSES	CORRECTIVE ACTION
Unit clicks but does not operate	<ul style="list-style-type: none"> <li>• Gate binding or not sliding freely</li> <li>• Motor pulling too many amps</li> <li>• Motor open circuit</li> </ul>	<ul style="list-style-type: none"> <li>• Check replace fuse(s)</li> <li>• Check battery connections at battery and control board</li> <li>• Check motor lead connection at the control board</li> <li>• If this is single gate operator, make sure that DIP 3 is set for single. Turn unit off them back on.</li> <li>• Check battery for dead cell (load test)</li> </ul>
Unit not responding (Red status LED flashing)  Unit works (Green status LED off)	<ul style="list-style-type: none"> <li>• Low battery (less than 12 vdc)</li> <li>• Unit not charging (see voltage chart)</li> <li>• Adverse solar conditions</li> </ul>	<ul style="list-style-type: none"> <li>• Test transformer output</li> <li>• Test solar panels</li> <li>• Check battery for dead cell (load test)</li> </ul>
Unit not responding (Red status LED on)	<ul style="list-style-type: none"> <li>• Transmitter not programmed correctly</li> <li>• Faulty accessory device</li> </ul>	<ul style="list-style-type: none"> <li>• Reprogram your transmitter</li> <li>• Remove accessories. If unit functions - you likely have a accessory issue</li> <li>• Momentarily connect the WHT &amp; GRN on accessory terminal block. If unit functions, then you may have a faulty receiver, receiver circuit or remote transmitter</li> </ul>
Unit not responding (Status LED off)	<ul style="list-style-type: none"> <li>• Unit may not be charging</li> </ul>	<ul style="list-style-type: none"> <li>• Cycle power switch</li> <li>• Check battery voltage</li> <li>• Check receiver wiring</li> <li>• Check transformer and wiring</li> <li>• Check solar panel and/or solar conditions</li> <li>• Check battery for dead cell (load test)</li> </ul>
Unit stopping and reversing direction during operation	<ul style="list-style-type: none"> <li>• Improper obstruction setting</li> </ul>	<ul style="list-style-type: none"> <li>• Adjust gate. The gate is binding or not sliding freely</li> <li>• Adjust the obstruction and the inertia POT as needed. (see installation manual for instruction)</li> <li>• Check and/or remove accessory and test for proper operation</li> </ul>

**NOTE: Voltage readings are on page 23.**

# MAINTENANCE



**WARNING: ALWAYS TURN OPERATOR OFF AND DISCONNECT AC POWER BEFORE ADJUSTING OR SERVICING IT!**



## Routine Maintenance:

- Test the operator, accessories, and safety devices monthly.
- Service the gate operator, accessories, and safety devices regularly.

## Maintenance Checklist

- Test the safety devices to make sure the gate responds.
- Check the obstruction settings (both open and close modes) see page 15.
- Lubricate and adjust the chain when necessary.
- Check for wear on all moving parts, and tighten bolts as necessary.
- Check rollers on the gate and lubricate if needed.
- Check for loose or corroded wires.
- Make sure the warning signs, roller guards, fence screen, etc. (see page vi) are installed.

## VOLTAGE READINGS

18 Vac Transformer	18.0 to 22.0 Vac
10 W Solar panel (single)	18.0 to 22.0 Vdc
<i>In FULL SUN — measure voltage with the Solar Panel Disconnected.</i>	
12 V, 7 amp hour Battery	12.5 to 13.5 Vdc
<i>Measure voltage at battery terminals with battery disconnected</i>	
Charging circuit	12.0 to 14.8 Vdc
<i>Measure voltage at battery terminals with battery connected</i>	

# ACCESSORIES

## Accessories are Available From Your Retail Store

### POWERING ACCESSORIES



#### Low Voltage Wire [RB509]

The 16 gauge, stranded, dual conductor low voltage Wire is for connecting the AC powered transformer, solar panel or wired accessories to the system's control board. This specially designed wire is UV treated, PVC coated, and ready for direct burial.

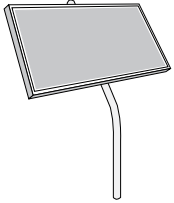

#### Solar Panel Kits [FM121/FM123]

If your gate operator is more than 1000 ft. away from an AC power outlet, you can choose to maintain the battery charge with the Solar Panel Kit.

- 10 Watt Solar Panel Charging Kit [FM123]
- 5 Watt Solar Panel Charging Kit [FM121]



#### Replacement Battery [FM150]

For replacement or second battery.

### ENTRY AND EXIT ACCESSORIES

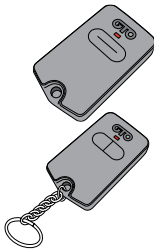

#### Transmitters [FM135/FM134/RB743]

Purchase an additional transmitter for each vehicle in your family. The Two-Button Transmitter can be programmed to operate both your gate operator and a garage door opener using the Universal Receiver [RB709U-NB]. Or it can be programmed to open two gate operator systems.

- Single Button Transmitter [FM135]
- Dual Button Transmitter [FM134]
- Three Button Transmitter [RB743]

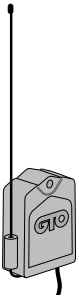

#### Universal Receiver [RB709U-NB]

The Universal Antenna Receiver gives you the ability to use one remote to activate your gate operator and your garage door opener. Connects to any brand garage door opener. Up to 100 ft. range.

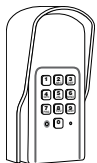

#### Digital Keypad [FM137]

Allow friends access to your property using an identification code that you provide. Program up to 25 entry codes for added security. Powered by three "AA" batteries (not included).



#### Residential Wireless Entry Intercom Keypad [FM136]

Designed for added security to your automated gate with the ability to "speak to" and "screen" visitors safely from inside your home. Ideal for securing gate entrances while providing controlled access.



#### Gooseneck Pedestal [FM100]

Designed to mount digital keypads, wireless intercom systems, and other access control devices for your gate automation system.

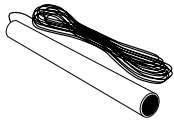

### Driveway Vehicle Sensor [FM138]

Automatically activates gate operator “Hands-Free” when a vehicle exits the property. Electromagnetic sensor detects vehicles in motion.

- 50 ft. [FM138]
- 100 ft. [FM140]
- 150 ft. [FM141]

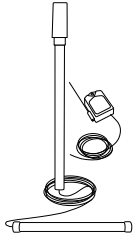

### Wireless Vehicle Sensor [FM130]

Automatically activates gate operator “Hands-Free” when a vehicle exits the property. 100 ft. range between transmitter and receiver. Easy installation.

## LOCKING & SECURITY ACCESSORIES

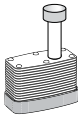

### Pin Lock [FM133]

The pin lock can be inserted in the chain bracket of the MM-LPS13 to prevent unauthorized removal of quick release pins.

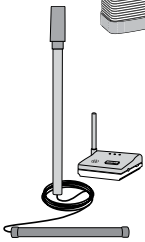

### Wireless Driveway Alarm [FM231].

This device alerts you of vehicles entering your driveway (with or without an automated gate). The indoor base station signals you with a door chime when a vehicle passes the driveway sensor.

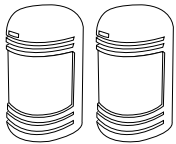

## ADDITIONAL ACCESSORIES

### Photo Beams [R4222]

Primary “through beam” photo beam device. Provides “non-contact” entrapment protection.



### Push Button Control [FM132]

Wire this unlit push button directly to your gate operator for simple open/close/stop operation from up to 1000 ft. away. Use 16 gauge low-voltage wire.

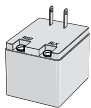

### Replacement Transformer [RB570]

Standard 18 volt, 2200 mA AC transformer included with the MM-LPS13 to maintain battery charge.



### #41 Slide Gate Chain (R4487)

The #41 chain (25’ only) is used with the MM-LPS13 DC Slide Gate Operator.

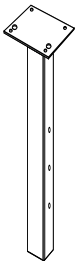

## MOUNTING OPTIONS for the MM-LPS13

### Post Mount Adapter Plate (R4983)

30 inch galvanized post mount adapter.

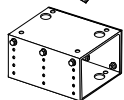

### Pad Mount Adapter Plate (R4984)

Galvanized adjustable pad mount adapter.



**3121 Hartsfield Road • Tallahassee, Florida, USA 32303  
(850) 575-0176 • Fax (850) 575-8912**

**GTO Technical Service**

**8:00am–7:00pm (EST) • Monday–Friday**

**1-800-543-1236 or (850) 575-0176 • Fax (850) 575-8912**

**Web site [www.mightymule.com](http://www.mightymule.com)**

**24/7 Troubleshooting Wizard: <http://support.gtoinc.com>**

