

# **HONDA**

---

# **ENGINES**

**GX630**  
**GX660**  
**GX690**

**TECHNICAL MANUAL**





## Preface

This manual covers engine selection, engine installation design, and engine installation testing so that the combination of a Honda engine and your equipment will make the best possible product.

Please feel free to contact your Honda Engine Distributor at any time for additional technical information or to discuss your engine application needs.

All information contained in this manual is based on the latest product information available at the time of printing. We reserve the right to make changes at any time without notice.

No part of this publication may be reproduced, or transmitted, in any form or by any means, electronic, mechanical photocopying, recording or otherwise, without the prior written permission of the publisher. This includes text, figures, and tables.

## Contents

Introduction .....	2	26A Charging System .....	16
Design Features .....	2	Power Transmission .....	16
Emission Regulations .....	2	V-Belt Connections .....	16
Recommended Power Range .....	3	Front PTO Shaft Output .....	18
Maximum Operation .....	3	Starting Performance .....	18
Continuous Operation .....	3	Installation Considerations .....	19
Power Curves .....	3	Maintenance Points Accessibility .....	19
Output Confirmation Methods .....	5	Dimensional Drawings .....	20
Cooling .....	5	Side Mount Muffler .....	21
Minimum Cooling Air Flow Requirement .....	5	High Mount Muffler .....	21
Ambient Temperature Limits .....	5	Mounting and PTO Shaft Drawings .....	22
Testing .....	5	Dimensions and Weights .....	24
Engine Enclosures .....	6	Specifications .....	25
Fuel System .....	7	Serviceability .....	25
Fuel Tank Position .....	7	Evaporative emissions (CARB Tier 3) .....	31
Fuel Line .....	7		
Fuel Valve .....	7		
Fuel Pump .....	7		
Fuel Tank Filter Installation .....	7		
Fuel-cut Solenoid .....	7		
Controls .....	7		
Engine Switch .....	7		
Carburetor Controls .....	8		
Exhaust System .....	9		
Recommended Muffler .....	9		
Fabricated Exhaust Systems .....	9		
Engine Mounting .....	10		
Inclination .....	10		
Resonance Check .....	10		
Electrical System .....	12		
Battery .....	12		
Fuse .....	12		
Battery Cables .....	12		
Engine Switch .....	12		
Charging Coil Selection .....	13		
Oil Alert® System (optional) .....	13		
Oil Pressure Switch .....	13		
Wiring Precautions .....	13		
Wiring Diagrams .....	14		
2.7A Charging systems - Remote Control Type ..	14		
Control Box Type .....	14		
17A Charging Systems - Remote Control Type ...	15		
Control Box Type .....	15		

## INTRODUCTION

Honda engines are designed for minimal maintenance. When maintenance is required, the task is kept simple by providing convenient maintenance access and procedures.

Honda engines use proven engine technology and design innovations to make them the most reliable engines.

## DESIGN FEATURES

### High Performance

The new design one-piece head/cylinder provides increased combustion efficiency and cylinder cooling capacity, allowing for higher compression and higher engine output.

Combustion efficiency has been improved through the use of a hemispherical combustion chamber with the spark plug placed closer to the center of the chamber. Cooling efficiency has been increased by combining the cylinder barrel and head, and providing external push rod tubes.

### Smooth and Quiet Operation

OHV design provides a reduced reciprocating mass and balanced weight distribution. These features and the compact design result in extremely smooth operation.

Use of proven design technologies reduces noise from internal engine components. The hardness of reciprocating parts, the helical cut gears on the crankshaft and camshaft, and the use of select materials makes these engines exceptionally quiet. The optional large mufflers are designed to further reduce noise.

### Durability/Reliability

Honda engines are built with quality that provides proven durability and reliability. Proven features such as OHV design and cast iron cylinder sleeve provide long life in all types of operating conditions. To further enhance the reliability of these engines, a 2-stage air cleaner system, electronic ignition system, mechanical centrifugal governor, and proven side-draft carburetor are standard features.

## EMISSION REGULATIONS

The Honda GX630, GX660, and GX690 engines meet U.S. Environmental Protection Agency and the California Air Resources Board regulations when fitted with a certified fuel delivery system and either a Honda genuine muffler or a certified muffler.

Honda-designed equipment integrates the engine to match the load and packaging requirements of both the engine and the product. **Honda engine distributors and equipment manufacturers that use Honda engines are required by regulation to follow this OEM technical manual.** Correct engine matching ensures that the engine will be durable (and emissions durable) in use.

Refer to the Honda *Emission Regulation Guide (TO971)* for additional emissions information.

GX690



## RECOMMENDED POWER RANGE

### Maximum Operation

Operate the engine at not more than 90% of the maximum horsepower available at a given rpm.

Recommended maximum operating bhp = 0.9 x maximum bhp

### Continuous Operation

For continuous operation (more than 30 minutes), operate the engine at not more than 80% of the maximum horsepower available at a given rpm.

Continuous recommended operating bhp = 0.8 x maximum bhp

## Power Curves

### GX630

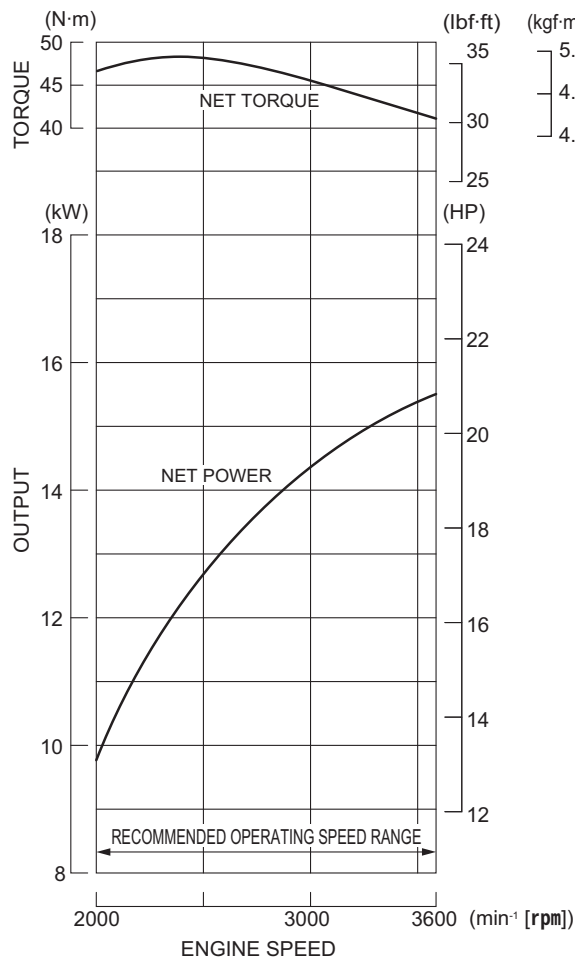

### GX660

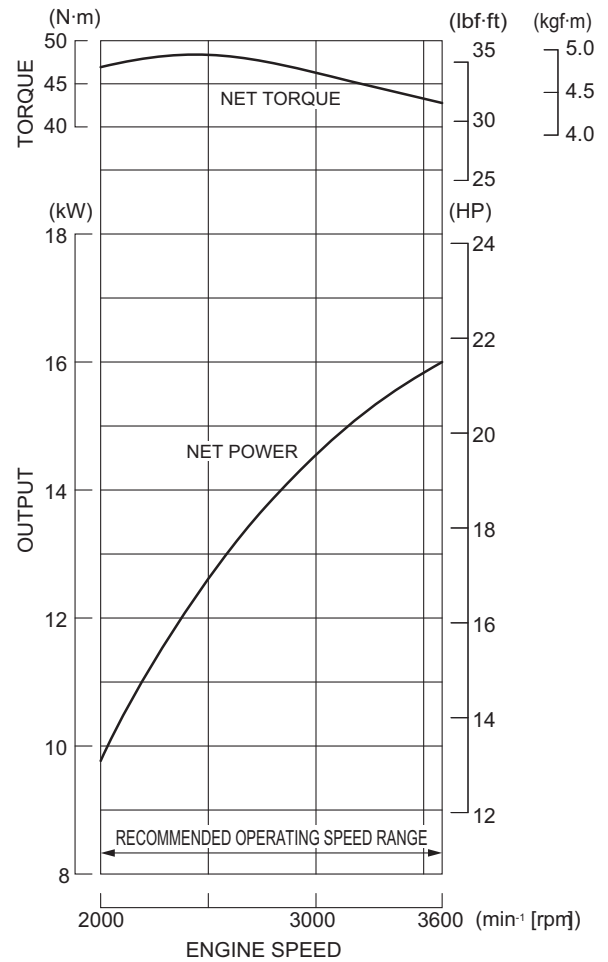

**GX690**

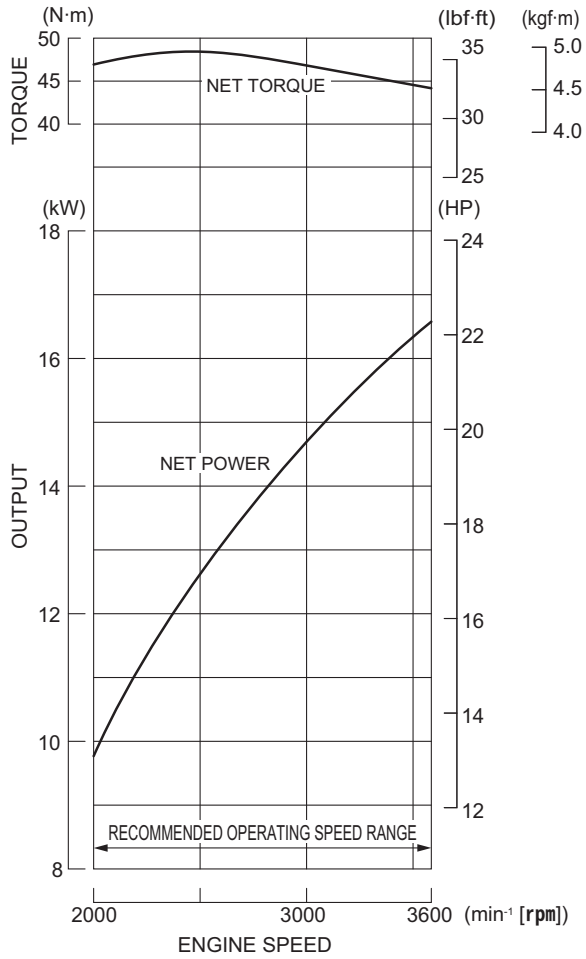

## Output Confirmation Methods

### ***Governor Rod Measurement***

When the engine is properly matched and operating at its continuous rated load, the carburetor throttle angle should be approximately half way between full open and full closed positions.

Bring the engine to normal operating temperature, and then apply the expected continuous load. If the throttle is more than halfway open, the engine is being overloaded, resulting in overheating and shortened engine life.

### ***Tachometer RPM Measurement***

Normal governor droop can also be used to measure engine load.

At rated speed: 
$$\left(1 - \frac{\text{rpm with load}}{\text{rpm without load}}\right) 100\% \leq 5\%$$

Engine is operating within the continuous recommended power range.

## COOLING

### **Minimum Cooling Air Flow Requirement**

**22 m<sup>3</sup> (777 ft<sup>3</sup>) per minute at 3,600 rpm**

Engine enclosure must have the minimum cooling airflow listed above.

### **Ambient Temperature Limits**

**-25 to +40°C (-13 to +104°F)**

### **Testing**

- Use thermocouple temperature probes at the specified locations.
- Operate the engine under worst-case conditions.
- An electronic data logger is recommended for the temperature data collection.
- Set up the data logger to take multiple readings per minute. If data is being taken manually, a reading every 5 minutes is adequate.
- Take readings until the engine temperature is stabilized at continuous rated load.
- Run the application for one hour of continuous operation; the temperatures should be stabilized in that time. If the application is used only for short intervals, note the normal run time in the application document.
- Shut the engine down and continue to take readings. Attempt to restart the engine after heat soaking.

### ***Maximum Operating Temperatures***

Spark plug seat	250 °C (482 °F)
Engine oil	140 °C (284 °F)
Gasoline at carburetor float bowl	60 °C (140 °F)
Gasoline at maximum soak	70 °C (158 °F)
Gasoline at fuel tank	60 °C (140 °F)

These temperatures are based on a maximum ambient temperature of 40°C (104°F). Compensate for any deviation linearly; i.e., if the ambient temperature is 20°C (68°F), the maximum acceptable oil temperature is 120°C (248°F).

## Engine Enclosures

### Cool Air Intake

The engine must be provided with a cooling duct so that fresh air can be drawn directly from outside the enclosure cover. Install the cooling air duct with the intake port in a place free from dust and dirt. The cooling air volume changes according to the shape of the duct and screen and the engine installation conditions. Operate the engine under the normal operating conditions and be sure that the engine meets all temperature requirements.

The cooling air duct must have a cross-sectional area of at least 300 cm<sup>2</sup> (46.5 sq. in).

When the engine is operated in dusty areas, install a filter at the enclosure inlet for the cooling air. This will reduce the effective area, so you must increase the size of the inlet accordingly. Increase the size of the inlet to the point where the maximum operating temperatures are not exceeded when operated under maximum load.

Install the cooling air duct and filter so that the filter can be easily checked and dust, dirt, and foreign material removed.

### Front PTO Output Shaft Pulley

When installing a front output pulley, make sure there is sufficient space between the pulley and screen grid or fan cover protector to enable the cooling air to flow unimpeded. The recommended distance from the pulley to the fan grid should be approximately 1/3 the diameter of the pulley. If the outside diameter (O.D.) is 150 mm, leave a space of about 45 mm. Always perform a practical test, confirming that the temperature of each part conforms to the temperature requirement.

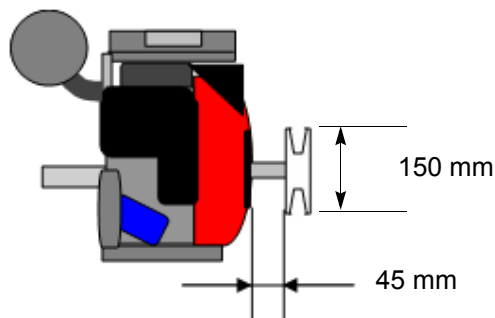

### Hot Air Discharge

Hot air must be discharged directly outside the enclosure. Provide a discharge duct if necessary. The minimum cross section of the hot air discharge opening must be larger than that of the cooling air inlet.

Locate the discharge port so the hot discharge air does not flow back into the enclosure. Provide sufficient ventilation to prevent the engine compartment temperature from rising above ambient temperature limits after the engine has been stopped.

### Exhaust Discharge

The exhaust system becomes hot during operation and remains hot for a while after operation. Separate the exhaust system from the engine compartment with a partition wall and locate the exhaust system in the discharged cooling air flow.

Be sure the exhaust gas is directly discharged outside the enclosure without being blocked or restricted by any obstacles. The exhaust gas must not flow back or be drawn back into the enclosure.

Provide the engine with an exhaust deflector or exhaust pipe extension if necessary.

If an extension pipe is used:

- Keep the length of the pipe as short as possible to keep exhaust back pressure within limits (see page 9).
- The extension pipe must have an ID larger than the OD of the muffler outlet.
- Verify the exhaust pipe extension does not create excessive vibration at any given engine rpm. If necessary, use an exhaust pipe holder to support the exhaust pipe extension.

### Grass Cutting Applications

When the engine is operated on grass cutting equipment, install a rotary screen grid on the cooling air intake port to prevent the accumulation of large clippings.

Do not allow the grass clippings shredded by the rotary screen grid to accumulate around the intake port.

## FUEL SYSTEM

This engine is supplied with an incomplete fuel system (no fuel tank, no fuel hose, etc.). As such, the OEM is responsible for ensuring evaporative emission regulations are met. See page 31 and the *Emissions Regulations Guide* for additional information.

### Fuel Tank Position

The fuel tank must be installed so that its maximum gasoline level is within 50 cm (19.5 in) above or below the carburetor gasoline level.

### Fuel Line

Use a low permeation fuel line (displaying an Executive Order number) rated for use with gasoline. The fuel line should have an inside dimension of 5.5 mm (0.22 in). Keep the fuel line as short as possible. Install the fuel line so it will not rest against any sharp objects or make sharp bends that can restrict the flow of fuel. If the fuel line passes through an enclosure wall, protect the line with a rubber grommet. Secure the fuel line with the appropriate clamping mechanism.

Route the fuel line away from hot engine and exhaust system components and away from electrical wiring. Secure the fuel line to prevent sagging and bending.

### Fuel Valve

Install the fuel valve so it is easily accessible. Install the fuel valve at the outlet of the fuel tank and use an easily read label to indicate valve location and operation. If under the fuel tank is not the ideal location, securely install the fuel valve in-line with the fuel tube in a cool location, so that engine heat cannot cause vapor lock.

### Fuel Pump

A fuel pump should be selected that provides an operating pressure of 0.1 kgf/cm<sup>2</sup> (1.4 psi) and delivers 15 liters/hr (4.0 US gal/hr). The carburetor inlet float valve has a closing pressure of 0.2 kgf/cm<sup>2</sup> (2.8 psi). If a secondary fuel pump is used, its operating pressure must not exceed the standard fuel pump's operating pressure (to prevent carburetor flooding).

### Fuel Tank Filter Installation

It is recommended that a fuel tank strainer with a mesh rating of #80 be installed at the fuel tank inlet to catch debris when refueling. It is also recommended that a fuel tank sump be provided at the fuel tank outlet to reduce the chance of contaminants entering the fuel system.

### Fuel-cut Solenoid

The fuel-cut solenoid on the carburetor takes power from the battery and there is continuity in the solenoid when the engine is running. Removing the battery when the engine is running will cause the engine to stop.

## CONTROLS

### Engine Switch

Use a three-position engine switch with continuity between its terminals as shown.

Wire Color Switch Position	IGN (BI)	GND (G)	BAT (W)	LO (BI/Y)	ST (BI/W)
OFF					
ON					
START					

## Carburetor Controls

### Installation direction:

Cable may be installed either on the left or right side.

### Types of cable:

Two types can be used, braided wire or solid wire.

### Remote Control Throttle and Choke

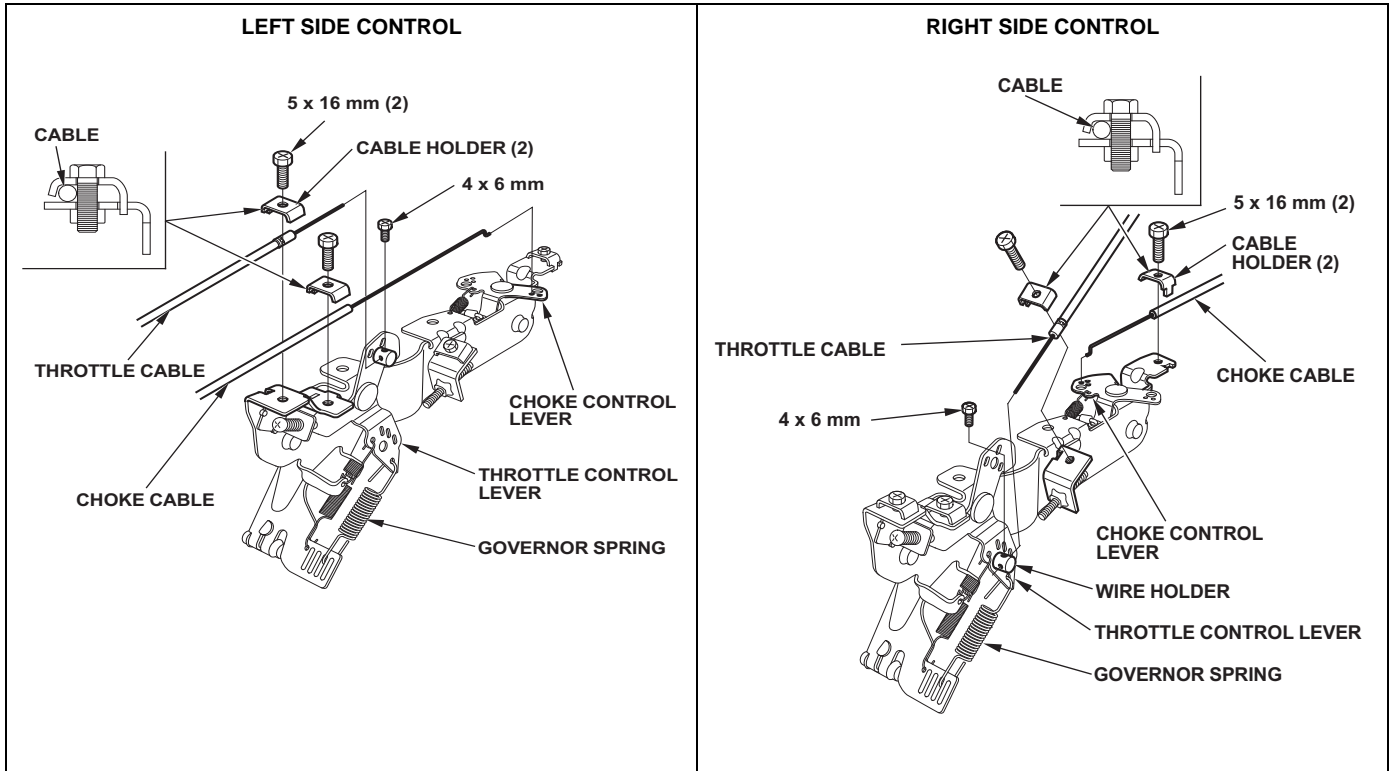

## EXHAUST SYSTEM

### Recommended Muffler

Honda mufflers and exhaust pipes are matched to the engine in terms of emissions performance, exhaust back pressure, silencing performance, durability, and installation rigidity.

Consider the following:

- Discharge the exhaust gas directly to the open air. Do not install flammable parts or any parts with poor heat resistance properties around the exhaust system or near the discharge port.
- The exhaust gas must not enter the cooling-air intake port. Be especially careful when using the exhaust deflector to change the discharge direction.
- The muffler and exhaust pipe become very hot during operation and remain hot after the engine has been shut off. Install the muffler and exhaust pipe so the fuel system and other heat-sensitive components are isolated from the exhaust heat.

### Fabricated Exhaust Systems

The muffler type and the shape and length of the exhaust pipe(s) affect emissions performance and engine power. If you use a muffler other than a recommended Honda muffler, observe the following precautions to maintain the engine's peak performance:

- The shape (bends and elbows) of the exhaust pipe can affect exhaust back pressure. If exhaust back pressure is excessive, it can affect emissions performance and/or cause detonation.
- The exhaust pipe ID must be the same size as the exhaust port diameter.
- There must be no gap between the port ID and the exhaust pipe ID.
- The exhaust back pressure increases if the diameter is less than specified. If the diameter is larger than specified, the effective width of the exhaust gasket is reduced, causing it to develop a leak.
- When the exhaust pipes are connected together before the muffler, make sure that the exhaust pipe length is as short as possible to reduce backpressure.
- Muffler volume and design will affect exhaust back pressure. Increase the volume of the muffler if exhaust back pressure is higher than specified.

### Exhaust Back Pressure Measurement

Measure the exhaust back pressure at the exhaust pipe, 30 mm (1.18 in) from the exhaust pipe mounting flange as shown (make sure the test nipple does not extend beyond the inner wall of the exhaust pipe). Pressure should be as shown below with continuous load applied. Apply the higher of the two cylinders.

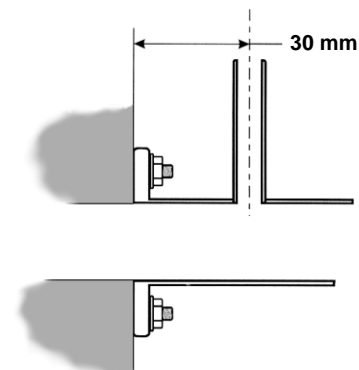

		3600 rpm		3000 rpm	
		Min.	Max	Min.	Max
GX630	kPa	7	10	5.4	7.7
	mmH <sub>2</sub> O	714	1020	551	785
GX660	kPa	6.7	9.5	5.4	7.7
	mmH <sub>2</sub> O	683	969	551	785
GX690	kPa	6.5	11	5	8.5
	mmH <sub>2</sub> O	668	1122	510	867

### **Rigid Engine Mount Muffler Installation**

The frame must be rigid to prevent cracking when the exhaust pipe and muffler are connected. The muffler should be installed securely with bolts and nuts.

The muffler should be supported at two points (or more) using special rubber mounts designed for muffler support applications.

Check to see muffler vibration does not increase at any given engine speed, causing an abnormal increase in resonance.

### **Rubber Engine Mount Muffler Installation**

A flexible pipe should be used between the muffler and exhaust pipe when the engine is mounted to the engine bed with rubber mounts. The flexible pipe ID must be the same as the exhaust pipe OD or larger.

The muffler should be supported at two points (or more) and should be installed securely with bolts and nuts to prevent muffler cracking from vibration during starting and stopping.

Check to see muffler vibration does not increase at any given engine speed, causing an abnormal increase in resonance.

## ENGINE MOUNTING

Use an engine bed or frame with enough rigidity to allow maximum durability of the engine and attachment installation.

The engine must not wobble on the engine bed. Use an engine bed or frame that provides a flat surface for the engine to be mounted on. If there is a gap between the engine and the engine bed, the engine-mounting surface may be damaged.

### **Inclination**

Horizontal mounting and operation of the engine is recommended. If the engine must be operated on a slope, the incline position of the engine must not exceed 20° in any direction.

### **Resonance Check**

There must be no resonance when the engine and attachment are operated within the designated speed range. Slowly raise the engine speed from idle to maximum and check for resonance at any engine speed.

### **General Methods for Preventing Resonance**

When engine accessories or a part of the attachment is resonating, increase the rigidity of the resonating part to bring the resonance point higher than the working engine speed range.

- Increase the rigidity of the engine bed and frame to bring the resonance point higher than the working engine speed range.
- Install the muffler on the engine body, using a rigid stay to prevent resonance of the muffler when the engine speed is within the specific operating speed range.

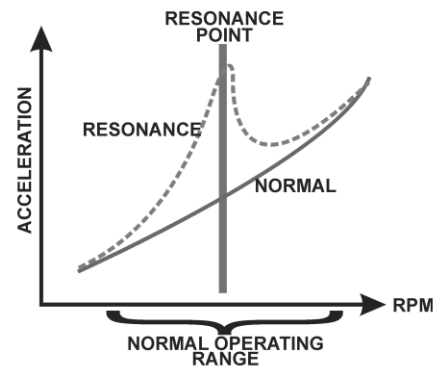

**Engine Acceleration/Vibration**

Using a vibration meter, measure the vibration amplitude on three axes (vertical, lateral, and horizontal).

Direction	Allowable G value	
	(Peak)	(RMS)
Vertical	5 (49 m/s <sup>2</sup> )	3.5 (34 m/s <sup>2</sup> )
Horizontal	5 (49 m/s <sup>2</sup> )	3.5 (34 m/s <sup>2</sup> )
lateral	5 (49 m/s <sup>2</sup> )	3.5 (34 m/s <sup>2</sup> )

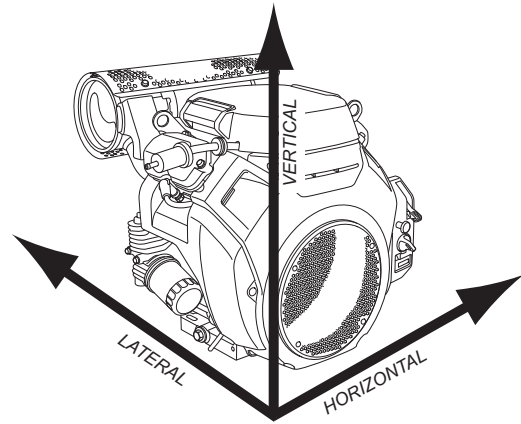

## ELECTRICAL SYSTEM

### Battery

Use a 12 V battery with a minimum capacity of 45 AH (400 CCA).

### Fuse

Recommended fuse size:

Charging system (A)	Fuse (A)
2.7.0	30
17.0	30
26.0	40

### Battery Cables

Select battery cables to avoid greater than 0.5 volt drop in the cable during starter motor operation.

*Battery cable size and length: (Gauge x Length)*

Positive cable: AWG No. 4 x 1.5 m (5.0 ft.) maximum

Negative cable: AWG No. 4 x 2.3 m (7.5 ft.) maximum

Types with Oil Alert: Attach the negative battery cable from the battery directly to the outer mounting bolt of the electric starter.

### Engine Switch

Use a three-position engine switch with continuity between its terminals as shown.

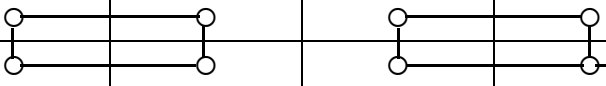
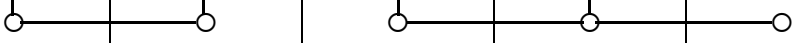
Wire Color Switch Position	IGN (BI)	GND (G)	BAT (W)	LO (BI/Y)	ST (BI/W)
OFF					
ON					
START					
Vdc/A (rated)	5/15mA		12/1A	12/13A	12/12A
Dia. (recommended)	AV0.5	AV0.5	AV0.5	AV2.0	AV1.25

The ignition circuit has continuity during operation, and goes open after the engine stops. (Open stop)

Use a switch of waterproof construction to ensure reliable ignition.

Contact resistance of the combination switch: No more than 200 mΩ.

Recommended length of the harness to the combination switch: No more than 2 m.

When setting the harness, make sure that electromagnetic noise transmitted via the harness does not affect the engine. If the engine is likely to be adversely affected by noise, use shielded wire or change the harness routing.

## Charging Coil Selection

Three types of coils are available:

Coil	Output (A)		Regulated
	Min/1000 rpm	Max/4000 rpm	
2.7A	1.3	3.5	No
17A	6.5	20	Yes
26A	11	30	Yes

The 2.7A coil is only suitable for recharging a starting battery. Use the larger coils when powering accessories.

The regulator/rectifier has cooling fins integrated with the assembly. Install the regulator/rectifier in a place where the ambient temperature is lower than 40°C (104°F) and there is a fresh supply of cool air passing over the cooling fins.

Mount the regulator/rectifier on the frame so that the vibration is 10 g (98 m/s<sup>2</sup>) maximum. Do not install it on the engine.

Install the appropriate fuse between the engine switch and the starter solenoid battery lead to protect the regulator rectifier circuits: 30A for 2.7A and 17A coil; 40A for the 26A coil.

## Oil Alert<sup>®</sup> System (optional)

The Oil Alert System uses a float type switch located inside the crankcase. When the engine oil level falls below a safe operating level, the float falls and the circuit is completed through the control box, grounding the primary side of the ignition coil. The Oil Alert System is only recommended for use on equipment that is stationary while operating.

## Oil Pressure Switch

The oil pressure switch is normally closed, completing the circuit between its terminal and ground. The circuit is opened when the operating pressure is above 1.0 kg/cm<sup>2</sup> (98 kPa, 14.22 psi). The oil pressure switch can be wired to a warning device such as a buzzer (12 Vdc 0.3A or above) or a lamp (12V 3.4W maximum).

## Wiring Precautions

- Connect the battery positive (+) cable to the positive terminal of the starter solenoid.
- Connect the battery negative (–) cable to the engine crankcase or engine frame mounting bolt.
- Do not route the battery cables on or near any hot, moving, or rotating parts, or sharp edges. Keep the battery cables and electrical wires away from the fuel line.
- Protect positive electrical connections with a cover or insulation.
- Types with Oil Alert: Attach the negative battery cable from the battery directly to the outer mounting bolt of the electric starter.

WIRING DIAGRAMS

2.7A Charging systems - Remote Control Type

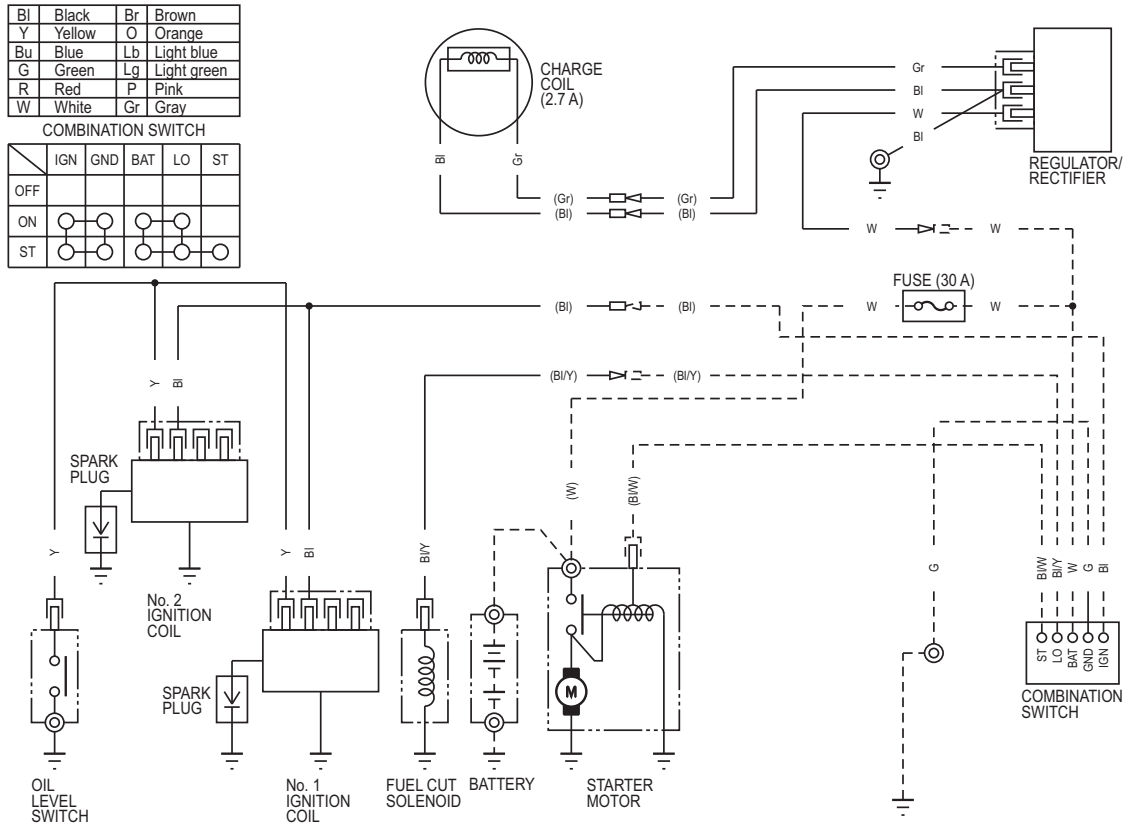

Control Box Type

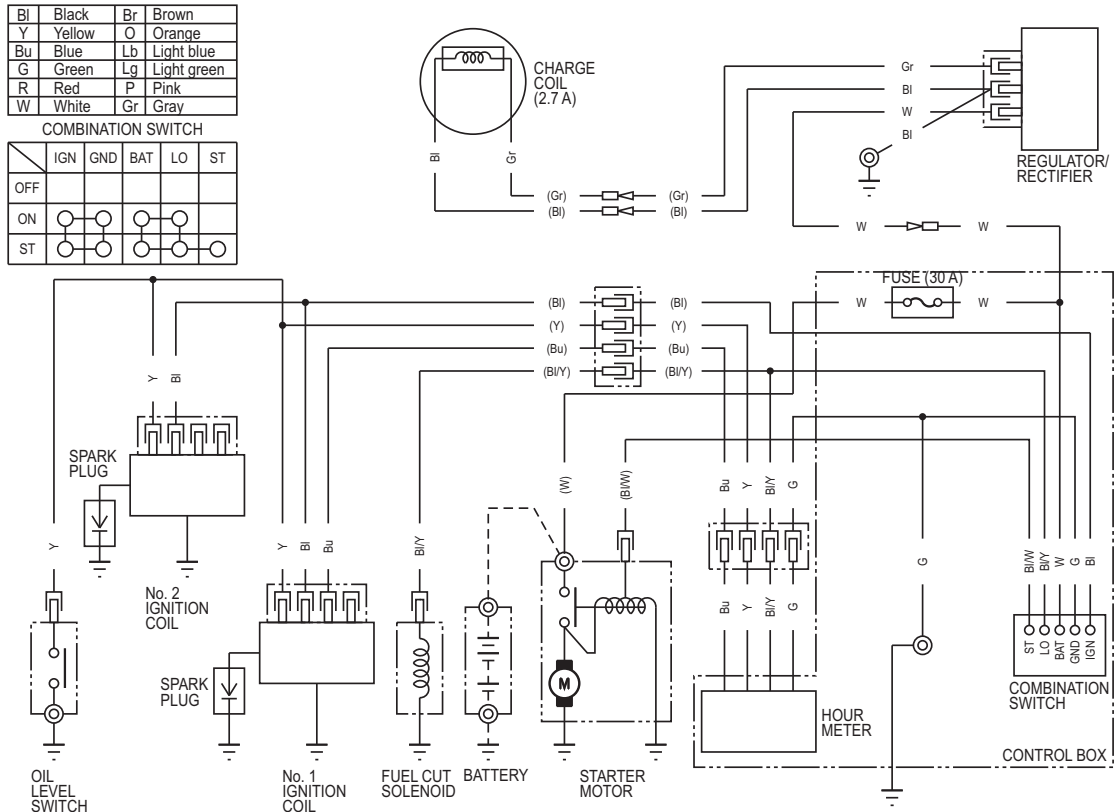

### 17A Charging Systems - Remote Control Type

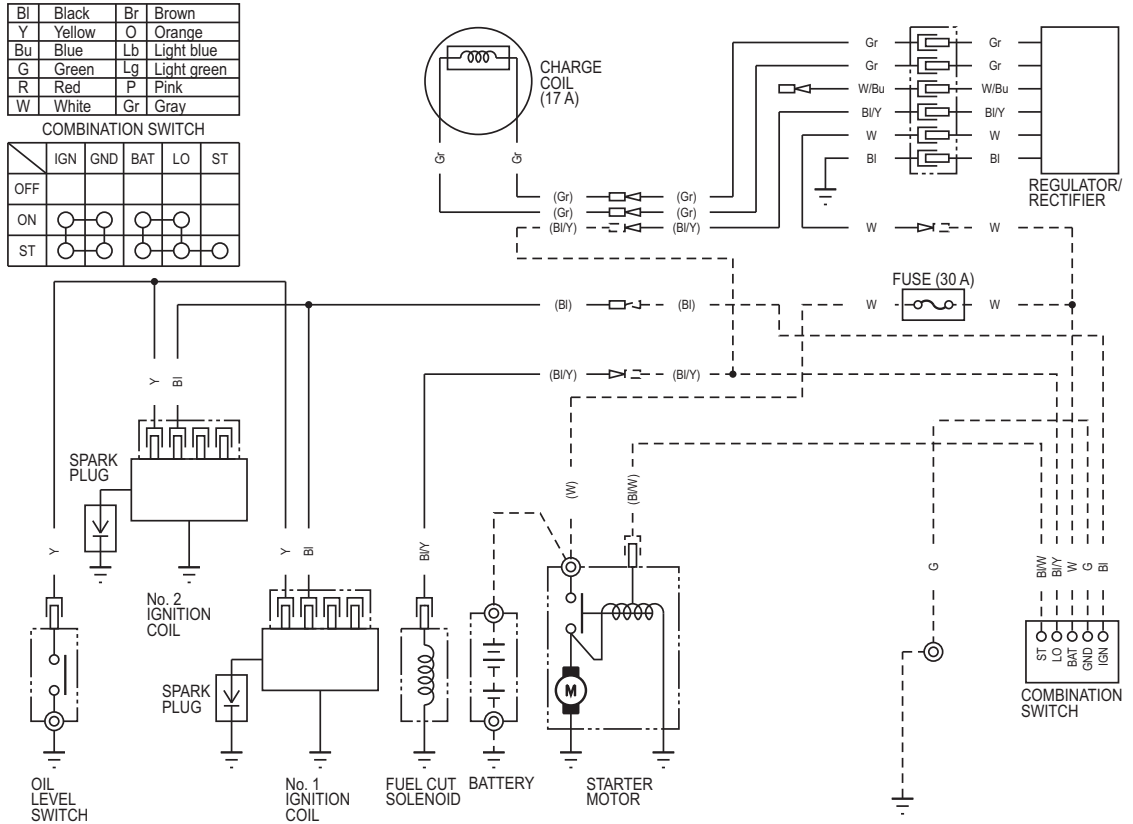

### Control Box Type

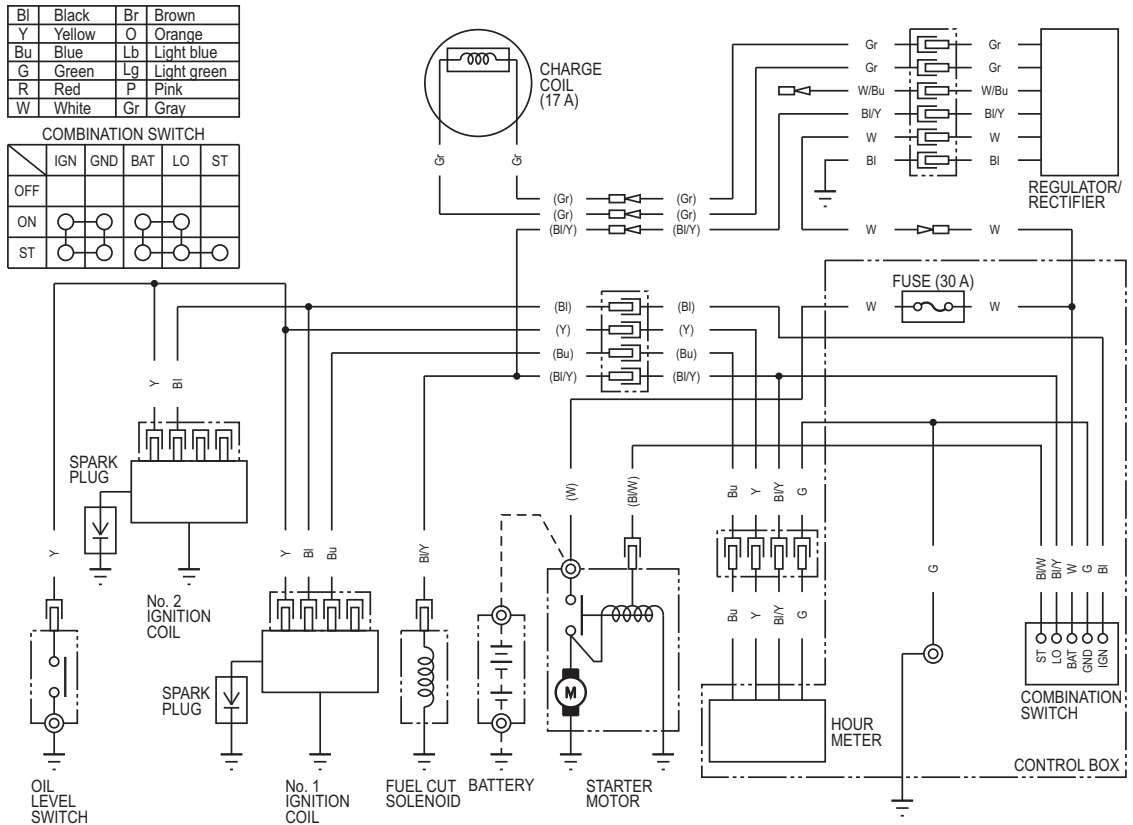

## 26A Charging System

Bl	Black	Br	Brown
Y	Yellow	O	Orange
Bu	Blue	Lb	Light blue
G	Green	Lg	Light green
R	Red	P	Pink
W	White	Gr	Gray

COMBINATION SWITCH

	IGN	GND	BAT	LO	ST
OFF					
ON	○	○	○	○	
ST	○	○	○	○	○

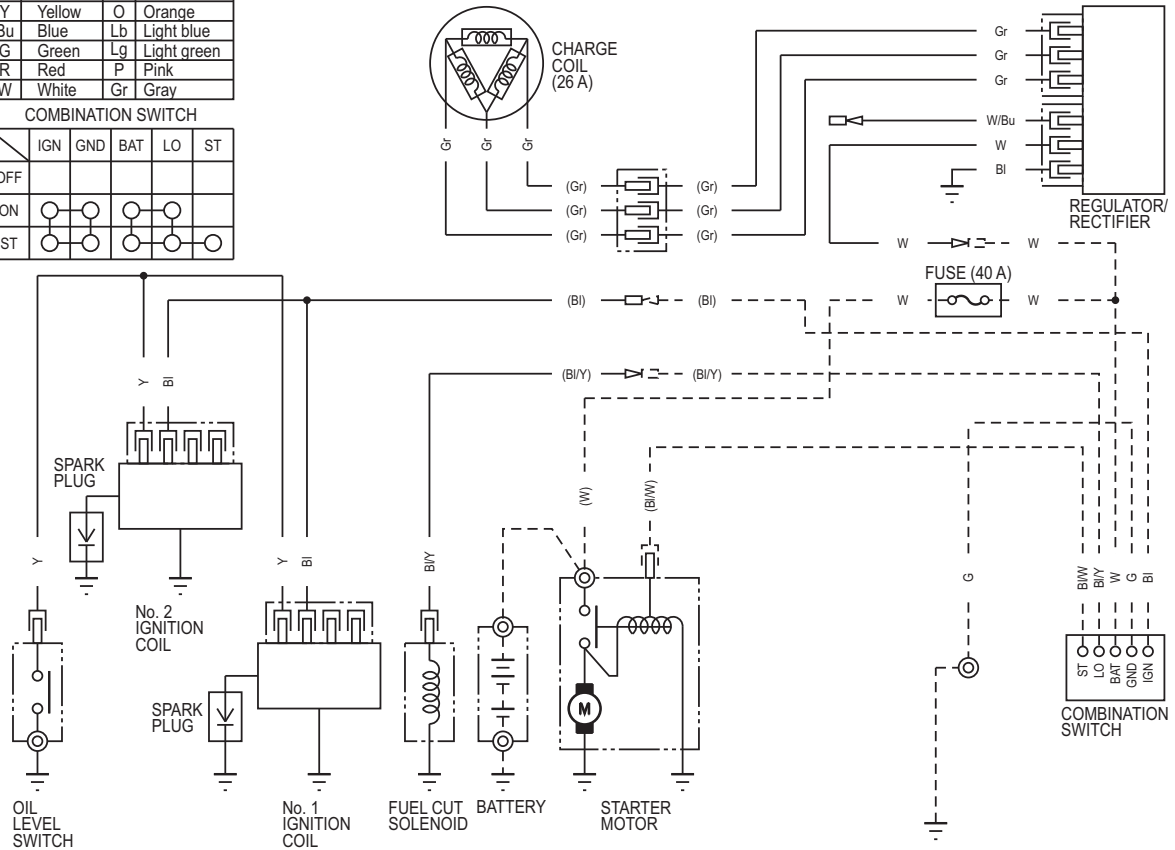

## POWER TRANSMISSION

### V-Belt Connections

Be sure there is no static axial load applied to the crankshaft.

Install the pulley as close to the base of the PTO shaft as possible. When installing the pulley at the end of the PTO shaft, be sure the overhang of the pulley is less than 50 mm (2.0 in) as shown.

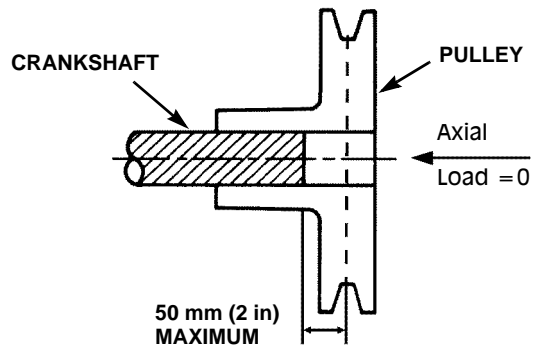

Before securing the engine and attachment to the engine bed, verify that the V-groove of the engine pulley and attachment pulley are aligned and that the engine PTO shaft and attachment driven shaft are parallel.

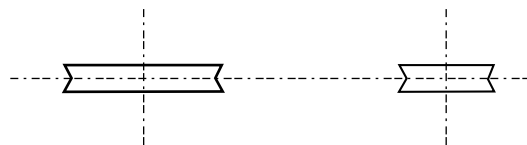

When installing a pulley on the PTO shaft, use a tapered pulley bushing for security. This is a very effective method in preventing the pulley from working loose when the inertia moment of the pulley and torque fluctuation is large.

The frame or engine bed must be rigid enough to prevent belt resonance in the working speed range of the engine. Size the pulleys so they do not cause resonance of the belt(s).

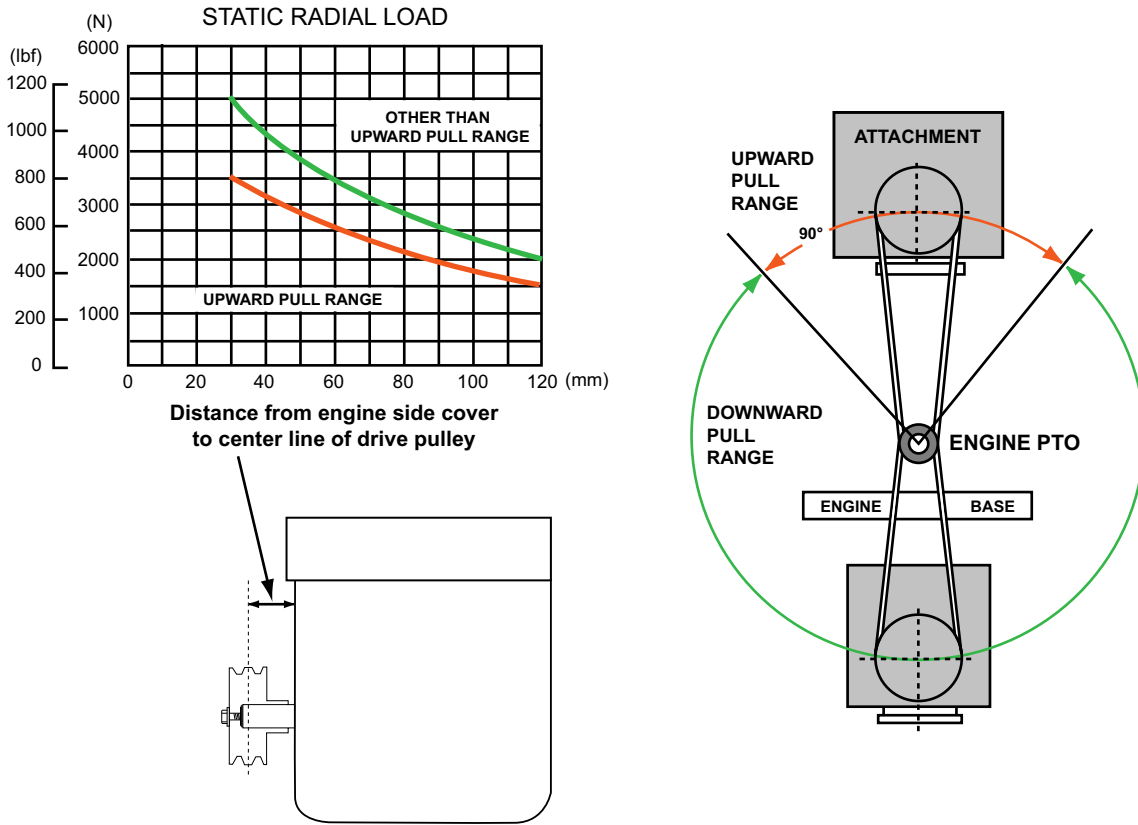

To reduce resonance, install a stay between the engine and attachment as shown below.

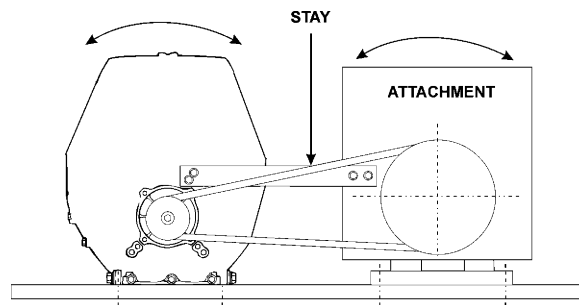

### Front PTO Shaft Output

- Power output from the flywheel PTO should not exceed 50% of the net power.
- Use a rubber coupling or similar material to prevent an impact load from being applied directly to the PTO.
- Pulley/belt usage:
  - The pulley must be mounted away from the screen grid to provide adequate cooling (page 6).
  - The pulley overhang must not exceed 150 mm (6 in).
  - The belt load must be within the range of values shown in the graph below.

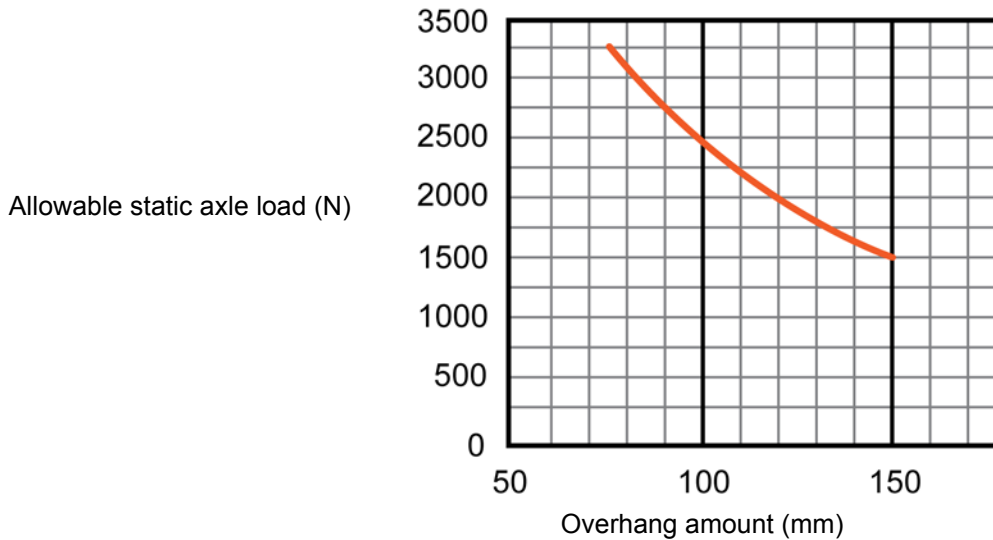

### Starting Performance

The engine must be able to start with the attachment at the lowest recommended ambient temperature (-25°C, -13°F).

If the starting load of the attachment is too large when operating the starter motor, provide a clutch so you can separate the load from the engine when operating the starter.

Due to changes in oil viscosity, there will be an increased drag in attachments such as hydraulic pumps or gear cases as temperature drops. Start the engine with the ambient temperature at the lowest temperature recommended for operating the attachment. Verify that the attachment, as well as the engine, can start and operate normally.

Select the proper oil viscosity for the attachment according to the attachment's working temperature.

Minimum engine cranking voltage	9.6 Vdc
Minimum engine cranking rpm	250 rpm
Maximum engine cranking amperage	200 A

## INSTALLATION CONSIDERATIONS

### Maintenance Points Accessibility

When the engine is installed in an enclosure, provide an access panel or use an engine enclosure that can be opened and closed easily. See also Serviceability page 25.

The emission control information label on the engine must be visible when the engine is installed in the equipment. If it is not visible by removing a panel, lifting a hood, or other means not using tools, you must attach a supplemental label. See the Honda *Emission Regulation Guide* (TO971).

#### Left-front Side

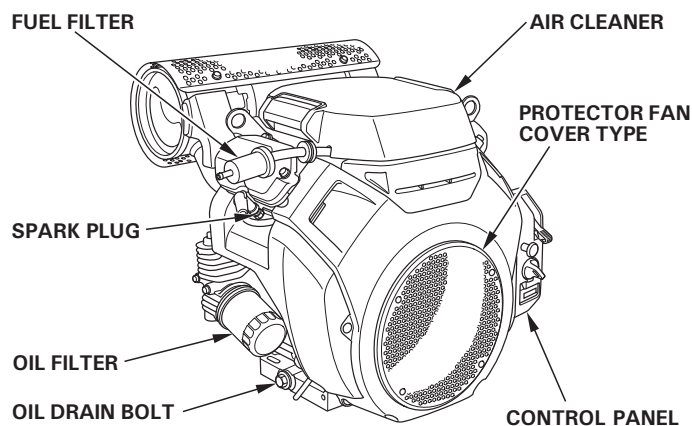

#### Right-rear Side

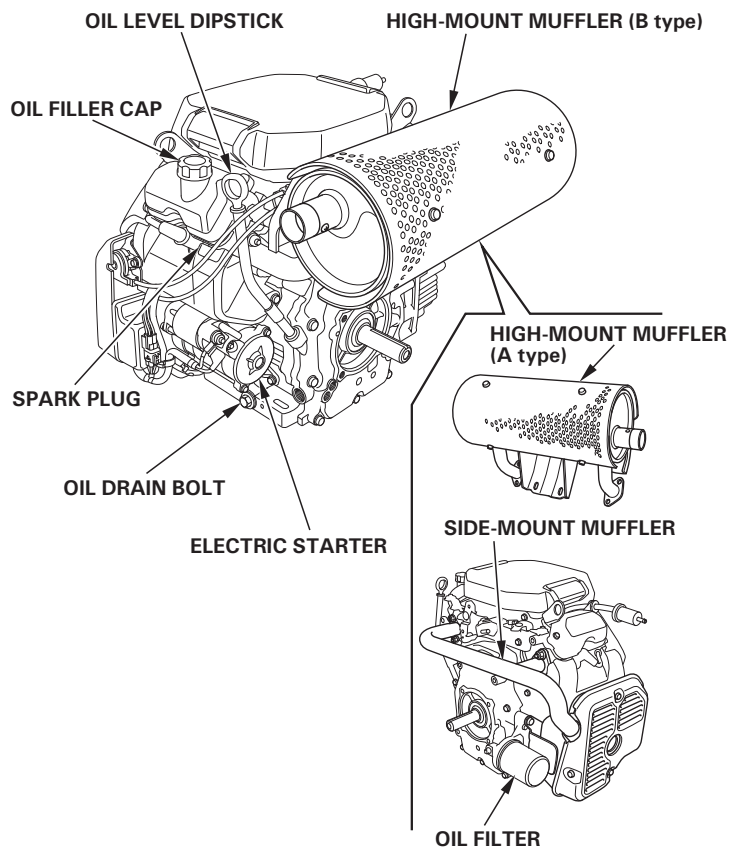

DIMENSIONAL DRAWINGS

unit: mm (in)

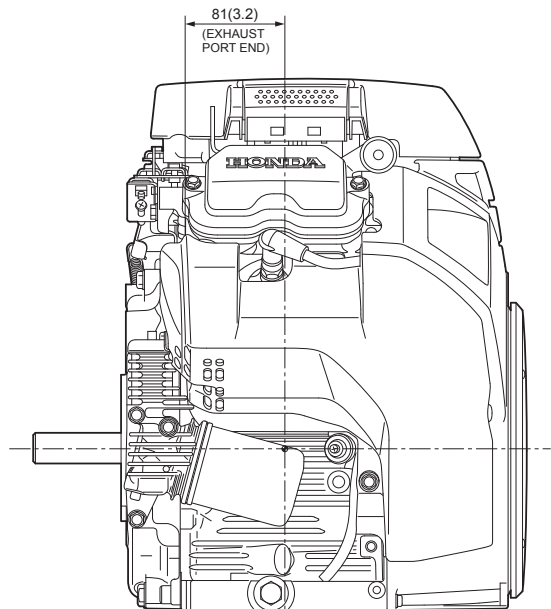
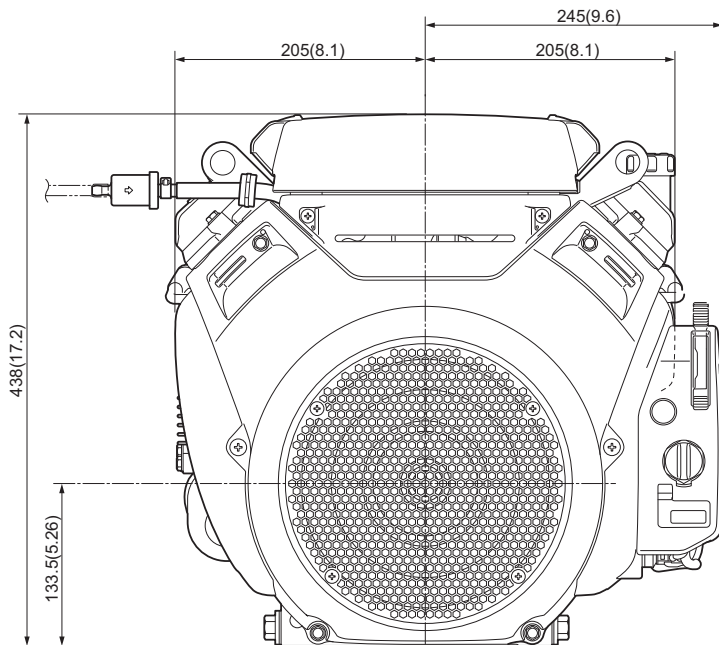
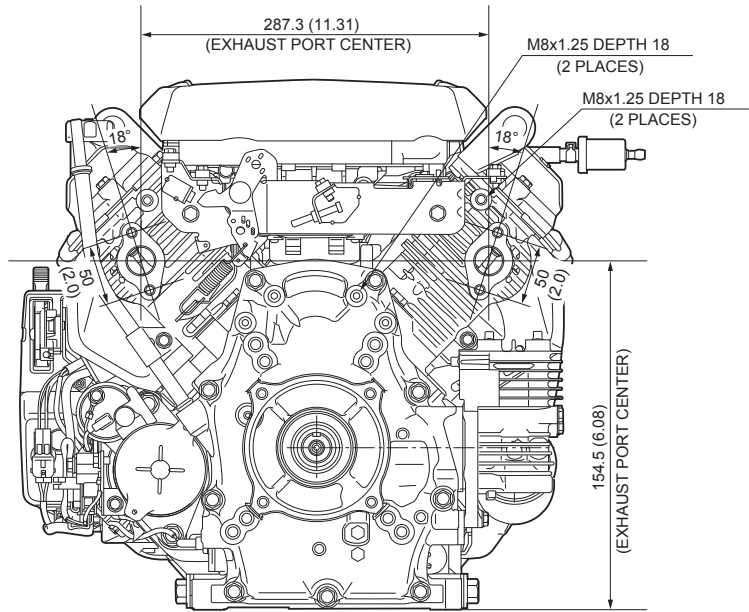
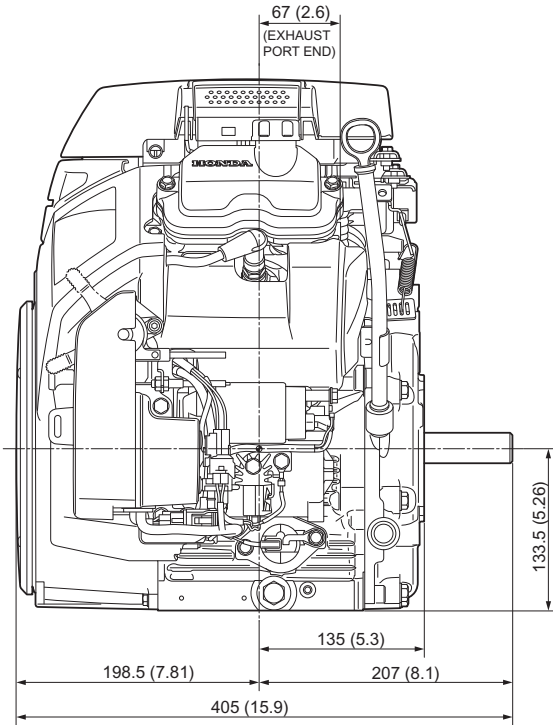

## Side Mount Muffler

unit: mm (in)

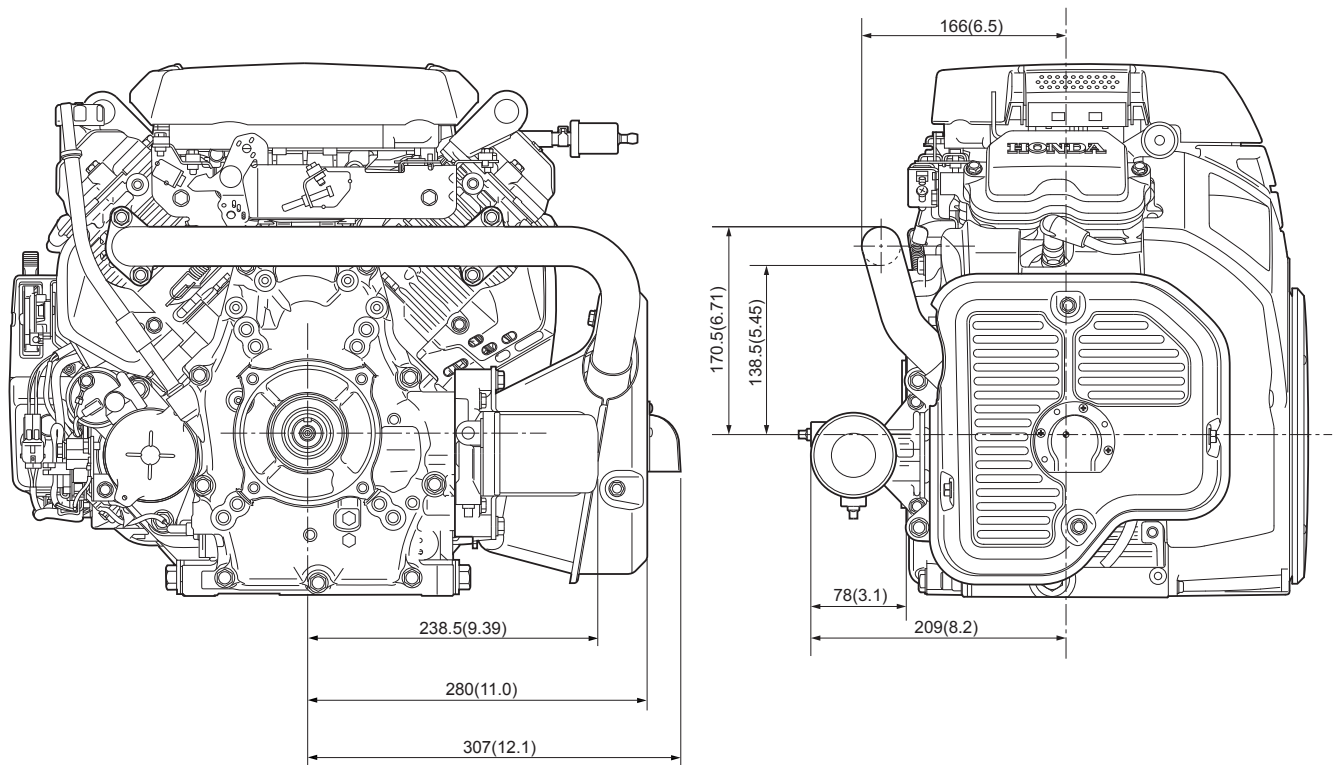

## High Mount Muffler

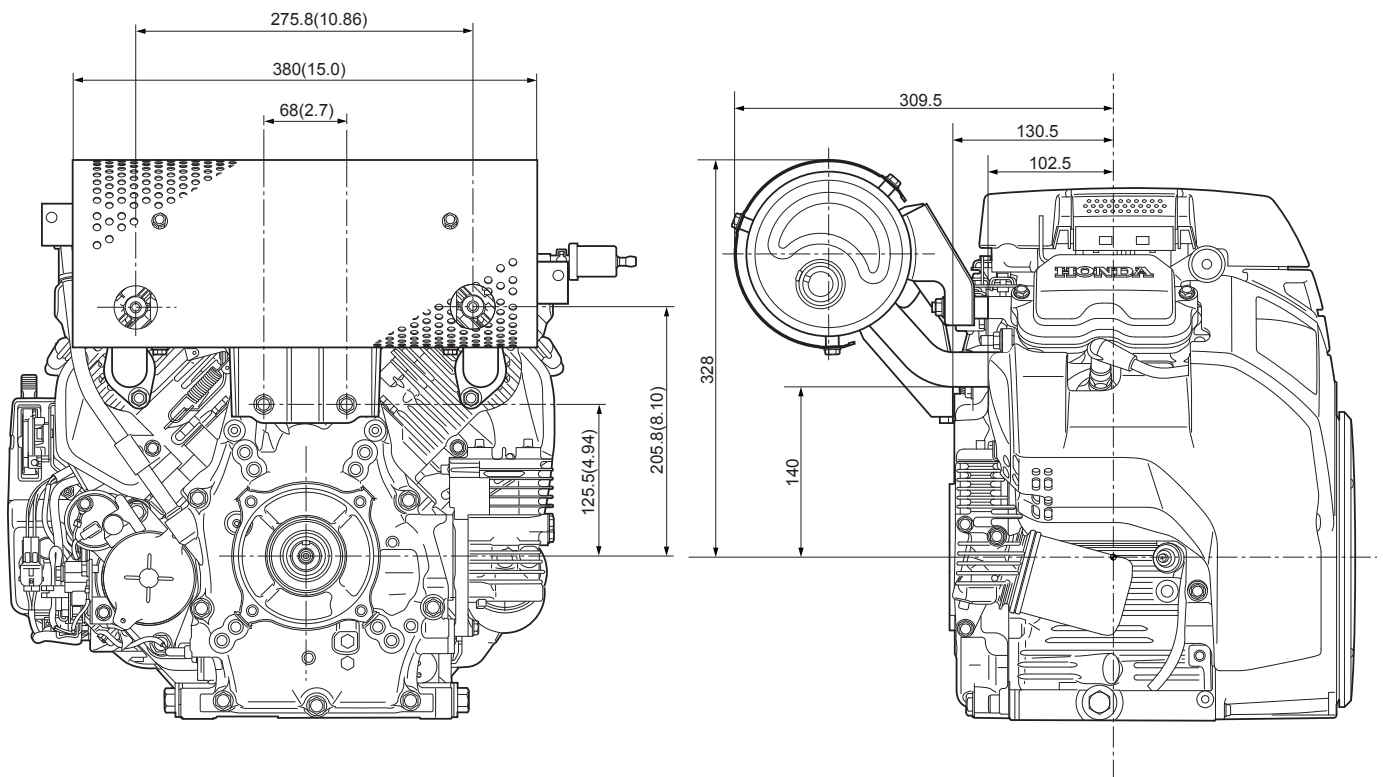

Mounting and PTO Shaft Drawings

unit: mm (in)

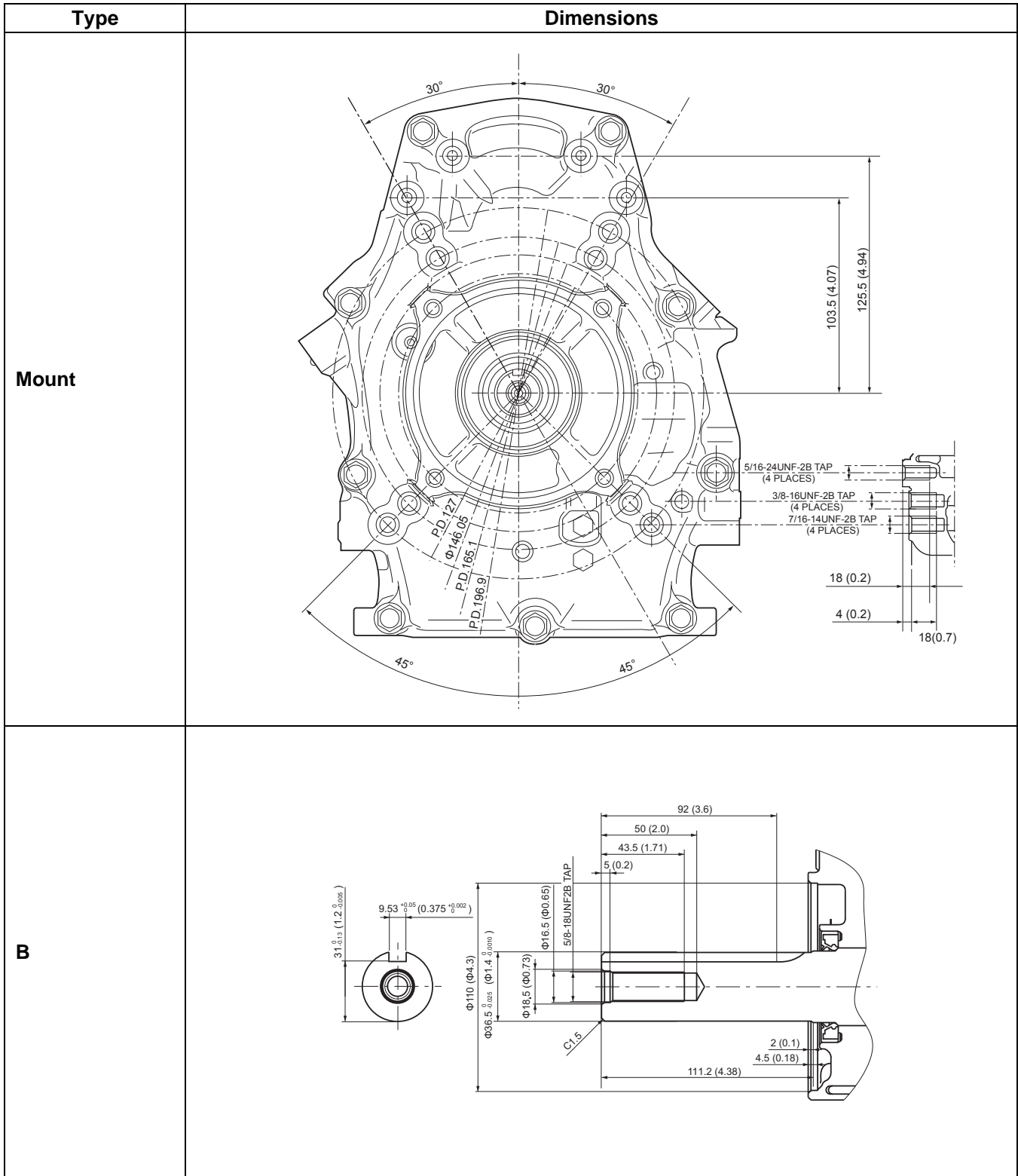

Type	Dimensions
Q	
S	
T	

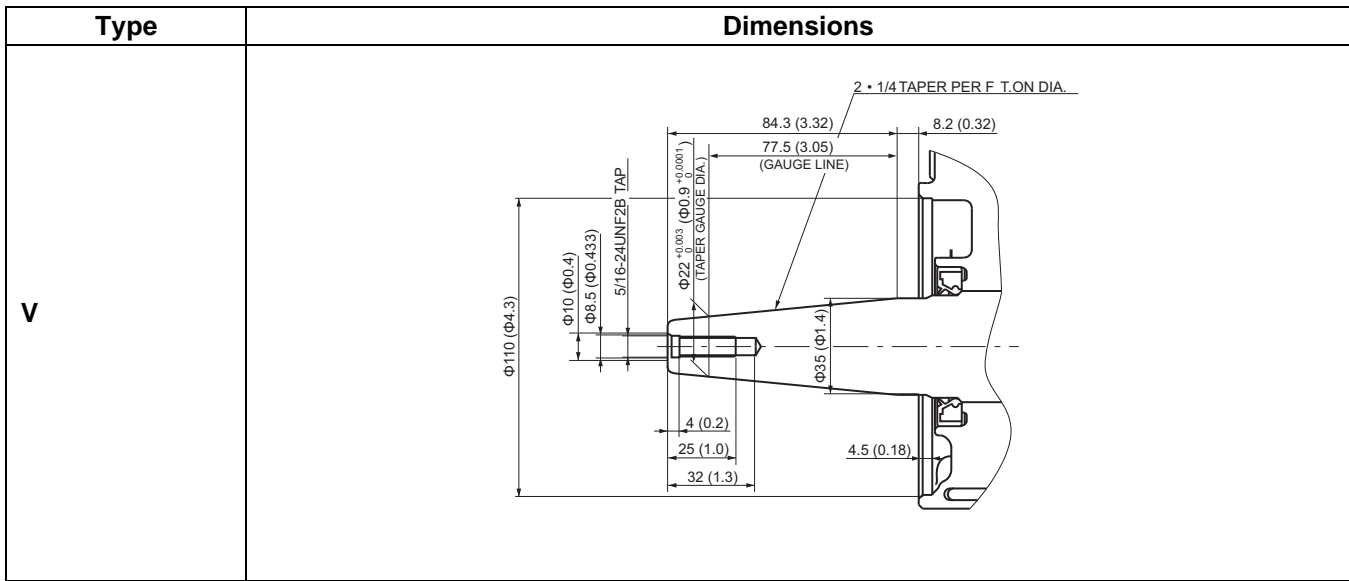

### DIMENSIONS AND WEIGHTS

Model	GX630R	GX660R	GX690R
Overall length	Q type: 405 mm (15.9 in) V type: 426 mm (16.8 in) S type: 396 mm (15.6 in) T type: 429 mm (16.9 in) B type: 442 mm (17.4 in) DEN type: 371 mm (14.6 in)		
Overall width	410 mm (16.1 in)		
Overall height	438 mm (17.2 in)		
Dry weight	Q, S types: 44.4 kg (97.9 lbs) V, T types: 44.6 kg (98.3 lbs) B type: 45.0 kg (99.2 lbs) DEN type: 44.3 kg (97.7 lbs)		
Operating weight	Q, S types: 46.0 kg (101.4 lbs) V, T types: 46.2 kg (101.9 lbs) B type: 46.6 kg (102.7 lbs) DEN type: 45.9 kg (101.2 lbs)		
Maximum angle of inclination	Forward and backward: 20° Left and right: 20°		

## SPECIFICATIONS

Model	GX630R	GX660R	GX690R
Description code	GCBEK	GCBFK	GCBGK
Type	4 stroke, overhead valve, 90° V-twin cylinder		
Displacement	688.0 cm <sup>3</sup> (41.97 cu-in)		
Bore x stroke	78.0 x 72.0 mm (3.07 x 2.83 in)		
Net power (SAE J1349)*	15.5 kW (20.8 HP) / 3,600 min <sup>-1</sup> (rpm)	16.0 kW (21.5 HP) / 3,600 min <sup>-1</sup> (rpm)	16.5 kW (22.1 HP) / 3,600 min <sup>-1</sup> (rpm)
Continuous rated power	12 kW (16.1 HP) / 3,600 min <sup>-1</sup> (rpm)	12.5 kW (16.8 HP) / 3,600 min <sup>-1</sup> (rpm)	13 kW (17.4 HP) / 3,600 min <sup>-1</sup> (rpm)
Maximum net torque (SAE J1349)*	48.3 N·m (4.93 kgf·m, 35.6 lbf-ft) / 2,500 min <sup>-1</sup> (rpm)	48.3 N·m (4.93 kgf·m, 35.6 lbf-ft) / 2,500 min <sup>-1</sup> (rpm)	48.3 N·m (4.93 kgf·m, 35.6 lbf-ft) / 2,500 min <sup>-1</sup> (rpm)
Maximum rpm (at no load)	3,850 ± 150 min <sup>-1</sup> (rpm)		
Compression ratio	9.3 ± 0.2		
Fuel consumption (at continuous rated power)	6.0 Liters (1.59 US gal, 1.32 Imp gal) / h	6.3 Liters (1.66 US gal, 1.39 Imp gal) / h	6.7 Liters (1.77 US gal, 1.47 Imp gal) / h
Ignition system	C.D.I.(Capacitor Discharge Ignition) type magneto		
Ignition timing	B.T.D.C. 9° / 1,000 min <sup>-1</sup> (rpm)		
Spark advancer type	Electronic type		
Spark advancer performance	B.T.D.C. 9° – 23°		
Spark plug	ZFR5F (NGK)		
Lubrication system	Forced feed		
Oil capacity	Without oil filter replacement: 1.5 Liters (1.59 US qt, 1.32 Imp qt) With oil filter replacement: 1.7 Liters (1.80 US qt, 1.50 Imp qt)		
Recommended oil	SAE 10W-30 API service classification SJ or later		
Cooling system	Forced air		
Starting system	Starter motor		
Stopping system	Ignition circuit open		
Carburetor	2 barrel horizontal type, butterfly valve		
Air cleaner	Dual type		
Governor	Mechanical centrifugal		
Breather system	Reed valve type, PCV (Positive Crankcase Ventilation) type		
Fuel used	Unleaded gasoline with a pump octane rating 86 or higher		

\*: The power rating of the engine indicated in this document is the net power output tested on a production engine for the engine model and measured in accordance with SAE J1349 at 3,600 rpm (net power) and at 2,500 rpm (max net torque). Mass production engines may vary from this value. Actual power output for the engine installed in the final machine will vary depending on numerous factors, including the operating speed of the engine in application, environmental conditions, maintenance, and other variables.

## SERVICEABILITY

The following Maintenance section is duplicated from the applicable owner's manual and is accurate at the time of publication of this manual. It is provided for your reference in considering serviceability issues.

**SAFETY PRECAUTIONS**

- Make sure the engine is off before you begin any maintenance or repairs. To prevent accidental startup, disconnect the spark plug cap. This will eliminate several potential hazards:
  - **Carbon monoxide poisoning from engine exhaust.**  
Operate outside, away from open windows or doors.
  - **Burns from hot parts.**  
Let the engine and exhaust system cool before touching.
  - **Injury from moving parts.**  
Do not run the engine unless instructed to do so.
- Read the instructions before you begin, and make sure you have the tools and skills required.
- To reduce the possibility of fire or explosion, be careful when working around gasoline. Use only a non-flammable solvent, not gasoline, to clean parts. Keep cigarettes, sparks and flames away from all fuel related parts.

Remember that an authorized Honda servicing dealer knows your engine best and is fully equipped to maintain and repair it.

To ensure the best quality and reliability, use only new Honda Genuine parts or their equivalents for repair and replacement.

**MAINTENANCE SCHEDULE**

REGULAR SERVICE PERIOD (3) Perform at every indicated month or operating hour interval, whichever comes first.		Each Use	First Month or 20 Hrs	Every 6 Months or 100 Hrs	Every Year or 300 Hrs	Every 2 Years or 500 Hrs	Refer to Page
ITEM	Engine oil Check level	○					8
	Change		○	○			8
Engine oil filter	Replace		Every 200 Hrs.				9
Air cleaner	Check	○					9
	Clean			○ (1)			9
	Replace					○ *	
Spark plug	Check-adjust			○			10
	Replace				○		
Spark arrester (applicable types )	Clean			○			11
Idle speed	Check-adjust				○ (2)		**
Valve clearance	Check-adjust				○ (2)		**
Combustion chamber	Clean		After every 1000 Hrs. (2)				**
Fuel filter	Replace				○ (2)		**
Fuel tube	Check		Every 2 years (Replace if necessary) (2)				**

- \* Replace the paper filter element only.
- \*\* Refer to the Shop Manual.

- (1) Service more frequently when used in dusty areas.
- (2) These items should be serviced by your Honda servicing dealer, unless you have the proper tools and are mechanically proficient. Refer to the Honda shop manual for service procedures.
- (3) For commercial use, log hours of operation to determine proper maintenance intervals.

Failure to follow this maintenance schedule could result in non-warrantable failures.

**REFUELING**

**Recommended Fuel**

Unleaded gasoline		
U.S.		Pump octane rating 86 or higher
Except U.S.		Research octane rating 91 or higher
		Pump octane rating 86 or higher

This engine is certified to operate on unleaded gasoline with a pump octane rating of 86 or higher (a research octane rating of 91 or higher).

Refuel in a well ventilated area with the engine stopped. If the engine has been running, allow it to cool first. Never refuel the engine inside a building where gasoline fumes may reach flames or sparks.

You may use unleaded gasoline containing no more than 10% ethanol (E10) or 5% methanol by volume. In addition, methanol must contain cosolvents and corrosion inhibitors. Use of fuels with content of ethanol or methanol greater than shown above may cause starting and/or performance problems. It may also damage metal, rubber, and plastic parts of the fuel system. Engine damage or performance problems that result from using a fuel with percentages of ethanol or methanol greater than shown above are not covered under the Warranty.

If your equipment will be used on an infrequent or intermittent basis, please refer to the fuel section of the STORING YOUR ENGINE chapter (see page 11 ) for additional information regarding fuel deterioration.

**⚠ WARNING**

Gasoline is highly flammable and explosive, and you can be burned or seriously injured when refueling.

- Stop the engine and keep heat, sparks, and flame away.
- Refuel only outdoors.
- Wipe up spills immediately.

**NOTICE**

*Fuel can damage paint and some types of plastic. Be careful not to spill fuel when filling your fuel tank. Damage caused by spilled fuel is not covered under the Distributor's Limited Warranty.*

Never use stale or contaminated gasoline or an oil/gasoline mixture. Avoid getting dirt or water in the fuel tank.

With the engine stopped and on a level surface, remove the fuel filler cap and check the fuel level. Refill the tank if the fuel level is low.

Refer to the instructions provided with the equipment powered by this engine for refuelling.

Refuel in a well-ventilated area before starting the engine. If the engine has been running, allow it to cool. Refuel carefully to avoid spilling fuel. It may be necessary to lower the fuel level depending on operating conditions. After refueling, tighten the fuel tank cap securely.

Keep gasoline away from appliance pilot lights, barbecues, electric appliances, power tools, etc.

Spilled fuel is not only a fire hazard, it causes environmental damage. Wipe up spills immediately.

### ENGINE OIL

Oil is a major factor affecting performance and service life. Use 4-stroke automotive detergent oil.

#### Recommended Oil

Use 4-stroke motor oil that meets or exceeds the requirements for API service category SJ or later (or equivalent). Always check the API service label on the oil container to be sure it includes the letters SJ or later (or equivalent).

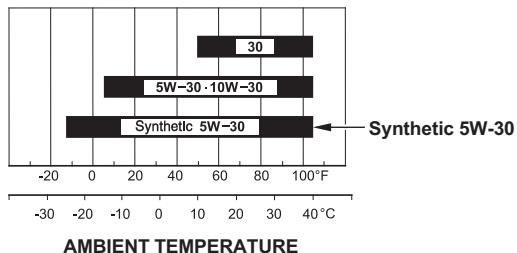

SAE 10W-30 or 5W-30 is recommended for general use. Use a full synthetic 5W-30 for starting/operating temperatures between 5°F (-15°C) and -13°F (-25°C). Other viscosities shown in the chart may be used when the average temperature in your area is within the indicated range.

#### Oil Level Check

Check the engine oil level with the engine stopped and in a level position.

1. Start the engine and let it idle for 1 or 2 minutes. Stop the engine and wait for 2 or 3 minutes.
2. Remove the oil level dipstick and wipe it clean.
3. Fully insert the oil level dipstick, then remove it to check the oil level.
4. If the oil level is low, remove the oil filler cap, and fill with the recommended oil to the upper limit mark on the oil level dipstick.
5. Reinstall the oil level dipstick and oil filler cap.

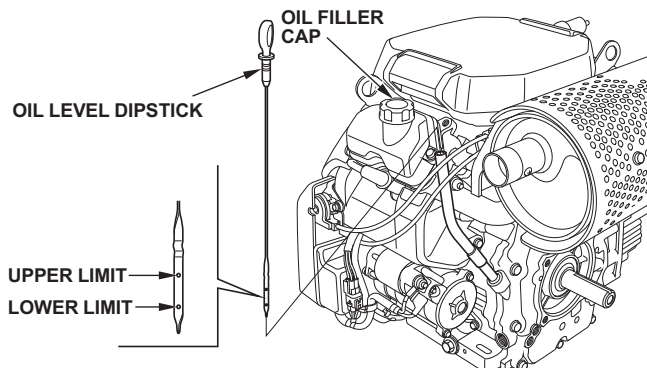

#### NOTICE

Running the engine with a low oil level can cause engine damage. This type of damage is not covered by the Distributor's Limited Warranty.

The Oil Alert system (applicable types) will automatically stop the engine before the oil level falls below the safe limit. However, to avoid the inconvenience of an unexpected shutdown, always check the engine oil level before startup.

### Oil Change

Drain the used oil when the engine is warm. Warm oil drains quickly and completely.

1. Place a suitable container below the engine to catch the used oil, then remove the oil filler cap, drain bolt and sealing washer.
2. Allow the used oil to drain completely, then reinstall the drain bolt and new sealing washer, and tighten the drain bolt securely.

Please dispose of used motor oil in a manner that is compatible with the environment. We suggest you take used oil in a sealed container to your local recycling center or service station for reclamation. Do not throw it in the trash, pour it on the ground, or pour it down a drain.

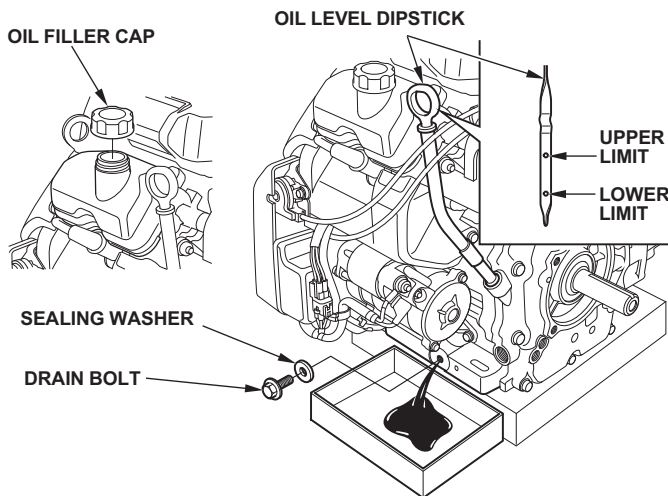

3. With the engine in a level position, fill with the recommended oil to the upper limit mark on the oil level dipstick.

#### NOTICE

Running the engine with a low oil level can cause engine damage. This type of damage is not covered by the Distributor's Limited Warranty.

The Oil Alert system (applicable types) will automatically stop the engine before the oil level falls below the safe limit. However, to avoid the inconvenience of an unexpected shutdown, fill to the upper limit, and check the oil level regularly.

4. Reinstall the oil filler cap and oil level dipstick securely.

## OIL FILTER

### Change

1. Drain the engine oil, and retighten the drain bolt securely.
2. Remove the oil filter, and drain the oil into a suitable container. Dispose the used oil and filter in a manner compatible with the environment.

#### NOTICE

Use an oil filter socket, rather than a strap wrench, to avoid striking and damaging the oil pressure switch.

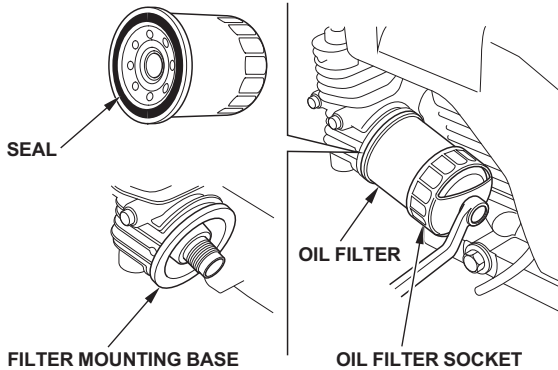

3. Clean the filter mounting base, and coat the seal of the new oil filter with clean engine oil.

#### NOTICE

Use only a Honda Genuine oil filter or a filter of equivalent quality specified for your model. Using the wrong filter, or a non-Honda filter which is not of equivalent quality, may cause engine damage.

4. Screw on the new oil filter by hand until the seal contacts the filter mounting base, then use an oil filter socket to tighten the filter an additional 3/4 turn.

Oil filter tightening torque: 12 N·m (1.2 kgf·m , 9 lbf·ft)

5. Refill the crankcase with the specified amount of the recommended oil (see page 8). Reinstall the oil filler cap and oil level dipstick.
6. Start the engine, and check for leaks.
7. Stop the engine, and check the oil level as described on page 8. If necessary, add oil to bring the oil level to the upper limit mark on the oil level dipstick.

## AIR CLEANER

A dirty air cleaner will restrict air flow to the carburetor, reducing engine performance. If you operate the engine in very dusty areas, clean the air filter more often than specified in the MAINTENANCE SCHEDULE (see page 7).

#### NOTICE

Operating the engine without an air filter, or with a damaged air filter, will allow dirt to enter the engine, causing rapid engine wear. This type of damage is not covered by the Distributor's Limited Warranty.

### Inspection

Remove the air cleaner cover and inspect the filter elements. Clean or replace dirty filter elements. Always replace damaged filter elements.

### Cleaning

1. Pull the air cleaner cover latch to the unlocked position, and remove the cover.
2. Remove the wing nut from the paper filter element.
3. Remove the paper filter element and foam filter element from the air cleaner case.
4. Remove the foam filter element from the paper filter element.

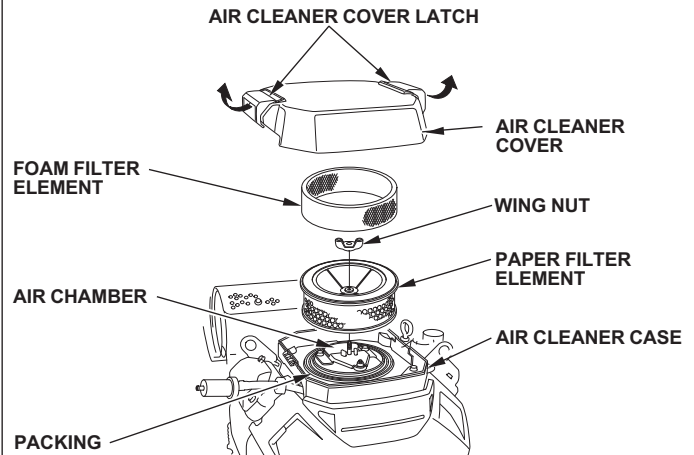

5. Inspect both filter elements, and replace them if they are damaged. Always replace the paper filter element at the scheduled interval (see page 7).

6. Clean the filter elements if they are to be reused.

Paper filter element: Tap the filter element several times on a hard surface to remove dirt, or blow compressed air [not exceeding 207 kPa (2.1 kgf/cm<sup>2</sup>, 30 psi)] through the filter element from the air cleaner case side.

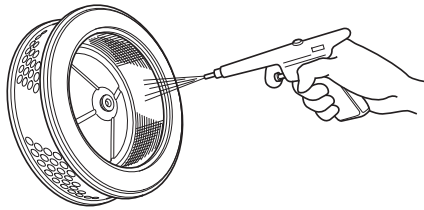

Never try to brush off dirt; brushing will force dirt into the fibers. Replace the paper filter element if it is excessively dirty.

Foam filter element: Clean in warm soapy water, rinse, and allow to dry thoroughly. Or clean in non-flammable solvent and allow to dry. Dip the filter element in clean engine oil, then squeeze out all excess oil. The engine will smoke when started if too much oil is left in the foam.

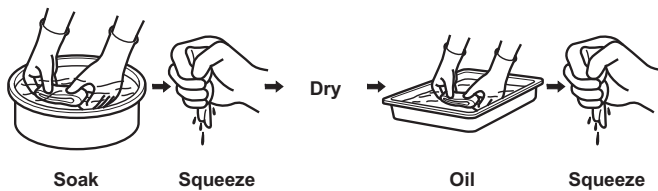

7. Wipe dirt from the inside of the air cleaner body and cover, using a moist rag. Be careful to prevent dirt from entering the air chamber that leads to the carburetor.
8. Place the foam filter element over the paper filter element, and reinstall the assembled filter element. Be sure the packing is in place beneath the filter element. Tighten the wing nut securely.
9. Lock the air cleaner cover latch securely.

**SPARK PLUG**

**Recommended Spark Plug:** ZFR5F (NGK)

The recommended spark plug has the correct heat range for normal engine operating temperatures.

**NOTICE**

*Incorrect spark plugs can cause engine damage.*

If the engine has been running, let it cool before servicing the spark plugs.

For good performance, the spark plugs must be properly gapped and free of deposits.

1. Disconnect the spark plug caps, and remove any dirt from around the spark plug area.
2. Remove the spark plugs with a 5/8-inch spark plug wrench.

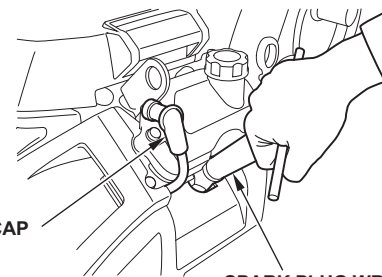

SPARK PLUG CAP

SPARK PLUG WRENCH

3. Inspect the spark plugs. Replace them if damaged, badly fouled, if the sealing washer is in poor condition, or if the electrode is worn.
4. Measure the spark plug electrode gaps with a wire-type feeler gauge. Correct the gap, if necessary, by carefully bending the side electrode. The gap should be: 0.7–0.8 mm (0.028–0.031 in)
5. Install the spark plug carefully, by hand, to avoid cross-threading.

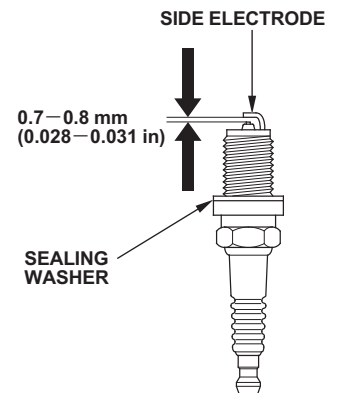

6. After the spark plug is seated, tighten with a 5/8-inch spark plug wrench to compress the sealing washer.

When installing a new spark plug, tighten 1/2 turn after the spark plug seats to compress the washer.

When reinstalling the original spark plug, tighten 1/8–1/4 turn after the spark plug seats to compress the washer.

**NOTICE**

*A loose spark plug can overheat and damage the engine. Overtightening the spark plug can damage the threads in the cylinder head.*

7. Attach the spark plug caps to the spark plugs.

**SPARK ARRESTER (applicable types)**

Your engine is not factory-equipped with a spark arrester. The spark arrester is optional part. In some areas, it is illegal to operate an engine without a spark arrester. Check local laws and regulations. A spark arrester is available from authorized Honda servicing dealers.

The spark arrester must be serviced every 100 hours to keep it functioning as designed.

If the engine has been running, the muffler will be hot. Allow it to cool before servicing the spark arrester.

**Spark Arrester Cleaning & Inspection**

1. Remove the spark arrester:

**HIGH-MOUNT MUFFLER TYPE:** Remove the special screw from the muffler and remove the spark arrester.

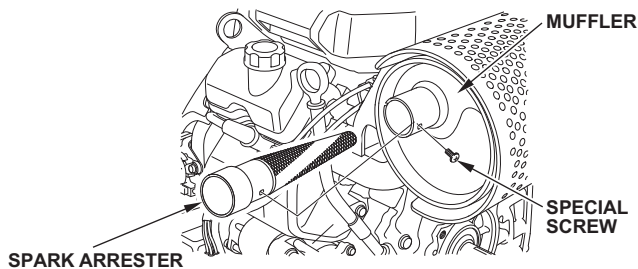

**SIDE-MOUNT MUFFLER TYPE:** Remove the 6 mm flange bolts from the muffler protector and remove the muffler protector. Remove the special screws from the spark arrester and remove the spark arrester from the muffler.

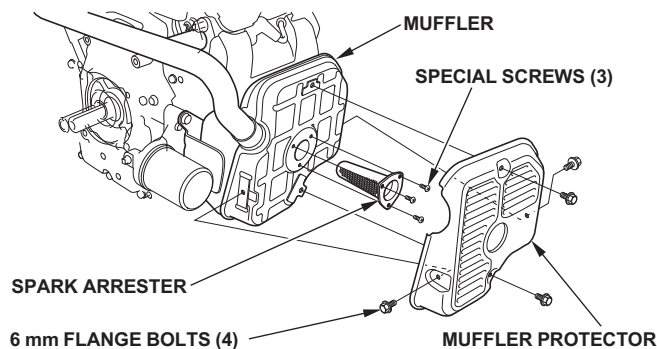

2. Use a brush to remove carbon deposits from the spark arrester screen. Be careful to avoid damaging the screen.

The spark arrester must be free of breaks and holes. Replace the spark arrester if it is damaged.

**HIGH-MOUNT MUFFLER TYPE      SIDE-MOUNT MUFFLER TYPE**

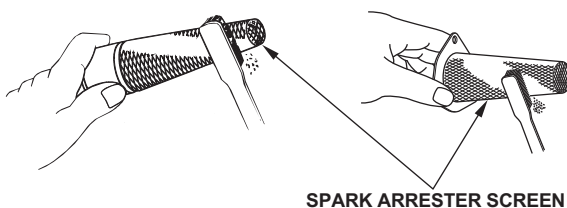

3. Install the spark arrester and muffler protector in the reverse order of disassembly.

## EVAPORATIVE EMISSIONS (CARB TIER 3)

The OEM is responsible for meeting the CARB EVAP emissions regulations for products sold in California. This regulation concerns evaporative emissions from the fuel system. See the *Emission Regulation Guide* for additional details.

Shown below is a simplified overview of required components.

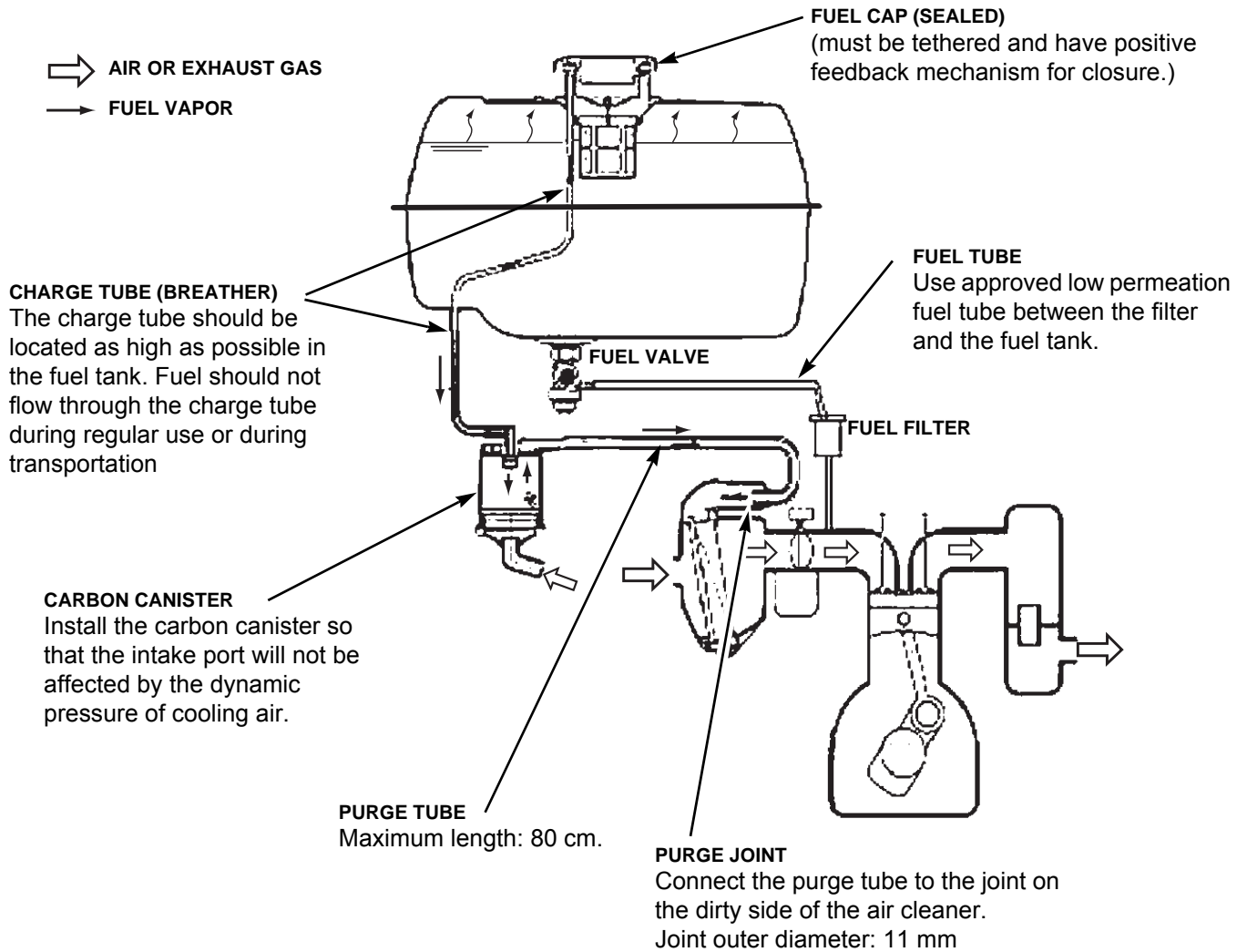

Additional information regarding manufacturers of CARB certified fuel system components can be found at: <http://www.arb.ca.gov/msprog/offroad/sore/sorecomponent/sorecomponent.htm#>.





**HONDA**

The Power of Dreams

