

# PowerLuber grease gun (lithium ion)

1880, 1882, 1882E, 1884 series "A"

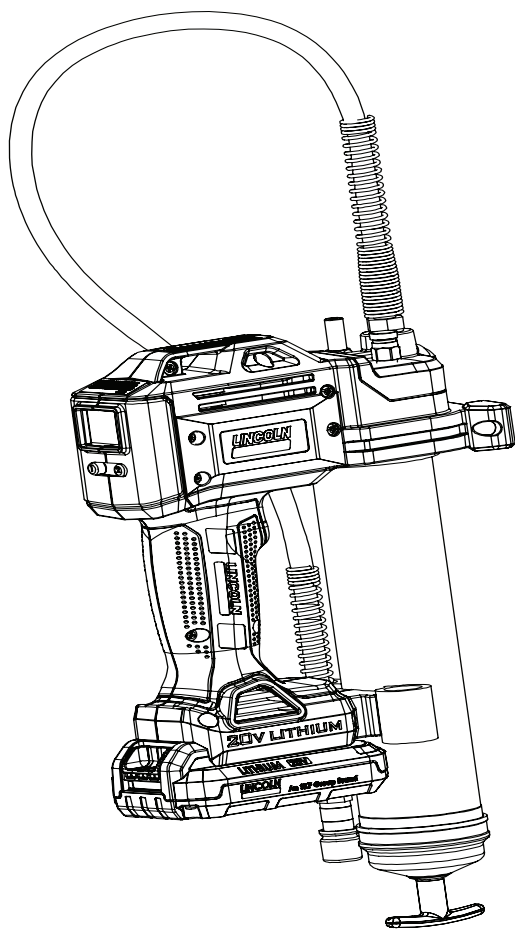

Date of issue	January 2014
Form number	423077A
Section	D7
Page	86A

**⚠ DANGER**

Read manual prior to installation or use of this product. Keep manual nearby for future reference. Failure to follow instructions and safety precautions may result in death or serious injury.

# Contents

General power tool safety warnings . . . . .	2
Specific safety . . . . .	3
Inspection . . . . .	5
Operation . . . . .	5
Charger operation . . . . .	8
Safety instruction for charger and batteries . . . . .	11
Exploded view and parts list . . . . .	13
Troubleshooting . . . . .	15

## General power tool safety warnings

 **WARNING**

Read all safety warnings and instructions. Failure to follow the warnings and instructions may result in electric shock, fire and/or serious injury.

Save all warnings and instructions for future reference.

The term “power tool” in the warnings refers to your mains-operated (corded) power tool or battery-operated (cordless) power tool.

### Work area safety

Keep work area clean and well lit.

Cluttered or dark areas invite accidents.

Do not operate power tools in explosive atmospheres, such as in the presence of flammable liquids, gases or dust. Power tools create sparks which may ignite the dust or fumes.

Keep children and bystanders away while operating a power tool.

Distractions can cause you to lose control.

### Electrical safety

Power tool plugs must match the outlet. Never modify the plug in any way. Do not use any adapter plugs with earthed (grounded) power tools. Unmodified plugs and matching outlets will reduce risk of electric shock.

Avoid body contact with earthed or grounded surfaces such as pipes, radiators, ranges and refrigerators. There is an increased risk of electric shock if your body is earthed or grounded.

Do not expose power tools to rain or wet conditions. Water entering a power tool will increase the risk of electric shock.

Do not abuse the cord. Never use the cord for carrying, pulling or unplugging the power tool. Keep cord away from heat, oil, sharp edges or moving parts. Damaged or entangled cords increase the risk of electric shock.

When operating a power tool outdoors, use an extension cord suitable for outdoor

use. Use of a cord suitable for outdoor use reduces the risk of electric shock.

If operating a power tool in a damp location is unavoidable, use a Residual Current Device (RCD) protected supply.

 **Notice**

The term “residual current device (RCD)” may be replaced by the term “ground fault circuit interrupter (GFCI)” or “earth leakage circuit breaker (ELCB)”.

### Personal safety

Use personal protective equipment.

Always wear eye protection. Protective equipment such as dust mask, non-skid safety shoes, hard hat, or hearing protection used for appropriate conditions will reduce personal injuries.

Remove any adjusting key or wrench before turning the power tool on.

### Power tool use and care

Do not force the power tool. Use the correct power tool for your application. The correct power tool will do the job better and safer at the rate for which it was designed.

Do not use the power tool if the switch does not turn it on and off. Any power tool that cannot be controlled with the switch is dangerous and must be repaired.

Disconnect the plug from the power source and/or the battery pack from the power tool before making any adjustments, changing accessories, or storing power tools.

Store idle power tools out of the reach of children and do not allow persons unfamiliar with the power tool or these instructions to operate the power tool.

Maintain power tools. Check for misalignment or binding of moving parts, breakage of parts and any other condition that may affect the power tool’s operation.

Use the power tool, accessories and tool bits in accordance with instructions.

## Battery tool use and care

Recharge only with the battery charger specified by the manufacturer.

Use power tools only with specifically designated battery packs. Use of any other battery packs may create risk of injury and fire.

When battery pack is not in use, keep it away from other metal objects, like paper clips, coins, keys, nails, screws or other small metal objects, that can make a connection from one terminal to another. Shorting the battery terminals together may cause burns or a fire.

Under abusive conditions, liquid may be ejected from the battery; avoid contact. Liquid ejected from battery may cause irritation or burns. If contact accidentally occurs, flush with water. If liquid contacts eyes, seek medical help.

## Specific safety

- Always wear eye protection. The PowerLuber can generate up to 10,000 psi (689 bar).
- Use only Lincoln 1218, 1224, 1230 or 1236 outlet whip hoses. Grease injection injuries are a very serious injury. Hold the hose only in the area of the spring guard. Avoid accidental starting. Be sure switch is not depressed when inserting battery pack.
- Replace the hose at the first sign of wear, kink or damage to the outside jacket.
- Do not bend the hose so that it becomes kinked.
- Do not overreach. Keep proper footing and balance at all times. Proper footing and balance enable better control of the tool in unexpected situations.
- Use safety equipment. Always wear eye protection.
- Dust mask, non-skid safety shoes, hard hat or hearing protection must be used for appropriate conditions.

### WARNING

Do not use any hose that has not been approved by Lincoln. Extreme pressure may cause nozzle extension or whip hose to burst.

Replace hose at first sign of wear, kinks, or damage to outside jacket.

Follow whip hose instructions and warnings. Failure to comply may result in serious injury or death.

### WARNING



To reduce the risk of injury, the user must read the instruction manual.



Separate collection. This product must not be disposed of with normal household waste.

### WARNING

Grease gun can develop high pressure up to 10,000 psi (689 bar). Use safety glasses and gloves for protection during operation. Keep hands clear of exposed rubber portion of hose.

## Service

Tool service must be performed only by qualified repair personnel. Service or maintenance performed by unqualified personnel may void warranty and result in a risk of injury.

When servicing a tool, use only identical replacement parts.

The gun uses lubricants, that may be flammable and poisonous if ingested. Do not use gun near open flame or other fire hazards.

Greases are often marketed as high temperature because it must maintain their lubricating properties in hot areas, but the lubricants may be flammable if the temperature is too high. Please read all warnings on lubricants before using this gun. Do not use flammable greases with this grease gun.

## Tool use and care

Do not use tool if switch does not turn it on or off. A tool that cannot be controlled with the switch is dangerous and must be repaired.

Do not continue to hold down trigger if grease gun is stalled. This could damage the motor or cause fire.

Disconnect battery pack from tool before making any adjustments, changing accessories, or storing the tool. Such preventive safety measures reduce the risk of starting the tool accidentally.

Store the tools out of reach of children and other untrained persons. Tools are dangerous in the hands of untrained users.

When battery pack is not in use, keep it away from other metal objects like: paper clips, coins, keys, nails, screws, or other small metal objects that can make a connection from one terminal to another. Shorting the battery terminals together may cause sparks, burns, or a fire.

Maintain tools with care. Check for misalignment or binding of moving parts, breakage of parts, and any other condition that may affect the tool's operation. If damaged, have the tool serviced before using. Many accidents are caused by poorly maintained tools.

Use only accessories that are recommended by Lincoln.

Only accessories that are capable of handling 10,000 psi (689 bar) should be used. Accessories that may be suitable for one tool may create a risk of injury when used on another tool.

## Appropriate use

The PowerLuber was exclusively designed to pump and dispense lubricant using 18 volt battery power. Do not exceed the maximum specification ratings.

### Specifications

#### Basic PowerLuber model 1880

Operating power	14.5 to 20.5 V DC
Maximum operating pressure	
Low output	6,000 psi (413 bar)
High output	6,000 psi (413 bar)
Grease reservoir capacity	14.5 oz. (411 g)
Maximum peak pressure	10,000 psi (689 bar)
Operating temperature range	0 to 120 °F (-18 to 50 °C)
Operating current	4 A at 20 to 130 °F (-6 to 54 °C)
Rated current	5 A at 20 to 130 °F (-6 to 54 °C)
Lubricant (grease)	up to NLGI #2
Grease output	
Low output (L)	3.5 oz./min. (0,103 l/min.)
High output (H)	5.5 oz./min. (0,162 l/min.)
Weight	6.5 lbs. (2,0 kg)
Accessories	
Battery li-ion	Model 1871
Output	20 V DC maximum
Capacity	1,500 mAh
Battery charger	Model 1870
Charge time	1.5 hours
Input, vac (0.6 A)	120 v, 60 hz
Outlet hose	Model 1236
Pressure rating	10,000 psi (689 bar)
Length of the hose	36 in. (914 mm)

**Note 1:** Operating current and grease output data at 1,000 psi (69 bar).

**Note 2:** The declared vibration total value has been measured in accordance with a standard test method and may be used for comparing one tool with another and the declared vibration total value may also be used in a preliminary assessment of exposure.

**Note 3:** The vibration emission during actual use of the power tool can differ from the declared total value depending on the ways in which the tool is used; and of the need to identify safety measures to protect the operator that are based on an estimation of exposure in the actual conditions of use (taking account of all parts of the operating cycle such as the times when the tool is switched off and when it is running idle in addition to the trigger time).

Models	
Sales model	Components included
1880	Grease gun with battery
1882	Grease gun with battery, charger and carrying case
1882E	Grease gun with battery, charger 230 V AC European and carrying case
1884	Grease gun with battery, extra battery, charger and carrying case.
1870E	Charger 230 V AC European
1871	Battery pack
1236	Hose, 36 in. (914 mm)
5852	Coupler, midjet hydraulic
251-10124-7	Coupler (European)

## General description

The Lincoln PowerLuber is a lithium-ion battery operated grease gun. The gun was developed for manual lubrication of grease points and includes a light emitting diode (LED) and electronic control center.

The PowerLuber is driven by a small, low voltage electric motor connected to a gear transmission. The rotary motion of the motor is converted into a reciprocating motion of the plunger using a yoke mechanism. The PowerLuber is a positive displacement single acting pump.

## Control center

Technology incorporated into the 1880 series PowerLuber includes:

- Motor protection preventing overload due to excessive current draw. The display will flash red when this occurs.
- An LCD showing battery charge, pump speed and grease output.
- An illuminating LED light to help locate grease fittings in dim light.

Fig. 1

1880 Grease gun

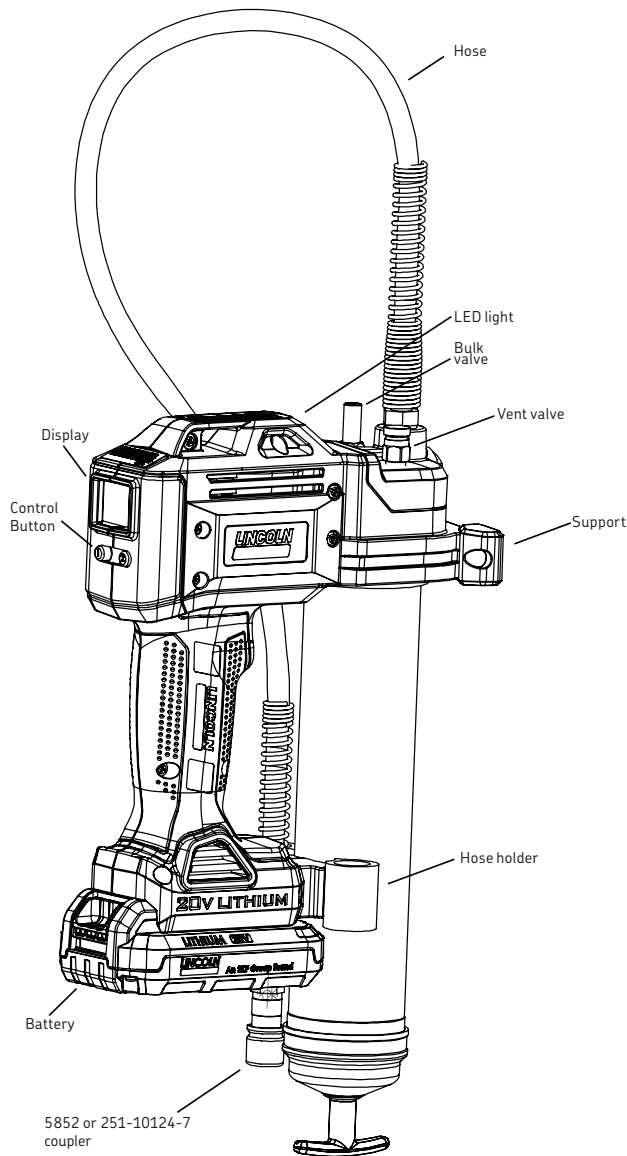

## Inspection

Visually inspect for damaged, loose or missing parts. If equipment is worn or damaged, remove from service. Contact an authorized service center for damage assessment or repair.

## Operation

### Speed selection

Pressing button 2 switches the tool between high and low pump speed. The letter "L" or "H" will be displayed on the screen.

High delivers 5.5 ounces (0,162 l) per minute at 1,000 psi (68 bar) back pressure.

Low delivers 3.5 oz. (0, 103 l) per minute at 1,000 psi (68 bar) back pressure.

High output is recommended if the tool is used to lubricate large bearings. Also, high output is recommended if tool is used to re-fill small reservoirs.

Low output is recommended if the tool is used in construction, mining applications and general lubrication.

## LCD display and LED light

- Button number 1 turns on/off the display and LED:
- The tool's trigger also turns on the display and LED:
- The LCD and display will turn off after 30 seconds if not turned off manually.

Fig. 2

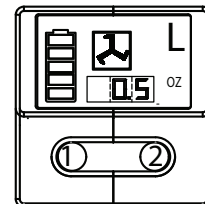

## Grease flow monitoring

- LCD shows the output of grease delivered in ounces or grams.
- Clear grease output by holding button 1 for 3 seconds.

### ! Notice

Grease meter is very accurate and does not show output if prime is lost.

**Change unit of measure to ounces or grams by holding button “1” for 15 seconds.**

## Replace grease cartridge or refill tube

- 1 Prime the PowerLuber after each refill or grease cartridge change. To prime, operate the gun until grease flows from hose. Use vent valve (→ fig.1, page 4) to expel air pockets.
- 2 Press set key 1 for 3 seconds to clear display of previous reading.

## Priming instructions

- 1 Open vent valve (→ fig.1, page 8).

### ! Notice

Always open vent valve after replacing cartridge. This will allow air to escape from cartridge and prime grease gun.

Prime the PowerLuber after each refill or grease cartridge change.

- 2 Operate the gun until grease flows from the vent valve.
- 3 Close vent valve.
- 4 Press button “1” 3 seconds to clear display of previous reading.

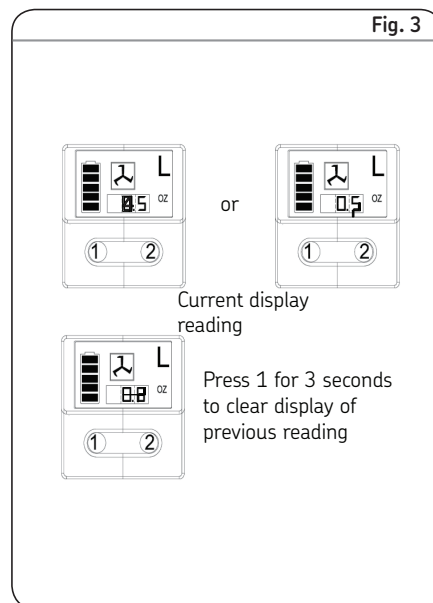

## Install grease cartridge

- 1 Unscrew the grease tube assembly from the PowerLuber.

### ! Notice

The follower seal lip must be directed toward the follower handle or rear side for cartridge loading (→ figs. 4, page 12).

To change the direction of the follower seal, unscrew tube cap from grease tube assembly and pull on the handle to remove follower seal from tube. Flip follower seal over and reassemble.

- 2 Visually check the follower seal lip direction before loading a new cartridge.
- 3 Pull back on the follower handle and latch the follower rod groove into the slot on the tube cap.
- 4 Remove the plastic cap from the grease cartridge and insert cartridge into the container tube.
- 5 Remove the pull tab from the grease cartridge and screw the grease tube assembly into the pump assembly.
- 6 Thread grease tube assembly back onto the power head.
- 7 Release follower rod from slot. Purge air from pump. Refer to page 13 for air purging instructions.
- 8 Reset display reading after purging air.
- 9 Refer to the section titled **LCD display and LED light**, page 9.

### ! Notice

Air pockets in the cartridge lubricant will cause the gun to lose its prime and will cause grease output measurements and cartridge level readings to be inaccurate.

Fig. 4

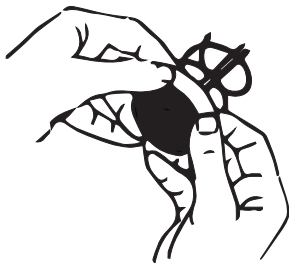

Cartridge

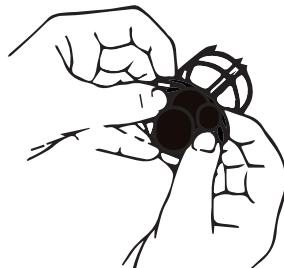

Bulk

## To fill gun from bulk container

- 1 Remove pump assembly from grease tube assembly.
- 2 Pack lubricant into cavity of the pump assembly.
- 3 Insert the open end of the grease tube assembly into lubricant. Slowly pull the follower handle back while pushing the grease tube assembly deeper into the lubricant to prevent air pockets from being pulled into the grease tube.
- 4 With the follower rod fully extended, pull it sideways to latch the rod groove into the slot in the grease tube assembly cap.
- 5 Loosely assemble the pump to the grease tube assembly. Release the follower rod from the grease tube assembly cap and disengage the follower rod from the follower by rotating the follower handle.
- 6 Push the follower rod into the grease tube assembly.
- 7 Unscrew the grease tube assembly from the pump until lubricant oozes from the interface. Tighten grease tube assembly into the pump assembly.
- 8 Reset display reading after purging air.
- 9 Refer to the section titled **LCD display and LED light**, (→ page 6).

## To fill gun with filler pump

- 1 Engage the follower rod with the follower by rotating the follower handle.
- 2 Insert the gun bulk fill valve into the filler pump socket.
- 3 Operate the filler pump to fill the container. When the follower rod groove is exposed, the grease tube assembly is filled. The follower rod will be extended approximately 20 cm (8 in.). Do not overfill!
- 4 Disengage the follower rod from the follower by rotating the follower handle.
- 5 Push the follower rod into the grease tube assembly.
- 6 Reset display reading after purging air.

### ! Notice

Remove air pocket! Air pocket at grease inlet will prevent grease from being pumped. Unscrew the vent valve three to four turns to remove small air pockets trapped in this area. If the air pocket is substantial and no grease flows from coupler after trigger is pulled for 15 seconds, refer to the following steps.

## To expel air pockets (air purging)

- 1 Withdraw the follower rod from the grease tube assembly cap and engage it with the follower by rotating the follower handle.
- 2 Unscrew the plug of vent valve 3 to 4 turns. Exert force on the follower handle until grease flows through the small hole in the side of the vent valve.
- 3 Tighten the vent valve.
- 4 Pull the trigger in short bursts to operate gun until trapped air is expelled. Disengage the follower rod from the follower by rotating the follower handle. Push the follower rod into the grease tube assembly.
- 5 If step 2 fails, unscrew the grease tube assembly 3 turns from the pump assembly.
- 6 Exert force on the follower handle until lubricant oozes from the grease tube assembly and pump assembly interface.
- 7 Retighten grease tube into the pump assembly. Disengage the follower rod from the follower by rotating the follower handle. Push the follower rod into the grease tube assembly.

## Charger operation

### Charging battery pack

Before using your PowerLuber for the first time, the battery pack should be fully charged. If the battery pack is installed in the PowerLuber, remove it and follow charging procedure below.

Lincoln chargers are designed to charge Lincoln lithium-ion batteries in 30 to 90 minutes depending on the battery's state of charge and temperature.

## Charging procedure

Make sure power circuit voltage is the same as that shown on the charger specification plate.

- 1 Plug the charger into an appropriate outlet before inserting battery pack.
- 2 Insert the battery pack into the charger. The green (charging) light will blink continuously indicating that the charging process has started.
- 3 The completion of charge will be indicated by the green light remaining on continuously. The pack is fully charged and may be used at this time.
- 4 Disconnect charger from power source when not in use.

### CAUTION

Do not probe with conductive objects. 120/230 V AC present at charging terminals. Failure to comply may result in death or personal injury.

### Indicator light operation

- The charge is complete (solid green).
- - - - Battery is charging (flashing green).
- Red, at a fast rate. Replace battery.
- •••• - Charger detected a weak or damaged battery. Stop charging battery. Hot/cold pack delay. Charger detected a battery that is excessively hot or cold. It automatically starts a hot/cold pack delay, suspending charging until temperature of battery has normalized. After this, charger automatically switches to battery charging mode.

### Notice

Battery temperature will increase during and shortly after use. Batteries may not accept a full charge if they are charged immediately after use. Allow the battery pack to cool to room temperature before charging for best results.

### Notice

Vent slots in top and bottom of charger must not be obstructed.

Do not charge battery when temperature is below 5 °C (40 °F) or above 40 °C (104 °F).

## Important charging Notices

Longest life and best performance can be obtained if the battery is charged when the air temperature is between 18 and 24 °C (65 and 75 °F). Do not charge the battery in an air temperature below 5 °C (40 °F) or above 41 °C (105 °F). This is important and will prevent serious damage to the battery.

- 1 The charger and battery may become warm to the touch while charging. This is a normal condition, and does not indicate a problem.
- 2 If the battery does not charge properly:
  - 2.1 Check current at receptacle by plugging in a lamp or other appliance.
  - 2.2 Check to see if the receptacle is connected to a light switch which turns power off when you turn out the lights.
  - 2.3 Move charger and battery to a location where the surrounding air temperature is between approximately 18 to 24 °C (65 to 75 °F).
  - 2.4 If charging problems persist, take the tool, battery and charger to your local service center.
- 3 The battery should be recharged when it fails to produce sufficient power on jobs. Do not continue to use under these conditions. Follow the charging procedure. You may also charge a partially used pack whenever you desire with no adverse affect on the battery.

- 4 Under certain conditions, with the charger plugged into the power supply, the exposed charging contacts of the charger can be shorted by foreign material. Foreign materials of a conductive nature such as, but not limited to, steel wool, aluminium foil, or any buildup of metallic particles should be kept away from charger cavities. Always unplug the charger from the power supply when there is no battery in the cavity. Unplug charger before attempting to clean.
- 5 Do not freeze or immerse charger in water or any other liquid.

### WARNING

Do not allow any liquid to get inside charger. Electric shock may result.

To facilitate cooling of battery pack after use, avoid placing charger or battery pack in a warm environment such as a metal shed or an un-insulated trailer.

Failure to comply may result in serious injury or death.

# Safety instructions for charger and batteries

## Save these instructions

This manual contains important safety and operating instruction for the Lincoln model 1870E battery charger.

### DANGER

Do not probe with conductive objects.  
Do not charge damaged battery.  
Risk of Electric Shock 120 V AC or 230 V AC present at charger terminals.  
Replace immediately.  
Failure to comply may result in serious injury or death.

### DANGER

Do not expose battery to spark or flame. Battery liquid may burn.

Do not splash or immerse in water or other liquids. This may cause premature cell failure.

Failure to comply may result in serious injury or death.

- Do not store or use the tool and battery in locations where the temperature may reach or exceed 40 °C (105 °F) such as outside sheds or metal buildings in the summer.

- 1 Before using a battery charger, read all instructions and cautionary markings on battery charger, battery pack, and product using battery.

### CAUTION

Do not charge Lincoln model 1871 battery packs with any other charger.

To reduce risk of injury, Lincoln model 1870 or 1870E chargers should only be used to charge Lincoln battery pack model 1871. Other types of batteries may burst.

Failure to comply may result in serious personal injury

## Read all instructions

- Do not incinerate the battery pack even if it is severely damaged or is completely worn out. The battery pack can explode in a fire. Toxic fumes and materials are created when lithium ion battery packs are burned.
- Do not charge or use battery in explosive atmospheres, such as in the presence of flammable liquids, gases or dust. Inserting or removing the battery from the charger may ignite the dust or fumes.
- If battery contents come into contact with the skin, immediately wash area with mild soap and water. If battery liquid gets into the eye, rinse water over the open eye for 15 minutes or until irritation stops. If medical attention is needed, the battery electrolyte for lithium-ion batteries is composed of a mixture of liquid organic carbonates and lithium salts.
- Contents of opened battery cells may cause respiratory irritation. Provide fresh air. If symptoms persists, see a doctor for treatment.

### DANGER

Never attempt to open the battery pack for any reason. If the plastic housing of the battery pack breaks or cracks, return to a service center for recycling. Failure to comply may result in serious injury or death.

- 2 Do not expose charger to rain, snow or frost.
- 3 Do not abuse cord. Never carry charger by cord or pull on it to disconnect from receptacle. Pull by plug rather than cord when disconnecting charger. Have damaged or worn power cord and strain reliever replaced immediately. Do not attempt to repair power cord.
- 4 Make sure cord is located so that it will not be stepped on, tripped over, or otherwise subjected to damage or stress.
- 5 Do not use an extension cord unless absolutely necessary. Use of improper extension cord could result in a risk of fire and electric shock.
- 6 Do not operate charger with damaged cord or plug. Replace immediately, to avoid a hazard. Do not attempt to repair power cord.
- 7 Do not operate charger if it has received a sharp blow, been dropped, or otherwise damaged in any way, take it to a qualified service center.

- 8** Do not disassemble charger or battery pack. Take it to a qualified service centre when service or repair is required. Incorrect reassembly may result in risk of electrical shock or fire.
- 9** Unplug charger from outlet before attempting any cleaning to reduce risk of electric shock.
- 10** Charge the battery pack in a well ventilated place; do not cover the charger and battery with anything while charging.
- 11** Do not store the charger or battery packs in locations where the temperature may reach or exceed 122 °F (50 °C) such as a metal tool shed, or a car in the summer which can lead to deterioration of the storage battery.
- 12** Do not charge battery pack when the temperature is below 40 °F (5 °C) or above 105 °F (40 °C). This is very important for proper operation.
- 13** Do not incinerate battery pack. It can explode in a fire.
- 14** Do not charge battery in damp or wet locations.
- 15** Do not attempt to charge any other cordless tool or battery pack with the Lincoln model 1870 series charger.
- 16** Do not short across the terminals of the battery pack. Extremely high temperatures could cause personal injury or fire.
- 17** This appliance is not intended for use by persons (including children) with reduced physical, sensory or mental capabilities, or lack of experience and knowledge.
- 18** Dispose of expended batteries properly. The Lincoln model 1871 battery pack contains rechargeable, lithium-ion batteries. These batteries must be recycled or disposed of properly. Drop off expended battery packs at your local replacement battery retailer, or your recycling centre.

Fig. 6

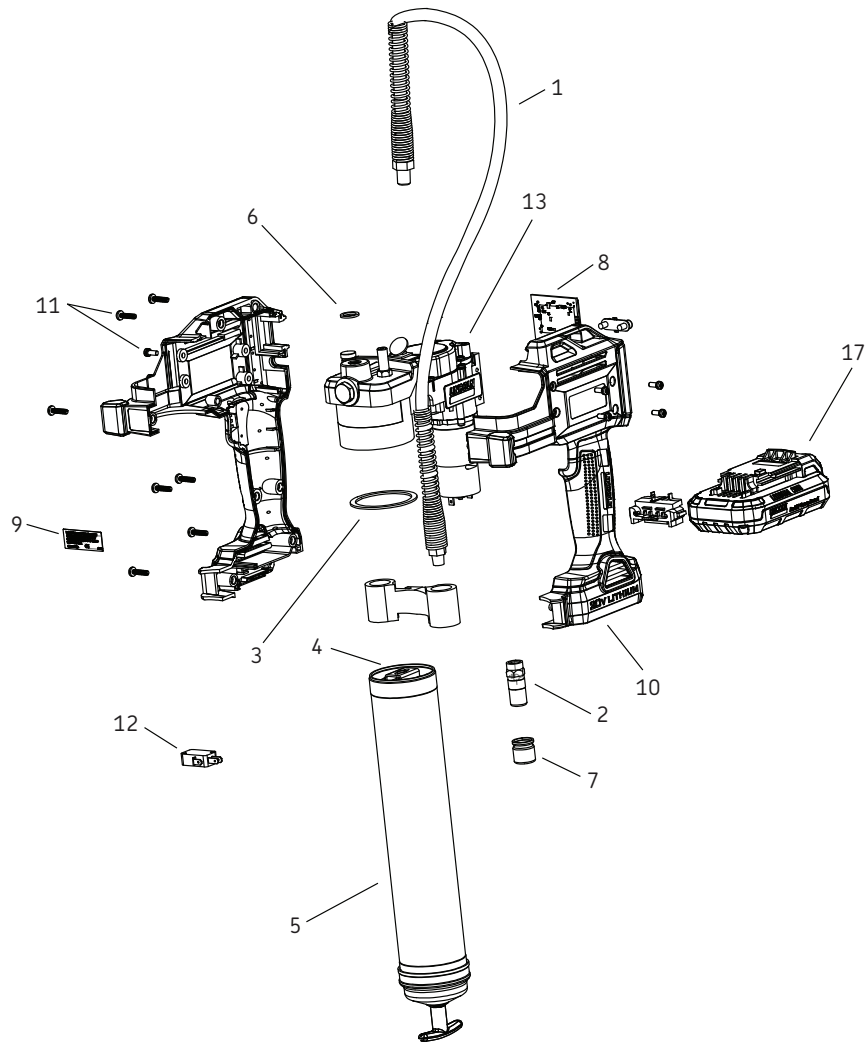

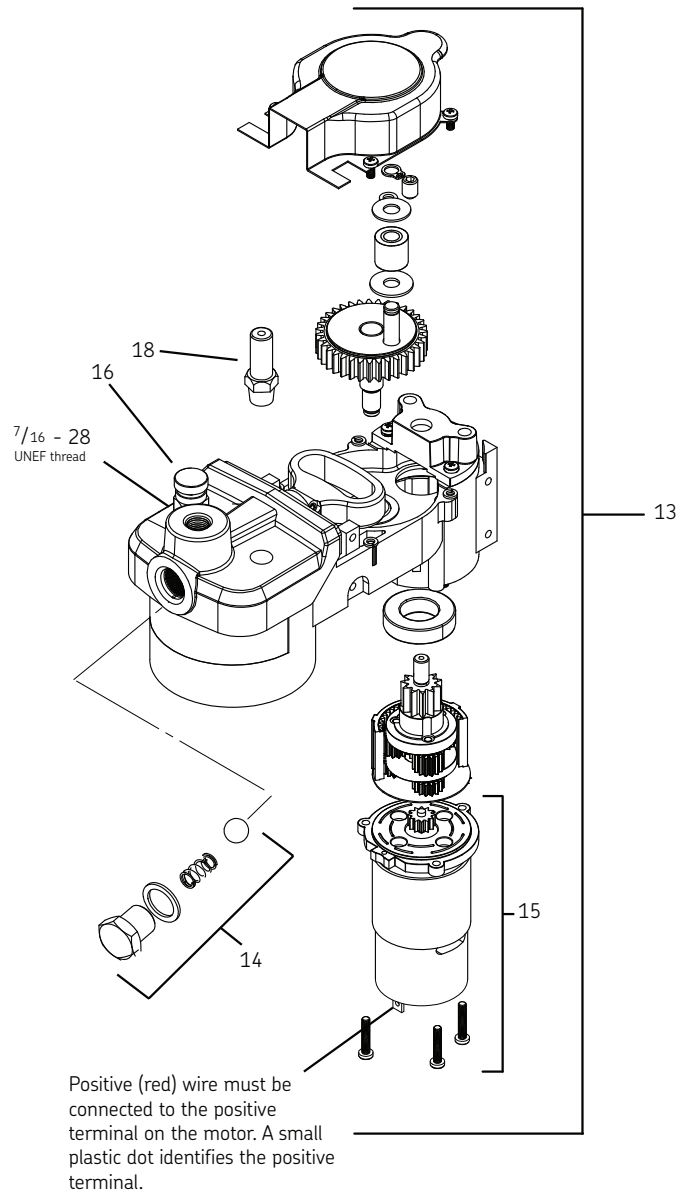

**Service parts list**

Item	Description	Part number
1	Flexible hose 36 in.(914 mm) with gasket	1236
2	Coupler (model 1880)	5852
	Coupler (model 1880E)	251-10124-7
3	Packing	34793
4	Follower assembly kit	272072
5	Grease tube assembly	271882
6	Gasket kit (hose)	271884
7	Coupler cap kit	286093
8	Electrical components kit	280067
9	Decal kit	280068
10	Handle with electrical component kit	280069
11	Handle with screw kit	280070
12	Switch kit	280071
13	Pump assembly kit	280072
14	Check valve kit	280073
15	Motor with adapter kit	280074
16	Vent valve kit	286315
17	Battery 18 V (lithium)	1871
18	Filler nipple	91108
Not shown	Charger (lithium)	1870
Not shown	Strap	1414
Not shown	Case kit	280085

## Troubleshooting

Condition	Possible cause	Corrective action
Motor fails to run.	Battery needs charging.	Recharge battery.
	Faulty wiring to motor.	Remove battery, disassemble handle and check wiring for loose connection.
PowerLuber fails to dispense grease.	Grease tube assembly is out of grease.	Check that grease tube assembly has grease.
	Loss of prime.	Repeat priming operation.
	Ball check (14) is not functioning.	Remove ball check (14), clean and inspect ball seat area.
PowerLuber continues to lose prime.	Air may be trapped in several locations in container after bulk filling.	Empty grease tube assembly, refill and repeat priming instructions.
	Follower may be binding in grease tube assembly.	Replace grease tube assembly (5). Disassemble grease tube assembly and clean. Be sure that follower has properly entered the grease cartridge. or Verify that the follower is not caught on the rim of the grease cartridge.
	Check ball seat and check ball dirty.	Clean check ball and check ball seat.
Battery fails to take a charge.	Charger may not have power.	Check that receptacle has power.
	Battery may be bad.	Replace battery.

Declaration of Conformity as defined by Machinery Directive 2006/42/EC.  
The manufacturer Lincoln Industrial, hereby declares that the model of the PowerLuber Grease Gun in the version supplied by us complies with the provision of the above mentioned directive.

Complies with the following EC-Directives and standards  
2006/42/EC, 2009/98/EC, 2004/108EC, 2006/66/E, EN ISO 12100:2011, EN 55014-1, EN 55014-2, EN 61000-7, EN 60745-1

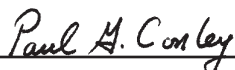
  
\_\_\_\_\_

St. Louis, MO January 2014 Paul Conley,  
Chief Engineer

# Lincoln industrial standard warranty

## Standard limited warranty

Lincoln warrants the equipment manufactured and supplied by Lincoln to be free from defects in material and workmanship for a period of one (1) year following the date of purchase, excluding there from any special, extended, or limited warranty published by Lincoln. If equipment is determined to be defective during this warranty period, it will be repaired or replaced, within Lincoln's sole discretion, without charge.

This warranty is conditioned upon the determination of a Lincoln authorized representative that the equipment is defective. To obtain repair or replacement, you must ship the equipment, transportation charges prepaid, with proof of purchase to a Lincoln Authorized Warranty and Service Center within the warranty period.

This warranty is extended to the original retail purchaser only. This warranty does not apply to equipment damaged from accident, overload, abuse, misuse, negligence, faulty installation or abrasive or corrosive material, equipment that has been altered, or equipment repaired by anyone not authorized by Lincoln. This warranty applies only to equipment installed, operated and maintained in strict accordance with the written specifications and recommendations provided by Lincoln or its authorized field personnel.

**This warranty is exclusive and is in lieu of any other warranties, express or implied, including, but not limited to, the warranty of merchantability or warranty of fitness for a particular purpose. Warranty on items sold by Lincoln, but not manufactured by Lincoln are subject to the warranty consideration, if any, of their manufacturer (such as hoses, hydraulic and electric motors, electrical controllers, etc.) Assistance in making such warranty claims can be offered as required.**

In no event shall Lincoln be liable for incidental or consequential damages. Lincoln's liability for any claim for loss or damages arising out of the sale, resale or use of any Lincoln equipment shall in no event exceed the purchase price. Some jurisdictions do not allow the exclusion or limitation of incidental or consequential damages, therefore the above limitation or exclusion may not apply to you.

This warranty gives you specific legal rights. You may also have other rights that vary by jurisdiction.

Customers not located in the Western Hemisphere or East Asia: Please contact Lincoln GmbH and Co. Kg, Walldorf, Germany, for your warranty rights.

## Special limited warranties

### Special limited 2 year warranty SL-V series, single injectors – 85772, 85782, and replacement injectors – 85771, 85781

Lincoln warrants the SL-V Injector series to be free from defects in material and workmanship for two (2) years following the date of purchase. If an injector model (single or replacement) is determined to be defective by Lincoln, in its sole discretion, during this warranty period, it will be repaired or replaced, at Lincoln's discretion, without charge.

### Special limited 5 year warranty series 20, 25, 40 bare pumps, pmv bare pumps, heavy duty and 94000 series bare reels

Lincoln warrants series 20, 25, 40 bare pumps, PMV bare pumps, heavy duty (82206), mini bench (81133, 81323), and all 94000 LFR series (single arm and dual arm) bare reels to be free from defects in material and workmanship for five (5) years following the date of purchase. If equipment is determined by Lincoln, in its sole discretion, to be defective during the first year of the warranty period, it will be repaired or replaced at Lincoln's discretion, without charge. In years two (2) and three (3), the warranty on this equipment is limited to repair with Lincoln paying parts and labor only. In years four (4) and five (5), the warranty on this equipment is limited to repair with Lincoln paying for parts only.

### Special limited 5 year warranty limited oil meters, limited fluid control valves, aod (air-operated diaphragm pumps)

Lincoln warrants the 712 series control valves, 912 series lube meters, electronic lube meters (980, 981, 982 series), our universal inline digital meters (812/813 series), and our AOD pump offering to be free from defects in material and workmanship for five (5) years following the date of purchase. If either is determined to be defective by Lincoln, in its sole discretion, during the warranty period, they will be repaired or replaced, at Lincoln's discretion, without charge.

### Special DEF (diesel exhaust fluid) limited warranty

DEF products are warranted to be free from defects in material and workmanship for a period of one (1) year following the date of purchase. The following exceptions to the standard warranty period are in effect:

- **85700-30/85700-50 DEF hose reels (bare reel only),** 277251/277252 AC DEF pumps, and 277256 and 277257 DEF meters are warranted for two (2) years from date of purchase.
- **85623 DEF AOD (air operated diaphragm) pumps** are covered under the standard five (5) year AOD pump warranty.

If either is determined to be defective by Lincoln, in its sole discretion, during the warranty period, they will be repaired or replaced, at Lincoln's discretion, without charge.

### Lincoln Industrial contact information

To find Lincoln Industrial's nearest service center call the following number; customer service 314-679-4200 (international number 01-314-679-4200) or you may also use our website [www.lincolnindustrial.com](http://www.lincolnindustrial.com)

This page left intentionally blank

This page left intentionally blank

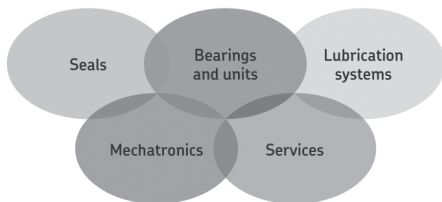

### The Power of Knowledge Engineering

Combining products, people, and application-specific knowledge, SKF delivers innovative solutions to equipment manufacturers and production facilities in every major industry worldwide. Having expertise in multiple competence areas supports SKF Life Cycle Management, a proven approach to improving equipment reliability, optimizing operational and energy efficiency and reducing total cost of ownership.

These competence areas include bearings and units, seals, lubrication systems, mechatronics, and a wide range of services, from 3-D computer modelling to cloud-based condition monitoring and asset management services.

SKF's global footprint provides SKF customers with uniform quality standards and worldwide product availability. Our local presence provides direct access to the experience, knowledge and ingenuity of SKF people.

© SKF is a registered trademark of the SKF Group.

© Lincoln is a registered trademark of Lincoln Industrial Corp.

© SKF Group 2014

The contents of this publication are the copyright of the publisher and may not be reproduced (even extracts) unless prior written permission is granted. Every care has been taken to ensure the accuracy of the information contained in this publication but no liability can be accepted for any loss or damage whether direct, indirect or consequential arising out of the use of the information contained herein.

SKF PUB LS/14 14386 EN · January 2014 · Form 423077A

**LINCOLN**

**SKF**