

Table of Contents:

Specifications and Dimensions:

BTL09A120C	3
BTL14A240C	4
BTL18A300C/BTL24A360C/BTL35A480C	5

Safety and Installation Instructions:

English	6
French	10
Spanish	14

Cross Reference:

BTL09A120C	18
BTL14A240C	18
BTL18A300C/BTL24A360C/BTL35A480C	20

Application Guide:

Motorcycles	22
ATVs	45
Scooters	50
UTVs	53
PWCs	53

Frequently Asked Questions	55
---	-----------

LITHIUM IRON PHOSPHATE BATTERY (LiFePO4) Specifications and Dimensions

Case size #1, 4.21" (107mm) length

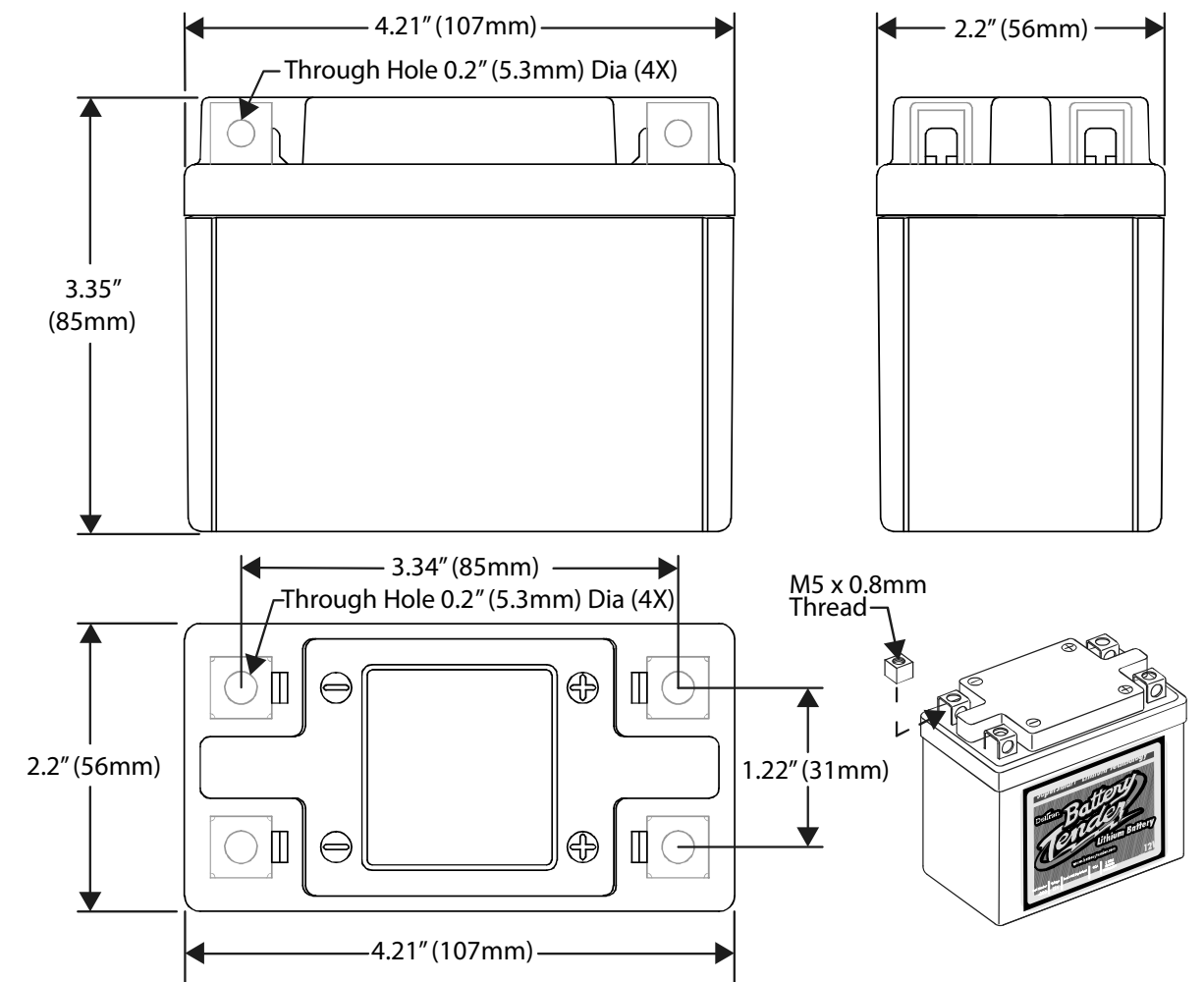

Part #	Voltage	Lead acid equivalent Ah	Lithium Ah	CCA	Weight (Kg)	Weight (Lbs)	Max charger Rate (A)
BTL09A120C	12V	7-9	2	120	0.50	1.2	10

Case size #2, 5.27" (134mm) length

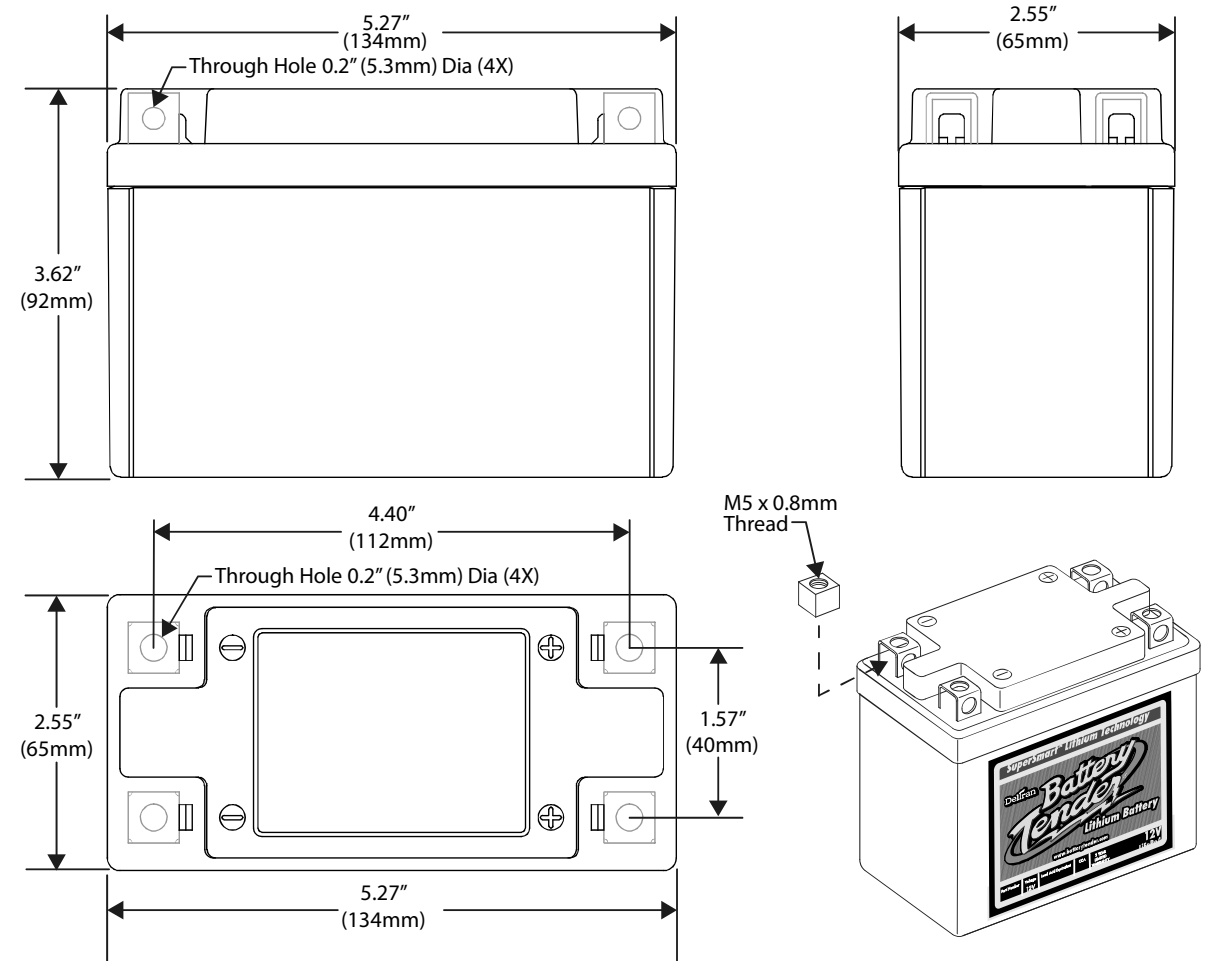

Part #	Voltage	Lead acid equivalent Ah	Lithium Ah	CCA	Weight (Kg)	Weight (Lbs)	Max charger Rate (A)
BTL14A240C	12V	10-14	4	240	0.8	1.76	10

Case size #3, 6.49" (165mm) length

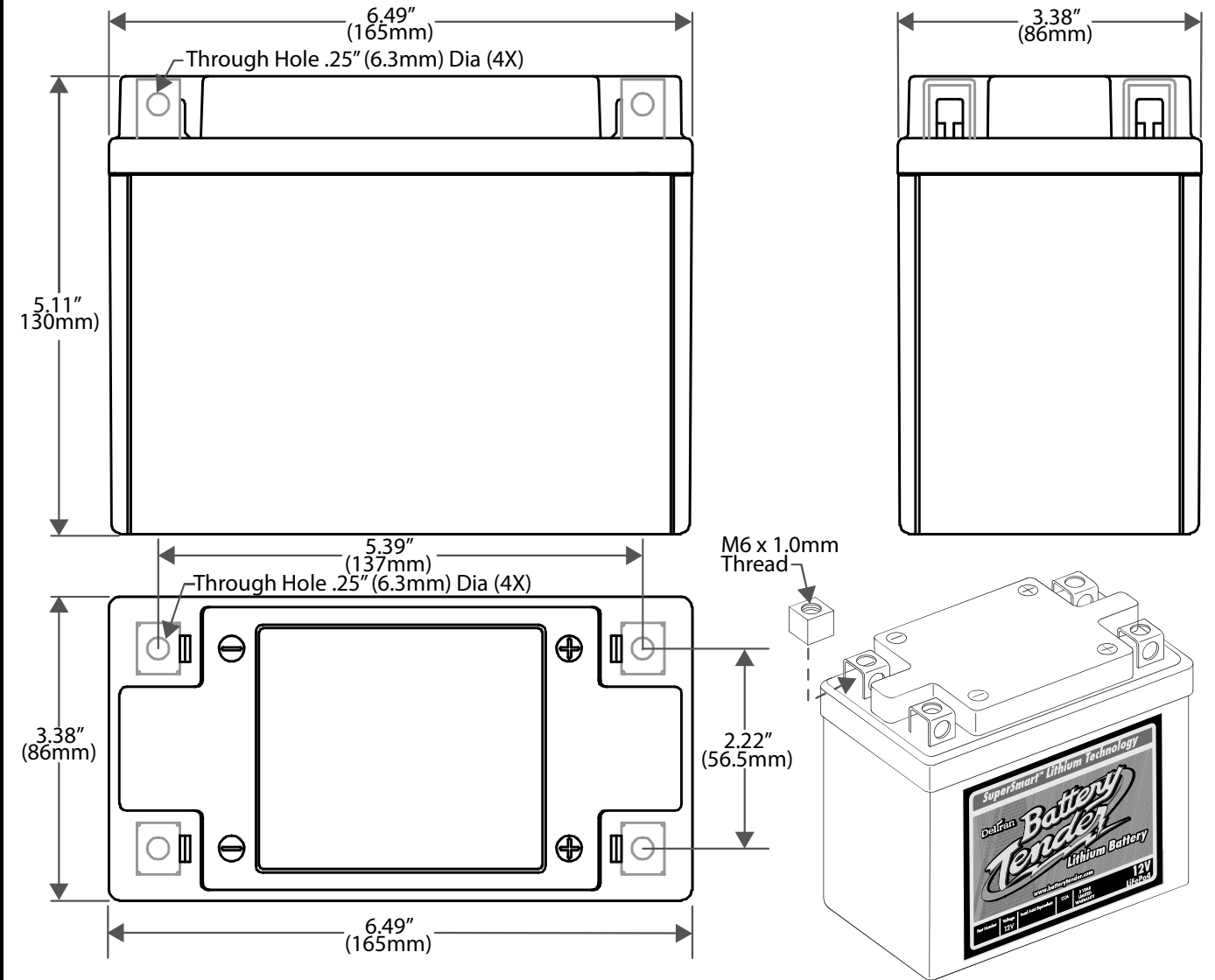

Part #	Voltage	Lead acid equivalent Ah	Lithium Ah	CCA	Weight (Kg)	Weight (Lbs)	Max charger Rate (A)
BTL18A300C	12V	16-18	5	300	0.95	2.1	10
BTL24A360C	12V	21-24	6	360	1.2	2.6	10
BTL35A480C	12V	26-35	8	480	1.7	3.75	10

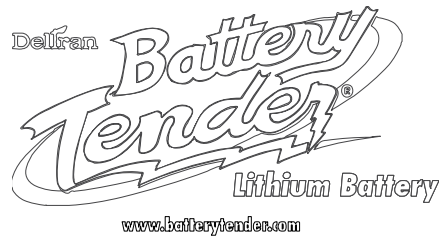

Deltran Battery Tender[®]
LITHIUM IRON PHOSPHATE BATTERY

IMPORTANT SAFETY INSTRUCTIONS

- 1) SAVE THESE INSTRUCTIONS
- 2) Do not throw away the box or any foam packing until after the installation is complete.

CAUTIONS

- a) Do not immerse in water.
- b) Do not short terminals together.
- c) Do not use or store the battery near sources of fire or heat.
- d) Do not reverse the positive (+) or negative (-) terminals.
- e) Do not put the battery into a fire or apply direct heat to it.
- f) Do not pierce the battery casing.
- g) Do not strike, throw, or subject the battery to severe physical shock.
- h) Do not solder directly to the battery terminals.
- i) Do not attempt to modify the battery in any way.
- j) Do not place the battery in a microwave oven or pressurized container.
- k) Do not use the battery if it gives off an odor or generates heat.
- l) Do not allow charge voltage in excess of 14.8Volts.
- m) DO NOT use the battery in temperatures below -10°C (14°F).
- n) Do NOT use lead-acid chargers which employ a high-voltage “anti-sulfation” routine.
- o) Keep batteries away from pets and children.
- p) Fully discharge before disposal.

WARNING

- a) Be extra cautious to reduce risk of dropping a metal tool onto battery. It might spark or short-circuit battery or other electrical parts that may cause explosion.
- b) Remove personal metal items such as rings, bracelets, necklaces, and watches when working with any battery. A battery can produce a short-circuit current high enough to weld a ring or the like to metal, causing a severe burn.
- c) To reduce risk of battery explosion, follow these instructions and those published by the manufacturer of any equipment you intend to use in vicinity of this battery. Review cautionary markings on these products and on engine.

INSTALLATION INSTRUCTIONS

- a) Carefully remove the existing lead-acid battery from your vehicle following the manufacturer’s guidelines.
- b) Next place the original battery next to your Battery Tender[®] Lithium battery to compare the variation in size. The original battery may be the same width but is longer in length and taller in height. To make up the difference apply the appropriate amount of the adhesive foam to either the Lithium battery or the battery box.

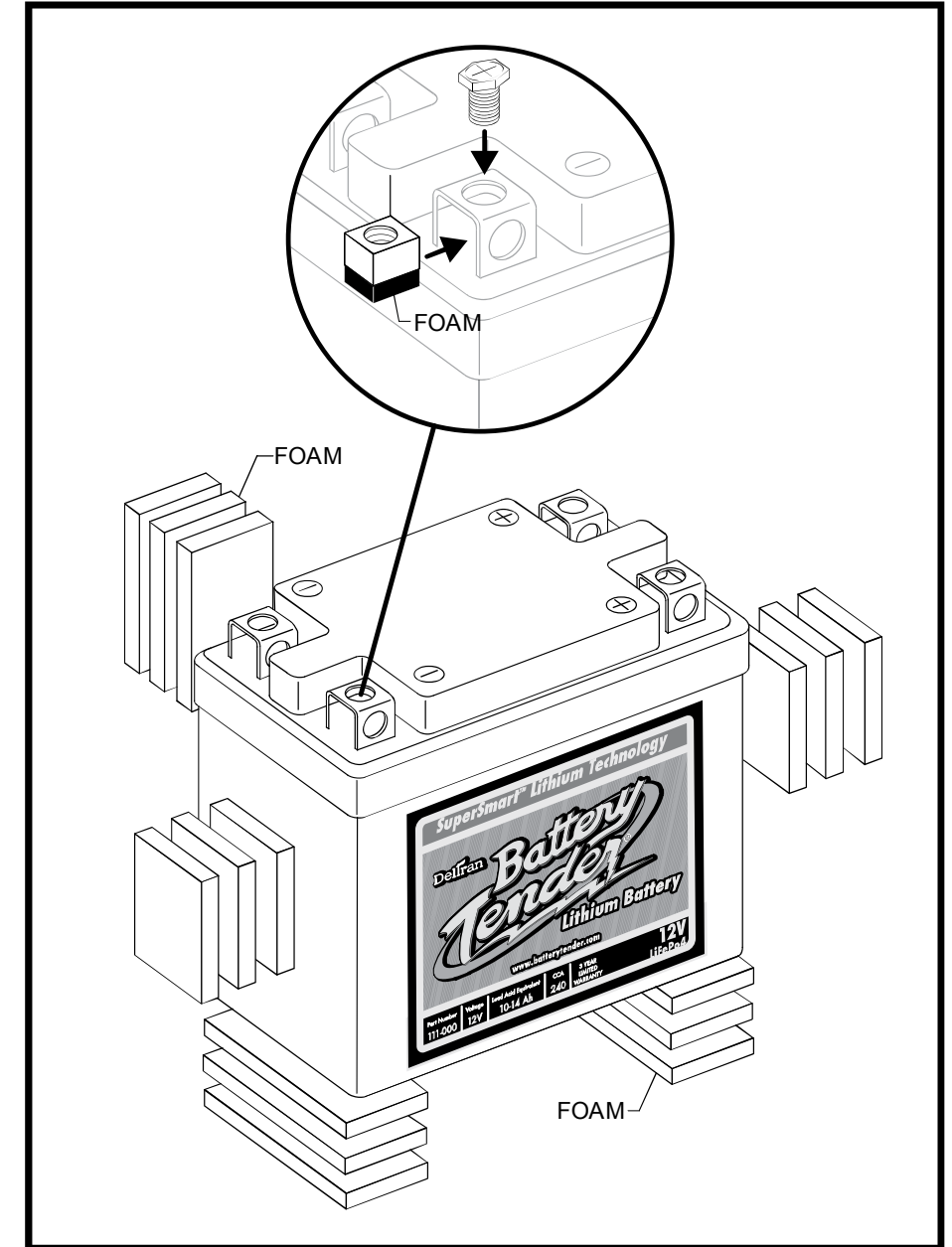

- c) Ensure the battery now fits securely in the battery box and allows the battery cables to reach the battery terminals with no issues.
- d) The Battery Tender[®] Lithium battery allows the cable eyelets to be either connected from the top or front side of the terminals. Choose the side that matches your configuration the best.
- e) Use the supplied hardware to attach the terminal rings to your battery. Do not over-tighten the screws. (See diagram above)

- f) Once installed apply a good quality anti-corrosion spray to the terminals.
- g) Reinstall the vehicles protective battery caps, and cover the unused terminals with the supplied caps to ensure the battery cannot short against any part of the vehicle.
- h) Battery Tender® Lithium batteries are pre-charged to 70% of capacity and must be charged before use.

USAGE

- a) There are a couple of damaging conditions for any Lithium starter battery; they include prolonged storage in high temperatures and allowing the battery to be deeply discharged.
- b) Compared to lead-acid batteries, the Battery Tender® Lithium battery has less than 5% of the average self-discharge rate and can be stored for much longer periods without maintenance.
- c) If there is no current draw from your vehicle when your ignition is off the Battery Tender® Lithium battery can be stored for one year without damage.
- d) For long term storage the ideal temperature is 1°C (34°F).
- e) The battery should be stored in a minimum charge state of 70%.
- f) DO NOT use the battery in temperatures below -10°C (14°F).

CHARGING

- a) Do not use a desulphation or pulse charger. Doing so will damage the battery and void the warranty.
- b) Standard lead-acid chargers may be used, as long as they do not exceed 14.8Volts during charging.
- c) Maximum charge rate is 10Amps.
- d) It is strongly recommended to use a lithium specific charger such as the units in the Battery Tender® Lithium Charger series.
- e) Do not allow the lithium battery to discharge below 8Volts as this will damage the battery and void the warranty.
- f) Do not charge the battery in temperatures below -10°C (14°F).

WARRANTY (North America)

Warranty

- a) Deltran Battery Tender® offers a Limited Three-Year Warranty for its Lithium Batteries, for defects in material and or workmanship.
- b) Do NOT return any product without an RMA# (Return Merchandise Authorization) or before first contacting Deltran Battery Tender® to perform some simple diagnostics. In many cases issues can be resolved prior to return.
- c) Check our website www.batterytender.com for the latest updated warranty information.
- d) Warranty is not transferable from original purchaser.

Warranty Periods

- 1) 0-12 months: Replace free of charge with original receipt or product registration on our website.
- 2) 13-24 months: 50% off MSRP with original receipt or registered on website.
- 3) 25-36 months: 35% off MSRP with original receipt or registered on website.
- * Customers are responsible for paying the initial shipping charge to return the batteries. Deltran will pay shipping on replacement batteries returned to customers, except those without a copy of the receipt and/or RMA#.

Returns MUST be accompanied by:

- a) A copy of the Original Receipt unless the battery was registered on our website.
- b) Deltran Battery Tender® RMA#.

Returns without a receipt

- a) If there is no receipt but we can determine from the serial code that the battery is still in the warranty period, or within the first three years of Deltran selling the battery then the customer receives 35% off MSRP for that battery type.
- b) The customer is responsible for all shipping charges.

No Fault Found

- a) Any product found NOT defective after testing in house at Deltran will only be returned to customers at their expense for shipping.

Conditions Not Covered

- a) Any physical damage to the battery occurring after purchase.
- b) Any modifications to the battery, including but not limited to the terminals.
- c) Any corrosion including salt water.
- d) Any over-voltage charging of the battery.
- e) Battery discharged below 8Volts.
- f) Purchased from an unauthorized source.

Shipping Damage

- a) Any item damaged in transit must be reported to the Shipper Immediately upon opening the package.
- b) Also notify Deltran of the situation.
- c) All original packing must be retained until further notice.
- d) Deltran will respond with further instructions.

CONSIGNES DE SÉCURITÉ IMPORTANTES

- 1) CONSERVEZ CES INSTRUCTIONS
- 2) Ne jetez pas la boîte ou tout autre emballage en mousse jusqu'à la fin de l'installation

MISES EN GARDE

- a) N'immergez pas dans l'eau.
- b) Ne court-circuitez pas ensemble les bornes.
- c) N'utilisez pas ou ne rangez pas la batterie près d'une source de feu ou d'un radiateur.
- d) N'inversez pas la borne positive (+) ou la borne négative (-).
- e) Ne mettez pas la batterie au feu ou ne la soumettez pas à une chaleur directe.
- f) Ne percez pas le boîtier de la batterie.
- g) Ne frappez pas la batterie, ne la lancez pas, ou ne la soumettez pas à des chocs physiques importants.
- h) Ne soudez rien directement aux bornes de la batterie.
- i) Ne tentez pas de modifier la batterie en aucune façon.
- j) Ne placez pas la batterie dans un four à micro-ondes ou un conteneur pressurisé.
- k) N'utilisez pas la batterie si elle dégage une odeur ou génère de la chaleur.
- l) Ne laissez pas la tension de charge monter au-delà de 14,8 V.
- m) N'utilisez PAS la batterie à des températures inférieures à -10 °C (14 °F).
- n) N'utilisez PAS des chargeurs pour batterie au plomb-acide qui utilisent une routine « antisulfatation » à haute tension.
- o) Gardez les batteries hors de portée des animaux et des enfants.
- p) Déchargez-la complètement avant de la jeter.

AVERTISSEMENT

- a) Faites preuve d'une grande prudence pour réduire le risque de laisser tomber un objet métallique sur la batterie. Cela pourrait créer des étincelles ou court-circuiter la batterie ou d'autres composants électriques, ce qui risque de provoquer une explosion.
- b) Retirez les objets personnels en métal tels que les bagues, bracelets, colliers et montres lorsque vous travaillez avec une batterie. Une batterie peut produire un court-circuit suffisamment élevé pour souder à du métal une bague ou un autre objet semblable, causant des brûlures graves.
- c) Pour réduire les risques d'explosion de la batterie, suivez ces instructions et celles publiées par le fabricant de tout équipement que vous avez l'intention d'utiliser à proximité de cette batterie. Passez en revue les mises en garde concernant ces produits et le moteur.

INSTRUCTIONS D'INSTALLATION

- a) Retirez avec soin la batterie au plomb-acide actuelle de votre véhicule en suivant les directives du fabricant.
- b) Placez ensuite la batterie d'origine à côté de votre batterie au lithium Battery Tender^{MD} pour comparer les différences de leurs dimensions. La batterie d'origine peut être de même largeur mais plus longue et plus haute. Pour compenser la différence, ajoutez la quantité appropriée de mousse adhésive à la batterie au lithium ou au boîtier de la batterie.

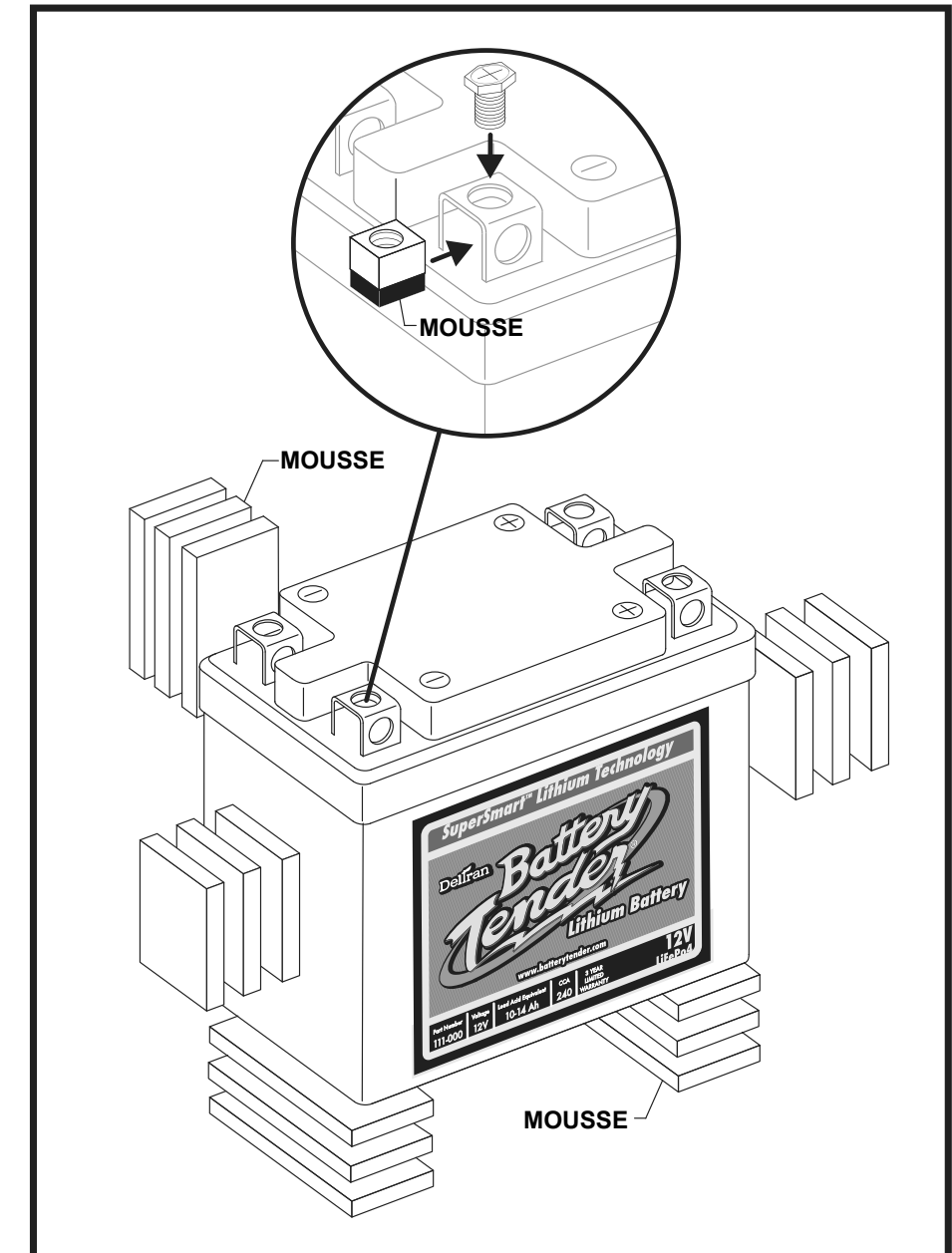

- c) Assurez-vous que la batterie est maintenant fixée fermement en place dans le boîtier de la batterie et que les câbles de batterie peuvent atteindre les bornes de la batterie sans aucun problème.
- d) La batterie au lithium Battery Tender^{MD} permet la connexion des cosses des câbles aux bornes de la partie supérieure ou à celles situées à l'avant. Choisissez le côté qui s'adapte le mieux à votre configuration.
- e) Utilisez le matériel fourni pour fixer les cosses à votre batterie. Ne serrez pas à l'excès les vis. (consultez le schéma ci-dessus)

- f) Une fois la batterie installée, vaporisez un produit anticorrosion de bonne qualité sur les bornes.
- g) Réinstallez les capuchons de protection de la batterie du véhicule, et couvrez les bornes inutilisées avec les capuchons fournis pour s'assurer que la batterie ne sera pas court-circuitée par une pièce quelconque du véhicule.
- h) Les batteries au lithium Battery Tender^{MD} sont préchargées à 70 % de leur capacité et doivent être rechargées avant leur utilisation.

UTILISATION

- a) Il existe certaines conditions pouvant détériorer toute batterie de démarrage au lithium, entre autres son stockage prolongé à des températures élevées et la décharge complète de la batterie.
- b) Lorsqu'on la compare aux batteries au plomb-acide, la batterie au lithium Battery Tender^{MD} a un taux moyen de décharge de moins de 5 % et peut être stockée pendant des périodes beaucoup plus longues sans aucun entretien.
- c) Si elle n'est pas soumise à une consommation de courant causée par votre véhicule lorsque le moteur est éteint, la batterie au lithium Battery Tender^{MD} peut être conservée pendant un an sans être endommagée.
- d) Pour le stockage à long terme, la température idéale est de 1 °C (34 °F).
- e) La batterie doit être stockée dans un état de charge minimum de 70 %.
- f) N'utilisez PAS la batterie à des températures inférieures à -10 °C (14 °F).

CHARGE

- a) N'utilisez PAS un chargeur à désulfatation ou à impulsions, cela endommagerait la batterie et annulerait ainsi la garantie.
- b) Les chargeurs standard pour batteries au plomb-acide peuvent être utilisés, à condition qu'ils ne fournissent pas plus de 14,8 V pendant la charge.
- c) Le courant de charge maximum est de 10 ampères.
- d) Il est fortement recommandé l'utilisation d'un chargeur spécifique pour batterie au lithium, tel que les chargeurs pour batterie au lithium Battery Tender^{MD}.
- e) Ne laissez pas la batterie au lithium se décharger au-dessous de 8 V, car cela pourrait endommager la batterie et annuler ainsi la garantie.
- f) Ne rechargez PAS la batterie à des températures inférieures à -10 °C (14 °F).

GARANTIE

(Amérique du Nord)

Garantie

- a) Deltran Battery Tender^{MD} offre une Garantie limitée de trois ans pour ses batteries au lithium, contre tout défaut de matériaux et de fabrication.
- b) Ne retournez PAS le produit sans numéro ARM (Autorisation de Retour de Marchandise, angl. RMA) ou avant de contacter d'abord Deltran Battery Tender^{MD} pour procéder à des diagnostics simples. Dans de nombreux cas, des problèmes peuvent être résolus avant le retour.
- c) Consultez notre site Web au www.batterytender.com pour les informations les plus récentes au sujet de la garantie.
- d) La garantie n'est pas transférable par l'acheteur d'origine.

Périodes de garantie

- 1) 0-12 mois : Remplacement gratuit avec reçu original ou enregistrement du produit sur notre site Web.
- 2) 13-24 mois : 50 % sur le prix de détail suggéré par le fabricant (PDSF) avec reçu original ou enregistrement sur le site Web.
- 3) 25-36 mois : 35 % sur le prix de détail suggéré par le fabricant (PDSF) avec reçu original ou enregistrement sur le site Web.
- * Les clients doivent payer les frais d'expédition initiaux pour le retour à Deltran des batteries. Deltran paiera l'expédition des batteries de remplacement retournées aux clients, sauf dans le cas de celles non accompagnées d'une copie du reçu et/ou du numéro ARM.

Les retours DOIVENT être accompagnés de :

- a) Une copie du reçu original à moins que la batterie ait été enregistrée sur notre site Web.
- b) Un numéro ARM de Deltran Battery Tender^{MD}.

Retours sans un reçu

- a) S'il n'y a pas de reçu, mais que nous pouvons déterminer à partir du numéro de série que la batterie est encore dans sa période de garantie, ou dans les trois premières années de vente de la batterie par Deltran, alors le client reçoit 35 % du PDSF pour ce type de batterie.
- b) Le client est responsable de tous les frais d'expédition.

Aucune défaillance détectée

- a) Tout produit jugé NON défectueux après son essai dans les installations de Deltran sera retourné au client et ce dernier paiera les frais d'expédition.

Conditions non couvertes

- a) Tout dommage physique à la batterie qui est survenu après son achat.
- b) Toute modification apportée à la batterie, y compris, mais sans s'y limiter, les modifications aux bornes.
- c) Toute corrosion causée par de l'eau salée.
- d) Toute tension de charge excessive de la batterie.
- e) Batterie déchargée en dessous de 8 V.
- f) Batterie achetée d'une source non autorisée.

Dommages durant l'expédition

- a) Tout article endommagé pendant le transport doit être rapporté à l'expéditeur immédiatement après ouverture de l'emballage.
- b) Avisez également Deltran au sujet de la situation.
- c) Tout emballage d'origine doit être conservé jusqu'à nouvel ordre.
- d) Deltran répondra en fournissant d'autres instructions.

Deltran Battery Tender®
Batería de litio, hierro y fosfato

INSTRUCCIONES DE SEGURIDAD IMPORTANTES

- 1) CONSERVE ESTAS INSTRUCCIONES
- 2) No tire la caja o la espuma del embalaje hasta que no se haya completado el montaje.

PRECAUCIONES

- a) No sumerja el la batería en agua.
- b) No ponga en contacto los terminales.
- c) No utilice ni almacene la batería cerca de fuentes de fuego o calor.
- d) No intercambie el terminal positivo (+) con el negativo (-).
- e) No exponga la batería al fuego ni aplique calor directamente sobre ella.
- f) No perforo la caja de la batería.
- g) No golpee, arroje ni someta a la batería a golpes físicos.
- h) No suelde directamente en los terminales de la batería.
- i) No intente modificar la batería de ninguna manera.
- j) No coloque la batería en un horno microondas o en un contenedor presurizado.
- k) No utilice la batería si desprende mal olor o calor.
- l) No permita que la tensión de carga supere los 14,8 V.
- m) NO utilice la batería a temperaturas inferiores a -10 °C (14 °F).
- n) NO utilice cargadores de plomo-ácido que usan una rutina de "anti-sulfatación" a alta tensión.
- o) Mantenga las baterías fuera del alcance de niños y mascotas.
- p) Descargue por completo la batería antes de desecharla.

ADVERTENCIA

- a) Tenga especial cuidado en reducir el riesgo de que se caiga una herramienta de metal en la batería. Pueden saltar chispas o cortocircuitarse la batería u otras partes eléctricas que puedan producir una explosión.
- b) No lleve puesto ningún objeto personal de metal tales como anillos, pulseras, collares o relojes cuando trabaje con cualquier batería. Una batería puede producir un cortocircuito de corriente suficientemente potente como para derretir un anillo de metal o similar, causando quemaduras graves.
- c) Para reducir el riesgo de explosión de la batería, siga las siguientes instrucciones y aquellas publicadas por el fabricante del equipamiento al lado del cual usted desea utilizar esta batería. Revise las marcas de precaución de estos productos y del motor.

INSTRUCCIONES DE MONTAJE

- a) Quite con cuidado la batería de plomo-ácido existente en su vehículo siguiendo las indicaciones de los fabricantes.
- b) A continuación, coloque la batería original al lado de su batería de litio Battery Tender® para comparar la diferencia de tamaño. La batería original puede ser de la misma anchura pero tiene mayor largura y altura. Para compensar la diferencia, aplicar la cantidad de espuma adhesiva necesaria a la batería de litio o a la caja de la batería.

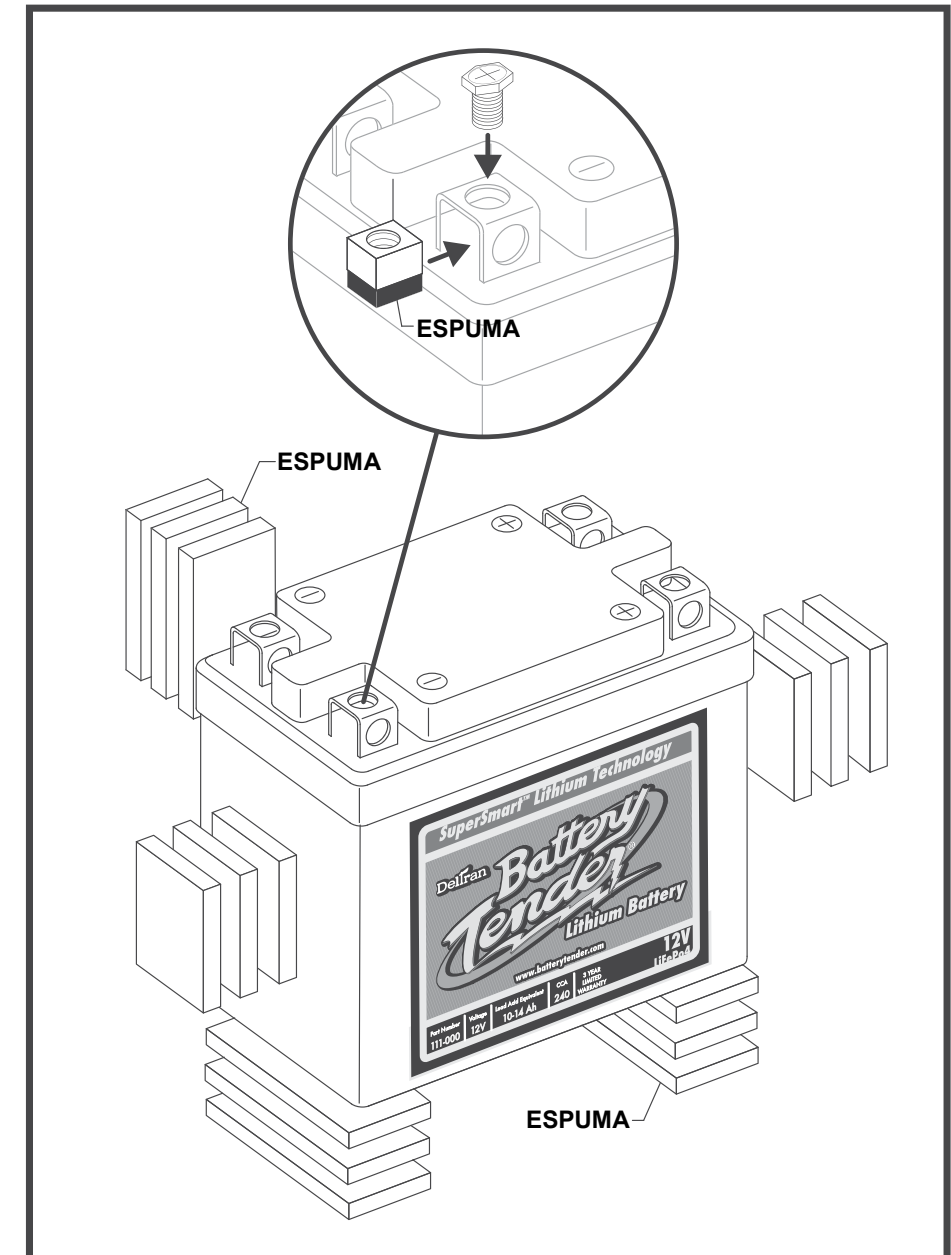

- c) Asegúrese de que ahora la batería encaja con seguridad en la caja de la batería y que permite que los cables de la batería alcancen los terminales de las baterías sin problema.
- d) La batería de litio Battery Tender® permite que los ojete de los cables estén conectados tanto desde la parte de arriba como desde la parte delantera de los terminales. escoja el lado más adecuado para su configuración.

- e) Utilice el hardware suministrado para sujetar los anillos a los terminales de su batería. No apriete los tornillos en exceso. (Véase diagrama en página anterior.)
- f) Una vez montado, aplique una buena cantidad de spray anticorrosión a los terminales.
- g) Vuelva a montar todas las tapas de protección de la batería y cubra los terminales que no se usen con las tapas suministradas para asegurarse de que la batería no puede entrar en cortocircuito con cualquier otra parte del vehículo.
- h) Battery Tender® las baterías de litio están precargadas al 70% de capacidad y deben cargarse antes de utilizarse.

USO

- a) Existen un par de condiciones perjudiciales para todas las baterías de arranque de litio, estas incluyen un almacenamiento prolongado a altas temperaturas y permitir que la batería se descargue por completo
- b) Comparadas con las baterías de plomo-ácido, la batería de litio Battery Tender® tiene menos del 5% de tasa media de autodescarga y puede almacenarse durante periodos mucho más largos sin mantenimiento.
- c) Si no hay tensión en el vehículo cuando el motor está apagado la batería de litio Battery Tender® puede almacenarse durante un año sin daños.
- d) Para el almacenamiento a largo plazo la temperatura ideal es de 1°C (34 °F).
- e) La batería debe almacenarse con una carga mínima del 70%.
- f) NO utilice la batería a temperaturas inferiores a -10 °C (14 °F).

CARGA

- a) No utilice desulfatación o cargador de pulso, esto podría dañar la batería y anular la garantía.
- b) Pueden utilizarse cargadores plomo-ácido estándar mientras no sobrepasen los 14,8 V durante la carga.
- c) La tasa máxima de carga es 10 A.
- d) Se recomienda encarecidamente utilizar un cargador específico de litio como los de las series de cargadores de litio Battery Tender®.
- e) No permita que la batería de litio se descargue por debajo de los 8 V ya que esto podría dañar la batería y anular la garantía.
- f) No cargue la batería a temperaturas inferiores a -10 °C (14 °F).

GARANTÍA (Norteamérica)

Garantía

- a) Deltran Battery Tender® ofrece una garantía limitada de tres años para sus baterías de litio, que cubre defectos de material o calidad.
- b) NO devuelva ningún producto sin una RMA# (Autorización de devolución de mercaderías) o sin antes ponerse en contacto con Deltran Battery Tender® para realizar un simple diagnóstico. En muchos casos, los problemas pueden resolverse antes de realizar la devolución.
- c) Visite nuestra página web www.batterytender.com para la última información actualizada sobre la garantía.
- d) La garantía no puede transferirse desde el comprador original.

Periodos de garantía

- 1) 0-12 meses: Sustitución sin cargo presentando la factura original o el registro del producto en nuestra página web.
- 2) 13-24 meses: 50% de descuento sobre el PVP presentando la factura original o con el registro en la página web.
- 3) 25-36 meses: 35% de descuento sobre el PVP presentando la factura original o con el registro en la página web.
- * Los clientes son responsables del pago de los cargos iniciales de envío para la devolución de las baterías. Deltran pagará los gastos de envío correspondientes al recambio de las baterías devueltas a los clientes excepto de aquellas sin copia de la factura y/o RMA#.

Las devoluciones DEBERÁN acompañarse de:

- a) Una copia de la factura original a no ser que la batería se haya registrado en nuestra página web.
- b) LA RMA# de Deltran Battery Tender®.

Devoluciones sin factura

- a) Si no hay factura pero si por el número de serie puede determinarse que la batería todavía está en periodo de garantía o dentro de los tres primeros años a partir de la venta de la batería Deltran, el cliente recibirá el 35% de descuento sobre el PVP por ese tipo de batería.
- b) El cliente deberá hacerse cargo de todos los gastos de envío.

No se encuentra ningún fallo

- a) Los productos a los que NO se le hayan encontrado defectos tras la comprobación en la casa sólo se devolverán a los clientes que se hagan cargo de los gastos de envío.

Condiciones no cubiertas

- a) Cualquier daño físico infringido a la batería tras las adquisición.
- b) Cualquier modificación a la batería, incluidos pero no limitadas a los terminales.
- c) Todo tipo de corrosión incluida aquella producida por el agua salada.
- d) Toda carga de la batería por encima de la tensión recomendada.
- e) Batería descargada por debajo de los 8 V.
- f) Adquisición de la batería de una fuente no autorizada.

Daños de envío

- a) Si un elemento resulta dañado durante el transporte, se debe informar inmediatamente al transportista al abrir el embalaje.
- b) Notifique de inmediato a Deltran sobre la situación.
- c) Se debe conservar el embalaje original hasta nueva información.
- d) Deltran responderá con instrucciones.

DELTRAN LITHIUM BATTERY CROSS REFERENCE

Deltran Part Number	Yuasa	Batteries Plus	EXIDE	Deka	Delco	Interstate	GS-Ztong Yee
BTL09A120C	12N11-3A-1	-	-	-	-	-	-
	12N5.5-3B	-	-	-	-	-	-
	12N5.5-4A	-	-	-	-	-	-
	12N5-4B	-	-	-	-	-	-
	12N9-3A	-	-	-	-	-	-
	12N9-4B-1	XT9-B	-	-	-	-	-
	YB12A-A	XT12A-A	12AA	-	MC1216	YB12A-A	CB12A-A
	YB4L-A	-	4L-A	-	-	YB4L-A	CB4L-A
	YB4L-B	XT4L-B	4L-B	-	MC0414	YB4L-B	CB4L-B
	YB5L-B	XT5L-B	5L-B	-	-	YB5L-B	CB5L-B
	YB7-A	XT7-A	7-A	-	-	YB7-A	CB7-A
	YB7B-B	-	-	-	-	-	-
	YB7C-A	XT7C-A	7C-A	-	-	YB7C-A	C87C-A
	YB7L-B	XT7L-B	7L-B	-	-	YB7L-B	CB7L-B
	YT7B-BS	XTA7B-BS	-	-	-	CYT7B-BS	GT7B-4
	YT9B-BS	-	-	-	-	CYT9B-BS	GT9B-4
	YTR9-BS	XTAX9-BS	-	-	-	-	-
	YTX4L-BS	XTAX4L-BS	4L-BS	-	GT4L-BS	CYTX4L-BS	GT4L-BS
	YTX5L-BS	XTAX5L-BS	5L-BS	-	GTX5L-BS	CYTX5L-BS	GTX5L-BS
	YTX7A-BS	XTAX7A-BS	7A-BS	-	-	CYTX7A-BS	GTX-7A-BS
	YTX7L-BS	XTAX7L-BS	7L-BS	-	-	CYTX7L-BS	-
YTX9-BS	XTAX9-BS	9-BS	ETX9	GTX9-BS	CYTX9-BS	GTX9-BS	
YTZ5S	-	-	-	-	-	-	
BTL14A240C	12N24-3	-	-	-	-	-	-
	12N9-3B	XT9L-B	-	-	-	-	-
	51814	-	-	-	-	-	-
	51913	-	-	-	-	-	-
	HYB16A-AB	XT16A-AB	16AA	-	-	HYB16A-AB	HCB16A-A
	SYB14L-A2	XT14L-A2	14-LA2	-	-	SYB14L-A2	SCB14-LA2
	SYB14L-B2	XT14L-B2	14-LB2	-	-	SYB14L-B2	SCB14-LB2
	SYB16L-B	XT16L-B	16L-B	-	-	SYB16L-B	SCB16L-B
	YB10L-A2	XT10L-A2	10LA2	-	MC1114	YB10L-A2	CB10L-A2
	YB10L-B	-	10L-B	-	-	YB10L-B	CB10L-B
	YB10L-B2	-	10L-B2	-	-	YB10L-B2	CB10L-B2
	YB12A-B	-	12A-B	-	-	YB12A-B	-
	YB12AL-A	XT12AL-A	12AL-A	-	-	YB12AL-A	CB12AL-A
	YB12AL-A2	XT12AL-A	-	-	-	-	-
	YB12B-B2	-	12B-B2	-	-	YB12B-B2	CB12B-B2
	YB12C-A	XT12C-A	12C-A	-	-	YB12C-A	-
	YB14-A2	XT14-A2 XTA14AH-BS	14-A2	-	-	YB14-A2	CB14-A2
	YB14-B2	XT14-A2	14-B2	-	-	YB14-B2	CB14-B2
	YB14L-A1	-	14L-A1	-	-	YB14L-A1	CB14L-A1
	YB14L-A2	XT14L-A2	14L-A2	-	MC1406	YB14L-A2	CB14L-A2
	YB14L-B2	XT14L-B2	14L-B2	-	-	YB14L-B2	CB14L-B2

DELTRAN LITHIUM BATTERY CROSS REF. (cont.)

GS-JSB	Motocross	NAPA	Sears	Wal-Mart	Yacht	Deltran Alt #1	Deltran Alt #2
-	-	-	-	-	-	BTL14A240C	-
-	-	-	-	-	-	-	-
-	-	-	-	-	-	-	-
-	-	-	-	-	-	-	-
-	-	-	-	-	-	BTL14A240C	-
-	-	-	-	-	-	BTL14A240C	-
GM12AZ-4A-1	M3212Y	740-1854	44358	ES12AA	CB12A-A	BTL14A240C	-
GM4A-3B	M224LA	-	44039	-	CB4L-A	-	-
GM4-3B	M324LB	740-1861	44014	-	CB4L-B	-	-
GM5Z-3B	M325LB	740-1868	44353	-	CB5L-B	-	-
GM7Z-4A	M227AY	-	44040	-	CB7-A	BTL14A240C	-
-	-	-	-	-	-	-	-
GM7CZ-3D	M227CY	M227CY	44041	-	CB7C-A	-	-
GM7-3B-1	M2273Y	-	44042	-	CB7L-B	BTL14A240C	-
-	M62T7B	-	-	-	-	BTL14A240C	-
-	M629B4	-	-	-	-	BTL14A240C	-
-	-	-	-	-	-	BTL14A240C	-
-	M62X4B	740-1865	44015	ES4LBS	CT4L-BS	-	-
-	M32X5B	-	44022	-	-	-	-
-	M32X7A	-	44023	-	CTX7A-BS	BTL14A240C	-
GTX7L-BS	M327BS	-	44024	-	CTX7L-BS	-	-
-	M329BS	740-1825	44025	-	CTX9-BS	BTL14A240C	-
-	-	-	-	-	-	-	-
-	-	-	-	-	-	BTL18A300C	BTL24A360C
-	-	-	-	-	-	-	-
-	-	-	-	-	-	-	-
GM16-T	M32H6B	740-1867	44064	-	HCB16A-A	-	-
-	M2214S	-	44061	-	SCB14-LA2	-	-
-	M22B4S	-	44062	-	SCB14-LB2	-	-
-	M22S6A	-	44069	-	SCB16L-B	BTL18A300C	BTL24A360C
GM10Z-3A	M3210Y	740-1857	44355	ES10LA2	CB10L-A2	-	-
GM10-3B	M321LB	740-1831	44047	-	CB10L-B	-	-
-	M221L2	740-1832	44048	-	-	-	-
-	M222AB	-	44053	-	CB12A-B	-	-
GM12AZ-3A-1	M3221Y	740-1873	44052	-	CB12AL-A	-	-
-	-	-	-	-	-	-	-
GM12B-4B	M221B2	-	44054	-	CB12B-B2	-	-
GM12CZ-4A-2	M222CA	-	44055	-	CB12C-A	-	-
GM14Z-4A	M3214H	740-1864	44363	-	CB14-A2	-	-
-	M224B2	-	44060	-	CB14-B2	-	-
GM14Z-3A-1	M22141	-	44057	-	CB14L-A1	-	-
GM14Z-3A	M3214Y	740-1851	44364	ES14L-A2	CB14L-A2	-	-
GM14Z-3B	M2214B	740-1828	44059	-	CB14L-B2	-	-

DELTRAN LITHIUM BATTERY CROSS REF. (cont.)

Deltran Part Number	Yuasa	Batteries Plus	EXIDE	Deka	Delco	Interstate	GS-Ztong Yee	
BTL14A240C (continued)	YB16AL-A2	XT16AL-A2	16ALA2	-	CB16AL-A2	YB16AL-A2	CB16AL-A2	
	YB16-B	XT16-B	16B	-	MC1912	YB16-B	CB16-B	
	YB16B-A	-	16B-A	-	-	YB16B-A	-	
	YB16B-A1	XT16B-A1	16B-A1	-	-	YB16B-A1	-	
	YB16L-B	XT16L-B	16LB	-	-	YB16L-B	CB16L-B	
	YB9-B	XT9-B	9-B	-	-	YB9-B	CB9-B	
	YB9L-A2	-	9L-A2	-	-	YB9L-A2	CB9L-A2	
	YB9L-B	XT9L-B	9LB	-	-	YB9L-B	CB9L-B	
	YHD-12H	XTHD-12	-	-	-	-	-	
	YT12A-BS	XTA12A-BS	-	-	-	-	-	
	YT12B-BS	XTA12B-BS	-	-	-	CYT12B-BS	GT12B-4	
	YT14B-BS	-	-	-	-	CYT14B-BS	GT14B-4	
	YTX12-BS	XTAX12-BS	12-BS	ETX12	GTX12-BS	CYTX12-BS	GTX12-BS	
	YTX14	XTAX14-BS	-	-	-	-	-	
	YTX14AH-BS	XT14-A2	-	ETX15	-	CYTX14AH-BS	-	
	YTX14AHL-BS	-	-	ETX15L	-	CYTX14AHL-BS	-	
	YTX14-BS	XTAX14-BS	14-BS	ETX14	GTX14-BS	CYTX14-BS	GTX14-BS	
	YTX14H	-	-	-	-	-	-	
	YTX14L-BS	-	-	-	-	CYTX14L-BS	-	
	YTX15L-BS	-	-	-	-	CYTX15L-BS	-	
	YTX16-BS	XTAX16-BS	-	-	-	CYTX16-BS	-	
	YTX16-BS-1	XTAX16-BS-1	-	-	-	-	-	
	YTZ10S	XTAX7A-BS XTAZ10S	-	-	-	FAYTZ10S	-	
	YTZ12S	XTAZ12S	-	-	-	FAYTZ12S	-	
	YTZ14S	XTAZ14S	-	-	-	FAYTZ14S	-	
	BTL18A300C	GYZ20L	-	-	-	-	-	-
		Y50-N18L-A	XT50-N18L-A3 XTAX24HL-BS	50N18LA2	-	MC2008	Y50-N18L-A	C50-N18L-A3
Y50-N18L-A3		XT50-N18L-A3	50N18LA3	-	-	Y50-N18L-A3	C50-N18L-A3	
Y60-N24-A		-	60-N24-A	-	-	Y60-N24-A	C60-N24L-A	
YB18-A		XT18-A	18-A	-	-	YB18-A	CB18-A	
YTX20-BS		XTAX20H-BS	16-BS	ETX16	-	CYTX20-BS	GT16-BS	
YTX20L-BS		XTAX20HL-BS	16L-BS 20L-BS	ETX16L ETX20L	-	CYTX20L-BS	GT16L-BS GTX20L-BS	
BTL24A360C	YB16-B	XT16-B	-	-	-	-	-	
	YB16-B-CX	XT16-B-LM	16-B-LM	-	-	YB16-B-LM	GT16-BS	
	YB16HL-A-CX	XT16HL-A-LM	16HL-A-LM	-	-	YB16HL-A-LM	GT16L-BS	
	YB18L-A	XT18L-A	18LA	-	-	YB18L-A	CB18L-A	
	YB30CL-B	XT30CL-B	-	-	-	-	-	
	YTX20H-BS	XTAX16-BS	-	-	-	-	-	
	YTX24HL-BS	XTAX24HL-BS	18L-BS	ETX18L	-	CYTX24HL-BS	GTX18L-BS	
	YTX20HL	XTAX20HL-BS	-	-	-	-	-	
	YTX20HL-BS-PW	-	-	-	-	-	-	
BTL35A480C	YIX30L-BS	XTA30LBS	-	ETX30L	-	CYIX30L-BS	-	

DELTRAN LITHIUM BATTERY CROSS REF. (cont.)

GS-JSB	Motocross	NAPA	Sears	Wal-Mart	Yacht	Deltran Alt #1	Deltran Alt #2
GM16A-3A	M32162	740-1877	44063	-	CB16AL-A2	-	-
GM16Z-4BH	M3216Y	740-1852	44366	ES16B	CB16-B	BTL18A300C	BTL24A360C
GM16B-4A	M2216B	-	44066	-	CB16B-A	-	-
-	M22161	-	44067	-	CB16B-A1	-	-
GM16Z-3B	M3216K	740-1827	44065	-	CB16L-B	BTL18A300C	BTL24A360C
GM9Z-4B	M329BY	740-1858	44356	-	CB9-B	-	-
-	M2292Y	-	44044	-	CB9L-A2	-	-
GM9Z-3B	M329LY	740-1837	44045	-	CB9L-B	-	-
-	-	-	-	-	-	BTL18A300C	BTL24A360C
-	-	-	-	-	-	-	-
-	M6212B	-	-	-	-	-	-
-	M624B4	-	-	-	-	-	-
-	M3RH2S	740-1866	44016	ES12BS	CTX12-BS	-	-
-	-	-	-	-	-	-	-
-	M62H4A	-	44004	-	-	-	-
-	M62H4L	-	44005	-	-	-	-
-	M3RH4S	740-1886	44017	ES14BS	CTX14-BS	-	-
-	-	-	-	-	-	-	-
-	-	-	-	-	-	-	-
-	M6215L	-	44162	-	-	-	-
-	M32X6S	-	-	-	-	-	-
-	-	-	-	-	-	-	-
-	M7210A	-	-	-	-	-	-
-	M7212A	-	-	-	-	-	-
-	M72Z14	-	-	-	CTX20L-BS	-	-
-	-	-	-	-	-	BTL24A360C	BTL35A480C
GM18Z-3A(S)	M3218Y	-	-	ES50N-N18L-A	SCB50-N18L-A	BTL24A360C	BTL35A480C
-	M328A3	740-1855	44359	-	C50-N18L-A3	BTL24A360C	BTL35A480C
-	M2224A	-	44074	-	C60-N24-A	BTL24A360C	BTL35A480C
GM18A-4A	M321Y	740-1874	44070	-	CB18-A	BTL24A360C	BTL35A480C
-	M32RBS	-	44028	-	-	BTL24A360C	BTL35A480C
-	M320BS	-	44027	-	-	BTL24A360C	BTL35A480C
-	-	-	-	-	CTX20L-BS	-	-
-	-	-	-	-	-	BTL35A480C	-
-	M3216C	-	44029	-	CB16-B-LM	BTL35A480C	-
-	M2H16C	-	-	-	CB16HL-A-LM	BTL35A480C	-
GM18A-3A	M3218L	740-1871	44071	-	CB18L-A	BTL35A480C	-
-	-	-	-	-	-	BTL35A480C	-
-	-	-	-	-	-	BTL35A480C	-
-	M6250H	-	44006	-	-	BTL35A480C	-
-	-	-	-	-	-	BTL35A480C	-
-	-	-	-	-	-	BTL35A480C	-
YGIX30	M7230L	-	-	-	-	-	-

MAKE	YEAR/YEARS	MODEL	PART#	UPGRADE1	UPGRADE2
MOTORCYCLES					
Aprilia	2011-2013	Dorsoduro, Caponordo	BTL14A240C		
Aprilia	2011-2013	RS4 125	BTL09A120C		
Aprilia	2011-2013	RS4 50	BTL09A120C		
Aprilia	2011-2013	Turono V4R	BTL14A240C		
Aprilia	2009-2013	Dorsoduro	BTL14A240C		
Aprilia	2009-2013	MANA850, GT	BTL14A240C		
Aprilia	2009-2013	RSV4 R, Factory	BTL14A240C		
Aprilia	2009-2013	Shiver	BTL14A240C		
Aprilia	2009-2012	Pegaso Strada, Factory, Trail	BTL14A240C		
Aprilia	2010-2011	RS125	BTL14A240C		
Aprilia	2004-2011	RSV 1000 R, Factory	BTL14A240C		
Aprilia	2003-2011	Tuono 1000 R, Factory	BTL14A240C		
Aprilia	1933-2010	RXV450	BTL09A120C	BTL14A240C	
Aprilia	1933-2010	RXV550	BTL09A120C	BTL14A240C	
Aprilia	1933-2010	SVX450	BTL09A120C	BTL14A240C	
Aprilia	1933-2010	SVX550	BTL09A120C	BTL14A240C	
Aprilia	2001-2009	RSV 1000 Mille	BTL14A240C		
Aprilia	2004-2005	Atlantic 200cc	BTL14A240C		
Aprilia	2004-2005	Mojito 150cc	BTL09A120C		
Aprilia	2004-2005	Mojito 50cc	BTL09A120C		
Aprilia	2004-2005	Rally	BTL09A120C		
Aprilia	2004-2005	Scarabeo 500cc	BTL14A240C		
Aprilia	2003-2005	Atlantic 500cc	BTL14A240C		
Aprilia	2001-2005	RSV 1000 Mille R	BTL14A240C		
Aprilia	2001-2005	SR50 Ditech	BTL09A120C		
Aprilia	2000-2005	RS50	BTL09A120C		
Aprilia	2001-2004	RST Futura	BTL14A240C		
Aprilia	2000-2004	RS250	BTL09A120C		
Aprilia	2000-2004	Scarabeo 150cc	BTL14A240C		
Aprilia	2002-2003	ETV Caponord	BTL14A240C		
Aprilia	2001-2003	SL Falco	BTL14A240C		
Aprilia	2000-2003	Scarabeo 50cc	BTL09A120C		
Aprilia	2000-2001	SR50	BTL09A120C		
Aprilia	2000	Pegaso	BTL14A240C		
Aprilia	2000	RSV 1000 Mille	BTL14A240C		
Aprilia	1999	RSV 1000 Mille SP	BTL14A240C		
ATK	1996-2001	All Electric Start Models	BTL09A120C		
ATK	1991-1995	All Electric Start Models	BTL09A120C	BTL14A240C	
Benelli	1933-2011	125 Cross	No Equivalent		
Benelli	1933-2011	125 Custom Guzzi	BTL09A120C		
Benelli	1933-2011	125 Guzzi	BTL09A120C		
Benelli	1933-2011	125 Jarno (c/avv.)	BTL09A120C	BTL14A240C	
Benelli	1933-2011	125 Scooter Benelli	BTL14A240C		
Benelli	1933-2011	125-2 CSE	No Equivalent		
Benelli	1933-2011	125CS	BTL09A120C	BTL14A240C	
Benelli	1933-2011	125T Sport	No Equivalent		
Benelli	1933-2011	250 (4 Cilindri)	BTL09A120C	BTL14A240C	
Benelli	1933-2011	250-2C	No Equivalent		

MAKE	YEAR/YEARS	MODEL	PART#	UPGRADE1	UPGRADE2
Benelli	1933-2011	650 Tornado U.T.	BTL09A120C	BTL14A240C	
Benelli	1933-2011	900 (6 Cilindri)	BTL35A480C		
Benelli	1933-2011	Devil 50 (c/avv.)	BTL09A120C		
Benelli	1933-2011	KBX 50 Race	BTL09A120C		
Benelli	1933-2011	Scooty LX/DLX	BTL09A120C		
Big Dog	1933-2011	All Models	BTL24A360C	BTL35A480C	
Bimota	1998-2000	SB8R, SB8RS	BTL14A240C		
Bimota	1997-1999	DB3 Mantra	BTL09A120C		
Bimota	1997-1999	SB6R	BTL14A240C		
Bimota	1996-1999	YB11	BTL14A240C		
Bimota	1997	DB2 Final Edition	BTL14A240C		
Bimota	1995-1997	SB6, SB7	BTL09A120C		
Bimota	1993-1995	DB2	BTL14A240C		
Bimota	1992-1995	YB8/YB10	BTL14A240C		
Bimota	1991-1995	Tesi	BTL14A240C		
BMW	2013	F700GS	BTL14A240C		
BMW	2013	HP4	No Equivalent		
BMW	2005-2013	R1200GS	BTL14A240C		
BMW	2011-2013	K1600GT, GTL	BTL14A240C		
BMW	2009-2013	K1300R, S	BTL14A240C		
BMW	2009-2013	R1200GS Avdenture	BTL14A240C		
BMW	2009-2013	S1000RR	BTL14A240C		
BMW	2008-2013	F800ST, GS, R	BTL14A240C		
BMW	2005-2013	R1200RT	BTL14A240C		
BMW	2005-2013	R1200S, R	BTL14A240C		
BMW	1993-2013	F650, G650GS	BTL14A240C		
BMW	2008-2012	F650GS	BTL14A240C		
BMW	2010-2011	HP2 Sport / Megamoto	BTL14A240C		
BMW	2009-2011	G450	No Equivalent		
BMW	2009-2011	K1300GT	BTL14A240C		
BMW	2009-2011	S1000RR DWA	BTL14A240C		
BMW	1993-2011	R 26	No Equivalent		
BMW	2005-2009	K1200LT, GT,	BTL14A240C		
BMW	2005-2009	K1200R, S,	BTL14A240C		
BMW	2000-2005	R1150GS, R	BTL14A240C		
BMW	1999-2005	K1200LT, GT, RS, S	BTL14A240C		
BMW	1998-2005	R1200C	BTL14A240C		
BMW	1997-2005	K1200RS	BTL14A240C		
BMW	1994-2000	R1100GS	BTL14A240C		
BMW	1994-2000	R1100R	BTL14A240C		
BMW	1993-2000	R1100RS, RT	BTL14A240C		
BMW	1993-2000	R1100S	BTL14A240C		
BMW	1995-1997	R850R	BTL14A240C		
BMW	1992-1996	K75RT	BTL35A480C		
BMW	1980-1996	R80GS, R80ST	BTL14A240C		
BMW	1993-1995	K75	BTL14A240C		
BMW	1990-1995	K1100LT/RS	BTL14A240C		
BMW	1987-1995	R100GS, PD, R, RS, RT	BTL35A480C		
BMW	1985-1995	K75, RT	BTL35A480C		
BMW	1985-1995	K75C	BTL14A240C		

MAKE	YEAR/YEARS	MODEL	PART#	UPGRADE1	UPGRADE2
BMW	1984-1995	R65	BTL35A480C		
BMW	1984-1995	R80, R80RT	BTL35A480C		
BMW	1987-1993	K75C	BTL14A240C		
BMW	1983-1993	"All "K" Models"	BTL35A480C		
BMW	1985-1986	K75	BTL14A240C		
BMW	1985-1986	K75C	BTL14A240C		
BMW	1985-1986	K75S	BTL14A240C		
BMW	1978-1984	R80/7, R80RT	BTL35A480C		
BMW	1978-1984	R65LS	BTL14A240C		
BMW	1976-1984	R100/7	BTL35A480C		
BMW	1976-1984	R100CS	BTL35A480C		
BMW	1976-1984	R75/7	BTL35A480C		
BMW	1969-1976	R75/6	BTL35A480C		
BMW	1969-1976	R90/6, R90S	BTL35A480C		
BMW	1970-1973	R50/5	BTL14A240C		
BMW	1970-1973	R60/5	BTL14A240C		
BMW	1970-1973	R75/5	BTL14A240C		
BMW	1955-1969	R69 - R69S	No Equivalent		
BMW	1955-1969	R50/2 Twin Cylinders	No Equivalent		
BMW	1955-1969	R50/S Twin Cylinders	No Equivalent		
BMW	1955-1969	R60, R60/2 Twin Cylinders	No Equivalent		
BSA	1933-2011	250, 350, 400, 441, 500 (12V)	BTL09A120C	BTL14A240C	
BSA	1933-2011	250, 350, 650 (6V)	No Equivalent		
BSA	1933-2011	500 Gold Star	No Equivalent		
BSA	1933-2011	600, 650, 750 (12V)	BTL09A120C	BTL14A240C	
BSA	1933-2011	Rocket 750, Thunderbolt	BTL14A240C		
BSA	1933-2011	Spitfire HK35, Starfire B25	BTL14A240C		
Buell	2008-2010	1125R, 1125CR	BTL14A240C		
Buell	2006-2010	XB12X, XT Ulysses	BTL14A240C		
Buell	2004-2010	XB12Ss, Scg, Lightning	BTL14A240C		
Buell	2004-2010	XB12R Firebolt	BTL14A240C		
Buell	2002-2010	XB9R Firebolt, XB9SX Lightning	BTL14A240C		
Buell	2009	Buell Racing 1125RR	No Equivalent		
Buell	2000-2009	Blast	BTL14A240C		
Buell	1999-2002	X1 Lightning	BTL18A300C	BTL24A360C	BTL35A480C
Buell	1997-2002	M2 Cyclone	BTL18A300C	BTL24A360C	BTL35A480C
Buell	1997-2002	S3, S3T Thunderbolt	BTL18A300C	BTL24A360C	BTL35A480C
Buell	1996-1999	S1 Lightning	BTL14A240C		
Buell	1994-1996	S2, S2T Thunderbolt	BTL18A300C	BTL24A360C	BTL35A480C
Buell	1991-1993	RSS1200	BTL18A300C	BTL24A360C	BTL35A480C
Buell	1989-1993	RS1200	BTL18A300C	BTL24A360C	BTL35A480C
Buell	1988-1990	RR1200	BTL18A300C	BTL24A360C	BTL35A480C
Buell	1987	RR1000	BTL18A300C	BTL24A360C	BTL35A480C
Cagiva	1933-2011	Elefant E900	BTL14A240C		
Cagiva	1998	K3, W4	BTL09A120C		
Cagiva	1997	N 90	BTL14A240C		
Cagiva	1994-1997	City, Lucky, Explorer	BTL09A120C		
Cagiva	1994-1997	Elefant	BTL24A360C	BTL35A480C	
Cagiva	1994-1997	Roadster	BTL14A240C		
Cagiva	1991-1997	Supercity	BTL14A240C		

MAKE	YEAR/YEARS	MODEL	PART#	UPGRADE1	UPGRADE2
Cagiva	1990-1997	Mito	BTL14A240C		
Cagiva	1987-1990	Freccia C9, /C10R, /C12R	BTL14A240C		
Cagiva	1989	Elefant Bifaro	BTL14A240C		
Cagiva	1988	T4 E Elefant	BTL14A240C		
Cagiva	1987-1988	Crouser	BTL14A240C		
Cagiva	1987	T4 E Elefant, W12	No Equivalent		
Cagiva	1987	T4R	BTL14A240C		
Cagiva	1986	Elefant 2 Cyl.	BTL14A240C		
Can-Am	2008-2012	Spyder	BTL24A360C	BTL35A480C	
Cannondale	2002-2003	C440, E440, S440, X440, X440S	No Equivalent		
Cannondale	2000-2001	EX400, MX400, XC400	BTL09A120C		
CCM	1996-2001	All Electric Start Models	BTL09A120C	BTL14A240C	
Derbi	1933-2011	All Models	BTL09A120C		
Ducati	2013	Diavel	BTL14A240C		
Ducati	2013	Monster 796cc	BTL14A240C		
Ducati	2013	Street Fighter	BTL14A240C		
Ducati	2011-2013	1199, Panigale (S)	BTL09A120C	BTL14A240C	
Ducati	2010-2013	Hypermotard 796cc	BTL14A240C		
Ducati	2010-2013	Multistrada	BTL14A240C		
Ducati	2009-2013	Monster 1100cc	BTL14A240C		
Ducati	2008-2013	848, Corse SE	BTL14A240C		
Ducati	2008-2013	Monster 696cc	BTL14A240C		
Ducati	2007-2013	Hypermotard 1100cc	BTL14A240C		
Ducati	2009-2012	Street Fighter, S	BTL14A240C		
Ducati	2009-2011	1198, MY08, SP, R	BTL14A240C		
Ducati	1933-2011	Alazzurra, Indiana, Pantah	BTL14A240C		
Ducati	1933-2011	GT, GTS	BTL35A480C		
Ducati	1933-2011	GTL, GTV	BTL24A360C	BTL35A480C	
Ducati	1933-2011	GT, Luguna Seca	BTL35A480C		
Ducati	1933-2011	Indiana	BTL14A240C		
Ducati	1933-2011	Kick-Start	BTL09A120C	BTL14A240C	
Ducati	1933-2011	Pantah 600cc	BTL14A240C		
Ducati	1933-2011	Pantah 500cc	BTL14A240C		
Ducati	1933-2011	Sport 500cc	BTL24A360C	BTL35A480C	
Ducati	1933-2011	SS Supersport Kick-Str.	BTL09A120C	BTL14A240C	
Ducati	1933-2011	TL	BTL14A240C		
Ducati	2001-2010	Various All other models	BTL14A240C		
Ducati	2008-2009	Desmosedici RR	BTL14A240C		
Ducati	2007-2009	Multistrada	BTL14A240C		
Ducati	2007-2009	1098	BTL14A240C		
Ducati	1933-2009	GT1000, Touring, Sport 1100S	BTL14A240C		
Ducati	1999-2000	996, S, SPS	BTL14A240C		
Ducati	1999-2000	ST4	BTL14A240C		
Ducati	1997-2000	748 Strada Biposto, SP, SPS	BTL14A240C		
Ducati	1997-2000	Monster 750cc	BTL14A240C		
Ducati	1997-2000	Suport Touring 2 (ST2)	BTL14A240C		
Ducati	1994-2000	Monster 900cc	BTL14A240C		
Ducati	1990-2000	SS 750cc	BTL14A240C		
Ducati	1989-2000	SS 900cc	BTL14A240C		
Ducati	1997-1998	Supersport FE	BTL14A240C		

MAKE	YEAR/YEARS	MODEL	PART#	UPGRADE1	UPGRADE2
Ducati	1994-1998	916 Biposto, Senna, Strada	BTL14A240C		
Ducati	1994-1998	I.E., SP, SP S	BTL14A240C		
Ducati	1992-1996	SL	BTL14A240C		
Ducati	1990-1995	SP, SP II, SP IV, SP V	BTL14A240C		
Ducati	1990-1994	I.E. Paso	BTL18A300C	BTL24A360C	BTL35A480C
Ducati	1991-1992	S Superbike	BTL14A240C		
Ducati	1990-1992	Paso	BTL18A300C	BTL24A360C	BTL35A480C
Ducati	1990-1991	851 Superbike	BTL14A240C		
Ducati	1989-1990	Sport 750cc	BTL14A240C		
Ducati	1987-1990	F1, Montjuich, Paso	BTL14A240C		
Ducati	1982	SS Supersport, Replica	BTL14A240C		
Ducati	1981	SS Kick-Starter	BTL09A120C	BTL14A240C	
Ducati	1981	SS Replica	BTL09A120C	BTL14A240C	
Excelsior Henderson	1999-2000	Super X	BTL18A300C	BTL24A360C	BTL35A480C
Gas Gas	1933-2008	FSR450	No Equivalent		
Gas Gas	1998-2001	Pampera 320cc	BTL09A120C		
Gas Gas	1996-2001	Pampera 250cc	BTL09A120C		
Gas Gas	1997	Pampera 370cc	BTL09A120C		
Gilera	1933-2011	Apache E-Starter	BTL14A240C		
Gilera	1933-2011	Apache Kick-Start	BTL09A120C		
Gilera	1933-2011	Arizona	BTL14A240C		
Gilera	1933-2011	Arizona E-Starter	BTL14A240C		
Gilera	1933-2011	Arizona Kick-Start	BTL09A120C		
Gilera	1933-2011	Arizona Rally	BTL14A240C		
Gilera	1933-2011	Crona E-Starter	BTL14A240C		
Gilera	1933-2011	Crona Kick-Start	BTL09A120C		
Gilera	1933-2011	CX E-Starter	BTL14A240C		
Gilera	1933-2011	CX Kick-Start	BTL09A120C		
Gilera	1933-2011	Dakota E-Starter 500cc	BTL14A240C		
Gilera	1933-2011	Dakota E-Starter 350cc	BTL14A240C		
Gilera	1933-2011	Dakota Kick-Start 500cc	BTL09A120C		
Gilera	1933-2011	Dakota Kick-Start 350cc	BTL09A120C		
Gilera	1933-2011	ER E-Starter	BTL14A240C		
Gilera	1933-2011	ER Kick-Start	BTL09A120C		
Gilera	1933-2011	Fast Bike	BTL14A240C		
Gilera	1933-2011	Fast Bike E-Starter	BTL14A240C		
Gilera	1933-2011	Fast Bike Kick-Start	BTL09A120C		
Gilera	1933-2011	Freestyle E-Starter	BTL14A240C		
Gilera	1933-2011	Freestyle Kick-Start	BTL09A120C		
Gilera	1933-2011	GFR E-Starter	BTL14A240C		
Gilera	1933-2011	GFR Kick-Start	BTL09A120C		
Gilera	1933-2011	GSA E-Starter	BTL09A120C		
Gilera	1933-2011	KK, KZ E-Starter	BTL14A240C		
Gilera	1933-2011	KK, KZ Kick-Start	BTL09A120C		
Gilera	1933-2011	Motocarro	No Equivalent		
Gilera	1933-2011	MX1, MXR E-Starter	BTL14A240C		
Gilera	1933-2011	MX1, MXR Kick-Start	BTL09A120C		
Gilera	1933-2011	Nebraska E-Starter	BTL14A240C		
Gilera	1933-2011	Nebraska Kick-Start	BTL09A120C		
Gilera	1933-2011	R1, R1S EI.-Starter	BTL14A240C		

MAKE	YEAR/YEARS	MODEL	PART#	UPGRADE1	UPGRADE2
Gilera	1933-2011	R1, R1S Kick-Start	BTL09A120C		
Gilera	1933-2011	RC Rally	BTL14A240C		
Gilera	1933-2011	RTX, RV, RX E-Starter 200cc	BTL14A240C		
Gilera	1933-2011	RTX, RV, RX E-Starter 125cc	BTL14A240C		
Gilera	1933-2011	RTX, RV, RX Kick-Start 200cc	BTL09A120C		
Gilera	1933-2011	RTX, RV, RX Kick-Start 125cc	BTL09A120C		
Gilera	1933-2011	RV NGR E-Starter	BTL14A240C		
Gilera	1933-2011	RV NGR Kick-Start	BTL09A120C		
Gilera	1933-2011	Sioux E-Starter	BTL09A120C		
Gilera	1933-2011	SPO1, SPO2 E-Starter	BTL14A240C		
Gilera	1933-2011	SPO1, SPO2 Kick-Start	BTL09A120C		
Gilera	1933-2011	Stalker, Storm, Top Rally	BTL09A120C		
Gilera	1933-2011	T4	BTL09A120C		
Gilera	1933-2011	TOP Rally E-Starter	BTL14A240C		
Gilera	1933-2011	TOP Rally Kick-Start	BTL09A120C		
Gilera	1933-2011	Top Rally, XRT	BTL14A240C		
Gilera	1933-2011	Typhoon 125cc	BTL09A120C	BTL14A240C	
Gilera	1933-2011	XR1, XR2 E-Starter	BTL14A240C		
Gilera	1933-2011	XR1, XR2 Kick-Start	BTL09A120C		
Gilera	1933-2011	XRT	BTL14A240C		
Gilera	1997	Bullit, Easy Moving, Runner	BTL09A120C		
Gilera	1997	Runner	BTL09A120C		
Gilera	1997	Typhoon 50cc	BTL09A120C		
Gilera	1995-1997	Eaglet	BTL09A120C		
Gilera	1933	Nordwest	BTL14A240C		
Gilera	1933	RC 600C	BTL14A240C		
Harley Davidson	2011-2013	MT500 (Military)	BTL14A240C		
Harley Davidson	2011-2013	FLS (Softail)	BTL18A300C	BTL24A360C	BTL35A480C
Harley Davidson	2011-2013	FXD (Dyna)	BTL18A300C	BTL24A360C	BTL35A480C
Harley Davidson	2010-2013	FLH, FLT (Touring)	BTL35A480C		
Harley Davidson	2008-2013	VRSC V-Rod	BTL18A300C	BTL24A360C	BTL35A480C
Harley Davidson	2007-2013	CVO FLH (Touring)	BTL35A480C		
Harley Davidson	2007-2013	CVO FLST (Softail)	BTL18A300C	BTL24A360C	BTL35A480C
Harley Davidson	2007-2013	FXD Series (Dyna)	BTL18A300C	BTL24A360C	BTL35A480C
Harley Davidson	2004-2013	XL, XLH (Sportster) 1200cc	BTL14A240C		
Harley Davidson	2004-2013	XL, XLH (Sportster) 883cc	BTL14A240C		
Harley Davidson	2007-2012	FXST, FLST Series (Softail)	BTL18A300C	BTL24A360C	BTL35A480C
Harley Davidson	2007-2011	FL, FLH Series (Touring)	BTL35A480C		
Harley Davidson	2007-2010	CVO FXD (Dyna)	BTL18A300C	BTL24A360C	BTL35A480C
Harley Davidson	2002-2007	VRSC V-Rod	BTL14A240C		
Harley Davidson	2000-2006	FL, FLH Series (Touring)	BTL35A480C		
Harley Davidson	2000-2006	FXST, FLST Series (Softail)	BTL18A300C	BTL24A360C	BTL35A480C
Harley Davidson	1999-2006	FXD Series (Dyna)	BTL18A300C	BTL24A360C	BTL35A480C
Harley Davidson	1987-2003	XL, XLH (Sportster) 1200cc	BTL18A300C	BTL24A360C	BTL35A480C
Harley Davidson	1997-2003	XL, XLH (Sportster) 883cc	BTL18A300C	BTL24A360C	BTL35A480C
Harley Davidson	1999-2000	FXR Series	BTL18A300C	BTL24A360C	BTL35A480C
Harley Davidson	1999	FL, FLH Series (Touring)	BTL35A480C		
Harley Davidson	1991-1999	FLST Series (Softail)	BTL18A300C	BTL24A360C	BTL35A480C
Harley Davidson	1997-1999	FXD/FXST Series (Dyna)	BTL18A300C	BTL24A360C	BTL35A480C
Harley Davidson	1997-1998	FL, FLH Series (Touring)	BTL35A480C		

MAKE	YEAR/YEARS	MODEL	PART#	UPGRADE1	UPGRADE2
Harley Davidson	1991-1996	FXD/FXST Series (Dyna)	BTL18A300C	BTL24A360C	BTL35A480C
Harley Davidson	1986-1996	XLH (Sportster)	BTL18A300C	BTL24A360C	BTL35A480C
Harley Davidson	1978-1996	FL, FLH Series (Touring)	BTL24A360C	BTL35A480C	
Harley Davidson	1979-1994	FX/FXR Series	BTL18A300C	BTL24A360C	BTL35A480C
Harley Davidson	1987-1993	XL Series (Sportster)	BTL18A300C	BTL24A360C	BTL35A480C
Harley Davidson	1984-1990	FXST, FLST Series (Softail)	BTL18A300C	BTL24A360C	BTL35A480C
Harley Davidson	1983-1985	1000 XLX-61, XR1000	BTL18A300C	BTL24A360C	BTL35A480C
Harley Davidson	1979-1985	XL Series (Sportster)	BTL18A300C	BTL24A360C	BTL35A480C
Harley Davidson	1977-1978	XLCR Cafe Racer	BTL18A300C	BTL24A360C	BTL35A480C
Harley Davidson	1975-1978	SS250, SX250	BTL09A120C	BTL14A240C	
Harley Davidson	1975-1978	SXT125	BTL09A120C	BTL14A240C	
Harley Davidson	1974-1978	SS175, SX175	BTL09A120C	BTL14A240C	
Harley Davidson	1974-1978	SS125, SX125	BTL09A120C	BTL14A240C	
Harley Davidson	1973-1978	TX125	BTL09A120C	BTL14A240C	
Harley Davidson	1971-1978	FX Series (Electric Start)	BTL18A300C	BTL24A360C	BTL35A480C
Harley Davidson	1970-1978	XLCH Series (Sportster Kick Start)	BTL09A120C	BTL14A240C	
Harley Davidson	1967-1978	XLH (Sportster Electric Start)	BTL14A240C	BTL18A300C	BTL24A360C
Harley Davidson	1965-1977	FL/FLH Series (Touring)	BTL14A240C	BTL18A300C	BTL24A360C
Harley Davidson	1973-1976	Z90	BTL09A120C	BTL14A240C	
Harley Davidson	1971-1972	FX Series (Kick Start)	BTL09A120C	BTL14A240C	
Honda	2013	CB500X, F	BTL14A240C		
Honda	2013	CBR500R	BTL14A240C		
Honda	2013	VFR1200XD	BTL14A240C		
Honda	2012-2013	NC700X	BTL14A240C		
Honda	2011-2013	CBR250R	BTL09A120C		
Honda	2010-2013	CB1100	BTL14A240C		
Honda	2010-2013	NT700V	BTL14A240C		
Honda	2010-2013	VT750C, C2, C2B, RS Shadow	BTL14A240C		
Honda	2010-2013	VFR1200F	BTL14A240C		
Honda	2009-2013	CB1000R	BTL14A240C		
Honda	2009-2013	DN-01	BTL14A240C		
Honda	2009-2013	GL1800 Gold Wing, F6B	BTL18A300C	BTL24A360C	BTL35A480C
Honda	2009-2013	VT1300CS, CR, CT, CXA FURY	BTL14A240C		
Honda	2008-2013	CBR1000RR	No Equivalent		
Honda	2008-2013	CRF230L, M	No Equivalent		
Honda	2006-2013	CRF150F	BTL09A120C		
Honda	2005-2013	CRF450X	No Equivalent		
Honda	2004-2013	CRF250X	BTL09A120C		
Honda	2003-2013	CRF230F, L (-'07)	BTL09A120C		
Honda	2003-2013	ST1300, A, P	BTL14A240C		
Honda	2001-2013	CB1300 Super Four	BTL14A240C		
Honda	2001-2013	CBR600F4i, 600RR	BTL14A240C		
Honda	1996-2013	CMX250C Rebel	BTL09A120C		
Honda	1993-2013	XR650L	BTL09A120C	BTL14A240C	
Honda	2010-2012	XL1000V Varadero	No Equivalent		
Honda	2003-2012	VTX1300C, R, S, Retro	BTL14A240C		
Honda	2002-2012	VFR800, A Interceptor, ABS	BTL14A240C		
Honda	2002-2011	VTX1800C, F, N, R Retro, S	BTL18A300C	BTL24A360C	BTL35A480C
Honda	1933-2011	NT650V	BTL09A120C	BTL14A240C	
Honda	1933-2011	SLR650	BTL09A120C	BTL14A240C	

MAKE	YEAR/YEARS	MODEL	PART#	UPGRADE1	UPGRADE2
Honda	1933-2011	Vigor 650	BTL09A120C	BTL14A240C	
Honda	2009-2010	C110	No Equivalent		
Honda	2009-2010	CBF1000F	BTL14A240C		
Honda	2004-2009	VT750C, CA, C2 Shadow	BTL14A240C		
Honda	1991-2009	CB250 Nighthawk	BTL09A120C		
Honda	2004-2008	VT750C, CA, C2	BTL14A240C		
Honda	2001-2008	GL1800 Gold Wing	BTL18A300C	BTL24A360C	BTL35A480C
Honda	2004-2007	CBR1000RR	BTL14A240C		
Honda	2004-2007	VT600C, CD Shadow Deluxe	BTL14A240C		
Honda	1998-2007	VT1100C, C3, T Shadow (Spirit, Aero, A. C. E. Tourer)	BTL14A240C		
Honda	2000-2007	VT1100C2 Shadow Sabre VT1100C, C3, T Shadow	BTL14A240C		
Honda	2004-2006	CB600F (599)	BTL09A120C		
Honda	2002-2006	CB900F (919)	BTL14A240C		
Honda	2000-2006	RVT1000R RC51	BTL14A240C		
Honda	2004-2005	NRX1800 Valkyrie Rune	BTL18A300C	BTL24A360C	BTL35A480C
Honda	2001-2005	VTR1000F Super Hawk	BTL14A240C		
Honda	1997-2004	CBR1100XX	BTL14A240C		
Honda	2002-2003	CBR954RR	BTL14A240C		
Honda	2001-2003	VT750DC, DCA, DCB Shadow	BTL14A240C		
Honda	1998-2003	VT750C, CA, CD Shadow	BTL14A240C		
Honda	1997-2003	GL1500 Valkyrie	BTL14A240C		
Honda	1994-2003	VF750C, C2, D Magna	BTL14A240C		
Honda	1991-2003	CB750 Nighthawk	BTL14A240C		
Honda	1988-2003	VT600C, CD Shadow Deluxe, VLX	BTL09A120C	BTL14A240C	
Honda	1991-2002	ST1100, ABS-TCS, 1100A	BTL14A240C		
Honda	2000-2001	CBR929RR, RE	BTL14A240C		
Honda	1998-2001	VFR800FI Interceptor	BTL14A240C		
Honda	1997-2000	VTR1000F Super Hawk	BTL14A240C		
Honda	1988-2000	GL1500 Gold Wing	BTL24A360C	BTL35A480C	
Honda	1987-2000	CBR600	BTL09A120C	BTL14A240C	
Honda	1995-1999	VT1100C2 Shadow A. C. E.	BTL14A240C		
Honda	1993-1999	CBR900R, RR	BTL09A120C	BTL14A240C	
Honda	1989-1998	PC800 Pacific Coast	BTL14A240C		
Honda	1990-1997	VFR750F	BTL14A240C		
Honda	1985-1997	VT1100C Shadow Spirit	BTL14A240C		
Honda	1991-1996	EZ90 Cub	BTL09A120C		
Honda	1991-1996	XR250L	BTL09A120C		
Honda	1987-1996	CBR1000F Hurricane	BTL14A240C		
Honda	1994-1995	CB1000	BTL14A240C		
Honda	1994	RVF750R (RC45)	BTL09A120C	BTL14A240C	
Honda	1991-1994	CT70	BTL09A120C		
Honda	1988-1991	NT650 Hawk GT	BTL09A120C	BTL14A240C	
Honda	1990	NS50F	No Equivalent		
Honda	1990	VFR750R (RC30)	BTL09A120C	BTL14A240C	
Honda	1989-1990	CB400F CB-1	BTL09A120C	BTL14A240C	
Honda	1989-1990	GB500	BTL14A240C		
Honda	1989-1990	XL600V Transalp	BTL14A240C		
Honda	1988-1990	NX125	BTL09A120C		
Honda	1988-1990	NX250	BTL09A120C		
Honda	1988-1990	VTR250 Interceptor VTR	BTL14A240C		

MAKE	YEAR/YEARS	MODEL	PART#	UPGRADE1	UPGRADE2
Honda	1988-1989	NX650	BTL09A120C	BTL14A240C	
Honda	1988	VF750C V45 Magna	BTL09A120C	BTL14A240C	
Honda	1988	VT800C Shadow	BTL14A240C		
Honda	1988	ZB50	BTL09A120C		
Honda	1987	CB700SC Nighthawk 'S'	BTL14A240C		
Honda	1987	TR200 Fat Cat	BTL09A120C		
Honda	1987	VF700C Magna	BTL09A120C	BTL14A240C	
Honda	1986-1987	CMX450C Rebel	BTL09A120C	BTL14A240C	
Honda	1986-1987	TLR200 Reflex	BTL09A120C		
Honda	1986-1987	VFR700 Interceptor	BTL14A240C		
Honda	1986-1987	VT700C Shadow	BTL14A240C		
Honda	1985-1987	CMX250C Rebel, LTD	BTL14A240C		
Honda	1984-1987	GL1200 Gold Wing	BTL24A360C	BTL35A480C	
Honda	1983-1987	XL600R	No Equivalent		
Honda	1982-1987	XL250R	No Equivalent		
Honda	1986	CT110 Trail	No Equivalent		
Honda	1986	TR200 Fat Cat	BTL09A120C	BTL14A240C	
Honda	1986	VFR750F Interceptor	BTL14A240C		
Honda	1984-1986	VF1000R, F	BTL14A240C		
Honda	1984-1986	VF500F Interceptor	BTL09A120C	BTL14A240C	
Honda	1984-1986	VF700C Magna	BTL14A240C		
Honda	1983-1986	VF1100C V65 Magna	BTL18A300C	BTL24A360C	BTL35A480C
Honda	1983-1986	VT500C Shadow	BTL09A120C	BTL14A240C	
Honda	1982-1986	CB450SC Nighthawk, T	BTL09A120C	BTL14A240C	
Honda	1985	XL125S	No Equivalent		
Honda	1984-1985	VF1100S V65 Sabre	BTL18A300C	BTL24A360C	BTL35A480C
Honda	1984-1985	VF500C V30 Magna	BTL09A120C	BTL14A240C	
Honda	1984-1985	VF700F Interceptor	BTL14A240C		
Honda	1984-1985	VF700S Sabrer	BTL14A240C		
Honda	1984-1985	VT700C Shadow	BTL14A240C		
Honda	1984-1985	XL350R	No Equivalent		
Honda	1983-1985	XL100S	No Equivalent		
Honda	1983-1984	VF750F V45 Interceptor	BTL14A240C		
Honda	1983-1984	VT500FT Ascot	BTL09A120C	BTL14A240C	
Honda	1983-1984	XL200R	No Equivalent		
Honda	1980-1984	CB750SC Nighthawk	BTL14A240C		
Honda	1979-1984	XL125S	No Equivalent		
Honda	1983	CB1000C Custom	BTL14A240C		
Honda	1983	CB1100F Super Sport	BTL14A240C		
Honda	1983	CB550SC Nighthawk	BTL14A240C		
Honda	1983	CX650C Custom	BTL14A240C		
Honda	1983	CX650T Turbo	BTL14A240C		
Honda	1983	GL650I Silver Wing Interstate	BTL14A240C		
Honda	1983	VT750C Shadow	BTL14A240C		
Honda	1982-1983	CM250C Custom	BTL14A240C		
Honda	1982-1983	CM450A Hondamatic, E	BTL09A120C	BTL14A240C	
Honda	1982-1983	FT500 Ascot	BTL14A240C		
Honda	1982-1983	NU50 Urban Express	No Equivalent		
Honda	1982-1983	NU50M Urban Express Deluxe	No Equivalent		
Honda	1982-1983	VF750C V45 Magna	BTL14A240C		

MAKE	YEAR/YEARS	MODEL	PART#	UPGRADE1	UPGRADE2
Honda	1982-1983	VF750S V45 Sabre	BTL14A240C		
Honda	1980-1983	GL1100 Gold Wing	BTL24A360C	BTL35A480C	
Honda	1979-1983	XL185S	No Equivalent		
Honda	1982	CB650SC Nighthawk	BTL09A120C	BTL14A240C	
Honda	1982	CBX1000 Super Sport (Opt)	BTL24A360C	BTL35A480C	
Honda	1982	MB5	No Equivalent		
Honda	1982	XL500R	No Equivalent		
Honda	1981-1982	CM200T Twinstar	BTL14A240C		
Honda	1981-1982	GL500, I Silver Wing	BTL14A240C		
Honda	1981-1982	NX50M Express SR	No Equivalent		
Honda	1980-1982	CB750C Custom	BTL14A240C		
Honda	1980-1982	CB900C, F	BTL14A240C		
Honda	1979-1982	CB650, Custom	BTL09A120C	BTL14A240C	
Honda	1979-1982	CBX1000 Super Sport	BTL18A300C	BTL24A360C	BTL35A480C
Honda	1978-1982	CX500, C, D, T '	BTL14A240C		
Honda	1975-1982	CB750F Super Sport	BTL14A240C		
Honda	1969-1982	CB750K Four	BTL14A240C		
Honda	1979-1981	CM400 (All)	BTL09A120C	BTL14A240C	
Honda	1979-1981	XL500S	No Equivalent		
Honda	1978-1981	CB400T Hawk, Hawk II	BTL09A120C	BTL14A240C	
Honda	1978-1981	XL250S	No Equivalent		
Honda	1980	CM200T Twinstar	No Equivalent		
Honda	1979-1980	XL100S	No Equivalent		
Honda	1973-1980	CB125S	No Equivalent		
Honda	1979	CB750K Limited Edition	BTL14A240C		
Honda	1979	NA50 Express II	No Equivalent		
Honda	1978-1979	CB400TI Hawk I	BTL14A240C		
Honda	1978-1979	CM185T Twinstar	No Equivalent		
Honda	1978-1979	NC50 Express	No Equivalent		
Honda	1975-1979	GL1000 Gold Wing	BTL24A360C	BTL35A480C	
Honda	1978	CB400A	BTL09A120C	BTL14A240C	
Honda	1976-1978	CB750A Hondamatic	BTL24A360C	BTL35A480C	
Honda	1974-1978	CB550 Four, K, SS	BTL09A120C	BTL14A240C	
Honda	1974-1978	XL350	No Equivalent		
Honda	1973-1978	XL175	No Equivalent		
Honda	1977	NC50 Express	No Equivalent		
Honda	1976-1977	CJ360T '	BTL14A240C		
Honda	1975-1977	CB400F Super Sport	BTL09A120C	BTL14A240C	
Honda	1974-1976	CB200, T	BTL14A240C		
Honda	1974-1976	CB360, G, T	BTL09A120C	BTL14A240C	
Honda	1974-1976	MT125 Elsinore	No Equivalent		
Honda	1974-1976	MT250 Elsinore	No Equivalent		
Honda	1974-1976	XL100	No Equivalent		
Honda	1972-1976	XL250	No Equivalent		
Honda	1971-1976	CB500 Four, Twin	BTL09A120C	BTL14A240C	
Honda	1974-1975	CL360 Scrambler	BTL09A120C	BTL14A240C	
Honda	1974	CL200 Scrambler	BTL14A240C		
Honda	1968-1974	CB350 Super Sport Four	BTL09A120C	BTL14A240C	
Honda	1967-1974	CB450, SS	BTL09A120C	BTL14A240C	
Honda	1967-1974	CL450 Scrambler	BTL09A120C	BTL14A240C	

MAKE	YEAR/YEARS	MODEL	PART#	UPGRADE1	UPGRADE2
Honda	1973	SL70 Motosport	No Equivalent		
Honda	1972-1973	CT70, 70H	No Equivalent		
Honda	1971-1973	SL125 Motosport	No Equivalent		
Honda	1970-1973	CL100, S Scrambler	No Equivalent		
Honda	1970-1973	SL100 Motosport	No Equivalent		
Honda	1973-1969	SL350 Motosport	BTL09A120C		
Honda	1969-1973	CB175 Super Sport	BTL14A240C		
Honda	1968-1973	CL175 Scrambler	BTL14A240C		
Honda	1968-1973	CL350 Scrambler	BTL09A120C	BTL14A240C	
Honda	1971-1972	SL70 Motosport	No Equivalent		
Honda	1970-1972	CB100 Super Sport	No Equivalent		
Honda	1970-1972	SL175 Motosport	BTL09A120C		
Honda	1969-1971	CT70 Trail, 70H	No Equivalent		
Honda	1969-1970	CA175 Touring (CD175K3)	No Equivalent		
Honda	1969-1970	Z50A (K1)	No Equivalent		
Honda	1968-1969	CA175 Touring (CD175)	No Equivalent		
Honda	1967-1969	CL125A Scrambler (Twin)	No Equivalent		
Honda	1967-1969	SS125A Super Sport	No Equivalent		
Honda	1965-1969	CB160 Sport	BTL14A240C		
Honda	1965-1969	S65 Sport (CS65)	No Equivalent		
Honda	1963-1969	CA77 Dream Touring (late)	BTL09A120C	BTL14A240C	
Honda	1959-1969	C110, CA110	No Equivalent		
Honda	1966-1968	CL160 Scrambler	BTL14A240C		
Honda	1965-1968	CL77 Scrambler	BTL09A120C		
Honda	1961-1968	CB77 Super Hawk	BTL09A120C	BTL14A240C	
Honda	1963-1966	CA72 Dream Touring (late)	BTL09A120C	BTL14A240C	
Honda	1961-1966	CB72 Hawk	BTL09A120C	BTL14A240C	
Honda	1962-1965	C, CA105T Trail	No Equivalent		
Honda	1962-1965	CL72 Scrambler	BTL09A120C		
Husaberg	2013	All Electric Start Models '13	BTL09A120C		
Husaberg	2004-2012	All Electric Start Models '04-'12	No Equivalent		
Husaberg	1997-2003	All Electric Start Models '97-'03	BTL09A120C	BTL14A240C	
Husqvarna	2013	NUDA900	BTL14A240C		
Husqvarna	2011	TE	No Equivalent		
Husqvarna	2011	TE, TXC 511cc	No Equivalent		
Husqvarna	2011	TE, TXC 250cc	No Equivalent		
Husqvarna	2010	TC, TXC, TE, SMR 510cc	No Equivalent		
Husqvarna	2010	TC, TXC, TE, SMR 450cc	No Equivalent		
Husqvarna	2010	TC, TXC, TE, SMR 310cc	No Equivalent		
Husqvarna	2000-2001	TE410E	BTL14A240C		
Husqvarna	2000-2001	TE610E, SM610S	BTL14A240C		
Hyosung	2010-2013	ST7	BTL14A240C		
Hyosung	2009-2013	GT250, R	BTL14A240C		
Hyosung	2009-2013	GV250	BTL09A120C	BTL14A240C	
Hyosung	2009-2013	GT650, R, S	BTL14A240C		
Hyosung	2009-2013	GV650, SE	BTL14A240C		
Indian	2002-2003	1442 Scout, Spirit	BTL24A360C	BTL35A480C	
Indian	2002-2003	1638 Chief	BTL24A360C	BTL35A480C	
Indian	1999-2001	All Models	BTL24A360C	BTL35A480C	
Kawasaki	2011-2013	Ninja 1000	BTL09A120C	BTL14A240C	

MAKE	YEAR/YEARS	MODEL	PART#	UPGRADE1	UPGRADE2
Kawasaki	2011-2013	ZX10R	No Equivalent		
Kawasaki	2011-2013	ZX10R ABS	BTL14A240C		
Kawasaki	2008-2013	EX250, Ninja 250R	BTL09A120C	BTL14A240C	
Kawasaki	2009-2013	VN1700 Voyager, Nomad, Vaquero	BTL14A240C		
Kawasaki	2009-2013	Z750 (EU)	BTL09A120C	BTL14A240C	
Kawasaki	2009-2013	ZRX1200 DAEG	BTL14A240C		
Kawasaki	2008-2013	KLE650 Versys	BTL14A240C		
Kawasaki	2008-2013	ZG1400 Concours, ABS	BTL14A240C		
Kawasaki	2008-2013	ZX600-FA Ninja ZX-6R	BTL09A120C	BTL14A240C	
Kawasaki	2006-2013	KLX250S, SF	BTL09A120C		
Kawasaki	2006-2013	Vulcan 900 Classic, Custom	BTL14A240C		
Kawasaki	2006-2013	Ninja 650R, Ninja 650R ABS	BTL14A240C		
Kawasaki	2006-2013	Ninja ZX-14R, ABS	BTL14A240C		
Kawasaki	2003-2013	Z1000	BTL09A120C	BTL14A240C	
Kawasaki	1987-2013	KL650-A, E, KLR	BTL14A240C		
Kawasaki	2009-2012	ER6n	BTL14A240C		
Kawasaki	2004-2012	VN2000-A Vulcan	BTL14A240C		
Kawasaki	2008-2010	KLX450R	No Equivalent		
Kawasaki	2004-2010	ZX1000-C Ninja ZX-10R	BTL14A240C		
Kawasaki	2001-2010	BN125 Eliminator	BTL14A240C		
Kawasaki	2000-2010	KL250 Super Sherpa	BTL09A120C		
Kawasaki	1996-2010	EN500-C Vulcan LTD	BTL14A240C		
Kawasaki	1994-2010	EX500-D Ninja 500	BTL14A240C		
Kawasaki	2005-2009	ZZR600	BTL09A120C	BTL14A240C	
Kawasaki	2004-2009	VN1600-B Vulcan Mean Streak	BTL14A240C		
Kawasaki	2003-2009	VN1600-A Vulcan Classic, D, Nomad	BTL14A240C		
Kawasaki	1996-2009	VN1500-D, E, N Vulcan Classic	BTL14A240C		
Kawasaki	1998-2008	ZX600-G, J Ninja ZX-6R	BTL09A120C	BTL14A240C	
Kawasaki	1995-2007	EX250 Ninja	BTL09A120C		
Kawasaki	2005-2006	ZR750 (Z750S)	BTL09A120C	BTL14A240C	
Kawasaki	2004-2006	VN800-A, B, E Vulcan, Classic, Drifter	BTL14A240C		
Kawasaki	2003-2006	ZX600-K, M, N Ninja ZX-6RR	BTL09A120C	BTL14A240C	
Kawasaki	2003-2006	ZX636-B, C Ninja ZX-6R, ABS	BTL09A120C	BTL14A240C	
Kawasaki	1986-2006	VN750-A Vulcan	BTL14A240C		
Kawasaki	1986-2006	ZG1000-A Concours	BTL18A300C	BTL24A360C	BTL35A480C
Kawasaki	1982-2003/2005	KZ1000-P Police	BTL18A300C	BTL24A360C	BTL35A480C
Kawasaki	2002-2005	ZZR1200	BTL14A240C		
Kawasaki	2001-2005	ZRX1200R	BTL14A240C		
Kawasaki	2000-2005	Ninja ZX-12R	BTL14A240C		
Kawasaki	1999-2005	VN1500-G, J, L, R Vulcan Nomad, Drifter	BTL14A240C		
Kawasaki	1985-2005	KL250-D KLR	BTL09A120C		
Kawasaki	2002-2004	ZZR600	BTL14A240C		
Kawasaki	2003	KLX400R, KLX400SR	BTL09A120C	BTL14A240C	
Kawasaki	2002-2003	VN1500-P Vulcan Mean Streak	BTL14A240C		
Kawasaki	2000-2003	ZR-7, S	BTL14A240C		
Kawasaki	2000-2003	ZX900- E, F Ninja (ZX-9R)	BTL09A120C	BTL14A240C	
Kawasaki	1996-2003	ZX750-P Ninja ZX-7R	BTL14A240C		
Kawasaki	1995-2003	VN800-A, B, C, E Vulcan, Classic, Drifter	BTL14A240C		
Kawasaki	1986-2003	1200 ZG1200 Voyager XII	BTL24A360C	BTL35A480C	
Kawasaki	1984-2003	Ninja GPZ900R ZX900A1-A16	BTL14A240C		

MAKE	YEAR/YEARS	MODEL	PART#	UPGRADE1	UPGRADE2
Kawasaki	2000-2002	W650	BTL14A240C		
Kawasaki	1993-2002	ZX600-E, F Ninja ZX-6, 6R	BTL14A240C		
Kawasaki	1995-2001	ZX1100-D Ninja ZX-11	BTL14A240C		
Kawasaki	1999-2000	ZRX1100	BTL14A240C		
Kawasaki	1998-1999	ZX900-C Ninja (ZX-9R)	BTL09A120C	BTL14A240C	
Kawasaki	1996-1997	VN1500-C Vulcan L	BTL24A360C	BTL35A480C	
Kawasaki	1995-1997	ZX1100-E (GPz1100)	BTL14A240C		
Kawasaki	1994-1997	ZX900-B Ninja (ZX-9R)	BTL14A240C		
Kawasaki	1991-1997	ZX750 Ninja ZX-7RR	BTL09A120C	BTL14A240C	
Kawasaki	1987-1998	VN1500 Vulcan 88, SE	BTL24A360C	BTL35A480C	
Kawasaki	1986-1997	ZL600 (All)	BTL09A120C	BTL14A240C	
Kawasaki	1993-1996	KLX650C, R	BTL09A120C	BTL14A240C	
Kawasaki	1990-1996	EN500-A Vulcan	BTL09A120C	BTL14A240C	
Kawasaki	1985-1996	ZX600-A, B, C, D Ninja	BTL09A120C	BTL14A240C	
Kawasaki	1992-1995	ZR1100	BTL14A240C		
Kawasaki	1991-1995	ZX750-J Ninja ZX-7	BTL14A240C		
Kawasaki	1993-1994	ZX1100-D Ninja ZX-11 (CN)	BTL14A240C		
Kawasaki	1991-1994	ZR750-C Zephyr	BTL14A240C		
Kawasaki	1986-1994	EX250 Ninja	BTL14A240C		
Kawasaki	1993	KZ750-L Ninja	BTL09A120C	BTL14A240C	
Kawasaki	1990-1993	ZX1100-C Ninja ZX-11	BTL14A240C		
Kawasaki	1988-1993	EL250, HS	BTL14A240C		
Kawasaki	1987-1993	EX500-A	BTL14A240C		
Kawasaki	1990-1992	ZR550-B Zephyr	BTL09A120C	BTL14A240C	
Kawasaki	1990-1991	KL650-B Tengai	BTL14A240C		
Kawasaki	1989-1990	ZX750-H Ninja ZX-7	BTL14A240C		
Kawasaki	1987-1990	ZX750-F Ninja	BTL14A240C		
Kawasaki	1986-1990	ZX10R	BTL14A240C		
Kawasaki	1985-1990	EN450-A 454 LTD	BTL09A120C	BTL14A240C	
Kawasaki	1988-1989	ZX1000-B Ninja ZX10	BTL14A240C		
Kawasaki	1983-1988	ZN1300-A Voyager	BTL14A240C	BTL18A300C	BTL24A360C
Kawasaki	1981-1988	KZ305 CSR, LTD	BTL14A240C		
Kawasaki	1987	ZL1000-A	BTL14A240C		
Kawasaki	1986-1987	ZX1000-A Ninja 1000R, GPZ1000RX	BTL14A240C		
Kawasaki	1985-1986	KL600-B KLR	BTL14A240C		
Kawasaki	1985-1986	ZL900-A Eliminator	BTL14A240C		
Kawasaki	1984-1986	ZX550-A GPz	BTL09A120C	BTL14A240C	
Kawasaki	1985	VN700-A Vulcan	BTL14A240C		
Kawasaki	1984-1985	ZN1100-B LTD	BTL14A240C		
Kawasaki	1984-1985	ZN700-A LTD	BTL14A240C		
Kawasaki	1984-1985	ZN750-A LTD	BTL14A240C		
Kawasaki	1983-1985	ZX750-E Turbo, GPz	BTL14A240C		
Kawasaki	1984	KL600-A KLR	BTL09A120C		
Kawasaki	1984	KZ550-F LTD	BTL09A120C	BTL14A240C	
Kawasaki	1984	KZ700-A	BTL09A120C	BTL14A240C	
Kawasaki	1983-1984	ZX1100-A GPz	BTL14A240C	BTL18A300C	BTL24A360C
Kawasaki	1983	EX305-B GP	BTL14A240C		
Kawasaki	1983	KZ550-F Spectre	BTL09A120C	BTL14A240C	
Kawasaki	1983	KZ750-F LTD, Spectre	BTL14A240C		
Kawasaki	1982-1983	KZ1000-R Replica	BTL18A300C	BTL24A360C	BTL35A480C

MAKE	YEAR/YEARS	MODEL	PART#	UPGRADE1	UPGRADE2
Kawasaki	1982-1983	KZ550-H GP	BTL09A120C	BTL14A240C	
Kawasaki	1981-1983	KZ1000, LTD, CSR	BTL18A300C	BTL24A360C	BTL35A480C
Kawasaki	1981-1983	KZ1100-A, LTD	BTL18A300C	BTL24A360C	BTL35A480C
Kawasaki	1981-1983	KZ650-H CSR	BTL09A120C	BTL14A240C	
Kawasaki	1980-1983	KZ250 CSR, LTD	BTL14A240C		
Kawasaki	1980-1983	KZ440 (All)400 KH400-A	BTL09A120C	BTL14A240C	
Kawasaki	1980-1983	KZ550, LTD, GP	BTL09A120C	BTL14A240C	
Kawasaki	1980-1983	KZ750-E, H, L LTD	BTL09A120C	BTL14A240C	
Kawasaki	1982	KZ1100-B GP	BTL14A240C	BTL18A300C	BTL24A360C
Kawasaki	1982	KZ750-R GP	BTL09A120C	BTL14A240C	
Kawasaki	1979-1982	KZ1300 Touring	BTL24A360C	BTL35A480C	
Kawasaki	1981	KZ1100-B GP	BTL18A300C	BTL24A360C	BTL35A480C
Kawasaki	1980-1981	KZ1000-C Police	BTL18A300C	BTL24A360C	BTL35A480C
Kawasaki	1980	KZ1000-G Classic	BTL14A240C		
Kawasaki	1979-1980	KZ1000-E ST, Shaft	BTL18A300C	BTL24A360C	BTL35A480C
Kawasaki	1977-1980	KZ1000, LTD	BTL14A240C		
Kawasaki	1977-1980	KZ650 SR, LTD, Custom	BTL14A240C		
Kawasaki	1978-1979	KZ1000-C Police, Z1-R	BTL14A240C		
Kawasaki	1978-1979	KZ200-A	BTL14A240C		
Kawasaki	1977-1979	KZ400 Deluxe	BTL09A120C	BTL14A240C	
Kawasaki	1976-1979	KZ750, LTD, CSR	BTL14A240C		
Kawasaki	1974-1979	KZ400-D, H	BTL09A120C	BTL14A240C	
Kawasaki	1978	KZ400-C	BTL09A120C		
Kawasaki	1976-1978	KH400-A	BTL09A120C		
Kawasaki	1976-1977	KZ900, LTD	BTL14A240C		
Kawasaki	1976-1977	KZ400-aS	BTL09A120C		
Kawasaki	1976	KH250-A	BTL09A120C		
Kawasaki	1976	KH500-A	BTL14A240C		
Kawasaki	1972-1976	Z900 (Z1 Series)	BTL14A240C		
Kawasaki	1974-1975	S3 Series	BTL09A120C		
Kawasaki	1973-1975	F11 Series	No Equivalent		
Kawasaki	1973-1975	F9 Series	No Equivalent		
Kawasaki	1969-1975	H1 Series	BTL14A240C		
Kawasaki	1973-1975	S1 Series	BTL09A120C		
Kawasaki	1972-1975	H2 Series	BTL09A120C		
Kawasaki	1972-1973	S2 Series	BTL09A120C		
Kawasaki	1972	F9 Series	No Equivalent		
Kawasaki	1971-1972	F8 Series	No Equivalent		
Kawasaki	1970-1971	F5 Series	No Equivalent		
Kawasaki	1966-1971	A1 Series	BTL14A240C		
Kawasaki	1966-1971	A7 Series	BTL14A240C		
Kawasaki	1969-1970	F4 Series	BTL09A120C		
Kawasaki	1969-1970	W Series	BTL09A120C	BTL14A240C	
KTM	2009-2013	450SMR	BTL09A120C		
KTM	2013	Adventure 1190cc	BTL14A240C		
KTM	2013	Duke 690c	BTL09A120C	BTL14A240C	
KTM	2013	Duke 200cc	BTL09A120C	BTL14A240C	
KTM	2013	Duke 125cc	BTL09A120C		
KTM	2013	EXC-F	BTL09A120C		
KTM	2013	Freeride	BTL09A120C		

MAKE	YEAR/YEARS	MODEL	PART#	UPGRADE1	UPGRADE2
KTM	2013	SX-F, EXC, EXC-F	BTL09A120C		
KTM	2011-2013	SX-F 450cc	BTL09A120C		
KTM	2011-2013	SX-F 350cc	BTL09A120C		
KTM	2011-2013	XC, XC-W, EXC-F	BTL09A120C		
KTM	2009-2013	Enduro R	BTL14A240C		
KTM	2009-2013	RC8	BTL14A240C		
KTM	2009-2013	Supermoto, SM R 990cc	BTL14A240C		
KTM	2009-2013	Supermoto, SM R 690cc	BTL14A240C		
KTM	2005-2013	EXC, Racing	BTL09A120C		
KTM	2003-2013	Adventure 990cc	BTL14A240C		
KTM	2003-2013	Super Duke	BTL14A240C		
KTM	2011-2012	EXC-F, XC-W, XCF-W	BTL09A120C		
KTM	2011-2012	XC-F	BTL09A120C		
KTM	2011-2012	XC, EXC, XC-W	BTL09A120C		
KTM	2009-2012	Duke 690cc	BTL14A240C		
KTM	2009-2012	XC-W 530cc	BTL09A120C		
KTM	2005-2012	EXC, Racing	BTL09A120C		
KTM	2009-2011	Superenduro	BTL14A240C		
KTM	2005-2011	EXC, Racing	BTL09A120C		
KTM	2009-2010	SX-F, XC-F, XC-W	BTL09A120C		
KTM	2009-2010	XC-W 400cc	BTL09A120C		
KTM	2009-2010	EXC, Racing	BTL09A120C		
KTM	2009-2010	EXF	BTL09A120C		
KTM	2003-2009	SMC, SXC	BTL14A240C		
KTM	2003-2008	Duke II, LC4, Adventure	BTL14A240C		
KTM	2003-2005	EXC, Racing	BTL09A120C		
KTM	2003-2005	EXC, Racing	BTL09A120C		
KTM	2003-2005	EXC, Racing	BTL09A120C		
KTM	2003-2005	EXC, Racing	BTL09A120C		
KTM	2003	EXC, Racing	BTL09A120C		
KTM	2003	MX Desert Racing	BTL09A120C		
KTM	2000-2002	E/XC, M/XC Racing 4-Stroke	BTL09A120C		
KTM	2000-2002	E/XC Racing 4-Stroke	BTL09A120C		
KTM	1999-2002	Adventurer, Duke, RXC LC4 Super Moto	BTL09A120C BTL14A240C		
KTM	1996-2001	RXC LC4	BTL09A120C BTL14A240C		
KTM	2000	MXC Racing	BTL09A120C		
KTM	1996-1998	Adventure, Duke, LC4	BTL09A120C BTL14A240C		
KTM	1996-1998	LC4 E/XC	BTL09A120C BTL14A240C		
Kymco	2009-2010	Venox250	BTL14A240C		
Moto Guzzi	2013	California	BTL18A300C BTL24A360C BTL35A480C		
Moto Guzzi	2012-2013	V7	BTL14A240C		
Moto Guzzi	2009-2013	1200 Sport	No Equivalent		
Moto Guzzi	2005-2013	1100 California, Special, Jackal, Breva, Griso	No Equivalent		
Moto Guzzi	2010-2012	California Classic, Vintage	BTL18A300C BTL24A360C BTL35A480C		
Moto Guzzi	2009-2012	Norge	No Equivalent		
Moto Guzzi	2009-2012	Stervio	No Equivalent		
Moto Guzzi	2009-2011	V7 Classic	BTL14A240C		
Moto Guzzi	1933-2011	1000NT	BTL35A480C		
Moto Guzzi	1933-2011	Convert	BTL35A480C		
Moto Guzzi	1933-2011	Daytona	BTL35A480C		

MAKE	YEAR/YEARS	MODEL	PART#	UPGRADE1	UPGRADE2
Moto Guzzi	1933-2011	Falcone	No Equivalent		
Moto Guzzi	1933-2011	Falcone u.t.	BTL18A300C BTL24A360C BTL35A480C		
Moto Guzzi	1933-2011	Le Man	BTL35A480C		
Moto Guzzi	1933-2011	Le Mans	BTL35A480C		
Moto Guzzi	1933-2011	Mille	BTL35A480C		
Moto Guzzi	1933-2011	Nevada	BTL18A300C BTL24A360C BTL35A480C		
Moto Guzzi	1933-2011	NTX 750cc	BTL18A300C BTL24A360C BTL35A480C		
Moto Guzzi	1933-2011	NTX 650cc	BTL18A300C BTL24A360C BTL35A480C		
Moto Guzzi	1933-2011	Quota	BTL35A480C		
Moto Guzzi	1933-2011	Strada	BTL18A300C BTL24A360C BTL35A480C		
Moto Guzzi	1933-2011	T3, T4, T5	BTL35A480C		
Moto Guzzi	1933-2011	V50	BTL35A480C		
Moto Guzzi	1933-2011	V65	BTL35A480C		
Moto Guzzi	1933-2011	V65 Florida	BTL18A300C BTL24A360C BTL35A480C		
Moto Guzzi	1933-2011	V7	BTL35A480C		
Moto Guzzi	1933-2011	V75	BTL18A300C BTL24A360C BTL35A480C		
Moto Guzzi	2009-2010	Breva 1200	No Equivalent		
Moto Guzzi	2009-2010	Sport, ABS	No Equivalent		
Moto Guzzi	2004-2010	Breva 750	BTL14A240C		
Moto Guzzi	1933-2010	Bellagio	BTL18A300C BTL24A360C BTL35A480C		
Moto Guzzi	1933-2010	Nevada 750 Classic	BTL14A240C		
Moto Guzzi	2003-2005	1100 1100 California (CA only)	BTL14A240C		
Moto Guzzi	1999-2005	V11 Le Mans, Sport	BTL14A240C		
Moto Guzzi	1994-2005	Stone, EV	BTL35A480C		
Moto Guzzi	1999-2002	Quota 1100 ES	BTL14A240C		
Moto Guzzi	1999-2000	V11 Bassa	BTL35A480C		
Moto Guzzi	1990	V10 Centauro Sport, GT	BTL14A240C		
Moto Guzzi	1989-1999	V11 EV	BTL35A480C		
Moto Guzzi	1997-1999	Sport 1100i	BTL14A240C		
Moto Guzzi	1989-1993	California III	BTL35A480C		
Muz	1933-2011	All Models All Years	BTL14A240C		
Muz	1995-2001	Skorpion '95-'01	BTL14A240C		
MV Agusta	2013	Brutale 800cc	BTL14A240C		
MV Agusta	2013	F3, Brutale	BTL14A240C		
MV Agusta	2009-2013	Brutale 1078RR, 1090	BTL14A240C		
MV Agusta	2005-2013	F4	BTL14A240C		
MV Agusta	2006-2009	Brutale 910cc	BTL14A240C		
MV Agusta	2000-2008	F4, Brutale	BTL14A240C		
Norton	1933-2011	Commando, Commando (75)	BTL14A240C		
Norton	1933-2011	Ranger Commando	BTL09A120C BTL14A240C		
Polaris Victory	2008-2013	Vegas Jackpot, Hammer, Ness, Vision,	BTL18A300C BTL24A360C BTL35A480C		
Polaris Victory	2006-2010	Vegas, Kingpin, Hammer(-08)	BTL18A300C BTL24A360C BTL35A480C		
Polaris Victory	2002-2006	V92TC Touring Cruiser	BTL18A300C BTL24A360C BTL35A480C		
Polaris Victory	2003-2005	Vegas, Kingpin, Hammer	BTL18A300C BTL24A360C BTL35A480C		
Polaris Victory	1998-2004	V92C, DC Classic, Deluxe Cruiser	BTL18A300C BTL24A360C BTL35A480C		
Polaris Victory	2000-2001	V92SC Sport Cruiser	BTL18A300C BTL24A360C BTL35A480C		
Puch	1933-2011	Cobra 80	No Equivalent		
Puch	1933-2011	Cobra GTL, Daytona N50, Monza	No Equivalent		
Puch	1933-2011	Lido SL50, Lido Vario	BTL09A120C		
Puch	1933-2011	Monza GP, Monza GX, Monza X	No Equivalent		

MAKE	YEAR/YEARS	MODEL	PART#	UPGRADE1	UPGRADE2
Royal Enfield	2000-2003	All Electric Start Models 500cc	BTL14A240C		
Royal Enfield	2000-2003	All Electric Start Models 350cc	BTL14A240C		
Royal Enfield	2000-2003	All Kick-start Models 500cc	BTL09A120C		
Royal Enfield	2000-2003	All Kick-start Models 350cc	BTL09A120C		
Royal Enfield	1995-1999	All Kick-start Models 500cc	BTL09A120C	BTL14A240C	
Royal Enfield	1995-1999	All Kick-start Models 350cc	BTL09A120C	BTL14A240C	
Suzuki	2009-2013	TU250X	BTL09A120C		
Suzuki	2009-2013	VZ1500 Boulevard M90	No Equivalent		
Suzuki	2008-2013	GSX1300R, Z Hayabusa	BTL14A240C		
Suzuki	2008-2013	SV650, S	BTL14A240C		
Suzuki	2007-2013	GSX1250S, A Bandit, FA	BTL14A240C		
Suzuki	2006-2013	VZR1800 (M109R)	No Equivalent		
Suzuki	2005-2013	GSX-R1000	BTL14A240C		
Suzuki	2004-2013	DL650 V-Strom ABS, Adventure	BTL14A240C		
Suzuki	2002-2013	DL1000 V-Strom, Adventure	BTL14A240C		
Suzuki	2001-2013	VL800 Intruder Volusia, Boulevard C50, T, M50	BTL14A240C		
Suzuki	2000-2013	DR-Z400, E, S, SM	BTL09A120C	BTL14A240C	
Suzuki	2000-2013	GSX-R750	BTL14A240C		
Suzuki	1998-2013	DR650SE	BTL09A120C	BTL14A240C	
Suzuki	1997-2013	GSX-R600	BTL09A120C	BTL14A240C	
Suzuki	1996-2013	DR200SE	BTL09A120C		
Suzuki	1986-2013	LS650 Savage, S40	BTL14A240C		
Suzuki	2008-2012	VLR1800 (C109R)	No Equivalent		
Suzuki	1999-2012	GZ250	BTL09A120C		
Suzuki	1992-2012	VS800 GL, S Intruder, Boulevard S50	BTL14A240C		
Suzuki	2009-2011	SFV650 Gladius	BTL14A240C		
Suzuki	2008-2011	GSX1300BK B-King	BTL14A240C		
Suzuki	2008-2011	GSX650F	BTL09A120C	BTL14A240C	
Suzuki	2001-2011	GS500, F	BTL14A240C		
Suzuki	1998-2011	VL1500 Intruder, Boulevard C90	BTL14A240C		
Suzuki	1987-2011	VS1400GL Intruder, GLP, S83	BTL14A240C		
Suzuki	1933-2011	B100P	No Equivalent		
Suzuki	1933-2011	B105P	No Equivalent		
Suzuki	1933-2011	B120P	No Equivalent		
Suzuki	1933-2011	T200, TC200	BTL09A120C		
Suzuki	1933-2011	TC90	No Equivalent		
Suzuki	1933-2011	TC90J, TC90R	No Equivalent		
Suzuki	2003-2010	SV650A, SA	BTL14A240C		
Suzuki	2008-2009	DR-Z70	No Equivalent		
Suzuki	1997-2008	VZ800 Marauder	BTL14A240C		
Suzuki	2003-2007	SV1000, S	BTL14A240C		
Suzuki	2001-2007	DR-Z250	No Equivalent		
Suzuki	1999-2007	GSX1300R Hayabusa	BTL14A240C		
Suzuki	1998-2006	GSX600F Katana	BTL09A120C	BTL14A240C	
Suzuki	1998-2006	GSX750F Katana	BTL09A120C	BTL14A240C	
Suzuki	2004-2005	Marauder, Boulevard M95	BTL14A240C		
Suzuki	1997-2005	GSF1200, S Bandit	BTL14A240C		
Suzuki	2001-2004	GSX-R1000	BTL14A240C		
Suzuki	1998-2003	TL1000R	BTL14A240C		
Suzuki	1996-2003	GSF600S Bandit	BTL09A120C	BTL14A240C	

MAKE	YEAR/YEARS	MODEL	PART#	UPGRADE1	UPGRADE2
Suzuki	1999-2002	SV650	BTL14A240C		
Suzuki	1997-2001	TL1000S	BTL14A240C		
Suzuki	1981-2001	GSX1100S Katana	BTL14A240C		
Suzuki	1989-2000	GS500E	BTL14A240C		
Suzuki	1996-1999	GSX-R750	BTL09A120C	BTL14A240C	
Suzuki	1994-1999	DR350SE	BTL09A120C		
Suzuki	1993-1998	GSX-R1100 W	BTL14A240C		
Suzuki	1996-1997	DR650SE (CN)	BTL09A120C	BTL14A240C	
Suzuki	1996-1997	DR650SE	BTL14A240C		
Suzuki	1994-1997	RF900, R, S, ZS	BTL09A120C	BTL14A240C	
Suzuki	1989-1997	GSX750F Katana	BTL14A240C		
Suzuki	1988-1997	GSX600F Katana	BTL14A240C		
Suzuki	1994-1996	RF600R, S	BTL09A120C	BTL14A240C	
Suzuki	1994-1996	DR125, SE, SES	BTL09A120C		
Suzuki	1991-1996	GN125, E	BTL09A120C	BTL14A240C	
Suzuki	1990-1996	DR350S	BTL09A120C		
Suzuki	1994-1995	DR650S ER, ES	BTL14A240C		
Suzuki	1994-1995	GSXR750W	BTL09A120C	BTL14A240C	
Suzuki	1993-1995	DR250S EP, ER, ES	BTL09A120C		
Suzuki	1994	RV125 SE, R	BTL09A120C		
Suzuki	1993	GSXR750W	BTL14A240C		
Suzuki	1992-1993	DR650S N, P	BTL09A120C		
Suzuki	1992-1993	GSX-R600W	BTL09A120C	BTL14A240C	
Suzuki	1991-1993	GSF400 Bandit	BTL09A120C	BTL14A240C	
Suzuki	1991-1993	GSX1100G	BTL14A240C		
Suzuki	1990-1993	VX800	BTL14A240C		
Suzuki	1988-1993	GSX1100F Katana	BTL14A240C		
Suzuki	1990-1992	DR250S	BTL09A120C		
Suzuki	1986-1992	GSX-R1100	BTL14A240C		
Suzuki	1986-1992	GSX-R750	BTL14A240C		
Suzuki	1990-1991	DR650S	BTL09A120C		
Suzuki	1988-1991	VS750GLP Intruder	BTL14A240C		
Suzuki	1986-1988	SP125	No Equivalent		
Suzuki	1986-1988	SP200	BTL09A120C		
Suzuki	1986-1988	GV1400GC, D, T Cavalcade	BTL24A360C	BTL35A480C	
Suzuki	1983-1988	GS450	BTL14A240C		
Suzuki	1982-1988	GN250	BTL14A240C		
Suzuki	1985-1987	VS700GL Intruder	BTL14A240C		
Suzuki	1985-1986	GV1200GL Madura	BTL14A240C		
Suzuki	1983-1986	GS1150E, S	BTL14A240C		
Suzuki	1983-1986	GS550E, ES, L	BTL14A240C		
Suzuki	1985	GS700E, GS700ES	BTL14A240C		
Suzuki	1985	GV700GL Madura	BTL14A240C		
Suzuki	1985	SP600	BTL09A120C		
Suzuki	1982-1985	GS300L	BTL14A240C		
Suzuki	1982-1985	SP250	No Equivalent		
Suzuki	1982-1984	GS1100G, K, L, Katana	BTL14A240C		
Suzuki	1983	GR650 Tempter, X	BTL14A240C		
Suzuki	1983	SP100	No Equivalent		
Suzuki	1983	XN85 Turbo	BTL14A240C		

MAKE	YEAR/YEARS	MODEL	PART#	UPGRADE1	UPGRADE2
Suzuki	1982-1983	GN125, E	BTL09A120C	BTL14A240C	
Suzuki	1982-1983	SP125	No Equivalent		
Suzuki	1981-1983	GS650 (All)	BTL14A240C		
Suzuki	1981-1983	SP500	No Equivalent		
Suzuki	1980-1983	GS1100E, S	BTL14A240C		
Suzuki	1979-1983	GS850G, GL	BTL14A240C		
Suzuki	1977-1983	GS750, Katana	BTL14A240C		
Suzuki	1981-1982	GS650E	BTL14A240C		
Suzuki	1980-1982	GN400T, X	No Equivalent		
Suzuki	1980-1982	GS450	BTL14A240C		
Suzuki	1978-1982	GS1000	BTL14A240C		
Suzuki	1977-1982	GS550E, L, M, TX	BTL14A240C		
Suzuki	1980-1981	GS250T	BTL14A240C		
Suzuki	1978-1981	TS100 Honcho	No Equivalent		
Suzuki	1977-1981	TS185 Sierra	No Equivalent		
Suzuki	1973-1981	TS250 Savage	No Equivalent		
Suzuki	1971-1981	TS125 Duster	No Equivalent		
Suzuki	1980	SP400	No Equivalent		
Suzuki	1979-1980	OR50	No Equivalent		
Suzuki	1979	GS425, GS425E, L	BTL14A240C		
Suzuki	1979	T350 Series	BTL09A120C		
Suzuki	1978-1979	SP370	No Equivalent		
Suzuki	1977-1978	GS400	BTL14A240C		
Suzuki	1977-1978	GS400X	BTL09A120C	BTL14A240C	
Suzuki	1976-1977	A100 Go-fer	No Equivalent		
Suzuki	1976-1977	GT500 Titan	BTL09A120C	BTL14A240C	
Suzuki	1976-1977	TS400 Apache	No Equivalent		
Suzuki	1975-1977	TS75 Colt	No Equivalent		
Suzuki	1974-1977	TC185 Ranger	BTL09A120C	BTL14A240C	
Suzuki	1973-1977	GT185 Adventurer	BTL09A120C	BTL14A240C	
Suzuki	1973-1977	GT250 Hustler	BTL09A120C		
Suzuki	1973-1977	RV125 Tracker	No Equivalent		
Suzuki	1973-1977	RV90 Rover	No Equivalent		
Suzuki	1973-1977	TC100 Blazer	No Equivalent		
Suzuki	1973-1977	TS100 Honcho	No Equivalent		
Suzuki	1973-1977	TC125 Prospector	No Equivalent		
Suzuki	1972-1977	GT380 Sebring	BTL09A120C	BTL14A240C	
Suzuki	1972-1977	GT550 Indy	BTL09A120C	BTL14A240C	
Suzuki	1972-1977	GT750 LeMans	BTL14A240C		
Suzuki	1971-1976	TS185 Sierra	No Equivalent		
Suzuki	1972-1975	TS400 Apache	BTL09A120C		
Suzuki	1968-1975	T500 Titan	BTL09A120C	BTL14A240C	
Suzuki	1974	TS50	No Equivalent		
Suzuki	1972	RV90 Rover	No Equivalent		
Suzuki	1972	T250, T250-II, T250J, T250R	BTL09A120C		
Suzuki	1969-1972	TS250 Savage	No Equivalent		
Suzuki	1971	AC50, AS50	No Equivalent		
Suzuki	1971	TC120, TC120-II, TC120R	No Equivalent		
Suzuki	1969	A100 Go-fer	No Equivalent		
Suzuki	1969	Model T20	BTL09A120C		

MAKE	YEAR/YEARS	MODEL	PART#	UPGRADE1	UPGRADE2
Suzuki	1969	Scramble TC305	BTL09A120C		
Suzuki	1969	Scrambler AC100	No Equivalent		
Suzuki	1969	Scrambler TC250	BTL09A120C		
Suzuki	1969	Sport AS100	No Equivalent		
Suzuki	1969	T305	BTL09A120C		
Suzuki	1968	Model 31	No Equivalent		
Suzuki	1968	Model K10, Model K10P	No Equivalent		
Suzuki	1968	Sport 50 (Model M12)	No Equivalent		
Suzuki	1968	Sport 80 (Models K11 & K11P)	No Equivalent		
Suzuki	1968	Trail 80 (Models K15 & K15P)	No Equivalent		
Triumph	2011-2013	Bonneville, T100, SE, FI (No Equivalent)	BTL14A240C		
Triumph	2011-2013	Scrambler	BTL14A240C		
Triumph	2011-2013	Tiger 800cc	BTL14A240C		
Triumph	2010-2013	Thunderbird	BTL18A300C	BTL24A360C	BTL35A480C
Triumph	2009-2013	America	BTL14A240C		
Triumph	2009-2013	Speedmaster	BTL14A240C		
Triumph	2009-2013	Thrupton	BTL14A240C		
Triumph	2009-2013	Street Triple, R	BTL09A120C	BTL14A240C	
Triumph	2008-2013	Daytona 675, R	BTL09A120C	BTL14A240C	
Triumph	2007-2013	Tiger 1050cc	BTL14A240C		
Triumph	2005-2013	Speed Triple, R	BTL14A240C		
Triumph	2003-2013	Rocket III	BTL18A300C	BTL24A360C	BTL35A480C
Triumph	1933-2011	350 (12V)	No Equivalent		
Triumph	1933-2011	350 3TA, Twenty One	No Equivalent		
Triumph	1933-2011	500 (12V)	No Equivalent		
Triumph	1933-2011	600 (12V)	No Equivalent		
Triumph	1933-2011	Bonneville, Tiger	BTL09A120C	BTL14A240C	
Triumph	1933-2011	T120 Bonneville	BTL09A120C	BTL14A240C	
Triumph	1933-2011	T150 Trident	BTL09A120C	BTL14A240C	
Triumph	2008-2010	Bonneville, T100, SE, FI	BTL14A240C		
Triumph	2008-2010	Scrambler	BTL14A240C		
Triumph	2005-2010	Speed Triple	BTL14A240C		
Triumph	2003-2008	Thrupton	BTL14A240C		
Triumph	2006-2007	Daytona 675, R	BTL09A120C	BTL14A240C	
Triumph	2006-2007	Scrambler, Bonneville	BTL14A240C		
Triumph	2005-2007	Bonneville, T100, SE,	BTL14A240C		
Triumph	2005-2007	Scrambler	BTL14A240C		
Triumph	2005-2006	Tiger 955cc	BTL14A240C		
Triumph	2003-2005	Daytona 600/650, Speed Four	BTL09A120C	BTL14A240C	
Triumph	2003-2005	Speedmaster	BTL14A240C		
Triumph	2001-2005	Bonneville	BTL14A240C		
Triumph	2000-2004	Sprint RS	BTL14A240C		
Triumph	2000-2004	Trophy	BTL14A240C		
Triumph	1999-2004	Daytona 955i, Speed Triple, Sprint ST	BTL14A240C		
Triumph	2002-2003	Thunderbird	BTL14A240C		
Triumph	2000-2003	TT600	BTL14A240C		
Triumph	1999-2001	Tiger 900cc	BTL14A240C		
Triumph	1991-2001	All Other Models	BTL14A240C		
Triumph	1993-1999	All Other Models	BTL14A240C		
Triumph	1996-1997	All Other Models	BTL14A240C		

MAKE	YEAR/YEARS	MODEL	PART#	UPGRADE1	UPGRADE2
Triumph	1993-1997	All Other Models	BTL14A240C		
Triumph	1992-1993	Daytona	BTL14A240C		
Yamaha	2011-2013	FZ8	BTL14A240C		
Yamaha	2011-2013	XT1200Z Super Tenere	BTL14A240C		
Yamaha	2010-2013	SR400 (FI)	No Equivalent		
Yamaha	2009-2013	VMAX	BTL14A240C		
Yamaha	2009-2013	XJ6, Deversion (EU)	BTL14A240C		
Yamaha	2009-2013	XV250YCR V Star 250	BTL14A240C		
Yamaha	2009-2013	XVS13AY V Star 1300, Stryker	BTL18A300C	BTL24A360C	BTL35A480C
Yamaha	2008-2013	WR250X, R	No Equivalent		
Yamaha	2008-2013	XT250	No Equivalent		
Yamaha	2008-2013	XV17AT Road Star, Silverado	BTL14A240C		
Yamaha	2007-2013	XJR1300 (EU)	BTL14A240C		
Yamaha	2006-2013	FZS1000 FZ1	BTL14A240C		
Yamaha	2006-2013	MT-03 (EU)	BTL09A120C	BTL14A240C	
Yamaha	2006-2013	Roadliner, Raider, Stratoliner	BTL14A240C		
Yamaha	2006-2013	YZF-R6 (Excl. R6S)	BTL14A240C		
Yamaha	2005-2013	FZ6, R	BTL14A240C		
Yamaha	2005-2013	XT250 Serow	No Equivalent		
Yamaha	2004-2013	XT660X,R,Z, Tenere (EU)	BTL09A120C	BTL14A240C	
Yamaha	2004-2013	YZF-R1	BTL14A240C		
Yamaha	2003-2013	FJR1300, A	BTL14A240C		
Yamaha	2003-2013	TDM900 (EU)	BTL14A240C		
Yamaha	1998-2013	XVS650 V-Star (All)	BTL14A240C		
Yamaha	1987-2013	TW200	BTL09A120C		
Yamaha	2009-2012	XVS95CT,Y V Star 950, Tourer	BTL14A240C		
Yamaha	2005-2012	MT-01 (EU)	BTL14A240C		
Yamaha	1996-2012	XVZ13 Royal Star/Venture (All)	BTL18A300C	BTL24A360C	BTL35A480C
Yamaha	2010-2011	Tricker	No Equivalent		
Yamaha	1999-2010	XVS1100 V-Star (All)	BTL14A240C		
Yamaha	1933-2010	SRX600	BTL14A240C		
Yamaha	2008-2009	WR250F	No Equivalent		
Yamaha	2001-2009	SR400	No Equivalent		
Yamaha	2002-2008	XV17P Road Star Warrior	BTL14A240C		
Yamaha	2006-2007	TTR230E	BTL09A120C		
Yamaha	2006-2007	TTR50E	No Equivalent		
Yamaha	2004-2007	XV17AT Road Star, Silverado	BTL18A300C	BTL24A360C	BTL35A480C
Yamaha	2003-2007	TTR125E/LE Electric Start	BTL09A120C		
Yamaha	2003-2007	TTR90E Electric Start	No Equivalent		
Yamaha	2003-2007	WR250F	BTL09A120C		
Yamaha	2003-2007	WR450F	No Equivalent		
Yamaha	2001-2007	XT225	No Equivalent		
Yamaha	2001-2007	YZF-R6, R6S	BTL09A120C	BTL14A240C	
Yamaha	1995-2007	YZF600R	BTL14A240C		
Yamaha	1985-2007	VMX12 V-Max	BTL14A240C		
Yamaha	1999-2006	TTR250	BTL09A120C	BTL14A240C	
Yamaha	2001-2005	FZS1000 FZ1	BTL14A240C		
Yamaha	1999-2005	TTR225	BTL09A120C		
Yamaha	1999-2003	XV1600 Road Star	BTL18A300C	BTL24A360C	BTL35A480C
Yamaha	1999-2003	YZF-R1	BTL14A240C		

MAKE	YEAR/YEARS	MODEL	PART#	UPGRADE1	UPGRADE2
Yamaha	1995-2003	XV250 Virago	BTL14A240C		
Yamaha	1999-2000	YZF-R6	BTL14A240C		
Yamaha	1992-2000	XT225 Serow	BTL09A120C		
Yamaha	1985-2000	XT350	No Equivalent		
Yamaha	1978-2000	SR400	BTL09A120C	BTL14A240C	
Yamaha	1999	YZF-R7	BTL09A120C	BTL14A240C	
Yamaha	1995-1999	TRX850	BTL14A240C		
Yamaha	1989-1999	FZR600/R	BTL14A240C		
Yamaha	1987-1999	XV535 Virago	BTL14A240C		
Yamaha	1986-1999	XV1100 Virago (All)	BTL24A360C	BTL35A480C	
Yamaha	1978-1999	SR500	BTL09A120C	BTL14A240C	
Yamaha	1997-1998	YZF1000R	BTL14A240C		
Yamaha	1994-1998	YZF750R	BTL14A240C		
Yamaha	1992-1998	XJ600S Seca II	BTL09A120C	BTL14A240C	
Yamaha	1981-1996	XV750 Virago (All)	BTL14A240C		
Yamaha	1991-1995	FZR1000	BTL14A240C		
Yamaha	1990-1995	XT600E	BTL09A120C	BTL14A240C	
Yamaha	1993-1994	GTS1000	BTL14A240C		
Yamaha	1992-1993	TDM850	BTL14A240C		
Yamaha	1991-1993	FJ1200 (All)	BTL14A240C		
Yamaha	1986-1993	XVZ13 Venture/Royale	BTL24A360C	BTL35A480C	
Yamaha	1988-1990	DT50 Enduro	No Equivalent		
Yamaha	1988-1990	FZR400 (All)	BTL14A240C		
Yamaha	1988-1990	XV250 Route 66	BTL14A240C		
Yamaha	1987-1990	FZR1000	BTL14A240C		
Yamaha	1986-1990	FJ1200	BTL14A240C		
Yamaha	1986-1990	YX600 Radian	BTL09A120C	BTL14A240C	
Yamaha	1984-1989	XT600	BTL09A120C		
Yamaha	1987-1988	BW350 Big Wheel	BTL14A240C		
Yamaha	1986-1988	BW200E Big Wheel (Electric Start)	BTL09A120C		
Yamaha	1986-1988	FZ600	BTL09A120C	BTL14A240C	
Yamaha	1985-1988	FZ750, FZR750	BTL14A240C		
Yamaha	1987	SRX250	BTL09A120C	BTL14A240C	
Yamaha	1986-1987	FZ700, Fazer	BTL14A240C		
Yamaha	1984-1987	XV700 Virago	BTL14A240C		
Yamaha	1985-1986	XJ700 Maxim, XJ700X	BTL14A240C		
Yamaha	1984-1985	FJ1100	BTL14A240C		
Yamaha	1984-1985	FJ600	BTL09A120C	BTL14A240C	
Yamaha	1984-1985	RZ350	BTL09A120C		
Yamaha	1984-1985	XV1000 Virago	BTL24A360C	BTL35A480C	
Yamaha	1983-1985	XVZ12 Venture/Royale	BTL24A360C	BTL35A480C	
Yamaha	1984	XT250	No Equivalent		
Yamaha	1983	XJ750M Midnight Maxim	BTL14A240C		
Yamaha	1983	XJ900R Seca	BTL14A240C		
Yamaha	1983	XV500 Virago	BTL09A120C	BTL14A240C	
Yamaha	1983	XV920M Midnight Virago	BTL24A360C	BTL35A480C	
Yamaha	1982-1983	XJ750 Maxim	BTL14A240C		
Yamaha	1982-1983	XT550	BTL09A120C		
Yamaha	1982-1983	XZ550R Vision	BTL14A240C		
Yamaha	1981-1983	XJ550 Maxim, R Seca	BTL09A120C	BTL14A240C	

MAKE	YEAR/YEARS	MODEL	PART#	UPGRADE1	UPGRADE2
Yamaha	1981-1983	XJ750R Seca	BTL14A240C		
Yamaha	1981-1983	XV920R Virago	BTL24A360C	BTL35A480C	
Yamaha	1980-1983	XJ650 (All)	BTL09A120C	BTL14A240C	
Yamaha	1980-1983	XS400 (All)	BTL09A120C	BTL14A240C	
Yamaha	1975-1983	XS650	BTL14A240C		
Yamaha	1982	XJ1100 Maxim	BTL24A360C	BTL35A480C	
Yamaha	1982	XV920 Virago	BTL24A360C	BTL35A480C	
Yamaha	1981-1982	SR185 Exciter	BTL09A120C	BTL14A240C	
Yamaha	1980-1982	SR250 Exciter	BTL09A120C	BTL14A240C	
Yamaha	1980-1981	XS850 (All)	BTL14A240C		
Yamaha	1978-1981	XS1100 (All)	BTL24A360C	BTL35A480C	
Yamaha	1974-1981	DT125 Enduro	BTL09A120C	BTL14A240C	
Yamaha	1977-1979	XS750 (All)	BTL14A240C		
Yamaha	1976-1979	RD400	BTL09A120C		
Yamaha	1976-1978	XS360	BTL09A120C	BTL14A240C	
Yamaha	1975-1978	XS500	BTL14A240C		
Yamaha	1977	XS360-2	BTL09A120C	BTL14A240C	
Yamaha	1975-1976	DT400 Enduro	No Equivalent		
Yamaha	1975-1976	RD125	BTL09A120C		
Yamaha	1974-1976	DT100 Enduro	No Equivalent		
Yamaha	1974-1976	DT175 Enduro	No Equivalent		
Yamaha	1974-1976	DT250 Enduro	No Equivalent		
Yamaha	1974-1976	RD200	BTL14A240C		
Yamaha	1973-1975	RD250	BTL09A120C		
Yamaha	1973-1975	RD350	BTL09A120C		
Yamaha	1974	DT360 Enduro	No Equivalent		
Yamaha	1974	TX650	BTL14A240C		
Yamaha	1973-1974	TX500	BTL14A240C		
Yamaha	1973-1974	TX750	BTL18A300C	BTL24A360C	BTL35A480C
Yamaha	1973	TX650	BTL09A120C	BTL14A240C	
Yamaha	1972-1973	AT2, AT3 125 Enduro	BTL09A120C	BTL14A240C	
Yamaha	1972	CS5	BTL14A240C		
Yamaha	1972	DS7	BTL09A120C		
Yamaha	1972	JT2 Mini Enduro	No Equivalent		
Yamaha	1972	LS2	BTL09A120C		
Yamaha	1972	XS2	BTL09A120C	BTL14A240C	
Yamaha	1970-1972	R5, R5B, R5C	BTL09A120C		
Yamaha	1970-1971	CS3B, CS3C	BTL14A240C		
Yamaha	1970-1971	HS1, HS1B	BTL09A120C		
Yamaha	1970-1971	HT1, HT1B 90 Enduro	No Equivalent		
Yamaha	1970-1971	RT1, RT1B 360 Enduro	No Equivalent		
Yamaha	1970-1971	XS1	BTL09A120C		
Yamaha	1969-1971	AT1E, AT1B, AT1C 125 Enduro	BTL09A120C	BTL14A240C	
Yamaha	1969-1971	CT1, CT1B, CT1C 175 Enduro	No Equivalent		
Yamaha	1969-1971	DT1B, DT1C, DT1E 250 Enduro	No Equivalent		
Yamaha	1969-1970	DS6B, DS6C	BTL09A120C		
Yamaha	1969-1970	L5T, L5TA	BTL09A120C	BTL14A240C	
Yamaha	1969	AS2C	BTL09A120C		
Yamaha	1969	R3	BTL09A120C		
Yamaha	1968-1969	YG5T, YG5S	BTL09A120C	BTL14A240C	

MAKE	YEAR/YEARS	MODEL	PART#	UPGRADE1	UPGRADE2
Yamaha	1968	DT1 250 Enduro	No Equivalent		
Yamaha	1968	YAS1/C	BTL09A120C		
Yamaha	1968	YCS1	BTL14A240C		
Yamaha	1968	YL2C/CM	BTL09A120C	BTL14A240C	
Yamaha	1968	YR2/C	BTL09A120C		
Yamaha	1964-1966	YA6	BTL14A240C		

ATVs

Aeon (Benzai)	1933-2012	Cobra/CX-Sport 100	BTL09A120C		
Aeon (Benzai)	1933-2012	Cobra/CX-Sport 90	BTL09A120C		
Aeon (Benzai)	1933-2012	Cobra/CX-Sport 50	BTL09A120C		
Arctic Cat	2013	90	BTL09A120C		
Arctic Cat	2013	CORE, XT	BTL24A360C	BTL35A480C	
Arctic Cat	2010-2013	150	BTL09A120C	BTL14A240C	
Arctic Cat	2010-2013	550, TRV, LTD, S, XT, CORE	BTL24A360C	BTL35A480C	
Arctic Cat	2010-2013	Mudpro 1000H2, TRV, 1000i GT, XT	BTL24A360C	BTL35A480C	
Arctic Cat	2009-2013	DVX300, Utility	BTL14A240C		
Arctic Cat	2009-2013	TRV, Mudpro, LTD, TBX, Diesel	BTL24A360C	BTL35A480C	
Arctic Cat	2006-2013	DVX90	BTL09A120C		
Arctic Cat	2011-2012	450, TRV, CORE	BTL24A360C	BTL35A480C	
Arctic Cat	2008-2012	366	BTL14A240C		
Arctic Cat	2005-2012	650H1, TBX650, Mudpro	BTL14A240C		
Arctic Cat	1933-2011	All Models 500cc	BTL14A240C		
Arctic Cat	1933-2011	All Models 400cc	BTL14A240C		
Arctic Cat	1933-2011	All Models 300cc	BTL14A240C		
Arctic Cat	1933-2011	DVX 400	BTL09A120C	BTL14A240C	
Arctic Cat	2009-2010	Thundercat	BTL24A360C	BTL35A480C	
Arctic Cat	2009-2010	TRV 400	BTL14A240C		
Arctic Cat	2006-2010	DVX50	BTL09A120C		
Arctic Cat	1933-2010	250	BTL14A240C		
Arctic Cat	2006-2008	700	BTL14A240C		
Arctic Cat	2006	All Models 90cc	BTL09A120C		
Arctic Cat	2006	DVX250, 2x4	BTL14A240C		
Arctic Cat	2004-2006	4x4 Automatic	BTL14A240C		
Arctic Cat	2005	All Models	BTL14A240C		
Bombardier (Can-Am)	2012-2013	Outlander 1000, Renegade	BTL24A360C	BTL35A480C	
Bombardier (Can-Am)	2010-2013	DS70	BTL09A120C		
Bombardier (Can-Am)	2009-2013	DS450	BTL09A120C	BTL14A240C	
Bombardier (Can-Am)	2009-2013	Outlander, MAX	BTL24A360C	BTL35A480C	
Bombardier (Can-Am)	2009-2013	Outlander, MAX, Renegade	BTL24A360C	BTL35A480C	
Bombardier (Can-Am)	2006-2013	DS250	BTL14A240C		
Bombardier (Can-Am)	2006-2013	Outlander 800 EFI, MAX, Renegade	BTL24A360C	BTL35A480C	
Bombardier (Can-Am)	2004-2013	Outlander 400, XT, MAX	BTL24A360C	BTL35A480C	
Bombardier (Can-Am)	2002-2013	DS90, DS90F, Quest	BTL09A120C		
Bombardier (Can-Am)	2006	Outlander 660 EFI	BTL24A360C	BTL35A480C	
Bombardier (Can-Am)	2002-2006	DS50, Quest	BTL09A120C		
Bombardier (Can-Am)	2002-2006	Rally	BTL14A240C		
Bombardier (Can-Am)	2000-2006	DS650	BTL14A240C		
Bombardier (Can-Am)	2004-2005	Outlander 330	BTL14A240C		
Bombardier (Can-Am)	2002-2005	Quest	BTL24A360C	BTL35A480C	
Bombardier (Can-Am)	2002-2005	Traxter (All Models), Quest (Opt)	BTL24A360C	BTL35A480C	

MAKE	YEAR/YEARS	MODEL	PART#	UPGRADE1	UPGRADE2
Bombardier (Can-Am)	1999-2005	Traxter (All Models), Quest	BTL24A360C	BTL35A480C	
Bombardier (Can-Am)	2003-2004	Outlander 400	BTL14A240C		
E-Ton	2010-2013	Vector250	BTL14A240C		
E-Ton	2010-2013	Viper 70	BTL09A120C		
E-Ton	2010-2013	Viper150R	BTL09A120C	BTL14A240C	
E-Ton	2004-2013	All models 90cc	BTL09A120C		
E-Ton	2000-2013	CXL150 Yukon II	BTL09A120C	BTL14A240C	
E-Ton	2004-2005	All models 50cc	BTL09A120C		
E-Ton	2000-2003	YXL150 Yukon	BTL09A120C	BTL14A240C	
E-Ton	1999-2003	AXL, TXL, NXL, RXL 90cc	BTL09A120C		
E-Ton	1999-2003	AXL, TXL, NXL, RXL 50cc	BTL09A120C		
E-Ton	1999-2003	DXL90 Sierra	BTL09A120C		
Honda	2011-2013	TRX500FE, FPE, FM, FPM	BTL14A240C		
Honda	2009-2013	TRX420 Fourtrax Rancher 4x4	BTL14A240C		
Honda	2008-2013	TRX700XX	BTL09A120C	BTL14A240C	
Honda	2006-2013	TRX450ER, TRX450R	No Equivalent		
Honda	2006-2013	TRX680FA Four Trax Rincon	BTL24A360C	BTL35A480C	
Honda	2006-2013	TRX90X, EX	BTL09A120C		
Honda	2001-2013	TRX250X, EX,	BTL09A120C	BTL14A240C	
Honda	1999-2013	TRX400X, EX, Fourtrax, Sportrax	BTL09A120C	BTL14A240C	
Honda	1997-2013	TRX250 TE, TM, FourTrax Recon	BTL14A240C		
Honda	1993-2012	TRX300X, EX	BTL09A120C	BTL14A240C	
Honda	2005-2011	TRX500FE, FM, TM Trax Foreman	BTL14A240C		
Honda	2001-2011	TRX500FA Fourtrax Rubicon	BTL14A240C		
Honda	2005-2009	FourTrax Foreman ES, 4x4	BTL14A240C		
Honda	2004-2006	TRX400 Rancher AT	BTL14A240C		
Honda	2000-2006	TRX350 Rancher	BTL14A240C		
Honda	2003-2005	TRX650 FourTrax Rincon (Std.)	BTL14A240C		
Honda	2003-2004	TRX 680 (Optional Cold Starting)	BTL24A360C	BTL35A480C	
Honda	1998-2004	TRX450 Fourtrax Foreman S, ES	BTL14A240C		
Honda	1997-2003	TRX250 Recon, ES	BTL14A240C		
Honda	1995-2003	TRX400FW Foreman	BTL14A240C		
Honda	1988-2000	TRX300 Fourtrax	BTL14A240C		
Honda	1988-2000	TRX300FW Fourtrax 4x4	BTL14A240C		
Honda	1990-1996	TRX200 Fourtrax	BTL14A240C		
Honda	1989-1990	FL400R Pilot	BTL14A240C		
Honda	1987-1988	TRX125 Fourtrax	BTL09A120C	BTL14A240C	
Honda	1986-1988	TRX200SX Fourtrax	BTL14A240C		
Honda	1986-1987	ATC125M	BTL14A240C		
Honda	1985-1987	ATC250ES Big Red	BTL14A240C		
Honda	1985-1987	ATC250SX	BTL14A240C		
Honda	1985-1987	TRX250 Fourtrax	BTL14A240C		
Honda	1985-1986	TRX125 Fourtrax	BTL14A240C		
Honda	1985	FL350R Odyssey	BTL14A240C		
Honda	1984-1985	ATC125M	BTL14A240C		
Honda	1984-1985	ATC200M	BTL14A240C		
Honda	1984	TRX200 Fourtrax	BTL14A240C		
Honda	1982-1984	ATC200 Big Red	BTL14A240C		
Hyosung	2010-2013	TE450S	BTL09A120C	BTL14A240C	
John Deere	1933-2011	All Models	BTL24A360C	BTL35A480C	

MAKE	YEAR/YEARS	MODEL	PART#	UPGRADE1	UPGRADE2
Kasea	1933-2011	KS, KU Models 90cc	BTL09A120C	BTL14A240C	
Kasea	1933-2011	KS, KU Models 65cc	BTL09A120C	BTL14A240C	
Kasea	1933-2011	KS, KU Models, Adventure Buggy	BTL09A120C	BTL14A240C	
Kasea	1933-2011	Mini Skyhawk	BTL09A120C		
Kasea	1933-2011	Skyhawk 150, Adventure Buggy	BTL09A120C	BTL14A240C	
Kasea	1933-2011	Skyhawk 170	BTL09A120C	BTL14A240C	
Kasea	1933-2011	Skyhawk 250	BTL09A120C	BTL14A240C	
Kasea	1933-2011	Skyhawk 50	BTL09A120C		
Kasea	1933-2011	Skyhawk 90	BTL09A120C		
Kawasaki	2013	KVF300 Brute Force	BTL14A240C		
Kawasaki	2009-2013	KVF360 Prairie	BTL14A240C		
Kawasaki	2008-2013	KFX450R	BTL09A120C		
Kawasaki	2007-2013	KFX50	BTL09A120C		
Kawasaki	2007-2013	KFX90	BTL09A120C		
Kawasaki	2005-2013	KVF750 Brute Force	BTL14A240C		
Kawasaki	2002-2013	KVF650 Brute Force	BTL14A240C		
Kawasaki	2003-2012	KLF250-A Bayou	BTL14A240C		
Kawasaki	2003-2010	KFX700	BTL14A240C		
Kawasaki	2004-2006	KVF650-A, B, D Prairie 700, 4X4	BTL14A240C		
Kawasaki	2004-2006	KVF700-A, B, D Prairie 700, 4x4	BTL14A240C		
Kawasaki	2003-2006	KSF400-A (KFX400)	BTL09A120C	BTL14A240C	
Kawasaki	2003-2005	KLF250-A Bayou (CN)	BTL14A240C		
Kawasaki	2003-2005	KSF80-A (KFX80)	BTL09A120C		
Kawasaki	1992-2005	KLF300-C Bayou 300 4x4 (CN)	BTL24A360C	BTL35A480C	
Kawasaki	1989-2004	KLF300-C Bayou 300 4x4	BTL14A240C		
Kawasaki	1988-2004	KLF300-B Bayou	BTL14A240C		
Kawasaki	2002-2003	4x4 Advantage Classic	BTL14A240C		
Kawasaki	2001-2003	KEF300-A Lakota Sport	BTL14A240C		
Kawasaki	2001-2003	KEF300-B Lakota Sport	BTL14A240C		
Kawasaki	1999-2002	KVF300-A Prairie 300, 4x4	BTL14A240C		
Kawasaki	1999-2002	KVF300-B Prairie 300, 4x4	BTL14A240C		
Kawasaki	1999-2002	KVF300-B Prairie 300, 4x4 (CN)	BTL24A360C	BTL35A480C	
Kawasaki	1999-2002	KVF400-C Prairie 400, 4x4	BTL14A240C		
Kawasaki	1999-2002	KVF400-C Prairie 400, 4x4 (CN)	BTL14A240C		
Kawasaki	1999-2002	KVF400-D Prairie 400, 4x4	BTL14A240C		
Kawasaki	1999-2001	KVF300-A Prairie 300, 4x4 (CN)	BTL24A360C	BTL35A480C	
Kawasaki	1999-2001	KVF400-D Prairie 400, 4x4 (CN)	BTL14A240C		
Kawasaki	1998-2000	KVF400-B Prairie 400 4x4	BTL14A240C		
Kawasaki	1998-2000	KVF400-B Prairie 400 4x4 (CN)	BTL24A360C	BTL35A480C	
Kawasaki	1997-2000	KVF400-A Prairie 400 4x4	BTL14A240C		
Kawasaki	1997-2000	KVF400-A Prairie 400 4x4 (CN)	BTL24A360C	BTL35A480C	
Kawasaki	1995-2000	KEF300-A Lakota	BTL14A240C		
Kawasaki	1993-2000	KLF400-B Bayou 400 4x4	BTL24A360C	BTL35A480C	
Kawasaki	1992-1999	KLF300-B Bayou (CN)	BTL24A360C	BTL35A480C	
Kawasaki	1987-1988	KLF110-B Mojave	BTL14A240C		
Kawasaki	1985-1988	KLF185-A Bayou	BTL14A240C		
Kawasaki	1986-1987	KLF300-A Bayou	BTL24A360C	BTL35A480C	
Kawasaki	1984-1985	KLT250-C Prairie	BTL14A240C		
Kawasaki	1981-1984	KLT200-A, C	BTL14A240C		
Kawasaki	1983	KLT200-B, C	BTL09A120C	BTL14A240C	

MAKE	YEAR/YEARS	MODEL	PART#	UPGRADE1	UPGRADE2
Kawasaki	1983	KLT250-C Prairie	BTL09A120C	BTL14A240C	
Kawasaki	1982-1983	KLT250-A	BTL09A120C	BTL14A240C	
KTM	2010-2013	XC ATV 525cc	BTL09A120C		
KTM	2008-2013	SX ATV 505cc	BTL09A120C		
KTM	2008-2012	SX ATV 450cc	BTL09A120C		
KTM	2008-2012	XC ATV 450cc	BTL09A120C		
KTM	2008-2009	XC ATV 505cc	BTL09A120C		
Kymco	2013	Maxxer 450	BTL24A360C	BTL35A480C	
Kymco	2013	MXU700	BTL24A360C	BTL35A480C	
Kymco	2012-2013	MXU500	BTL24A360C	BTL35A480C	
Kymco	1933-2011	Mongoose 300	BTL14A240C		
Kymco	1933-2011	Mongoose 50	BTL09A120C		
Kymco	1933-2011	Mongoose 90	BTL09A120C		
Kymco	1933-2011	Mongoose, MXU	BTL14A240C		
Kymco	1933-2011	MXU150	BTL09A120C	BTL14A240C	
Kymco	1933-2011	MXU300SD	BTL14A240C		
Polaris	2011-2013	Sportsman, 4x4	BTL24A360C	BTL35A480C	
Polaris	2010-2013	Sportsman 850cc	BTL24A360C	BTL35A480C	
Polaris	2005-2013	Phoenix, Sawtooth	BTL14A240C		
Polaris	2005-2013	Sportsman, 6x6	BTL35A480C		
Polaris	2004-2013	Predator, Outlaw	BTL09A120C		
Polaris	2003-2013	Magnum, Trail	BTL14A240C		
Polaris	2003-2013	Predator, Sportsman, Outlaw	BTL09A120C		
Polaris	1996-2013	Sportsman HO	BTL14A240C		
Polaris	2010-2012	Sportsman EPS, XP	BTL14A240C		
Polaris	2008-2012	Outlaw 525	BTL09A120C	BTL14A240C	
Polaris	1999-2012	All Models (Excl. Predator, Sportsman)	BTL14A240C		
Polaris	1994-2012	All Models 400cc	BTL14A240C		
Polaris	2010	Sportsman Touring, X2	BTL24A360C	BTL35A480C	
Polaris	2010	Sportsman XP	BTL14A240C		
Polaris	2009-2010	Sportsman 700cc	BTL35A480C		
Polaris	2007-2010	Outlaw 450	BTL09A120C	BTL14A240C	
Polaris	2006-2010	Hawkeye, Sportsman 300	BTL14A240C		
Polaris	2006-2010	Sportsman EFI	BTL35A480C		
Polaris	2009	Sportsman Touring, XP, X2	BTL24A360C	BTL35A480C	
Polaris	1933-2009	Sportsman 850cc	BTL35A480C		
Polaris	2002-2008	Sportsman, Military	BTL35A480C		
Polaris	2003-2006	Predator 500	BTL09A120C	BTL14A240C	
Polaris	2004-2005	Sportsman 600c	BTL35A480C		
Polaris	1985-2005	All models 250cc	BTL14A240C		
Polaris	2003	Scrambler	BTL09A120C		
Polaris	1999-2003	Diesel .445 Litre (primary)	BTL35A480C		
Polaris	1999-2003	Diesel .445 Litre (secondary)	BTL14A240C		
Polaris	2001-2002	Scrambler	BTL09A120C		
Polaris	2001-2002	Scrambler, Sportsman	BTL09A120C		
Polaris	1995-2002	All Models 425cc	BTL14A240C		
Polaris	1987-2002	All Models 325cc	BTL14A240C		
Polaris	1998-2001	Sportsman 335cc	BTL14A240C		
Qianjiang	1933-2011	ATV100	BTL09A120C		
Qianjiang	1933-2011	ATV50	BTL09A120C		

MAKE	YEAR/YEARS	MODEL	PART#	UPGRADE1	UPGRADE2
Suzuki	2010-2013	LT-A500 King Quad	No Equivalent		
Suzuki	2009-2013	LT-A400 King Quad	BTL14A240C		
Suzuki	2007-2013	LT-A750 King Quad	No Equivalent		
Suzuki	2003-2013	LT-Z400 QuadSport	BTL09A120C	BTL14A240C	
Suzuki	2002-2013	LT-F250, Ozark	BTL14A240C		
Suzuki	2007-2011	LT-A450X King Quad	BTL14A240C		
Suzuki	2007-2011	LT-R450 QuadRacer	BTL09A120C	BTL14A240C	
Suzuki	2007-2011	LT-Z90 QuadSport	BTL09A120C	BTL14A240C	
Suzuki	2006-2011	LT-Z50 QuadSport	BTL09A120C		
Suzuki	2004-2011	LT-Z250 QuadSport	BTL09A120C	BTL14A240C	
Suzuki	2005-2007	LT-A700X King Quad	No Equivalent		
Suzuki	2004-2007	LT-A500F Vinson 4WD	No Equivalent		
Suzuki	2004-2007	LT-F500F Vinson Manual 4WD	No Equivalent		
Suzuki	2002-2007	LT-A400 Eiger 2WD, F Eiger 4WD	BTL14A240C		
Suzuki	2002-2007	LT-F400 Eiger 2WD, F Eiger 4WD	BTL14A240C		
Suzuki	1987-2006	LT80 QuadSport 80	BTL09A120C		
Suzuki	2004-2005	LT-V700F Twin Peaks	BTL14A240C		
Suzuki	2003	LT-F500F Vinson Manual 4WD	BTL14A240C		
Suzuki	2002-2003	LT-A500F Vinson 4WD	BTL14A240C		
Suzuki	1999-2002	LT-F250F QuadRunner	BTL14A240C		
Suzuki	1999-2002	LT-F300F KingQuad 300cc	BTL14A240C		
Suzuki	1999-2002	LT-F4WDX KingQuad	BTL14A240C		
Suzuki	2000-2001	LT-A500F QuadMaster	BTL14A240C		
Suzuki	1988-2001	LT-F250 QuadRunner	BTL14A240C		
Suzuki	1991-1999	LT-F4WDX KingQuad 280cc	BTL14A240C		
Suzuki	1987-1999	LT-4WD QuadRunner	BTL14A240C		
Suzuki	1988-1993	LT230E QuadRunner	BTL14A240C		
Suzuki	1987-1989	LT300E QuadRunner 300E	BTL14A240C		
Suzuki	1987	LT230E QuadRunner	BTL14A240C		
Yamaha	2011-2013	Grizzly 300 Automatic	BTL14A240C		
Yamaha	2011-2013	YFM12R, Raptor	No Equivalent		
Yamaha	2010-2013	YMF5FG Grizzly	BTL24A360C	BTL35A480C	
Yamaha	2009-2013	YFM90R Raptor	BTL09A120C		
Yamaha	2009-2013	YFZ450R, X	No Equivalent		
Yamaha	2008-2013	YFM25R Raptor, R	No Equivalent		
Yamaha	2007-2013	YFM35FG Grizzly	BTL14A240C		
Yamaha	2007-2013	YFM45FG Grizzly	BTL14A240C		
Yamaha	2007-2013	YFM7FG Grizzly	BTL24A360C	BTL35A480C	
Yamaha	2006-2013	Raptor 700, R, R SE	BTL09A120C	BTL14A240C	
Yamaha	2004-2013	YFM125S, Grizzly	BTL14A240C		
Yamaha	2004-2013	YFM35R Raptor	BTL14A240C		
Yamaha	2004-2013	YFZ450	BTL09A120C	BTL14A240C	
Yamaha	2000-2012	YFM40FB Big Bear	BTL24A360C	BTL35A480C	
Yamaha	2007-2010	YFM25B Big Bear	BTL14A240C		
Yamaha	2006-2010	YFM35FX Wolverine	BTL14A240C		
Yamaha	2003-2010	YFM45FX Wolverine	BTL24A360C	BTL35A480C	
Yamaha	2007-2008	YFM40FG Grizzly	BTL14A240C		
Yamaha	2002-2008	YFM66FA Grizzly	BTL24A360C	BTL35A480C	
Yamaha	1933-2008	YFZ450X	BTL09A120C	BTL14A240C	
Yamaha	2005-2006	YFM25B Bruin	BTL14A240C		

MAKE	YEAR/YEARS	MODEL	PART#	UPGRADE1	UPGRADE2
Yamaha	2004-2006	YFM35B Bruin	BTL14A240C		
Yamaha	2003-2006	YFM40FW Kodiak/Automatic	BTL14A240C		
Yamaha	2001-2005	YFM66R Raptor	BTL14A240C		
Yamaha	1995-2005	YFM35FX Wolverine	BTL14A240C		
Yamaha	1999-2004	YFM25 Bear Tracker	BTL14A240C		
Yamaha	1989-2004	YFA-1 Breeze	BTL14A240C		
Yamaha	2000-2003	YFM40FWN Big Bear	BTL24A360C	BTL35A480C	
Yamaha	1987-2003	YFM35X Warrior	BTL14A240C		
Yamaha	1996-2002	YFM40FW Kodiak/Automatic	BTL24A360C	BTL35A480C	
Yamaha	1998-2001	YFM600FW Grizzly	BTL24A360C	BTL35A480C	
Yamaha	1998-2001	YFV600FW Grizzly	BTL24A360C	BTL35A480C	
Yamaha	1992-2000	YFB250, F Timber Wolf	BTL14A240C		
Yamaha	1987-1999	YFM35F, U Big Bear	BTL14A240C		
Yamaha	1987-1999	YFM35U Big Bear	BTL14A240C		
Yamaha	1993-1995	YFM40FW Kodiak	BTL14A240C		
Yamaha	1987-1995	YFM35ER Moto 4	BTL14A240C		
Yamaha	1989-1991	YFM250 Moto 4	BTL14A240C		
Yamaha	1989	YFU-1/T Pro-Hauler	BTL14A240C		
Yamaha	1985-1989	YFM200, DX Moto 4	BTL14A240C		
Yamaha	1988	YFP35 TerraPro	BTL14A240C		
Yamaha	1983-1986	YTM225DR, DX Tri-Moto	BTL14A240C		
Yamaha	1983-1985	YTM200, E, ER Tri Moto	BTL14A240C		

Scooters

Aprilia	2012-2013	SRV850	BTL14A240C		
Aprilia	2009-2013	Scarabeo 500cc	BTL14A240C		
Aprilia	2009-2013	Scarabeo 200cc	BTL14A240C		
Aprilia	2009-2013	Scarabeo ST	BTL14A240C		
Aprilia	2009-2013	Sport City 250cc	BTL14A240C		
Aprilia	2009-2013	SR50	BTL14A240C		
Aprilia	2008-2013	Sport City 125cc	BTL14A240C		
Aprilia	2008-2013	Sport City 50cc	BTL14A240C		
Aprilia	2012	Atlantic	BTL14A240C		
Aprilia	2009-2010	Mojito	BTL09A120C		
BMW	2011-2013	C600	BTL14A240C		
BMW	2011-2013	C650 GT	BTL14A240C		
E-Ton	2010-2012	Beamer R4-150	BTL09A120C	BTL14A240C	
E-Ton	2010-2012	Matrix 50	BTL09A120C		
E-Ton	2010-2012	Matrix R4-150	BTL09A120C	BTL14A240C	
E-Ton	2010-2012	Sport 150	BTL09A120C	BTL14A240C	
E-Ton	2010-2012	Sport 50	BTL09A120C	BTL14A240C	
E-Ton	2010-2012	Beamer 50, Beamer	BTL09A120C		
Honda	2013	SH125	No Equivalent		
Honda	2013	SH150	No Equivalent		
Honda	2011-2013	PCX150	No Equivalent		
Honda	2010-2013	NHX110 Elite	BTL09A120C		
Honda	2010-2013	PCX	No Equivalent		
Honda	2009-2013	SM250	BTL14A240C		
Honda	2003-2013	NPS50, S Ruckus	No Equivalent		
Honda	2002-2013	CHF50 Metropolitan, II, SP	No Equivalent		
Honda	2002-2013	FSC600 Silver Wing	BTL14A240C		

MAKE	YEAR/YEARS	MODEL	PART#	UPGRADE1	UPGRADE2
Honda	2010-2012	SH125	BTL09A120C		
Honda	2010-2012	SH150	BTL09A120C		
Honda	1933-2011	FES125	BTL09A120C	BTL14A240C	
Honda	1933-2011	FES150	BTL09A120C	BTL14A240C	
Honda	1933-2011	Pantheon 125	BTL09A120C	BTL14A240C	
Honda	2001-2009	NSS250 Reflex	BTL14A240C		
Honda	1933-2009	CH80 Elite	BTL09A120C		
Honda	1933-2009	CN250 Helix	BTL14A240C		
Honda	2005-2008	PS250 Big Ruckus	BTL14A240C		
Honda	1988-2001	SA50 Elite LX, S, SR	BTL09A120C		
Honda	1988-1990	SB50 (All)	BTL09A120C		
Honda	1985-1990	CH250 Elite	BTL14A240C		
Honda	1987	CH150 Elite	BTL09A120C	BTL14A240C	
Honda	1986-1987	CN250 Helix	BTL14A240C		
Honda	1986-1987	NQ50 Spree, 50D SS	BTL09A120C		
Honda	1986-1987	NB50 Aero	BTL09A120C		
Honda	1985-1986	CH150 Elite Deluxe	BTL14A240C		
Honda	1985-1986	TG50 Gyro S (All)	BTL09A120C		
Honda	1985	NH80 Aero	BTL09A120C		
Honda	1984-1985	NQ50 Spree	BTL09A120C		
Honda	1984	CH125 Elite	BTL14A240C		
Honda	1984	NH125 Aero	BTL09A120C		
Honda	1984	NN50MD Gyro	BTL09A120C		
Honda	1983-1984	NB50M Aero	BTL09A120C		
Honda	1983-1984	NH80MD Aero	BTL09A120C		
Honda	1978-1983	PA50I Moped, PA50II	No Equivalent		
Honda	1967-1968	P50 Little Honda	No Equivalent		
Hyosung	2009-2013	NS3-250	BTL09A120C	BTL14A240C	
Hyosung	1933-2011	EZ100	BTL09A120C		
Hyosung	1933-2011	SB50 Super Cab, SD50 Sense, SF50 Prima, Rally, Sense	BTL09A120C		
Kymco	2013	People GT 300cc	BTL14A240C		
Kymco	2013	People GT 200cc	BTL14A240C		
Kymco	2012-2013	Downtown 300	BTL14A240C		
Kymco	2010-2013	Agility 125	BTL09A120C		
Kymco	2009-2013	Agility 50	BTL09A120C	BTL14A240C	
Kymco	2009-2013	People	BTL09A120C		
Kymco	2009-2013	People S 150	BTL09A120C	BTL14A240C	
Kymco	2009-2013	Super 8	BTL09A120C	BTL14A240C	
Kymco	2009-2013	Super 8 150	BTL09A120C	BTL14A240C	
Kymco	2009-2013	Xciting 500i	BTL14A240C		
Kymco	2010-2011	People S 200	BTL09A120C	BTL14A240C	
Kymco	2010-2011	Xciting 250i	BTL14A240C		
Kymco	2009-2011	People 250	BTL14A240C		
Kymco	2009-2010	People S 125	BTL09A120C	BTL14A240C	
Kymco	2009-2010	People S 50	BTL09A120C	BTL14A240C	
Kymco	2009-2010	Super 9	BTL09A120C		
Kymco	2009	Xciting 400i	BTL14A240C		
Piaggio	2009-2013	FLY150	BTL14A240C		
Piaggio	2009-2013	FLY 50	BTL14A240C		
Piaggio	2008-2013	BV500	BTL14A240C		

MAKE	YEAR/YEARS	MODEL	PART#	UPGRADE1	UPGRADE2
Piaggio	2008-2013	MP3 250	BTL14A240C		
Piaggio	2008-2013	MP3 400	BTL14A240C		
Piaggio	2008-2013	MP3 500	BTL14A240C		
Piaggio	2008-2011	BV250	BTL14A240C		
Piaggio	2009	Typhoon	BTL14A240C		
Piaggio	2009	X9	BTL14A240C		
Piaggio - Gilera	2010-2013	Fuoco 500ie	BTL14A240C		
Piaggio - Gilera	2010-2013	SP50	BTL09A120C		
Piaggio - Gilera	2010-2012	Runner 125	BTL14A240C		
Piaggio - Gilera	2010-2012	Runner 200	BTL14A240C		
Piaggio - Gilera	2010-2011	Nexus 300ie	BTL14A240C		
Piaggio - Gilera	2010	Nexus 500ie	BTL14A240C		
Piaggio - Vespa	2012-2013	LX150 4T	BTL14A240C		
Piaggio - Vespa	2010-2013	GTS300, GTV300	BTL14A240C		
Piaggio - Vespa	2010-2013	LX50	BTL14A240C		
Piaggio - Vespa	1933-2010	GTS250	BTL14A240C		
Piaggio - Vespa	1933-2010	GTV250	BTL14A240C		
Piaggio - Vespa	2007	LX150	BTL14A240C		
Suzuki	2003-2013	AN400 Burgman	BTL14A240C		
Suzuki	2003-2013	AN650 Burgman	BTL14A240C		
Suzuki	1980-1991	FA50 Shuttle	No Equivalent		
Suzuki	1979-1983	FS50, FZ50	No Equivalent		
Suzuki	1971	F50, F50R	No Equivalent		
SYM	2010-2013	HD200	BTL09A120C	BTL14A240C	
SYM	2010-2013	MIO 50	BTL09A120C	BTL14A240C	
SYM	2010-2012	Fiddlell50	BTL09A120C	BTL14A240C	
SYM	2010-2012	JetEuro 50	No Equivalent		
SYM	2010-2012	RV250	BTL14A240C		
SYM	2010-2011	Fiddlell125	BTL09A120C	BTL14A240C	
SYM	2010-2011	HD125	BTL09A120C	BTL14A240C	
SYM	2010-2011	SYMply50	BTL09A120C	BTL14A240C	
SYM	1933-2010	RS50	BTL09A120C		
Yamaha	2012-2013	T-MAX	BTL14A240C		
Yamaha	2010-2013	JOG, ZR	BTL09A120C		
Yamaha	2010-2013	Maxam	BTL14A240C		
Yamaha	2010-2013	VOX	BTL09A120C		
Yamaha	2009-2013	XP500 T-Max	BTL14A240C		
Yamaha	2009-2013	Zuma 125	BTL09A120C	BTL14A240C	
Yamaha	2007-2013	XF50W (C3)	BTL09A120C		
Yamaha	2006-2013	XC50 Vino Classic	BTL09A120C		
Yamaha	2004-2013	YP400 Majesty	BTL09A120C	BTL14A240C	
Yamaha	2002-2013	YW50A Zuma	BTL09A120C		
Yamaha	2004-2009	YJ125T Vino 125	BTL09A120C	BTL14A240C	
Yamaha	2006-2007	Morphous	BTL14A240C		
Yamaha	1997-2001	CW50 Zuma II	BTL09A120C		
Yamaha	1992-2001	CY50 Riva Jog	BTL09A120C		
Yamaha	1987-2001	SH50 Riva Razz	BTL09A120C		
Yamaha	1985-2001	XC125 Riva	BTL09A120C		
Yamaha	1988-1991	CG50 Riva	BTL09A120C		
Yamaha	1987-1991	XC200 Riva	BTL14A240C		

MAKE	YEAR/YEARS	MODEL	PART#	UPGRADE1	UPGRADE2
Yamaha	1989-1990	CW50 Zuma	BTL09A120C		
Yamaha	1986-1987	CE50 Riva Jog	BTL09A120C		
Yamaha	1983-1985	XC180 Riva	BTL14A240C		
UTVs					
Arctic Cat	2012-2013	Wildcat 1000, Wildcat 1000 LTD	BTL35A480C		
Arctic Cat	2010-2013	Prowler 1000	BTL35A480C		
Arctic Cat	2010-2013	Prowler 550	BTL35A480C		
Arctic Cat	2010-2013	Prowler 700	BTL35A480C		
Arctic Cat	2009	Prowler 550	BTL24A360C	BTL35A480C	
Arctic Cat	2009	Prowler 700	BTL24A360C	BTL35A480C	
Arctic Cat	2006-2009	Prowler 650	BTL24A360C	BTL35A480C	
BRP (Can-Am)	2011-2013	Commander 1000	BTL24A360C	BTL35A480C	
BRP (Can-Am)	2011-2013	Commander 800	BTL24A360C	BTL35A480C	
Honda	2008-2013	MUV700 Big Red	BTL14A240C		
Kawasaki	2010-2013	KAF620F, Mule 4010 4x4 (CN)	BTL24A360C	BTL35A480C	
Kawasaki	2008-2013	Teryx All Models (CN)	BTL14A240C		
Kawasaki	2005-2013	Mule 600, 610, 610XC	BTL14A240C		
Kawasaki	1933-2011	KAF300, Mule 500, 520, 550	BTL14A240C		
Kawasaki	1933-2011	KAF450, Mule 1000	BTL24A360C	BTL35A480C	
Kawasaki	1933-2011	KAF540, Mule 2010, 2020, 2030	BTL24A360C	BTL35A480C	
Kawasaki	1933-2011	KAF620, Mule 2500, 2510, 2520	BTL24A360C	BTL35A480C	
Kawasaki	1933-2011	KAF620, Mule 3000, 3010, 3020	BTL24A360C	BTL35A480C	
Kawasaki	2003-2007	KAF620, Mule 3010 4x4 Advantage Classic	BTL24A360C	BTL35A480C	
Kymco	2010-2013	UXV500	BTL24A360C	BTL35A480C	
Polaris	2012-2013	RZR 570, EPS	BTL14A240C		
Polaris	2011-2013	Ranger 400	BTL14A240C		
Polaris	2011-2013	Ranger 4x4,	BTL14A240C		
Polaris	2011-2013	Ranger RZR 900c	BTL35A480C		
Polaris	2010-2013	Ranger	BTL35A480C		
Polaris	2010-2013	Ranger RZR 4	BTL35A480C		
Polaris	2009-2013	Ranger RZR 800cc	BTL24A360C	BTL35A480C	
Polaris	2009-2013	Ranger RZR 170cc	BTL14A240C		
Polaris	2006-2010	Ranger 6x6, 4x4	BTL35A480C		
Polaris	2004-2010	Ranger 4x4	BTL35A480C		
Polaris	1998-2004	Ranger 6x6, 4x4	BTL35A480C		
Polaris	2002-2003	Ranger 2x4	BTL35A480C		
Suzuki	2005	QUV620F	BTL24A360C	BTL35A480C	
PWC					
AQA-Jet Co.	1991	Aqua-Jet SX1	BTL24A360C	BTL35A480C	
AQA-Jet Co.	1989-1990	Aqua-Jet SX1	BTL24A360C	BTL35A480C	
Arctic Cat	1997-1999	Tiger Shark 770cc	BTL14A240C		
Arctic Cat	1997-1999	Tiger Shark 640cc	BTL14A240C		
Bombardier Sea-Doo	2010-2013	GTI, GTX, GTR RXP, RXT, WAKE	BTL24A360C	BTL35A480C	
Bombardier Sea-Doo	2007	3D	BTL24A360C	BTL35A480C	
Bombardier Sea-Doo	2003-2007	GTX 4-Tec, RXP	BTL24A360C	BTL35A480C	
Bombardier Sea-Doo	1988-2007	All Other Models	BTL24A360C	BTL35A480C	
Bombardier Sea-Doo	1988-1993	All Models	BTL24A360C	BTL35A480C	
Honda	2003-2013	AquaTrax F-15, F-15X	BTL24A360C	BTL35A480C	
Honda	2002-2009	AquaTrax F/R-12, F/R-12X	BTL24A360C	BTL35A480C	
Kawasaki	2007-2013	JT1500B, C, 250X, Ultra LX, 260(L)X, 300(L)X	BTL24A360C	BTL35A480C	

MAKE	YEAR/YEARS	MODEL	PART#	UPGRADE1	UPGRADE2
Kawasaki	2004-2013	JT1500-A, STX, STX-15F	BTL24A360C	BTL35A480C	
Kawasaki	2003-2013	JS800 SX-R	BTL24A360C	BTL35A480C	
Kawasaki	2002-2007	JT1200-A-B, C, STX-R, STX-12F	BTL24A360C	BTL35A480C	
Kawasaki	1999-2005	JH1200-A, B Ultra 150	BTL24A360C	BTL35A480C	
Kawasaki	1997-2005	JT900 STS, STX	BTL24A360C	BTL35A480C	
Kawasaki	2001-2004	JH1100-B Ultra 130	BTL24A360C	BTL35A480C	
Kawasaki	1997-2003	JT1100 STX	BTL24A360C	BTL35A480C	
Kawasaki	1996-2003	JH1100 ZXi	BTL24A360C	BTL35A480C	
Kawasaki	1995-2002	JS750 SXi, SXi Pro	BTL24A360C	BTL35A480C	
Kawasaki	1995-1999	JH750 E1,F2,G1,G2	BTL24A360C	BTL35A480C	
Kawasaki	1992-1999	JH750 SS, ST, Xi, XiR	BTL24A360C	BTL35A480C	
Kawasaki	1996-1998	JT750 STS, STX	BTL24A360C	BTL35A480C	
Kawasaki	1995-1997	JH750 ST, Zxi	BTL24A360C	BTL35A480C	
Kawasaki	1995-1997	JH900 Zxi	BTL24A360C	BTL35A480C	
Kawasaki	1989-1996	JF650 TS	BTL24A360C	BTL35A480C	
Kawasaki	1993-1995	JH750 B1-b3	BTL24A360C	BTL35A480C	
Kawasaki	1992-1995	JH750 SX,ZX	BTL24A360C	BTL35A480C	
Kawasaki	1992-1995	JS750 SX, ZX	BTL24A360C	BTL35A480C	
Kawasaki	1991-1995	JL650 SC	BTL24A360C	BTL35A480C	
Kawasaki	1987-1995	JS650 SX	BTL24A360C	BTL35A480C	
Kawasaki	1986-1995	JS550 SX	BTL24A360C	BTL35A480C	
Kawasaki	1986-1995	JF650 X2	BTL24A360C	BTL35A480C	
Kawasaki	1987-1992	JS440	BTL24A360C	BTL35A480C	
Kawasaki	1986-1991	JS300 TS SX	BTL24A360C	BTL35A480C	
Kawasaki	1977-1986	JS440	BTL24A360C	BTL35A480C	
Kawasaki	1982-1985	JS550	BTL24A360C	BTL35A480C	
Kawasaki	1976	JS400	BTL24A360C	BTL35A480C	
Polaris	1933-2011	All Models	BTL24A360C	BTL35A480C	
S.O.S. Marine MFG	1933-2011	All Models	BTL24A360C	BTL35A480C	
Ultranautics	1985-1996	Wet Bike	BTL14A240C	BTL18A300C	BTL24A360C
Wet Jet International	1933-2011	All Models	BTL24A360C	BTL35A480C	
Yamaha	2009-2013	FX, FZR, FZS, VXS, VXR	BTL24A360C	BTL35A480C	
Yamaha	2009-2013	Superjet	BTL24A360C	BTL35A480C	
Yamaha	2009-2013	VX	BTL24A360C	BTL35A480C	
Yamaha	1987-2008	All Wave Runner Models	BTL24A360C	BTL35A480C	

Battery Tender Lithium Battery FAQs:

What is the difference between Lithium Ion batteries and Lithium Iron Phosphate batteries?

Lithium-ion batteries are rechargeable batteries that use lithium as one of their active components. Lithium Iron Phosphate Batteries are a type of lithium-ion batteries known for their long life and inherent safety.

How Do I choose the correct Battery Tender® Lithium battery for my application?

Battery Tender® Lithium batteries are available for most Powersport and other small engine start applications. You can find the correct battery for your application from your local Battery Tender® Lithium Battery dealer or online at <http://batterytender.com/products/batteries.html>.

How does the “Lead Acid Equivalent” capacity rating compare to Flooded, AGM, and Gel cell battery ratings?

The capacity of lead acid batteries decreases markedly when discharged at high currents such as when starting a vehicle. This effect is much less for a lithium battery. In fact, when discharged at a current equal to its capacity, a 2 A-hour lithium iron phosphate battery will have as much capacity as a 9 A-hour lead acid battery.

How do I charge and maintain my Battery Tender® Lithium battery?

See next

Can I use a standard Lead Acid charger/maintainer for my Battery Tender® lithium battery?

As long as the battery charger does not have a desulfation mode and the peak voltage does not exceed 14.8V during the charge cycle it can be used to charge a Battery Tender® Lithium Battery. Of course the best way to charge and maintain a Battery Tender® Lithium Battery is to use a Battery Tender® Lithium Battery Charger.

What is the best way to store my battery long term?

A Battery Tender® Lithium Battery has virtually no self-discharge and has a shelf life of 2 years. The best way to store the battery is disconnected from the vehicle in a clean and dry location with the protective covers installed on the positive terminals.

How do I prevent water damage or corrosion to my battery?

A Battery Tender® Lithium Battery has a waterproof construction however the battery should be kept clean to minimize corrosion. A corrosion inhibitor can also be used on the terminal and connections.

How do Lithium batteries Cold Cranking Amps “CCA” rating compare to Lead Acid batteries?

When talking about lithium batteries used for engine starting the term CCA is used when making comparisons of the cranking ability to that of a lead acid battery in the same application. It is important to select a Battery Tender® Lithium Battery that has a CCA rating that is equal or greater than the lead acid battery it is replacing.

What is the warranty on my Battery Tender® Lithium battery?

Warranty Periods

- 1) 0-12 months: Replace free of charge with original receipt or product registration on our website; www.batterytender.com/productregistration.
- 2) 13-24 months: 50% off MSRP with original receipt or registered on website.
- 3) 25-36 months: 35% off MSRP with original receipt or registered on website.

How do I recycle a Lithium battery?

There are no specific federal laws requiring the recycling of Lithium Iron Phosphate batteries however local governments may have different requirements. The Rechargeable Battery Recycling Corporation provides free recycling locations throughout the US and Canada. You can locate their nearest drop off location at www.call2recycle.org/locator/.

How do I ship my Battery Tender® Lithium battery?

Ship the batteries in their original packaging if possible. Check www.batterytender.com before shipping.

What happens if I hook up my battery charger to the wrong terminals?

If you happen to hook up your battery charger cables in reverse (positive cable to negative terminal and negative cable to positive terminal) then you will potentially damage the battery.

What happens if I hook up my battery to the wrong terminals on my vehicle?

If you incorrectly connect your battery to the wrong cables (positive cable to negative terminal and negative cable to positive terminal) then there is a chance for spark and damage to the battery.

