

OWNER'S MANUAL GSV190

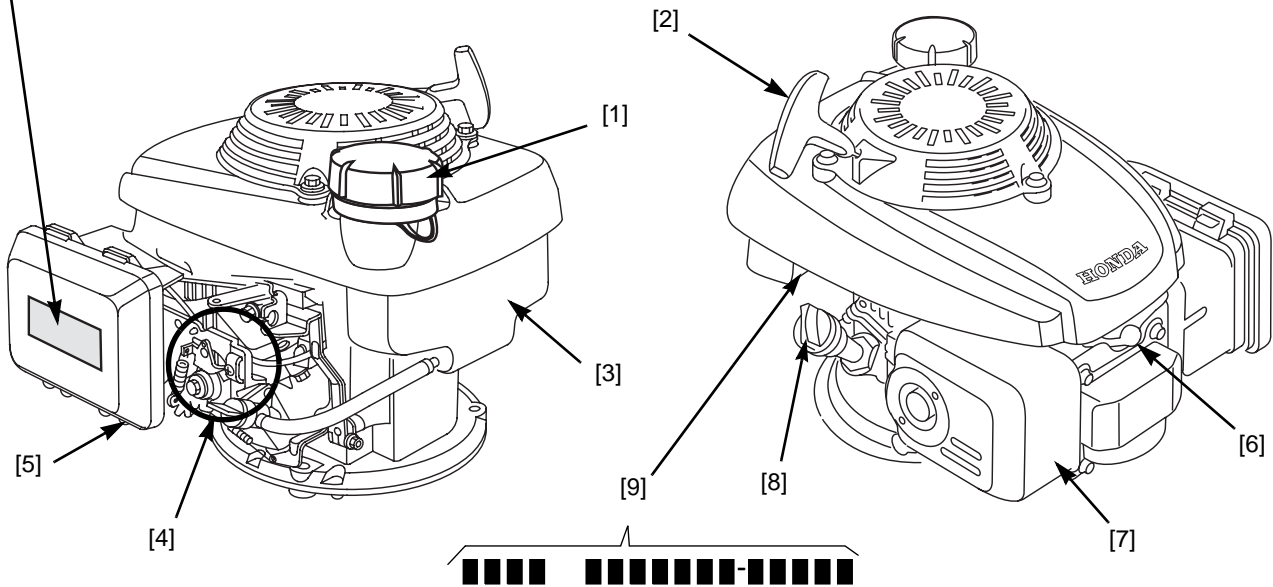

⚠ WARNING
 Gasoline is highly flammable and explosive.
 Turn engine off and let cool before refueling.
 The engine emits toxic carbon monoxide.
 Do not run in an enclosed area.
 Read Owner's Manual before operation.
 Honda Motor Co., Ltd.

⚠ WARNING ⚠
 The engine exhaust from this product
 contains chemicals known to the State
 of California to cause cancer, birth
 defects, or other reproductive harm.



COMPONENT LOCATION

1	Fuel filler cap
2	Starter grip
3	Fuel tank

4	Control location *
5	Air cleaner
6	Spark plug

7	Muffler
8	Oil filler cap/dipstick
9	Engine serial number

* The engine control area differs based on the engine type. Refer to the individual figures on page 2 to determine your engine control type when reading the *Operation* section and other sections in this manual.

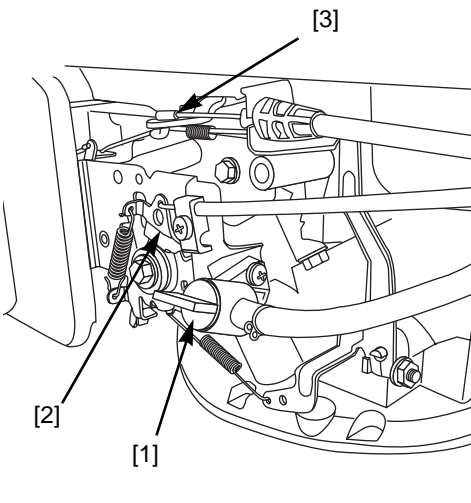
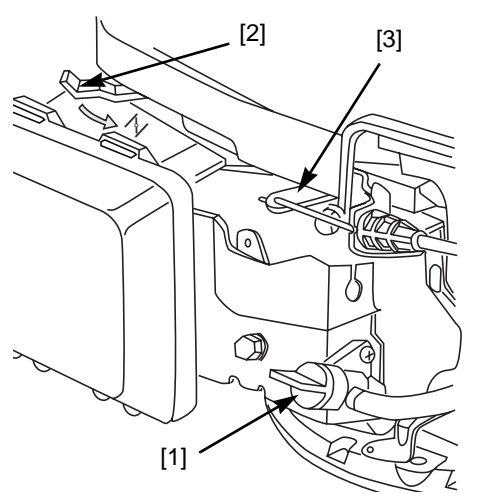
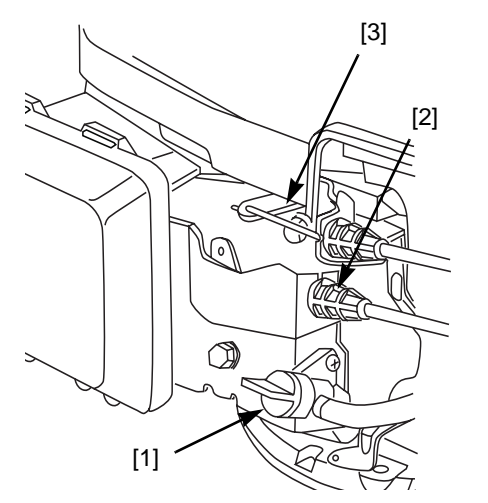
<p>Type 1</p> 	<p>Type 2</p> 	<p>Type 3</p> 
<p>[1] Fuel Valve [2] Remote Choke/Throttle Lever [3] Flywheel Brake Lever</p>	<p>[1] Fuel Valve [2] Automatic Return Choke Lever [3] Flywheel Brake Lever Fixed Throttle</p>	<p>[1] Fuel Valve [2] Remote Choke Cable [3] Flywheel Brake Lever Fixed Throttle</p>

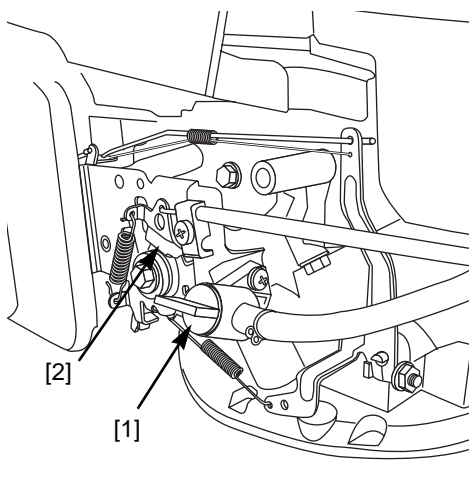
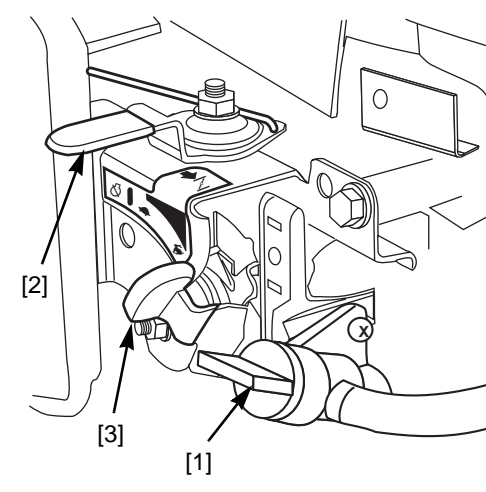
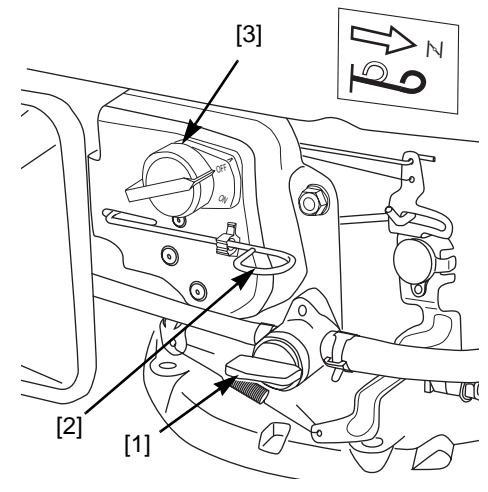
<p>Type 4</p> 	<p>Type 5</p> 	<p>Type 6</p> 
<p>[1] Fuel Valve [2] Remote Choke/Throttle Lever Blade Brake Clutch</p>	<p>[1] Fuel Valve [2] Manual Choke Lever [3] Manual Throttle Lever</p>	<p>[1] Fuel Valve [2] Manual Choke Rod [3] Engine Stop Switch Fixed Throttle</p>

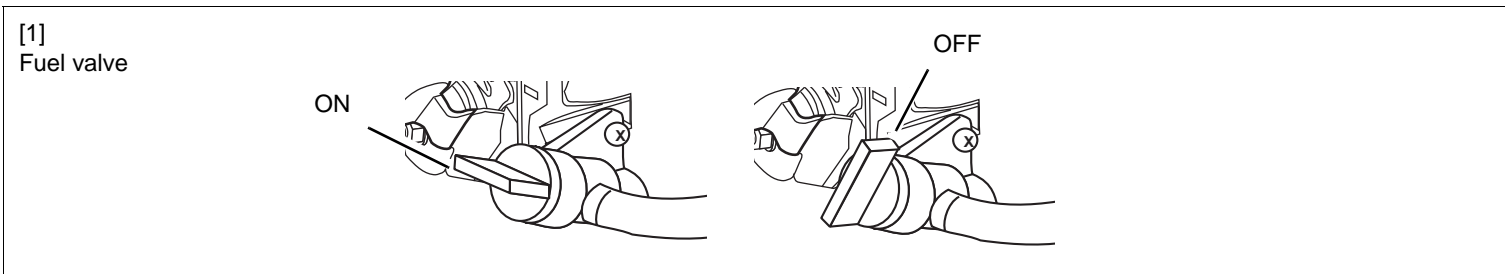

The numbers in brackets [x] are used for reference throughout the manual.

Figure 1

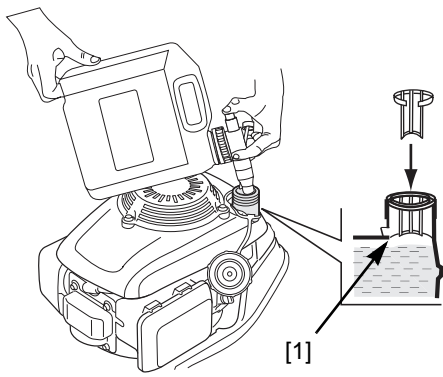

Figure 2

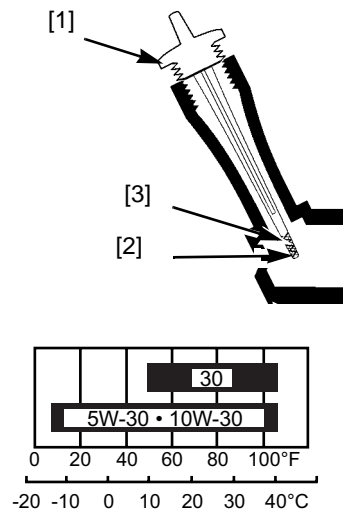

Figure 3

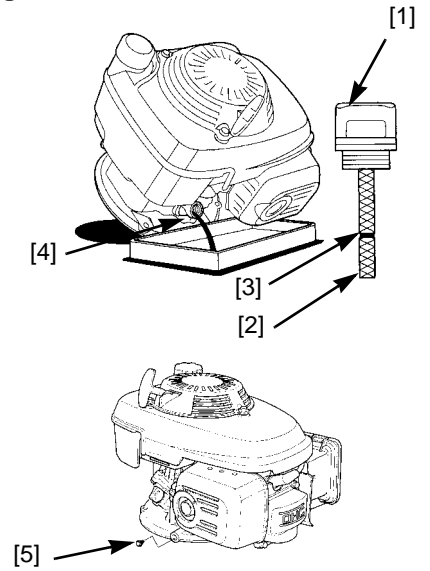

Figure 4

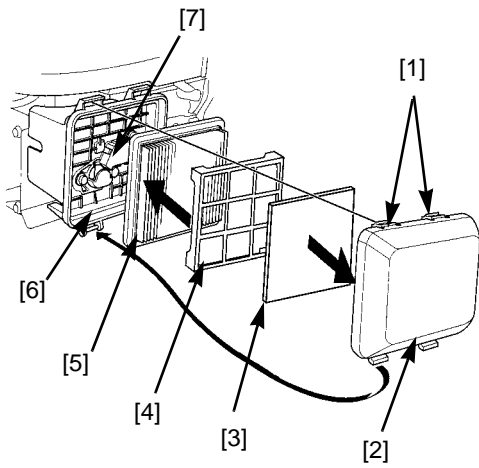

Figure 5

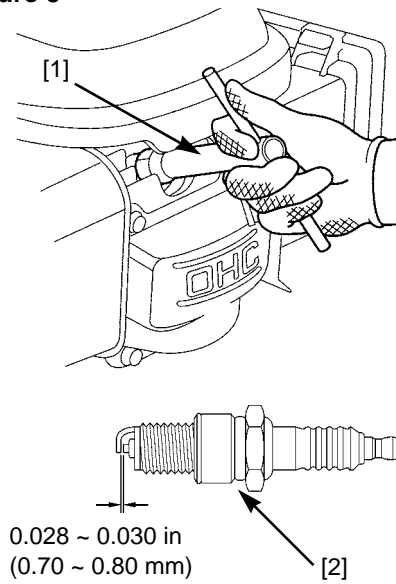

Figure 6

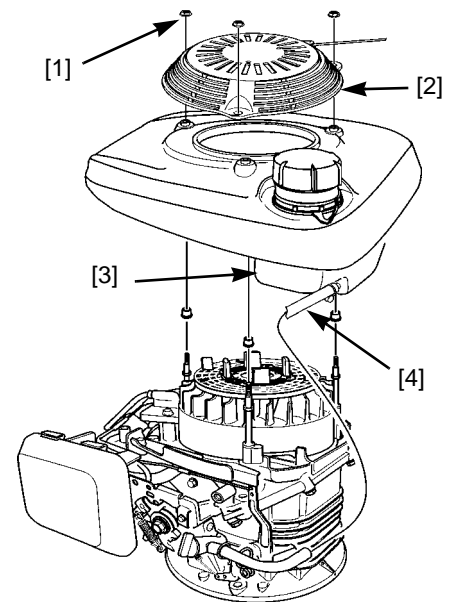

Figure 7

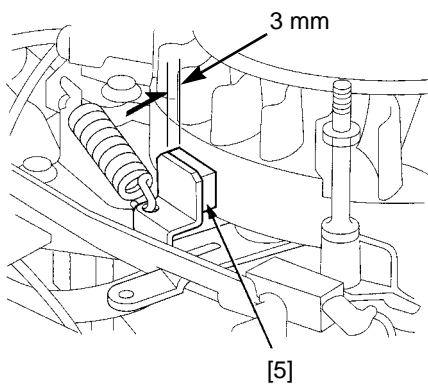
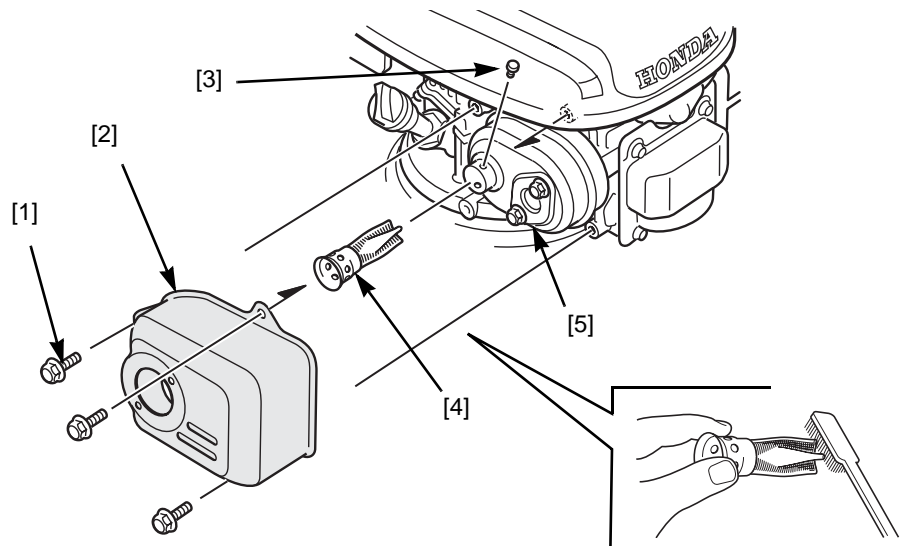

Figure 8



INTRODUCTION

Thank you for purchasing a Honda engine. We want to help you get the best results from your new engine and operate it safely. This manual contains information on how to do that; please read it carefully before operating the engine. If a problem should arise, or if you have any questions about your engine, consult an authorized Honda servicing dealer.

All information in this publication is based on the latest product information available at the time of printing. American Honda Motor Co., Inc. reserves the right to make changes at any time without notice and without incurring any obligation. No part of this publication may be reproduced without written permission.

This manual should be considered a permanent part of the engine and should remain with the engine if resold.

Review the instructions provided with the equipment powered by this engine for any additional information regarding engine startup, shutdown, operation, adjustments, or any special maintenance instructions.

CONTENTS

SAFETY MESSAGES	4
BEFORE OPERATION CHECKS	4
OPERATION	5
SAFE OPERATING PRECAUTIONS	5
STARTING/STOPPING THE ENGINE (ALL TYPES)	5
SERVICING YOUR ENGINE	6
MAINTENANCE SAFETY	6
MAINTENANCE SCHEDULE	6
REFUELING	7
ENGINE OIL	7
AIR CLEANER	8
SPARK PLUG	8
FLYWHEEL BRAKE INSPECTION (if equipped)	8
SPARK ARRESTER (if equipped)	8
STORING YOUR ENGINE	9
TRANSPORTING	9
TAKING CARE OF UNEXPECTED PROBLEMS	10
TECHNICAL INFORMATION	10
CONSUMER INFORMATION	12

SAFETY MESSAGES

Your safety and the safety of others are very important. We have provided important safety messages in this manual and on the engine. Please read these messages carefully.

A safety message alerts you to potential hazards that could hurt you or others. Each safety message is preceded by a safety alert symbol  and one of three words, DANGER, WARNING, or CAUTION.

These signal words mean:

DANGER

You WILL be KILLED or SERIOUSLY HURT if you don't follow instructions.

WARNING

You CAN be KILLED or SERIOUSLY HURT if you don't follow instructions.

CAUTION

You CAN be HURT if you don't follow instructions.

Each message tells you what the hazard is, what can happen, and what you can do to avoid or reduce injury.

DAMAGE PREVENTION MESSAGES

You will also see other important messages that are preceded by the word NOTICE.

This word means:

NOTICE

Your engine or other property can be damaged if you don't follow instructions.

The purpose of these messages is to help prevent damage to your engine, other property, or the environment.

SAFETY INFORMATION

- Understand the operation of all controls and learn how to stop the engine quickly in case of emergency. Make sure the operator receives adequate instruction before operating the equipment.
- Do not allow children to operate the engine. Keep children and pets away from the area of operation.
- Your engine's exhaust contains poisonous carbon monoxide. Do not run the engine without adequate ventilation, and never run the engine indoors.
- The engine and exhaust become very hot during operation. Keep the engine at least 3 feet (1 meter) away from buildings and other equipment during operation. Keep flammable materials away, and do not place anything on the engine while it is running.

SAFETY LABEL LOCATION

The label shown on page 1 contains important safety information. Please read it carefully.

This label is considered a permanent part of your engine. So if the label comes off or becomes hard to read, contact your dealer for a replacement.

BEFORE OPERATION CHECKS

IS YOUR ENGINE READY TO GO?

For your safety, and to maximize the service life of your equipment, it is very important to take a few moments before you operate the engine to check its condition. Be sure to take care of any problem you find, or have your servicing dealer correct it, before you operate the engine.

WARNING

Improperly maintaining this engine, or failing to correct a problem before operation, could cause a malfunction in which you could be seriously injured.

Always perform a pre-operation inspection before each operation, and correct any problem.

Before beginning your preoperation checks, be sure the engine is level and the flywheel brake lever, throttle lever, or engine stop switch is in the STOP or OFF position.

Always check the following items before you start the engine:

1. Fuel level ([page 7](#)).
2. Oil level ([page 7](#)).
3. Air cleaner ([page 8](#)).
4. General inspection: Check for fluid leaks and loose or damaged parts.
5. Check the equipment powered by this engine.

Review the instructions provided with the equipment powered by this engine for any precautions and procedures that should be followed before engine startup.

OPERATION

SAFE OPERATING PRECAUTIONS

Before operating the engine for the first time, please review the *SAFETY MESSAGES* and the *BEFORE OPERATION CHECKS* [page 4](#).

For your safety, do not operate the engine in an enclosed area such as a garage. Your engine's exhaust contains poisonous carbon monoxide gas that can collect rapidly in an enclosed area and cause illness or death.

WARNING

Exhaust contains poisonous carbon monoxide gas that can build up to dangerous levels in closed areas. Breathing carbon monoxide can cause unconsciousness or death.

Never run the engine in a closed or even partially closed area where people may be present.

Review the instructions provided with the equipment powered by this engine for any safety precautions that should be observed with engine startup, shutdown, or operation.

Do not operate the engine on slopes greater than 20°.

FREQUENCY OF USE

If your equipment will be used on an infrequent or intermittent basis (more than 4 weeks between usage), refer to the *Fuel* section of the *STORAGE* chapter ([page 9](#)) for additional information regarding fuel deterioration.

STARTING/STOPPING THE ENGINE (ALL TYPES)

See the figures on [page 2](#) to identify the type of control used on your equipment. Type specific starting and stopping information can be found after the general information shown below.

- **Fuel valve ON:** Turn the fuel valve [1] to the ON position before starting the engine.
- **Manual choke** (if equipped): Place the choke lever/rod [2] in the CHOKE position when starting a cold engine.

Move the choke lever/rod to the OFF position as soon as the engine fully warms up and runs smoothly without use of the choke, or for restarting a warm engine.

- **Starter grip:** Pull the starter grip lightly until resistance is felt, and then pull briskly.

NOTICE

Do not allow the starter grip to snap back against the engine. Return it gently to prevent damage to the starter.

- **Engine speed:** For best engine performance, it is recommended the engine be operated with the throttle in the FAST (or high) position.
- **Fuel valve OFF:** After stopping the engine, turn the fuel valve [1] to the OFF position.

If your equipment will not be used for 3 to 4 weeks, we recommend running the engine's carburetor out of fuel. You can do this by leaving the fuel valve OFF, restarting the engine, and running it out of fuel.

Type 1: Flywheel Brake, Remote Choke/Throttle

STARTING THE ENGINE

1. Move the choke/throttle lever* [2] to the CHOKE position (cold engine).
2. Move the flywheel brake lever* [3] to the RUN position.
3. Pull the starter grip lightly until resistance is felt; then pull briskly.
4. Move the choke/throttle lever* [2] to the FAST position.

STOPPING THE ENGINE

1. Move the choke/throttle lever* [2] to the SLOW position.
2. Release the flywheel brake lever* [3] to stop the engine.

Type 2: Flywheel Brake, Fixed Throttle, Automatic Return Choke

STARTING THE ENGINE

1. Move the automatic return choke [2] to the CHOKE  position (cold engine).
2. Move the flywheel brake lever* [3] to the RUN position.

The choke lever automatically begins moving to the OFF position when the flywheel brake lever is moved to the RUN position.

3. Pull the starter grip lightly until resistance is felt; then pull briskly.
The throttle is preset on this type.

STOPPING THE ENGINE

Release the flywheel brake lever* [3] to stop the engine.

Type 3: Flywheel Brake, Remote Choke, Fixed Throttle

STARTING THE ENGINE

1. Move the choke lever [2] to the CHOKE position (cold engine).
2. Move the flywheel brake lever* [3] to the RUN position.
3. Pull the starter grip lightly until resistance is felt; then pull briskly.
4. Move the choke lever [2] to the OFF position as the engine warms.

The engine speed is preset on this type.

STOPPING THE ENGINE

Release the flywheel brake lever* [3] to stop the engine.

Type 4: Blade Brake Clutch, Remote Choke/Throttle/Stop

STARTING THE ENGINE

1. Move the choke/throttle/stop lever* [2] to the CHOKE position.
2. Make sure the blade control lever* is disengaged.
3. Pull the starter grip lightly until resistance is felt; then pull briskly.
4. Move the choke/throttle/stop lever* [2] to the FAST position as the engine warms, and then engage the blade control lever*.



STOPPING THE ENGINE

1. Disengage the blade control lever*.
2. Move the choke/throttle/stop lever* [2] to the SLOW position, and then the STOP position.



* See the equipment manual for control location.

Type 5: Manual Choke, Manual Throttle

STARTING THE ENGINE

1. Move the choke lever [2] to the CHOKE  position (cold engine).
2. Move the throttle control [3] to the FAST  position.
3. Pull the starter grip lightly until resistance is felt; then pull briskly.
4. Move the choke lever [2] to the OFF position as the engine warms.

STOPPING THE ENGINE

Move the throttle control [3] to the SLOW  position, and then to the STOP  position.

Type 6: Manual Choke, Engine Stop Switch, Fixed Throttle

STARTING THE ENGINE

1. Pull the choke rod [2] to the CHOKE  position (cold engine).
2. Turn the engine stop switch [3] to the ON position.
3. Pull the starter grip lightly until resistance is felt; then pull briskly.
The engine speed is preset on this type.
4. Move the choke rod to the OFF position as the engine warms.
The engine speed is preset on this type.

STOPPING THE ENGINE

Turn the engine stop switch [3] to the OFF position.

SERVICING YOUR ENGINE

THE IMPORTANCE OF MAINTENANCE

Good maintenance is essential for safe, economical, and trouble-free operation. It will also help reduce pollution.

⚠ WARNING

Improper maintenance, or failure to correct a problem before operation, can cause a malfunction in which you can be seriously hurt or killed.

Always follow the inspection and maintenance recommendations and schedules in this Owner's Manual.

To help you properly care for your engine, the following pages include a maintenance schedule, routine inspection procedures, and simple maintenance procedures using basic hand tools. Other service tasks that are more difficult, or require special tools, are best handled by professionals and are normally performed by a Honda technician or other qualified mechanic.

The maintenance schedule applies to normal operating conditions. If you operate your engine under severe conditions, such as sustained high-load or high-temperature operation, or use in unusually wet or dusty conditions, consult your servicing dealer for recommendations applicable to your individual needs and use.

Remember that an authorized Honda servicing dealer knows your engine best and is fully equipped to maintain and repair it.

To ensure the best quality and reliability, use only new Honda Genuine parts or their equivalents for repair and replacement.

Maintenance, replacement, or repair of the emission control devices and systems may be performed by any engine repair establishment or individual, using parts that are "certified" to EPA standards.

MAINTENANCE SAFETY

Some of the most important safety precautions follow. However, we cannot warn you of every conceivable hazard that can arise in performing maintenance. Only you can decide whether or not you should perform a given task.

⚠ WARNING

Failure to properly follow maintenance instructions and precautions can cause you to be seriously hurt or killed.

Always follow the procedures and precautions in this Owner's Manual.

MAINTENANCE SCHEDULE

Perform at every indicated month/year or operating hour interval, whichever comes first. ⁽¹⁾

Regular Service Period	Item	Page
Before each use	Check: Engine oil level Check: Air filter	page 7 page 8
First month or 5 hours	Change: Engine oil	page 7
Every 3 months or 25 hours	Clean: Air filter ⁽²⁾	page 8
Every 6 months or 50 hours	Change: Engine oil ⁽³⁾ Clean: Air filter ⁽²⁾ Check: Flywheel brake pad (if equipped)	page 7 page 8 page 8
Every year or 100 hours	6 month items above plus: Check-adjust: Spark plug Clean: Spark arrester (if equipped) Check: Blade brake clutch ⁽⁵⁾ (if equipped) Check-adjust: Idle speed ⁽⁴⁾ Clean: Fuel tank and filter ⁽⁴⁾ Check-adjust: Valve clearance ⁽⁴⁾	page 8 page 8
Every 2 years or 200 hours	Yearly items above plus: Replace: Air filter Replace: Spark plug	page 8 page 8
Every 2 years	Check: Fuel lines ⁽⁴⁾ (replace if necessary)	

- (1) For commercial use, log hours of operation to determine proper maintenance intervals.
- (2) Service more frequently when used in dusty areas.
- (3) Change engine oil every 25 hours when used under heavy load or in high ambient temperatures.
- (4) These items should be serviced by an authorized Honda servicing dealer, unless you have the proper tools and are mechanically proficient. Refer to the Honda shop manual for service procedures.
- (5) See your equipment manual or Honda engine shop manual.

Failure to follow this maintenance schedule could result in non-warrantable failures.

SAFETY PRECAUTIONS

- Make sure the engine is off before you begin any maintenance or repairs. This will eliminate several potential hazards:

– **Carbon monoxide poisoning from engine exhaust.**

Be sure there is adequate ventilation whenever you operate the engine.

– **Burns from hot parts.**

Let the engine and exhaust system cool before touching.

– **Injury from moving parts.**

Do not run the engine unless instructed to do so.

- Read the instructions before you begin, and make sure you have the tools and skills required.
- To reduce the possibility of fire or explosion, be careful when working around gasoline. Use only a nonflammable solvent, not gasoline, to clean parts. Keep cigarettes, sparks, and flames away from all fuel related parts.

REFUELING

This engine is certified to operate on unleaded gasoline with a pump octane rating of 86 or higher.

We recommend refueling after each use to minimize the air present in the fuel tank.

Refuel in a well-ventilated area with the engine stopped. If the engine has been running, allow it to cool first. Never refuel the engine inside a building where gasoline fumes may reach flames or sparks.

You may use regular unleaded gasoline containing no more than 10% ethanol (E10) or 5% methanol by volume. In addition, methanol must contain cosolvents and corrosion inhibitors. Use of fuels with content of ethanol or methanol greater than shown above may cause starting and/or performance problems. It may also damage metal, rubber, and plastic parts of the fuel system. In addition, ethanol is hygroscopic, which means it attracts and retains water in the fuel system. Engine damage or performance problems that result from using a fuel with percentages of ethanol or methanol greater than shown above are not covered by warranty.

If your equipment will be used on an infrequent or intermittent basis (more than 4 weeks between usage), refer to the *Fuel* section of the STORAGE chapter ([page 9](#)) for additional information regarding fuel deterioration.

Never use stale or contaminated gasoline or oil/gasoline mixture. Avoid getting dirt or water in the fuel tank.

⚠ WARNING

Gasoline is highly flammable and explosive, and you can be burned or seriously injured when refueling.

- Stop engine and keep heat, sparks, and flame away.
- Refuel only outdoors.
- Wipe up spills immediately.

Adding Fuel

See Figure 1, [page 3](#).

1. Remove the fuel tank cap.
2. Add fuel to the bottom of the fuel level gauge [1] in the neck of the fuel tank. Do not overfill. Wipe up spilled fuel before starting the engine.
3. Install the fuel tank cap and tighten it until it clicks.
Move at least 10 feet (3 meters) away from the fueling source and site before starting the engine.

NOTICE

Fuel can damage paint and some types of plastic. Be careful not to spill fuel when filling your fuel tank. Damage caused by spilled fuel is not covered under your Distributor's Limited Warranty.

Fuel Storage Container

Store your gasoline in a clean, plastic, sealed container designed for fuel storage. Close the vent (if equipped) when not in use, and store the container away from direct sunlight. If it takes more than 3 months to use the fuel in the container, we suggest adding a fuel stabilizer to the fuel when you fill the container. If you have some fuel left in the storage container at the end of the season, the Environmental Protection Agency (EPA) suggests adding the gasoline to your vehicle's gas tank (<http://epa.gov/reg50air/mobile/winter.html>).

ENGINE OIL

Oil is a major factor affecting performance and service life. Use 4-stroke automotive detergent oil. Always change the oil in accordance with the maintenance schedule ([page 6](#)).

Recommended Oil

See Figure 2, [page 3](#).

Use 4-stroke motor oil that meets or exceeds the requirements for API service category SJ or later. Always check the API service label on the oil container to be sure it includes the letters SJ or later.

SAE 10W-30 is recommended for general use. Other viscosities shown in the chart may be used when the average temperature in your area is within the indicated range.

Oil Level Check

See Figures 2 and 3 on [page 3](#).

1. Check the oil with the engine stopped and level.
2. Remove the oil filler cap/dipstick [1] and wipe it clean.
3. Insert the oil filler cap/dipstick into the oil filler neck as shown, but do not screw it in, and then remove it to check the oil level.
4. If the oil level is near or below the lower limit mark [2] on the dipstick, fill with the recommended oil to the upper limit mark [3]. Do not overfill.
5. Reinstall the oil filler cap/dipstick [1].

Oil Change

See Figure 3 on [page 3](#).

Drain the engine oil when the engine is warm. Warm oil drains quickly and completely. Place a suitable container next to the engine to catch the used oil.

1. Without oil drain bolt.
Turn the fuel valve to the OFF position to reduce the possibility of fuel leakage.
Remove the oil filler cap/dipstick [1] and drain the oil into the container by tipping the engine toward the oil filler neck [4].
2. With oil drain bolt.
Remove the drain bolt [5] and allow the oil to drain into the container. Reinstall the drain bolt after draining.
Please dispose of used motor oil in a manner that is compatible with the environment. We suggest you take used oil in a sealed container to your local recycling center or service station for reclamation. Do not throw it in the trash, pour it on the ground, or pour it down a drain.
3. With the engine in a level position, fill to the upper limit mark [3] on the dipstick with the recommended oil.

NOTICE

Running the engine with a low oil level can cause engine damage.

4. Reinstall the oil filler cap/dipstick [1] securely.

AIR CLEANER

A properly maintained air filter will help prevent dirt from entering your engine. Dirt entering the carburetor can be drawn into small passages in the carburetor and cause premature engine wear. These small passages can become blocked, causing starting or running problems. You will need to clean the filter more frequently if you operate the engine in very dusty areas.

NOTICE

Operating the engine without an air filter, or with a damaged filter, will allow dirt to enter the engine, causing rapid engine wear. This type of damage is not covered under your Distributor's Limited Warranty.

We recommend the use of a Honda Genuine air filter to ensure it seals and performs as designed. Using a non-Honda air filter can result in dirt bypassing the filter, causing damage to the engine or fuel system.

Inspection

See Figure 4 on [page 3](#).

1. Press the latch tabs [1] on the top of the air cleaner cover [2], and remove the cover.
2. Remove the foam element [3] from the air cleaner cover.
3. Remove the screen grid [4] from the paper element [5].
4. Check both elements to be sure they are clean and in good condition.
5. Reinstall the screen grid over the paper element. Make sure that the screen grid completely surrounds the paper pleats.
6. Reinstall the foam element in the air cleaner cover.
7. Set the paper element and screen grid in the air cleaner body [6], and install the air cleaner cover.

Cleaning

See Figure 4 on [page 3](#).

Wipe dirt from the air cleaner body [6] and cover [2] using a moist rag. Be careful to prevent dirt from entering the air duct [7] that leads to the carburetor.

Paper Element: Tap the filter several times on a hard surface to remove dirt, or blow compressed air [not exceeding 30 psi (207 kPa, 2.1 kg/cm²)] through the filter from the clean side that faces the engine. Never try to brush off dirt. Brushing will force dirt into the fibers.

Foam Element: Wash the element in a solution of household detergent and warm water and rinse thoroughly, or wash in nonflammable or high flash point solvent. Allow the element to dry thoroughly.

Soak the element in clean engine oil and squeeze out the excess oil. The engine will smoke during initial start-up if too much oil is left in the foam, or the oil could saturate the paper element, making the engine inoperable.

SPARK PLUG

See Figure 5 on [page 3](#).

Recommended Spark Plug:

NGK BPR6ES - Pressure washer applications
NGK BPR5ES - All other applications

The recommended spark plug is the correct heat range for normal engine operating temperatures.

NOTICE

Incorrect spark plugs can cause engine damage.

For good performance, the spark plug must be properly gapped and free of deposits.

1. Disconnect the cap from the spark plug, and remove any dirt from the spark plug area.
2. Use the proper size spark plug wrench [1] to remove the spark plug.
3. Inspect the spark plug. Replace it if damaged, badly fouled, if the sealing washer [2] is in poor condition, or if the electrode is worn.
4. Measure the electrode gap with a suitable gauge. The correct gap is 0.028 ~ 0.030 in (0.70 ~ 0.80 mm). If adjustment is needed, correct the gap by carefully bending the side electrode.
5. Install the spark plug carefully, by hand, to avoid cross-threading.
6. After the spark plug is seated, tighten with the proper size spark plug wrench to compress the washer.

When installing a new spark plug, tighten 1/2 turn after the spark plug seats to compress the washer.

When reinstalling the original spark plug, tighten 1/8 ~ 1/4 turn after the spark plug seats to compress the washer.

NOTICE

Properly tighten the spark plug. A loose spark plug can become very hot and can damage the engine. Overtightening the spark plug can damage the threads in the cylinder head.

7. Attach the spark plug cap to the spark plug.

FLYWHEEL BRAKE INSPECTION (if equipped)

See Figures 6 and 7 on [page 3](#).

1. Remove the three flange nuts [1] from the recoil starter [2], and remove the recoil starter from the engine.
2. Remove the fuel tank [3] from the engine without disconnecting the fuel tube [4]. If the fuel tank contains fuel, keep it level as you remove it and set it beside the engine in a level position.
3. Check the brake shoe [5] thickness. If it is less than 3 mm, take the engine to your authorized Honda servicing dealer.
4. Install the fuel tank and recoil starter, and tighten the three nuts securely.

SPARK ARRESTER (if equipped)

See Figure 8 on [page 3](#).

The spark arrester may be standard or an optional part, depending on the engine type. In some areas, it is illegal to operate an engine without a spark arrester. Check local laws and regulations. A spark arrester is available from authorized Honda servicing dealers.

The spark arrester must be serviced every 100 hours to keep it functioning as designed.

If the engine has been running, the muffler will be hot. Allow it to cool before servicing the spark arrester.

Removal

1. Remove the three 6 mm bolts [1] from the muffler protector [2], and remove the muffler protector.
2. Remove the special screw [3] from the spark arrester [4], and remove the spark arrester from the muffler [5].

Cleaning & Inspection

1. Use a brush to remove carbon deposits from the spark arrester screen. Be careful not to damage the screen. Replace the spark arrester if it has breaks or holes.
2. Install the spark arrester in the reverse order of removal.

STORING YOUR ENGINE

STORAGE PREPARATION

Proper storage preparation is essential for keeping your engine trouble-free and looking good. The following steps will help to keep rust and corrosion from impairing your engine's function and appearance, and will make the engine easier to start when you use it again.

CLEANING

If the engine has been running, allow it to cool for at least half an hour before cleaning. Clean all exterior surfaces, touch up any damaged paint, and coat other areas that may rust with a light film of oil.

NOTICE

Using a garden hose or pressure washing equipment can force water into the air cleaner or muffler opening. Water in the air cleaner will soak the air filter, and water that passes through the air filter or muffler can enter the cylinder, causing damage.

FUEL

NOTICE

Depending on the region where you operate your equipment, fuel formulations may deteriorate and oxidize rapidly. Fuel deterioration and oxidation can occur in as little as 30 days and may cause damage to the carburetor and/or fuel system. Please check with your servicing dealer for local storage recommendations.

The length of time that gasoline can be left in your fuel tank and carburetor without causing functional problems will vary with such factors as gasoline blend, your storage temperatures, and whether the fuel tank is partially or completely filled. The air in a partially filled fuel tank promotes fuel deterioration. Very warm storage temperatures accelerate fuel deterioration. Fuel problems may occur within a month of inactivity, or even less if the gasoline was not fresh when you filled the fuel tank.

Gasoline will oxidize and deteriorate in storage. Deteriorated gasoline will cause hard starting, and it leaves gum deposits that can clog the small passages in the fuel system. If the gasoline in your engine deteriorates during storage, you may need to have the carburetor and other fuel system components serviced or replaced.

If you keep a container of gasoline for refueling, be sure that it contains only fresh gasoline. If it takes more than 3 months to use the fuel in your storage container, we suggest adding a fuel stabilizer to the fuel when you fill the container.

Fuel system damage or engine performance problems resulting from neglected storage preparation are not covered under your engine warranty.

Short Term Storage (30 - 90 days)

If your equipment will not be used between 30 and 90 days, we recommend the following to prevent fuel-related problems:

1. Add fuel stabilizer following the manufacturer's instructions. When adding a fuel stabilizer, fill the fuel tank with fresh gasoline. If only partially filled, air in the tank will promote fuel deterioration during storage.

Note:

- All stabilizers have a shelf life and their performance will deteriorate over time.
- Fuel stabilizers will not reconstitute stale fuel.

2. After adding a fuel stabilizer, run the engine outdoors for 10 minutes to be sure that treated gasoline has replaced the untreated gasoline in the carburetor.
3. Turn the fuel valve to the OFF position.
4. Continue to run the engine until it stops from the lack of fuel in the carburetor fuel bowl. Running time should be less than 3 minutes.

Long Term or Seasonal Storage (greater than 90 days)

Start the engine and allow it to run long enough to empty all the gasoline from the entire fuel system (including the fuel tank). Do not allow gasoline to remain in your engine for more than 90 days of inactivity.

ENGINE OIL

1. Change the engine oil (see [page 7](#)).
2. Remove the spark plug (see [page 8](#)).
3. Pour 1 - 2 teaspoons (5 ~ 10 cc) of clean engine oil into the cylinder.
4. Pull the recoil starter several times to distribute the oil.
5. Reinstall the spark plug.

STORAGE PRECAUTIONS

If your engine will be stored with gasoline in the fuel tank, it is important to reduce the hazard of gasoline vapor ignition. Select a well-ventilated storage area away from any appliance that operates with a flame, such as a furnace, water heater, or clothes dryer. Also avoid any area with a spark-producing electric motor, or where power tools are operated.

If possible, avoid storage areas with high humidity, because that promotes rust and corrosion.

If there is gasoline in the fuel tank, leave the fuel valve in the OFF position.

Keep the engine level in storage. Tilting can cause fuel or oil leakage.

With the engine and exhaust system cool, cover the engine to keep out dust. A hot engine and exhaust system can ignite or melt some materials. Do not use sheet plastic as a dust cover. A nonporous cover will trap moisture around the engine, promoting rust and corrosion.

REMOVAL FROM STORAGE

Check your engine as described in the *BEFORE OPERATION CHECKS* section of this manual (see [page 4](#)).

If the fuel was drained during storage preparation, fill the tank with fresh gasoline. If you keep a container of gasoline for refueling, be sure it contains only fresh gasoline. Gasoline oxidizes and deteriorates over time, causing hard starting.

If the cylinder was coated with oil during storage preparation, the engine will smoke briefly at startup. This is normal.

TRANSPORTING

Keep the engine level when transporting to reduce the possibility of fuel leakage. Turn the fuel valve to the OFF position.

Review the instructions provided with the equipment powered by this engine for any procedures that should be followed for transporting.

TAKING CARE OF UNEXPECTED PROBLEMS

Engine will not start

POSSIBLE CAUSE	CORRECTION
Fuel valve is OFF.	Move the fuel valve lever to ON.
Choke is OFF.	Unless the engine is warm, move the choke/throttle lever, choke rod, or choke lever to the CHOKE position.
Ignition switch or engine stop switch is OFF.	Move the flywheel brake lever to RUN position. Throttle lever to FAST position. Engine stop switch to ON.
Out of fuel.	Refuel.
Bad fuel; engine stored without treating gasoline, or refueled with bad gasoline.	Refuel with fresh gasoline.
Spark plug faulty, fouled, or improperly gapped.	Adjust or replace the spark plug (page 8).
Spark plug wet with fuel (flooded engine).	Dry and reinstall the spark plug. Start the engine with the choke/throttle lever in the FAST position. Choke in the OFF position.
Fuel filter clogged, carburetor malfunction, ignition malfunction, valves stuck, etc.	Take the engine to an authorized Honda servicing dealer or refer to the shop manual to replace or repair faulty components as necessary.

Engine lacks power

POSSIBLE CAUSE	CORRECTION
Air filter clogged.	Clean or replace the air filter (page 8).
Bad fuel; engine stored without treating the gasoline, of refueled with bad gasoline.	Refuel with fresh gasoline.
Fuel filter clogged, carburetor malfunction, ignition malfunction, valves stuck, etc.	Take the engine to an authorized Honda servicing dealer or refer to the shop manual to replace or repair faulty components as necessary.

TECHNICAL INFORMATION

Serial Number and Type Location

See Figure on [page 1](#).

Record the engine serial number and type in the space below. You will need this information when ordering parts and when making technical or warranty inquiries.

MODEL	SERIAL NUMBER	TYPE
GSV190	_____ - _____	_____
Date of purchase		

Radio Frequency Interference Label (Canada)

This engine complies with Canadian radio frequency interference regulations, ICES-002.

THIS SPARK IGNITION SYSTEM COMPLIES WITH CANADIAN ICES-002.
CE SYSTÈME D'ALLUMAGE PAR ÉTINCELLE EST CONFORME À LA NORME NMB-002 DU CANADA.

Carburetor Modifications for High Altitude Operation

At high altitude, the standard carburetor air-fuel mixture will be too rich. Performance will decrease, and fuel consumption will increase. A very rich mixture will also foul the spark plug and cause hard starting. Operation at an altitude that differs from that at which this engine was certified, for extended periods of time, may increase emissions.

High altitude performance can be improved by specific modifications to the carburetor. If you always operate your engine at altitudes above 5,000 feet (1,500 meters), have your servicing dealer perform this carburetor modification. This engine, when operated at high altitude with the carburetor modifications for high altitude use, will meet each emission standard throughout its useful life.

Even with carburetor modification, engine horsepower will decrease about 3.5% for each 1,000-foot (300-meter) increase in altitude. The effect of altitude on horsepower will be greater than this if no carburetor modification is made.

When auto throttle type engines are used in high altitude applications, the ability to idle down to 2500 rpm could be diminished. See your servicing dealer for information on adjustments if your auto throttle unit does not idle down with the load released or has trouble returning to full rpm with the load applied.

NOTICE

When the carburetor has been modified for high altitude operation, the air-fuel mixture will be too lean for low altitude use. Operation at altitudes below 5,000 feet (1,500 meters) with a modified carburetor may cause the engine to overheat and result in serious engine damage. For use at low altitudes, have your servicing dealer return the carburetor to original factory specifications.

Emission Control System Information

Source of Emissions

The combustion process produces carbon monoxide, oxides of nitrogen, and hydrocarbons. Control of hydrocarbons and oxides of nitrogen is very important because, under certain conditions, they react to form photochemical smog when subjected to sunlight. Carbon monoxide does not react in the same way, but it is toxic.

Honda utilizes appropriate air/fuel ratios and other emissions control systems to reduce the emissions of carbon monoxide, oxides of nitrogen, and hydrocarbons. Additionally, Honda fuel systems utilize components and control technologies to reduce evaporative emissions.

The U.S., California Clean Air Act, and Environment Canada

EPA, California, and Canadian regulations require all manufacturers to furnish written instructions describing the operation and maintenance of emission control systems.

The following instructions and procedures must be followed in order to keep the emissions from your Honda engine within the emission standards.

Tampering and Altering

NOTICE

Tampering is a violation of Federal and California law.

Tampering with or altering the emission control system may increase emissions beyond the legal limit. Among those acts that constitute tampering are:

- Removal or alteration of any part of the intake, fuel, or exhaust systems.

- Altering or defeating the governor linkage or speed-adjusting mechanism to cause the engine to operate outside its design parameters.

Problems That May Affect Emissions

If you are aware of any of the following symptoms, have your engine inspected and repaired by your servicing dealer.

- Hard starting or stalling after starting.
- Rough idle.
- Misfiring or backfiring under load.
- Afterburning (backfiring).
- Black exhaust smoke or high fuel consumption.

Replacement Parts

The emission control systems on your Honda engine were designed, built, and certified to conform with EPA, California, and Canadian emission regulations. We recommend the use of Honda Genuine parts whenever you have maintenance done. These original-design replacement parts are manufactured to the same standards as the original parts, so you can be confident of their performance. The use of replacement parts that are not of the original design and quality may impair the effectiveness of your emission control system.

A manufacturer of an aftermarket part assumes the responsibility that the part will not adversely affect emission performance. The manufacturer or rebuilder of the part must certify that use of the part will not result in a failure of the engine to comply with emission regulations.

Maintenance

Follow the maintenance schedule on page 6. Remember that this schedule is based on the assumption that your machine will be used for its designed purpose. Sustained high-load or high-temperature operation, or use in unusually wet or dusty conditions, will require more frequent service.

Air Index

An Air Index Information hang tag/label is applied to engines certified to an emission durability time period in accordance with the requirements of the California Air Resources Board.

The bar graph is intended to provide you, our customer, the ability to compare the emissions performance of available engines. The lower the Air Index, the less pollution.

The durability description is intended to provide you with information relating the engine's emission durability period. The descriptive term indicates the useful life period for the engine's emission control system. See your *EMISSION CONTROL SYSTEM WARRANTY* ([page 13](#)) for additional information.

DESCRIPTIVE TERM	APPLICABLE TO EMISSION DURABILITY PERIOD
Moderate	50 hours (0–80 cc inclusive) 125 hours (greater than 80 cc)
Intermediate	125 hours (0–80 cc inclusive) 250 hours (greater than 80 cc)
Extended	300 hours (0–80 cc inclusive) 500 hours (greater than 80 cc) 1000 hours (225 cc and greater)

Specifications GSV190

Length x Width x Height	14.6 x 13.5 x 14.2 in (370 x 342.5 x 360 mm)
Dry weight	28.7 lb (13.0 kg)
Engine type	4-stroke, overhead cam, single cylinder
Displacement [Bore x Stroke]	11.4 cu in (187 cm ³) [2.7 x 2.0 in (69 x 50 mm)]
Fuel tank capacity	0.25 gal (0.93 ℓ)
Fuel consumption	1.4 US qt/hr (1.3 ℓ/hr) @ 3000 rpm
Oil capacity	18.6 oz (0.55 ℓ)
Cooling system	Forced air
Ignition system	Transistorized magneto
PTO shaft rotation	Counterclockwise

Tuneup Specifications

ITEM	SPECIFICATION	MAINTENANCE
Spark plug gap	0.028 ~ 0.031 in (0.7 ~ 0.8 mm)	Refer to page 8 .
Valve clearance (cold)	IN: 0.15 ± 0.04 mm EX: 0.20 ± 0.04 mm	See your authorized Honda dealer
Other specifications	No other adjustments needed.	

Quick Reference Information

Fuel	Type	Unleaded gasoline with a pump octane rating of 86 or higher (page 7).
Engine Oil	Type	SAE 10W-30, API SJ or later, for general use. Refer to page 7 . * Refill amount: 12.0 ~ 13.5 oz. (0.35 ~ 0.41 ℓ)
Carburetor	Idle Speed	1,700 ± 150 rpm
Spark plug	Type	BPR6ES (NGK)
Maintenance	Before each use	Check engine oil level. Refer to page 7 . Check air filter. Refer to page 8 .
	First 5 hours	Change engine oil. Refer to page 7 .
	Subsequent	Refer to the maintenance schedule on page 6 .

* Actual amount will vary due to residual oil remaining in the engine. Always use the dipstick to confirm the actual level (see [page 7](#))

Wiring Diagram

ALL TYPES

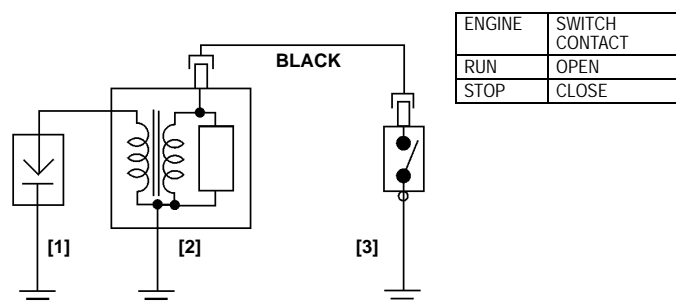

[1]	SPARK PLUG
[2]	IGNITION COIL
[3]	ENGINE STOP SWITCH

CONSUMER INFORMATION

Distributor/Dealer Locator Information

United States, Puerto Rico, and U.S. Virgin Islands:

Visit our website: www.engines.honda.com

Canada:

Call (888) 9HONDA9 [888 946-6329]

or visit our website: www.honda.ca

Honda Publications

These publications will give you additional information for maintaining and repairing your engine.

Shop Manual	This manual covers complete maintenance and overhaul procedures. It is intended to be used by a skilled technician. Available through your Honda dealer or through Helm Inc. at 1 888-292-5395 or visit www.Honda-engines.com and click on Product Manuals.
Parts Catalog	This manual provides complete, illustrated parts lists. Available through your Honda dealer.

Customer Service Information

Servicing dealership personnel are trained professionals. They should be able to answer any question you may have. If you encounter a problem that your dealer does not solve to your satisfaction, please discuss it with the dealership's management. The Service Manager, General Manager, or Owner can help. Almost all problems are solved in this way.

If you are dissatisfied with the decision made by the dealership's management, contact the Honda Regional Engine Distributor for your area. You can find their name, address, and phone number using the dealer/distributor locator on our website at www.hond-engines.com

If you are still dissatisfied after speaking with the Regional Engine Distributor, you may contact the Honda Office as shown below.

<Honda's Office>

When you write or call, please provide this information:

- Equipment manufacturer's name and model number that the engine is mounted on
- Engine model, serial number, and type (see [page 10](#))
- Name of dealer who sold the engine to you
- Name, address, and contact person of the dealer who services your engine
- Date of purchase
- Your name, address and telephone number
- A detailed description of the problem

United States, Puerto Rico, and U.S. Virgin Islands:

American Honda Motor Co., Inc.

Power Equipment Division

Customer Relations Dept.

4900 Marconi Drive

Alpharetta, GA 30005-8847

Or telephone: (770) 497-6400, 8:30 a.m. - 7:00 p.m. ET

Canada:

Honda Canada, Inc.

180 Honda Blvd. Markham, ON L6C 0H9

Telephone: (888) 9HONDA9 Toll free

(888) 946-6329

Facsimile: (877) 939-0909 Toll free

Distributor's Limited Warranty

The applicable warranty is the warranty policy in effect in the country where the warranty service is provided.

PRODUCTS COVERED BY THIS WARRANTY:	LENGTH OF WARRANTY: (FROM DATE OF ORIGINAL PURCHASE)	
	PRIVATE/RESIDENTIAL ⁽¹⁾	COMMERCIAL/RENTAL/INSTITUTIONAL ⁽²⁾
GSV Series Engines	24 months	12 months

(1) Private Residential: Used in maintaining owner's primary and/or secondary residence. Any other use, including but not limited to informal "for hire" use, is considered commercial/rental/institutional.

(2) Honda GCV general purpose engines are not covered by this warranty when installed on concession type vehicles.

To Qualify for this Warranty:

The Honda general purpose engine must be purchased from a Honda general purpose engine dealer or distributor authorized to sell that product in the United States, Puerto Rico, or the U.S. Virgin Islands. This limited warranty applies to first retail purchaser and each subsequent owner during the applicable warranty time period.

What American Honda Will Repair or Replace Under Warranty:

American Honda will repair or replace, at its option, any part that is proven to be defective in material or workmanship under normal use during the applicable warranty time period. Warranty repairs and replacements will be made without charge for parts or labor. Anything replaced under warranty becomes the property of American Honda Motor Company, Inc. All parts replaced under warranty will be considered as part of the original product and any warranty on those parts will expire coincident with the original product warranty.

To Obtain Warranty Service:

You must take your Honda general purpose engine, or the equipment in which it is installed, together with proof of original retail purchase date, at your expense, to a Honda engine dealer or distributor authorized to sell that product in the United States, Puerto Rico, or the U.S. Virgin Islands, during their normal business hours. Many Honda engine dealers and distributors are listed in the yellow pages of the telephone directory under gasoline engines, lawn & garden equipment & supplies, etc.

If you are unable to obtain warranty service, or are dissatisfied with the warranty service you receive, take the following steps: First contact the owner of the dealership or distributor involved. Normally this should resolve the problem. However, if you should require further assistance, write or call the Power Equipment Customer Relations Department of American Honda Motor Co., Inc. listed in the adjacent column.

Exclusions:

This warranty does not extend to parts affected or damaged by the product in which the engine is installed, or by collision, misuse, neglect, parts worn beyond service limits due to normal wear/normal service life, parts affected or damaged by the conversion to or use of fuel other than the fuel(s) which the engine is originally manufactured to use, poor operation related to fuel contamination or fuel quality, parts damaged by fuel contamination, the incorporation of, or use of, unsuitable attachments or parts, the unauthorized alteration of any part or any causes other than defects in material or workmanship of the engine. Use of the Honda general purpose engine for racing or competition will void this warranty. Any engine that is part of a product that has ever been declared a total loss or sold for salvage by a financial institution or insurer.

Disclaimer of Consequential Damage and Limitation of Implied Warranties:

American Honda disclaims any responsibility for loss of time or use of the engine, or the equipment in which the engine is installed, transportation, commercial loss, or any other incidental or consequential damage. Any implied warranties are limited to the duration of this written limited warranty. Some states do not allow limitations on how long an implied warranty lasts and/or do not allow the exclusion or limitation of incidental or consequential damages, so the above exclusions and limitations may not apply to you. This warranty gives you specific legal rights, and you may also have other rights which vary from state to state.

International Warranty

See last pages.

Emission Control System Warranty

Your new Honda Power Equipment engine complies with the U.S. EPA, Environment Canada, and State of California emission regulations (models certified for sale in California only). American Honda Motor Co., Inc. provides the emission warranty coverage for engines in the United States and its territories. Honda Canada Inc. provides the emission warranty for engines in the 13 provinces and territories of Canada. In the remainder of this Emission Control System Warranty, American Honda Motor Company Inc. and Honda Canada Inc. will be referred to as Honda.

YOUR WARRANTY RIGHTS AND OBLIGATIONS:

CALIFORNIA

The California Air Resources Board and Honda are pleased to explain the emission control system warranty on your Honda Power Equipment engine. In California, new spark-ignited small off-road equipment engines must be designed, built, and equipped to meet the State's stringent anti-smog standards.

OTHER STATES, U.S. TERRITORIES, AND CANADA

In other areas of the United States and in Canada, your engine must be designed, built, and equipped to meet the U.S. EPA and Environment Canada emission standards for spark-ignited engines at or below 19 kilowatts. Specific Honda products that do not meet the California emissions regulations can be identified by a "Not for sale in California" decal.

ALL OF THE UNITED STATES AND CANADA

Honda must warrant the emission control system on your power equipment engine for the period of time listed below, provided there has been no abuse, neglect, or improper maintenance of your power equipment engine. Where a warrantable condition exists, Honda will repair your power equipment engine at no cost to you including diagnosis, parts, and labor.

Your emission control system may include such parts as the carburetor or fuel injection system, the ignition system, and catalytic converter. Also included may be hoses, connectors, and other emission-related assemblies. (See adjacent table for additional covered parts).

OWNER'S WARRANTY RESPONSIBILITY:

As the power equipment engine owner, you are responsible for the performance of the required maintenance listed in your owner's manual. Honda recommends that you retain all receipts covering maintenance on your power equipment engine, but Honda cannot deny warranty coverage solely for the lack of receipts or for your failure to ensure the performance of all scheduled maintenance.

As the power equipment engine owner, you should however be aware Honda may deny you warranty coverage if your power equipment engine or a part has failed due to abuse, neglect, improper maintenance, or unapproved modifications.

You are responsible for presenting your power equipment engine to a Honda Power Equipment dealer as soon as a problem exists. The warranty repairs should be completed in a reasonable amount of time, not to exceed 30 days. If you have any questions regarding your emissions warranty rights and responsibilities, you should contact the Honda Office in your region:

American Honda Motor Co., Inc. Power Equipment Customer Relations 4900 Marconi Drive Alpharetta, Georgia 30005-8847 Telephone: (888) 888-3139 Email: powerequipmentemissions @ahm.honda.com	or	Honda Canada Inc. Power Equipment Customer Relations 180 Honda Blvd. Markham, ON L6C 0H9 Telephone: (888) 946-6329
--	----	---

WARRANTY COVERAGE:

Honda power equipment engines sold in the United States and Canada are covered by this warranty for a period of two years from the date of delivery to the original retail purchaser or the length of the Honda Distributor's Limited Warranty, whichever is longer. This warranty is transferable to each subsequent purchaser for the duration of the warranty period.

If any emission-related part on your engine is defective, the part will be repaired or replaced by Honda without charge for diagnosis, parts, or labor. All defective parts replaced under this warranty become the property of Honda. A list of warranted parts is in the adjacent column. Normal maintenance items, such as spark plugs and filters, that are on the warranted parts list are warranted up to their required replacement interval only.

Honda will also replace other engine components damaged by a failure of any warranted part during the warranty period.

Only Honda approved replacement parts may be used in the performance of any warranty repairs and must be provided without charge to the owner. The use of replacement parts not equivalent to the original parts may impair the effectiveness of your engine emission control system. If such a replacement part is used in the repair or maintenance of your engine, and an authorized Honda dealer determines it is defective or causes a failure of a warranted part, your claim for repair of your engine may be denied. If the part in question is not related to the reason your engine requires repair, your claim will not be denied.

TO OBTAIN WARRANTY SERVICE:

You must, at your own expense, take your Honda Power Equipment engine or the product on which it is installed, along with your sales registration card or other proof of original purchase date, to any Honda Power Equipment dealer who is authorized by Honda to sell and service that Honda product during his normal business hours. Claims for repair or adjustment found to be caused solely by defects in material or workmanship will not be denied because the engine was not properly maintained and used.

If you are unable to obtain emission warranty service or are dissatisfied with the warranty service you received, contact the owner of the dealership involved. Normally this should resolve your problem. However, if you require further assistance, contact the Honda office in your region. Refer to adjacent column for contact information.

EXCLUSIONS:

Failures other than those resulting from defects in material or workmanship are not covered by this warranty. This warranty does not extend to emission control systems or parts that are affected or damaged by owner abuse, neglect, improper maintenance, misuse, misfueling, improper storage, collision, the incorporation of, or use of, unsuitable attachments, or the unauthorized alteration of any part.

This warranty does not cover replacement of expendable maintenance items made in connection with required maintenance service after the item's first scheduled replacement as listed in the maintenance section of the product Owner's Manual, such as: spark plugs and filters.

DISCLAIMER OF CONSEQUENTIAL DAMAGE AND LIMITATION OF IMPLIED WARRANTIES:

American Honda Motor Co., Inc. and Honda Canada disclaim any responsibility for incidental or consequential damages such as loss of time or the use of the power equipment, or any commercial loss due to the failure of the equipment; and any implied warranties are limited to the duration of this written warranty. This warranty is applicable only where the California, U.S. EPA or Environment Canada emission control system warranty regulation is in effect.

EMISSION CONTROL SYSTEM WARRANTY PARTS:

SYSTEMS COVERED BY THIS WARRANTY:	PARTS DESCRIPTION:
Fuel Metering	Carburetor assembly, (includes starting enrichment system), Engine temperature sensor, Engine control module, Fuel regulator, Intake manifold
Evaporative	Fuel tank, Fuel cap, Fuel hoses, Vapor hoses, Carbon canister, Canister mounting brackets, Fuel strainer, Fuel cock, Fuel pump, Fuel hose joint, Canister purge hose joint
Exhaust	Catalyst, Exhaust manifold
Air Induction	Air filter housing, Air filter element*
Ignition	Flywheel magneto, Ignition pulse generator, Crankshaft position sensor, Power coil, Ignition coil assembly, Ignition control module, Spark plug cap, Spark plug*
Crankcase Emission Control	Crankcase breather tube, Oil filler cap
Miscellaneous Parts	Tubing, fittings, seals, gaskets, and clamps associated with these listed systems.

Note: This list applies to parts supplied by Honda and does not cover parts supplied by the equipment manufacturer. Please see the original equipment manufacturer's emissions warranty for non-Honda parts.

* Covered up to the first required replacement only. See the *MAINTENANCE SCHEDULE* on [page 6](#).

INFORMASI GARANSI INTERNASIONAL UNTUK MESIN SERBA GUNA Honda

Mesin Serba Guna Honda yang dipasang pada produk buatan manufaktur lain (OEM) ini dijamin oleh garansi Honda, berdasarkan persyaratan berikut:

- Syarat garansi ini berlaku bagi mesin serba guna yang ditetapkan Honda untuk masing-masing negara.
- Garansi ini berlaku untuk kerusakan mesin yang disebabkan oleh masalah produksi atau spesifikasi.
- Garansi ini tidak berlaku bagi negara-negara yang tidak memiliki distributor Honda.

Cara mereparasi produk yang memiliki garansi:

Bawalah produk Anda ke dealer yang berkaitan dengan produk-produk mesin Honda atau dealer tempat Anda membeli produk tersebut, dengan membawa nota pembelian yang Anda terima saat Anda membeli produk tersebut sebagai bukti bahwa produk Anda masih memiliki garansi. Apabila dealer tersebut memiliki bahwa mesin Anda perlu diperbaiki, maka perbaikan akan diberikan.

KETERANGAN JAMINAN ANTARABANGSA UNTUK Honda GENERAL PURPOSE ENGINES

The Honda General Purpose Engine yang dinstal dalam produk OEM dilindungi oleh jaminan Honda, dalam penerimaan berikut:

- Syarat jaminan menurut kepada general-purpose engine yang dikeluarkan oleh Honda di setiap negara.
- Syarat jaminan berlaku untuk kerusakan enjin yang disebabkan sebarang pembuatan atau spesifikasi tertentu.
- Jaminan ini tidak berlaku untuk negara dimana yang tidak ada pendergar honda.

Bagaimana hendak membetulkan/membaliki produk anda dibawah jaminan:

Hantarkan produk OEM anda kepada pendergar yang mengedar produk Honda Power atau pendergar yang anda beli produk anda daripadanya, dengan rest dimasa pembelian sebagai bukti yang produk anda masih dibawah jaminan kerosakan. Sekiranya pendergar mengutarakan supaya produk anda perlu dibaliki, jaminan pembalikan akan di jalankan.

INTERNATIONAL WARRANTY INFORMATION FOR Honda GENERAL PURPOSE ENGINES

The Honda General Purpose Engine installed on this OEM product is covered by a Honda warranty, on the following assumptions.

- The warranty conditions conform to those for the general purpose engine established by Honda for each country.
- The warranty conditions apply to engine failures caused by any manufacturing or specification problem.
- The warranty does not apply to countries where there is no Honda distributor.

How to have your product repaired under warranty:

Bring your OEM product to the dealer who deals with Honda power products or the dealer who you purchased your product from, with the receipt you received at the time of purchase as evidence that your product is still under warranty. If the dealer judges that the engine needs to be repaired, warranty repair will be performed.

معلومات عن الضمانة الدولية لمحرك هوندا للأغراض العامة

محركات هوندا للأغراض العامة التي تم تركيبها على المنتجات التي توصلها بواسطة شركات أخرى تكون مشمولة بضمانة هوندا، وتخضع الضمانة الأساسية لما يلي:

- حالات الضمانة المطابقة لهذه المحركات للأغراض العامة تم وضعها من قبل هوندا لكل بلد.
- يتم تطبيق شروط الضمانة على أعمال المحرك التي سببها من أي خلل بالتصنيع أو مشاكل بالمواد.
- لا يتم تطبيق الضمانة على البلدان التي لا يوجد فيها موزع هوندا.

كيفية إصلاح جهازك تحت هذه الضمانة

خذ جهازك إلى الوكيل الذي يتعامل بمنتجات الطائفة من هوندا أو الوكيل الذي اشترت منه مع مستند الشراء الذي استلمته عند وقت الشراء، كي يرهان على أن جهازك لازال مشمول بالضمانة. إذا قرر الوكيل أن المحرك، في حاجة إلى إصلاح، يتم تنفيذ التصليح حسب الضمانة.

本田通用引擎國際保固通知

該OEM產品 中安裝的本田通用引擎包含有下列前提下的保固承諾。

- 保固條件應符合本田針對各國制定的通用引擎的保固條件。
- 保固條件適用於因任何製造或規格問題所造成的引擎故障。
- 該保固不適用於無本田經銷商的國家。

如何使您的產品得到保固修理:

將您的OEM產品送到辦理本田動力產品的經銷商或您購買該產品的經銷商，出示購買時所得到的發票，以證明您的產品仍在保固期內。若經銷商斷定該引擎需要修理時，就會得到保固修理。

혼다 범용엔진에 대한 보증수리 안내

OEM

- 가
- 가
- 가

보증수리방법

OEM

- 가
- 가

Honda 汎用エンジン 保証のご案内

このOEM 製品 (相手先ブランド製品) に搭載されたHonda汎用エンジンにはHondaの保証が適用されます。基本的な考え方は、以下の通りです。

- 保証条件は、その国においてHondaが定めている汎用エンジンの保証条件に従います。
- エンジン修理の原因が製造上、仕様上のトラブルによるものである場合に保証が適用されます。
- その国にHondaディストリビューターが無い場合は、保証は受けられません。

保証修理の受け方

保証期間内であることの確認のため、製品購入時の領収書と共に、Honda汎用製品を扱っているディーラー又はOEM 製品をお買い上げになったディーラーに製品をお持ちください。Hondaエンジンを修理する必要があるとそのディーラーが判断した場合は、保証修理が行われます。

© Honda Motor Co., Ltd. Revised: March 2009 (PWL53374-B) Printed in U.S.A.

INFORMATIONS SUR LA GARANTIE INTERNATIONALE DES MOTEURS A USAGE GENERAL Honda

Le moteur à usage général Honda installé sur ce matériel OEM est couvert par une garantie Honda dans les conditions suivantes:

- Les conditions de garantie sont conformes à celles pour le moteur à usage général établies par Honda pour chaque pays.
- Les conditions de garantie s'appliquent aux pannes de moteur causées par un problème de fabrication ou de spécification.
- La garantie ne s'applique pas aux pays où il n'existe pas de distributeur Honda.

Comment faire réparer votre matériel sous la garantie:

Amenez votre matériel OEM chez le revendeur s'occupant de matériels de puissance Honda ou chez le revendeur où vous avez acheté votre matériel, avec le reçu d'achat en main comme preuve que votre matériel est encore sous garantie. Si le revendeur estime que le moteur a besoin d'être réparé, la réparation aura lieu sous garantie.

INFORMATIONEN ZUR INTERNATIONALEN GARANTIE FÜR Honda-INDUSTRIEMOTOREN

Der in diesem Erstausrüster-Produkt installierte Honda-Industriemotor ist unter den nachfolgend aufgeführten Voraussetzungen von der Honda-Garantie abgedeckt.

- Die für Industrienmotoren geltenden Garantiebestimmungen wurden von Honda für jedes Land festgelegt.
- Die Garantie gilt für Motordefekte, die durch einen Fabrikationsfehler oder inkorrekte Spezifikationen verursacht wurden.
- Die Garantie gilt nicht in Ländern, in denen kein Honda-Großhändler vorhanden ist.

Vorgehensweise bei einem Garantiefall:

Bringen Sie Ihr Erstausrüster-Produkt zu einem Honda-Händler für motorgetriebene Geräte oder zu Ihrem Verkaufshändler. Zum Beweis, daß das Produkt noch durch die Garantie abgedeckt ist, muß zu dieser Zeit der Verkaufsbeleg vorgelegt werden. Nachdem der Händler bestätigt, daß eine Reparatur des Motors erforderlich ist, werden die nötigen Garantiearbeiten ausgeführt.

INTERNATIONALE GARANTIE INFORMATIE VOOR Honda ALGEMEEN-GEBRUIK MOTOREN

De Honda algemeen-gebruik motor die op dit EOM product is gemonteerd, is gedekt door een Honda garantie, waarbij het volgende in acht moet worden genomen:

- De garantievoorwaarden voldoen aan die voor de algemeen-gebruik motoren opgesteld door Honda voor ieder land.
- De garantievoorwaarden zijn van toepassing op motordefecten die veroorzaakt zijn door fabricage- of specificatiefouten.
- De garantie geldt niet in landen waar geen Honda distributeur is.

Repareren van het product onder de garantie:

Breng uw OEM product naar een dealer die Honda elektrische producten verkoopt of naar de dealer waarvan u het product heeft gekocht, tezamen met het bewijs van aankoop zodat de dealer kan zien dat het product nog onder de garantie is. Indien de dealer van oordeel is dat de motor gerepareerd moet worden, zal deze onder de garantie worden gerepareerd.

INFORMAZIONI SULLA GARANZIA INTERNAZIONALE PER I MOTORI Honda PER USO GENERICO

La garanzia Honda è applicabile sui motori Honda per uso generico che equipaggiano macchine prodotte da altri costruttori ed è assoggettata alle seguenti regole:

- Le condizioni di garanzia sono conformi a quelle per i motori per uso generico stabilite da Honda per ogni nazione.
- Le condizioni di garanzia si applicano da problemi del motore causati da qualsiasi problema di produzione o specifico.
- La garanzia non si applica alle nazioni nelle quali non è presente nessun rivenditore Honda.

Procedura per ottenere interventi in garanzia:

Portare il prodotto al proprio costruttore dal rivenditore che tratta prodotti motorizzati Honda o dal rivenditore dal quale si è acquistato il prodotto, con la ricevuta fornita nel momento dell'acquisto, come prova che il prodotto è ancora in garanzia. Se il rivenditore ritiene che il motore necessita di riparazioni, verranno eseguite le riparazioni in garanzia.

INFORMACIÓN SOBRE LA GARANTÍA INTERNACIONAL DE LOS MOTORES Honda DE USO GENERAL

El motor Honda de uso general instalado en este producto de fabricante de equipo original (OEM) está cubierto por una garantía de Honda, bajo las condiciones siguientes:

- Las condiciones de garantía conforman las de los motores de uso general establecidas por Honda para cada país.
- Las condiciones de garantía se aplican a las averías de motores causadas por un problema de fabricación o de especificaciones.
- La garantía no se aplica en los países en los que no haya ningún distribuidor de Honda.

Cómo hacer para que le reparen su producto en garantía:

Lleve su producto OEM al concesionario que comercializa productos motorizados Honda o al concesionario donde usted compró su producto, llevando el recibo que le entregaron en el momento de la compra como prueba de que su producto está todavía en garantía. Si el concesionario cree que hay que reparar el motor, se le realizará la reparación aplicando la garantía.

INFORMAÇÃO SOBRE A GARANTIA INTERNACIONAL PARA MOTORES Honda PARA USO GERAL

O motor Honda para uso geral neste produto OEM é coberto pela garantia Honda de acordo com os seguintes princípios.

- As condições da garantia conformam com as condições de garantia para motores de uso geral estabelecidas pela Honda no país em questão.
- As condições de garantia são para falhas do motor causadas por qualquer problema de fabricação ou especificação.
- A garantia não é válida em países onde não há um distribuidor Honda.

Para obter o serviço sob a garantia:

Lleve o seu produto OEM para um revendedor que venda produtos montados com motor Honda ou ao revendedor onde comprou o produto, com o recibo que recebeu no ato da compra como uma evidência que o produto ainda está na garantia. Se o revendedor julgar que o motor precisa ser reparado, o reparo será realizado através da garantia.

本田通用发动机国际保修通知

该OEM产品中安装的本田通用发动机包含有下列前提下的本田保修承诺。

- 保修条件应符合本田针对各国制定的通用发动机的保修条件。
- 保修条件适用于因任何制造或规格问题所造成的发动机故障。
- 该保修不适用于无本田经销商的国家。

如何使您的产品得到保修修理:

将您的OEM产品送到办理本田动力产品的经销商或您购买该产品的经销商，出示购买时所得到的发票，以证明您的产品仍在保修期内。若经销商断定该发动机需要修理时，就会得到保修修理。

ข้อมูลเกี่ยวกับการรับประกันสินค้าของชาวประมง

สำหรับเครื่องยนต์บนเรือประมงของฮอนด้า

เครื่องยนต์บนเรือประมงของฮอนด้าที่ได้รับการติดตั้งในผลิตภัณฑ์ OEM นี้ ได้ถูกครอบคลุมในการรับประกันของฮอนด้า ตามเงื่อนไขดังต่อไปนี้

- เงื่อนไขในการรับประกันนี้ใช้สำหรับเรือยนต์บนเรือประมงที่ผลิตโดยฮอนด้าในแต่ละประเทศ
- เงื่อนไขในการรับประกันนี้จะรับประกันเกี่ยวกับความเสียหายของเครื่องยนต์ที่มีสาเหตุมาจากการผลิตหรือจากภัยพิบัติที่มีการระบุเฉพาะ
- การรับประกันนี้จะไม่ครอบคลุมในประเทศที่ไม่มีตัวแทนจำหน่ายของฮอนด้า

การเข้ารับบริการของฮอนด้าโดยเรือประมง:

นำผลิตภัณฑ์ OEM ของท่านไปยังผู้จำหน่ายผลิตภัณฑ์ที่มีการจัดตั้งสาขาของฮอนด้าหรือตัวแทนจำหน่ายฮอนด้าที่ท่านได้ทำการซื้อผลิตภัณฑ์นี้ในเรือประมงหรือสถานที่ที่ท่านได้รับใบเสนอซื้อเพื่อแจ้งปัญหาหรือขอความช่วยเหลือเกี่ยวกับฮอนด้าเครื่องยนต์ของฮอนด้าที่ท่านซื้อ

การรับประกันนี้จะไม่ครอบคลุมในประเทศที่ไม่มีตัวแทนจำหน่ายของฮอนด้า

การเข้ารับบริการของฮอนด้าโดยเรือประมง

นำผลิตภัณฑ์ OEM ของท่านไปยังผู้จำหน่ายผลิตภัณฑ์ที่มีการจัดตั้งสาขาของฮอนด้าหรือตัวแทนจำหน่ายฮอนด้าที่ท่านได้ทำการซื้อผลิตภัณฑ์นี้ในเรือประมงหรือสถานที่ที่ท่านได้รับใบเสนอซื้อเพื่อแจ้งปัญหาหรือขอความช่วยเหลือเกี่ยวกับฮอนด้าเครื่องยนต์ของฮอนด้าที่ท่านซื้อ

INTERNATIONAL GARANTIINFORMATORER FOR Honda UNIVERSALS MOTORER

Honda universalmotoren, der er monteret på dette OEM-produkt, dækkes af en Honda-garanti under følgende forudsætninger.

- Garantibetingelserne er i overensstemmelse med dem, Honda har fastlagt for universalmotorer i hvert enkelt land.
- Garantibetingelserne gælder for motorfejl forårsaget af fremstillings- eller specifikationsproblemer.
- Garantien gælder ikke for lande, hvor der ikke findes en Honda-distributør.

Hvordan produktet kan repareres under garanti:

Indlevér OEM-produktet til forhandleren, der tager sig af eldrevne Honda-produkter eller forhandleren, som du købte produktet af, med kvitteringen som bevis på, at produktet stadig er under garanti. Hvis forhandleren vurderer, at motoren skal repareres, vil der blive udført en garantireparation.

ΠΛΗΡΟΦΟΡΙΕΣ ΠΟΥ ΑΦΟΡΟΥΝ ΤΗ ΔΙΕΘΝΗ ΕΓΓΥΗΣΗ ΓΙΑ ΤΟΥΣ ΚΙΝΗΤΗΣ ΓΕΝΙΚΗΣ ΧΡΗΣΗΣ ΤΗΣ Honda

Ο Κινητήρας Γενικής Χρήσης της Honda που έχει τοποθετηθεί σε αυτό το προϊόν OEM (Original Equipment Manufacturer – Κατασκευαστής Πρωτότυπου Εξοπλισμού) καλύπτεται από εγγύηση της Honda, με τις παρακάτω προϋποθέσεις.

- Οι προϋποθέσεις της εγγύησης πληρούν εκείνες που ισχύουν τον κινητήρα γενικής χρήσης που διατίθεται από τη Honda σε κάθε χώρα.
- Οι προϋποθέσεις της εγγύησης ισχύουν για αστοχίες των κινητήρων που θα προκληθούν από οποιοδήποτε πρόβλημα προδιαγραφών κατασκευής.
- Η εγγύηση δεν ισχύει για τις χώρες όπου δεν υπάρχει δανομέας της Honda.

Πώς θα επικοινωνήσετε το προϊόν σας που καλύπτεται από εγγύηση:

Φέρτε το προϊόν OEM στην αντιπροσωπία που διαθέτει τέτοιου είδους προϊόντα της Honda ή στο κατάστημα από όπου αγοράσατε το προϊόν, μαζί με την απόδειξη αγοράς, η οποία αποδεικνύει ότι το προϊόν σας παραμένει εντός εγγύησης. Εάν η αντιπροσωπία κρίνει ότι ο κινητήρας χρειάζεται επισκευή, η επισκευή θα καλυφθεί από την εγγύηση.

Hondan YLEISMOOTTOREITA KOSKEVIA KANSAINVÄLISIÄ TAKUUTUETTOJA

Tähän OEM-tuotteeseen asennettu Hondan yleismoottori kuuluu Hondan takuu piiriin seuraavin ehdoin:

- Takuehdot ovat yhdenmukaiset yleismoottorin takuehtojen kanssa, jotka Honda on laatinut kullekin maalle.
- Takuehdot koskevat valmistusvirheitä tai laatuviasta johtuvia moottorivikoja.
- Takuu ei ole voimassa maissa, joissa ei ole Honda-jälleenmyyjää.

Kuinka tuote korjautetaan takuu puitteissa

Tuo OEM-tuote jälleenmyyjälle, joka hoitaa Honda-moottorilla varustettuja tuotteita tai jolta ostit tuotteesi, sekä ostokuitti todisteeksi tuotteen takuun voimassaolosta. Jos jälleenmyyjän mukaan moottori täytyy korjata, se tehdään takuukorjauksena.

INTERNASJONAL GARANTIINFORMASJON FOR Honda GENERAL PURPOSE ENGINES

Honda General Purpose Engine som er installert på dette OEM-produktet, er dekket av en Honda-garanti, på følgende antakelser.

- Garantibetingelsene oppfyller de for motorene til generelt formål som er fastlagt av Honda for hvert land.
- Garantibetingelsene gjelder for motorsvikt forårsaket av ettvett produktjons- eller spesifikasjonsproblem.
- Garantien gjelder ikke i land der det ikke finnes noen Honda-distributør.

Hvordan du får produktet reparert på garanti:

Bring ditt OEM-produkt til forhandleren som forhandler Honda kraftprodukter eller forhandleren der du kjøpte produktet, med kvitteringen du mottok ved kjøpetidspunktet som bevis på at produktet ditt fortsatt er dekket av garantien. Hvis forhandleren mener at motoren har behov for å repareres, vil det uføres garantireparasjon.

INFORMATION OM INTERNATIONELL GARANTI FÖR Honda-MOTORER FÖR ALLMÄNNA ÄNDAMÅL

Honda-motorn för allmänna ändamål som är monterad på denna OEM-produkt, täcks av en Honda-garanti under följande förutsättningar.

- Garantin kräver att man rättar sig efter de villkor för Honda för allmänna ändamål som fastslagits av Honda för respektive land.
- Garantivillkoren gäller för motorfel som orsakats av tillverknings- eller specifikationsproblem.
- Garantin gäller inte i länder där Honda inte har någon distributör.

Så här får du din produkt reparerad enligt garantin:

Ta din OEM-produkt till återförsäljaren som handlar med Honda-drivna produkter, eller återförsäljaren som du köpte din produkt av, tillsammans med kvittot som du fick vid köpet som ett bevis på att garantin fortfarande gäller för din produkt. Om återförsäljaren gör bedömningen att motorn måste repareras, kommer garantireparation att utföras.

INFORMAȚII DE GARANȚIE INTERNAȚIIONALĂ PENTRU MOTOARELE DE UZ GENERAL Honda

Motorul de uz general Honda montat pe acest produs OEM se află sub acoperirea garanției Honda, în baza următoarelor premise.

- Condițiile de garanție sunt conforme cu acelea pentru motorul de uz general stabilite de Honda pentru fiecare țară.
- Condițiile de garanție se aplică defecțiunilor motorului cauzate de orice problemă de producție sau concepție.
- Garanția nu se aplică în țările în care nu există distribuitor Honda.

Cum să procedați pentru repararea produsului aflat în garanție:

Aduceți produsul OEM la dealerul care se ocupă cu produsele electrice Honda sau la cel de la care ați achiziționat produsul, împreună cu chitanța pe care ați primit-o în momentul achiziției, ca dovadă că produsul se află încă în garanție. Dacă dealerul apreciază că motorul trebuie reparat, vor fi efectuate reparații sub efectul garanției.

INFORMACE O MEZINÁRODNÍ ZÁRUČE PRO UNIVERZÁLNÍ MOTORY Honda

Univerzální motor Honda namontovaný na tento výrobek typu OEM je krytý zárukou společnosti Honda za následujících předpokládu.

- Záruční podmínky jsou v souladu se záručními podmínkami univerzálního motoru stanovenými společností Honda pro každou zemi.
- Záruční podmínky se vztahují na závady motoru způsobené výrobní nebo technickou vadou.
- Záruka se nevztahuje na země, ve kterých není žádný distributor Honda.

Jak si nechat opravit výrobek krytý zárukou:

Odvezte váš OEM výrobek k prodejci, který prodává motorové stroje Honda nebo k prodejci, od kterého jste výrobek koupili, s sebou vezměte doklad, který jste obdrželi při koupi, na důkaz toho, že výrobek je stále kryt zárukou. Pokud prodejce usoudí, že motor je nutné opravit, bude provedena záruční oprava.

INFORMACIE NA TEMAT MIĘDZYKRAJOWEJ GWARANCJI NA UNIWERSALNE SILNIKI Honda

Uniersalny silnik Honda zamontowany w tym produkcie OEM jest objęty gwarancją firmy Honda zgodnie z poniższymi założeniami.

- Warunki gwarancji odpowiadają warunkom dla uniwersalnego silnika Honda ustalonemu przez firmę Honda dla poszczególnych krajów.
- Warunki gwarancji odnoszą się do usterek silnika spowodowanych nieodpowiednim wykonaniem lub danymi technicznymi.
- Gwarancja nie obowiązuje w krajach, w których nie ma dystrybutorów firmy Honda.

Oddanie produktu do naprawy gwarancyjnej:

Należy dostarczyć produkt OEM do dealera zajmującego się rozprawdaniem podzespołów napędowych Honda, u którego został zakupiony produkt oraz okazać pokwitowanie otrzymane w chwili zakupu na poświadczenie faktu, że jest on objęty gwarancją. Jeśli dealer uzna, że silnik wymaga naprawy, zostanie przeprowadzona naprawa gwarancyjna.

Honda ÁLTALÁNOS CÉLŰ MOTOROKRA VONATKOZÓ NEMZETKÖZI JÓTÁLLÁSI INFORMÁCIÓK

Az erre az OEM termékre szerelt Honda általános célú motorra a Honda jótállása vonatkozik, a következő feltételek teljesülése mellett:

- A jótállási feltételek összhangban vannak a Honda által az adott országban alkalmazott általános célú motorokra vonatkozó jótállási feltételekkel.
- A jótállási feltételek olyan motorhibára vonatkoznak, melyet gyártási hiba vagy a műszaki specifikációkból adódó hiba okozott.
- A jótállás nem érvényes azokban az országokban, ahol nincs hivatalos Honda viszonteladó.

Hogyan járjon el, ha jótállás alatt lévő termék garanciális javításra szorul:

Vigye az OEM terméket egy olyan viszonteladóhoz, aki Honda gépek forgalmazásával foglalkozik vagy, ahhoz a viszonteladóhoz, aktól a terméket megvásárolta, és vigye magával a számlát, melyet a termék vásárlásakor kapott. Ezzel a számlával igazolja, hogy a termék a jótállási időn belül van. Ha a viszonteladó úgy itéli meg, hogy a motort javítani kell, a javítás a garanciális feltételek szerint történik.

INFORMACIJA PAR Honda UNIVERSÁLNO DZINĚJU STARPTAUTISKO GARANTIJU

Uz Honda univerzálo dzinēju, kas uzstādīts uz šī OEM produkta, attiecas Honda garantija, ņemot vērā sekojošos pieņēmumus.

- Garantijas nosacījumi atbilst nosacījumiem, kurus Honda ir noteikusi universālajiem dzinējiem katrā valstī.
- Garantijas noteikumi attiecas uz dzinēja atteici, kas radusies saņošanas vai specifikāciju pabeikšanas rezultātā.
- Šī garantija neattiecas uz valstīm, kurās nav Honda izplatītāju.

Kā salabot jūsu produktu garantijas ietvaros:

Nogādājiet savu OEM produktu piegādātājam, kas atbild par Honda āaudas ierīcēm, vai piegādātājam, no kura jūs iegādājāties produktu, ar precīzes iegādes čeku kā pierādījumu tam, ka uz jūsu produktu attiecas garantijas apakļošana. Ja izplatītājs nolem, ka dzinējs ir jāsalabo, tiks veikts garantijas remonts.

INFORMACIJE O MEZINÁRODNEJ ZÁRUČE NA UNIVERZÁLNÉ MOTORY Honda

Na univerzálny motor Honda použitý v tomto OEM výrobku sa vzťahuje záruka poskytovaná spoločnosťou Honda, ak sú splnené nasledujúce podmienky:

- Záručné podmienky sú v súlade so záručními podmienkami pre univerzálny motor stanovenými spoločnosťou Honda pre konkrétnu krajinu.
- Záručné podmienky sa vzťahujú na poruchy motora spôsobené výrobnou chybou alebo nedosahovaním stanovených technických parametrov.
- Záruka sa nevzťahuje na krajiny, v ktorých nepôsobí žiaden predajca značky Honda.

Ako postupovať pri uplatňovaní záručnej opravy:

Prinesť OEM výrobok predajcovi motorových výrobkov Honda alebo predajcovi, ktorý vám výrobok predal. Ako dôkaz, že na výrobok sa stále vzťahuje záruka, si so sebou prineste doklad o kúpe, ktorý vám bol vystavený v čase kúpy. Ak predajca rozhodne, že motor vyžaduje opravu, vykoná sa záručná oprava.

MEDNARODNE GARANCIJSKE INFORMACIJE ZA VEČNAMENSKE MOTORJE Honda

Večnamenski motor Honda, ki je vgrajen v tem izdelku OEM, krije garancija Honda pod naslednjimi pogoji:

- Garancijski pogoji so skladni s pogoji za večnamenske motorje, ki jih je družba Honda določila za vsako državo.
- Garancijski pogoji veljajo za odpovedi motorja, ki so nastale zaradi napak v proizvodnji ali načrtovanju.
- Garancija ne velja za države, kjer ni distributerja Honda.

Kako uveljavite garancijsko popravilo izdelka:

Svoj izdelek OEM prinesite prodajalcu motornih izdelkov Honda ali prodajalcu, pri katerem ste kupili svoj izdelek, in predložite potrdilo o nakupu kot dokazilo, da je izdelek še v garancijskem roku. Če prodajalec presodi, da je treba motor popraviti, bo opravljeno garancijsko popravilo.

ИНФОРМАЦИЯ ЗА МЕЖДУНАРОДНАТА ГАРАНЦИЯ НА ДВИГАТЕЛИТЕ Honda С ОБЩО ПРЕДНАЗНАЧЕНИЕ

Двигателът Honda с общо предназначение, монтиран на този продукт, собствено производство, се покрива от гаранцията на Honda при следните условия.

- Гаранционните условия съответстват на установените от Honda за двигателите с общо предназначение за всяка държава.
- Гаранцията покрива всички повреди на двигателя, причинени от проблеми при производство или проблеми с техническите характеристики.
- Гаранцията е невалидна в държави, в които няма официален дистрибутор на Honda.

Как да ремонтирате Вашия продукт в рамките на гаранцията:

Занесете Вашия продукт на дилъра, който търгува с двигателите Honda или на дилъра, от който сте закупили продукта, заедно с квитанцията, получена при покупката, като доказателство, че той все още е в гаранция. Ако дилърът прецени, че двигателът се нуждае от ремонт, на същия ще бъде извършен гаранционен ремонт.

INFORMATSIOON Honda ÜLDOTSTARBELISTE MOOTORITE RAHVUSVANHELISE GARANTII KOHTA

Sellele lõpptootja tootele (OEM-tootele) on paigaldatud Honda üldotstarbeline mootor, millele kehtib Honda garantii järgmistel eeldustel.

- Garantitingimused vastavad üldotstarbelistele mootoritele nendele garantidele, mis on kehtestatud Honda poolt iga riigi jaoks.
- Garantitingimusi rakendatakse mootoririkele, mis on põhjustatud mistahes töötlemisveast või nõuetele mittevastavusest.
- Garantii ei kehti riikides, kus Honda maaletooja puudub.

Garantii ajal tehke oma riikis tootega järgmist.

Tooge oma OEM-toode Honda mootorite edasimüüjale või edasimüüjale, kellel te oma toote ostsite, lisades ostmise ajal saadud kvitlringi, millega on tõestatud, et tootele kehtib garantii. Garantiremont tehakse siis, kui edasimüüja otsustab, et remont on vajalik.

TARPTAUTINĖS GARANTIJOS INFORMACIJA „HONDA“ BENDROSIOS PASKIRTIES VARIKLIAMS

„Honda“ bendrosios paskirties varikliams, įdiegtiems šiamė OEM gaminyje, taikoma „Honda“ garantija, jei yra laikomasi šių sąlygų:

- Bendrosios paskirties variklių garantijos sąlygos atitinka tas, kurias „Honda“ nustatė kiekvienai šaliai.
- Garantinės sąlygos taikomos variklio gedimams, kurie kilo dėl gamybių ar specifikacijos klaidų.
- Garantija netaikoma tose šalyse, kuriose nėra „Honda“ platintojų.

Gaminio garantinis taisyimas:

Pristatytike savo OEM gaminį „Honda“ gaminijų platintojui arba pardavėjui, iš kurio pirkote savo gaminį, kartu su pirkimo metu įteiktu čekiu, kuris yra pirkimo ir garantijos taikymo įrodymas. Pardavėju nusprendus, kad variklį reikia remontuoti, atliekamas garantinis remontas.

ИНФОРМАЦИЯ ПО МЕЖДУНАРОДНЫМ ГАРАНТИЙНЫМ ОБЯЗАТЕЛЬСТВАМ, ОТНОСЯЩИМСЯ К ДВИГАТЕЛЯМ Honda ОБЩЕГО НАЗНАЧЕНИЯ

Двигатель Honda общего назначения, установленный на данном OEM-изделии, подпадает под гарантийные обязательства компании Honda при соблюдении указанных ниже условий.

- Условия гарантийного обслуживания соответствуют условиям, принятым для двигателей Honda общего назначения в каждой из стран.
- Условия гарантийного обслуживания распространяются на все неисправности двигателей, созданные с ненадлежащим качеством изготовления или комплектацией.
- Гарантийные обязательства не распространяются на страны, где нет дистрибуторов компании Honda.

КАК ОСУЩЕСТВИТЬ ГАРАНТИЙНЫЙ РЕМОНТ ВАШЕГО ИЗДЕЛИЯ

Доставте ваше OEM-изделие в сервисный центр компании Honda, который авторизован для работы с двигателями общего назначения, или к дилеру, который продал вам это изделие, взяв с собой документы, подтверждающие, что срок его гарантийного обслуживания не истек. Если представитель дилера установит, что изделие нуждается в ремонте, он будет осуществлен в рамках гарантийного обслуживания.

HONDA
The Power of Dreams