

Installation and Operating Instructions



GOL PUMPS TECHNOLOGY INC

Immersible Pumps

en	SBK,CBK	Installation and Operating Instructions
cn	SBK,CBK	使用說明書



EC DECLARATION OF CONFORMITY

according to the following EC Directives

- Machinery Directive : 2006/42/EC/ as amended by 98/37/EC
- Low Voltage Directive : 2006/95/EC
- Electromagnetic Compatibility Directive : 2004/108/EC



The undersigned, R. T. W. S. IEN, representing STAIRS INDUSTRIAL CO., LTD. / No.27, Lane 267, Huacheng Rd., Sinhuang City, Taipei County 242, Taiwan, R.O.C., manufacturer, declares that the machine described hereafter:

Immersible pump

Model :

SBK,CBK series

Provided that it is used and maintained in accordance with the general accepted codes of good practice and the recommendations of the instructions manual, meet the essential safety and health requirements of the Machinery Directive, Low Voltage Directive and Electromagnetic Compatibility Directive.
For the most specific risks of this machine, safety and compliance with the essential requirements of the Directive has been based on elements of:

- EN ISO 12100-1 : 2003 / Safety of Machinery - Basic concepts, general principles for design
Part 1: Basic terminology, methodology.
- EN ISO 12100-2 : 2003 / Safety of Machinery - Basic concepts, general principles for design
Part 2 : Technical principles and specifications.
- EN 809:1998/AC:2001 Pumps and pump units for liquids – Common safety requirements
- EN ISO 13857 : 2008 / Safety of machinery - Safety distance to prevent danger zones being reached by the upper and lower limbs
- EN 414 : 2000 / Safety of machinery - Rules for the drafting and Presentation of safety standards
- EN 953 : 1997 / Safety of machinery - Guards - General requirements for the design and construction of fixed and movable guards
- EN ISO 14121-1:2007 / Safety of machinery - Risk assessment – Part1: Principles
- EN 60204-1 : 2006 / Safety of machinery - Electrical equipment of machines -
Part 1 : General requirements. Industrial electrical device.
- EN 61000-6-2 : 2001 / Electromagnetic compatibility (EMC)
Part 6-2 : Generic standards – Immunity for industrial environments
- EN 61000-6-4 : 2001 / Electromagnetic compatibility (EMC)
Part 6-4 : Generic standards – Emission standard for industrial environments

Date: 02.06.2011

Signature: R. T. W. S. IEN

Qualification: FACTORY MANAGER



⚠ Please read this installation and operating instructions carefully before beginning installation and operation.

1. Application

- 1.1 The SBK,CBK Series is multi-stage centrifugal pump designed for transferring liquid used in machine tools.
- 1.2 The pump can not be used to transfer explosive liquids, such as gasoline,diesel oil and other simillar liquids. It is only suitable for water diluted, low viscosity, uncorrosive cooling or lubricant liquids.

2. Type Keys

The pump models are coded based on the number of pump stages. Standard stages consist of both diffusers pump stages. Standard stages consist of both diffusers and impellers, and null stages,for special installation stages,for special installation considerations, contain diffuser chamber only. The pump model is shown on the pump nameplate.

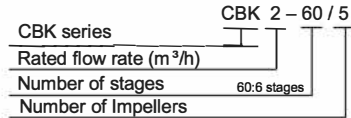
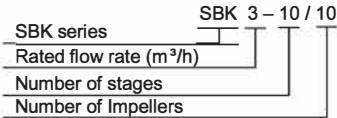

3. Technical Data

Liquid Temperature: -10°C ~ +90°C
Ambient Temperature: +50°C
Enclosure Class: IP55
Insulation class: F

4. Installation

⚠ The pump has hot surface on the motor. It must be installed so that persons cannot accidentally come into contact the hot surface.

4.1 Suction conditons

To avoid dry running and damage the pump during operation,the minimum pump submerged depth is 40mm as shown in Fig 1. In addition, the bottom of the pump strainer must be at least 25 mm above the bottom of the tank.

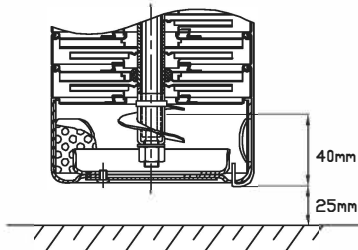

Fig 1



5. Electrical Connection



5.1 The electrical connection should be carried out in accordance with local regulations. Never make any connections unless the electricity supply has been switched off.



5.2 The electrical hazard warning mark is placed outside the connection box.

- 5.3 Electrical data (voltage and frequency) are shown on the pump nameplate. Verify if these shown on the pump nameplate. Verify if these data match your electricity supply. A circuit breaker should be installed and the grounding be properly connected for your safety.
- 5.4 Make electrical connection in accordance with connecting diagram located inside the connection box. The motor current must be within the rated amps range indicated on nameplate. Three phase motor requires a magnetic starter for safety.
- 5.5 Three phase motor must check rotating direction. The rotating direction indicated on the fan cover, is clockwise viewing from fan cover end. Interchanging any two leads with power off can reverse the pump rotation.

6. Start-up

Before starting the pump, make sure the following:

- 6.1 Start the pump and check the direction of rotation.
- 6.2 All piping joints are completely tightened. Leakage in piping may cause the pump hydraulic loss.
- 6.3 The pump is filled with liquid.
- 6.4 The suction filter is not blocked by any foreign objects.

7. Maintenance



It is dangerous to operate the pump against a closed discharge outlet because it will cause extremely high liquid flow temperature and damage the pump in a few minutes.

- 7.1 Lubrication
The mechanical seal and shaft sleeves are lubricated by the pumped liquid.
- 7.2 Filter
Always keep suction filter clean and make sure it is not blocked by impurities
- 7.3 Periodic checks.
The following checks should be carried out periodically to ensure the normal operation periodically to ensure the normal operation.
- 7.3.1 The liquid level and operating pressure.
- 7.3.2 There are no leaks on piping and joints.
- 7.3.3 Check the tripping of the motor starter.
- 7.3.4 Check that all controls are functional.
- 7.4 The pump must not be used to transfer explosive liquids. In systems with hot liquids (over 60 °C), extra caution should be exercised to prevent from personal injury.
- 7.5 The pump should not be used to transfer toxic or contaminated liquids.
Please carefully follow all instructions in the manual as STAIRS may refuse to accept the contaminated pump for servicing.



8. Trouble Shooting

Make sure electricity supply has been switched off before trouble shooting

Fault	Cause	Remedy
1. Motor does not run when started.	a. Supply failure.	Connect the electricity supply.
	b. Fuses are blown.	Replace fuses.
	c. Motor starter overload has tripped out..	Reactivate the motor protection.
	d. Thermal protection has tripped out.	Reactivate the thermal protection.
	e. Main contacts in motor starter are not making contact or the coil is faulty.	Replace contacts or magnetic coil.
	f. Control circuit is defective.	Repair the control circuit.
	g. Motor is defective.	Replace the motor.
2. Motor starter overload trips out immediately when supply is switched on.	a. One fuse/automatic circuit breaker is blown.	Cut in the fuse.
	b. Contacts in motor starter overload are faulty.	Replace motor starter contacts.
	c. Cable connection is loose or faulty.	Fasten or replace the cable connection.
	d. Motor winding is defective.	Replace the motor.
	e. Pump mechanically blocked.	Remove the mechanical blocking of the pump.
	f. Overload setting is too low.	Set the motor starter correctly.
3. Motor starter overload trips out occasionally.	a. Overload setting is too low.	Set the motor starter correctly.
	b. Low voltage at peak times.	Check the electricity supply.
4. Motor starter has not tripped out but the pump does not run.	a. Supply failure.	Connect the electricity supply.
	b. Fuses are blown.	Replace fuses.
	c. Thermal protection has tripped out.	Reactivate the thermal protection.
	d. Main contacts in motor starter are not making contact or the coil is faulty.	Replace contacts or magnetic coil.
5. Pump runs but gives no liquid or pump capacity is not constant.	a. Pump strainer partly blocked by impurities.	Clean the strainer.
	b. Liquid level in tank too low.	Increase the liquid level.
	c. Pump draws in air.	Check the suction conditions.
6. Leakage in shaft seal.	a. Shaft seal is defective.	Replace the shaft seal.
7. Noise.	a. Cavitation occurs in the pump.	Check the suction conditions.
	b. Pump does not rotate freely (frictional resistance) because of incorrect pump shaft position.	Adjust the pump shaft.

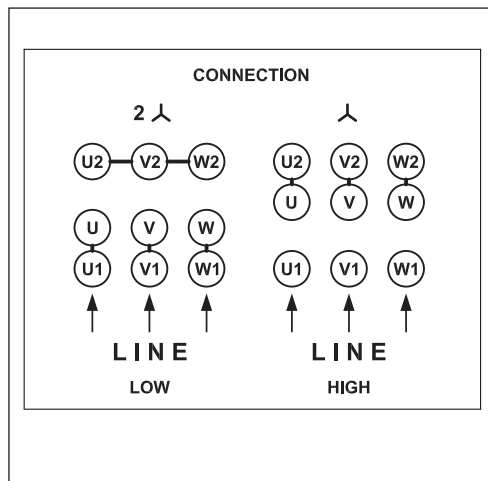
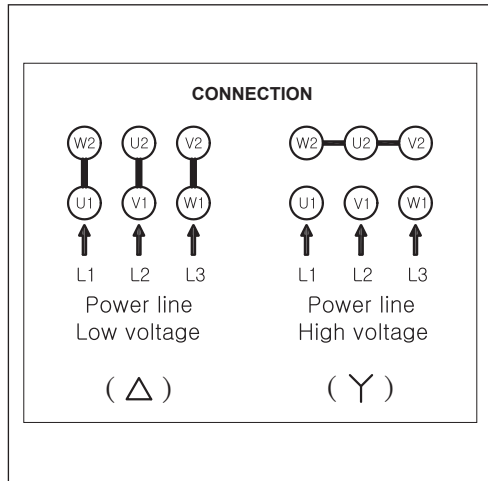

Not applicable from 25HP (Including) motors and above.



SBK/CBK Immersible pumps



在開始安裝與操作之前，請仔細研讀本說明書裡各項的安裝與操作說明。

1. 應用

- 1.1 本機型SBK,CBK產品是採用多段離心式設計之泵浦。可用來傳送工具機上之液體。
- 1.2 本泵浦不可以被使用於易燃的液體輸送，諸如柴油、石油、汽油或類似的液體。適用液體包括水溶性、低黏稠度、中性之冷却/潤滑液。

2. 型號說明

泵浦型別主要依加壓導室而來，有葉輪之加壓導室為標準加壓導室，配合無葉輪的空加壓導室組合，可應用於另外的尺寸場合，泵浦的型別編號由泵浦銘板上可查得。

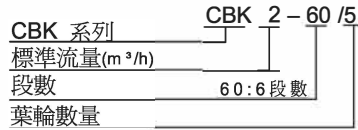
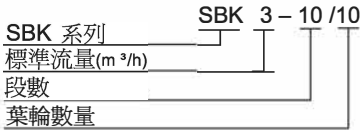

3. 使用條件

液體溫度： -10°C ~ +90°C
使用環境溫度：+50°C
防護等級： IP55
絕緣等級： F

4. 裝置



馬達表面有高熱，所以安裝位置儘量避免人容易意外碰觸到的位置。

4.1 吸入狀況

為防止泵浦於低水位時乾轉受損，其操作最低水位極限為 40mm (圖 1)

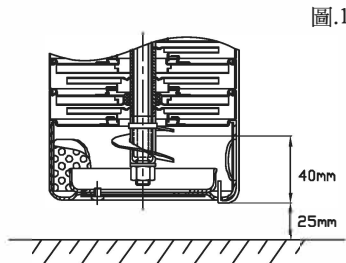



5. 電路安裝

- ⚠ 5.1 電路必須依照各地規定的標準來安裝，於安裝泵浦電路時，必須將電源關閉。
- ⚠ 5.2 會產生電的危險警告標示，於接線盒外明確標示，敬請小心。
- 5.3 泵浦使用的電壓，頻率標示於銘板上。同時請確認馬達標示的電壓、頻率與使用的電源規格相同，泵浦必須外接一個 ON/OFF 開關。
- 5.4 三相馬達必須接到啟動裝置，並檢視指示電流是否與銘板標示相符，且馬達電路連接須與接線盒蓋標示一致。
- 5.5 三相電源泵浦，必須檢查轉向，由風罩端看為順時鐘方向且於馬達風罩上有箭頭標示正確轉向，若從風罩端看為逆時鐘方向，則必須更改轉向，於更改轉向前必須先切斷電源，再將其電源線其中 2 條對調。

6. 啟動

於開始啟動泵浦前，須確認之操作的事項：

- 6.1 馬達轉向是否正確，從風罩端看，應為順時鐘方向。
- 6.2 全部的管路是否密閉，管路洩漏會造成泵浦壓力損失。
- 6.3 泵浦體需有液體存在。
- 6.4 濾網沒有被雜物堵塞。
- 6.5 初次啟動或久未使用，請先以螺絲起子在馬達軸心末端依旋轉標籤方向指示順時針方向或逆時針方向試轉，確定泵浦可自由旋轉後方可啟動馬達。

7. 操作維護

於泵浦運轉時，不被允許將管路開關關閉，若是接近 5 分鐘，泵浦將受到損害。

7.1 潤滑維護

泵浦內機械軸封與軸套皆為自潤式，由傳動液體來潤滑。

7.2 濾網

須應常保持清潔，確定無雜物堵塞，如此才能維持一個最佳的液體流量。

7.3 定期檢查

在一定的操作時間，請必須作以下的檢查：

- 7.3.1 檢查液體的流量和操作壓力。
- 7.3.2 檢查管路系統是否洩漏。
- 7.3.3 檢查馬達的起動是否正常。
- 7.3.4 檢查全部的操縱器，是否都達正常的狀況。
- 7.4 本泵浦禁止使用於具有爆炸危險之環境，且使用液體溫度超過 60°C 時需加裝防護裝置，以避免燙傷。
- 7.5 假如泵浦被用來操作有害人類健康的有毒液體或污染源的話，在非一般使用情形下故障，本公司將拒絕各項的維修服務，顧客個人造成的損害，須自行負擔。



8. 故障可能原因分析

在檢查泵浦各項故障原因前，必須確定已將電源關閉才可進行。

狀況	可能原因	排除方法
1. 當啟動時，馬達不運轉	a. 電源供應失敗	重新連結電源
	b. 保險絲被熔斷	替換保險絲
	c. 馬達啟動器超載跳脫	使馬達保護恢復正常
	d. 熱保護已經跳脫	使熱保護恢復正常
	e. 馬達啟動器接觸不良或線圈失能	更換啟動器或線圈
	f. 控制電路損壞	修理這條控制電路
	g. 馬達損壞	替換馬達
2. 啟動時馬達啟動器超載立即跳脫	a. 保險絲熔斷／無熔絲開關跳脫	替換保險絲／重新啟動無熔絲開關
	b. 馬達啟動器接觸不良	替換馬達啟動器接觸
	c. 電纜連接鬆脫或不良	替換或固定電纜連接
	d. 馬達損壞	替換馬達
	e. 泵浦堵塞	去除堵塞
	f. 過載保護裝置設定過低	正確設定啟動器過載保護電流值
3. 馬達啟動器超載偶爾跳脫	a. 過載保護裝置設定過低	正確設定啟動器過載保護電流值
	b. 尖峰用電時電壓過低	改善供電品質
4. 馬達啟動器沒跳脫而泵浦無運轉	a. 電源供應失敗	重新連結電源
	b. 保險絲被熔斷	替換保險絲
	c. 熱保護已經跳脫	使熱保護恢復正常
	d. 馬達啟動器接觸不良或線圈失能	更換啟動器或線圈
5. 泵浦正常運轉但出水量不正常	a. 泵浦濾網阻塞	清洗濾器
	b. 水箱液位過低	增加液體容量
	c. 吸入空氣	檢查抽吸條件
6. 軸封滲漏	a. 軸封損壞	替換軸封
7. 噪音	a. 吸入空氣	檢查抽吸條件
	b. 軸心位置錯誤(摩擦阻力)造成泵浦無法自由旋轉	調整泵浦軸心位置

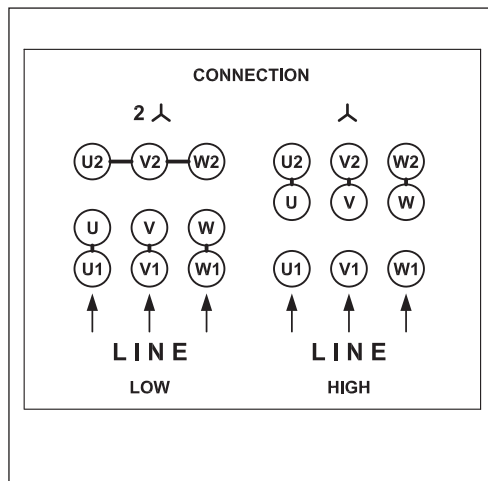
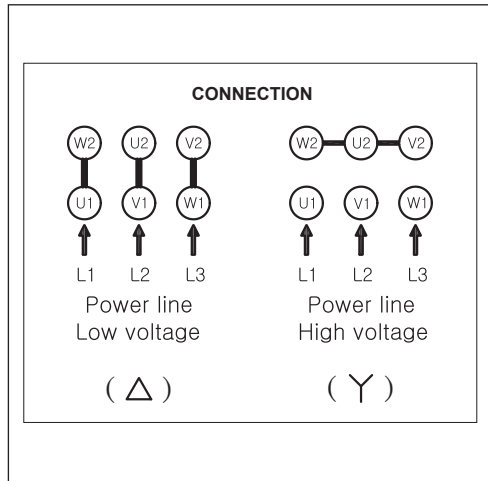

*備註:25HP(含)以上馬達不適用。

